

MOTOMAN GP35L

Handling & General Applications
with the GP-series



The MOTOMAN GP35L is a dynamic, high-speed robot featuring an extended reach for large parts. It offers superior performance in laser welding, coating, dispensing, gluing, material cutting and material handling applications.

KEY BENEFITS

- High repeatability: ± 0.07 mm
- Ideal for a variety of applications, multi-purpose robot
- Wide motion range
- Small interference radius reduces floorspace requirements
- Specifically designed for processing large parts
- Protection class IP54/67 as standard

Controlled by
YRC1000

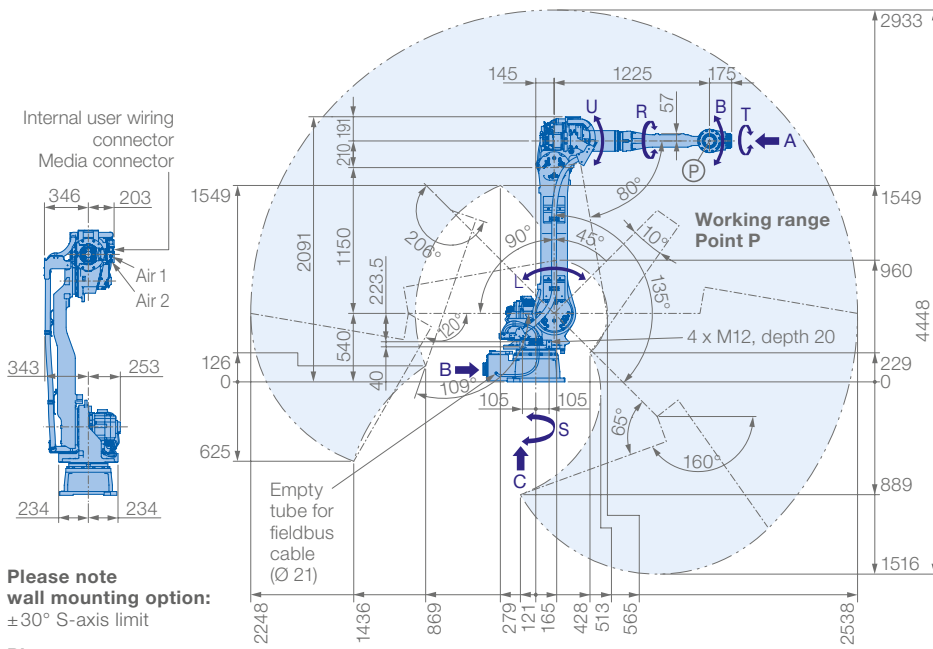

Please note wall mounting option:
±30° S-axis limit

Please note ceiling mounting option:
Please notice working range of B-axis

Please note tilted robot:
0°–90° limitation of S-axis, details on request

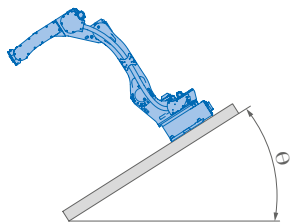

Robot installation angle θ [deg.]	S-axis operating range [deg.]
$0 \leq \theta \leq 30$	±180 (Standard)
$30 < \theta \leq 35$	±60
$35 < \theta \leq 45$	±45
$45 < \theta$	±45

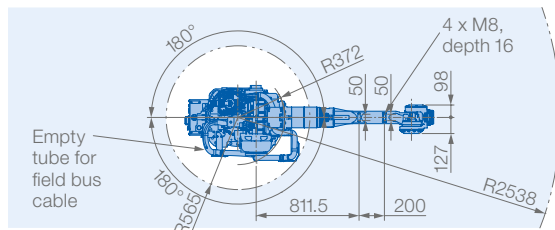

Allowable wrist load

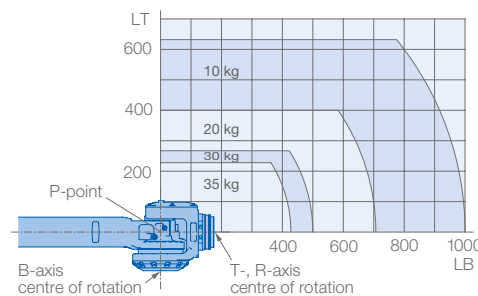

View A

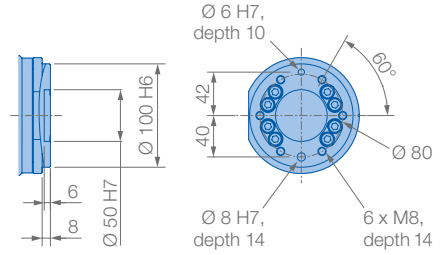

View B

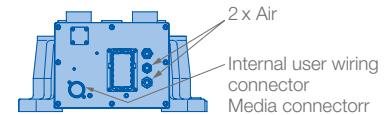

View C

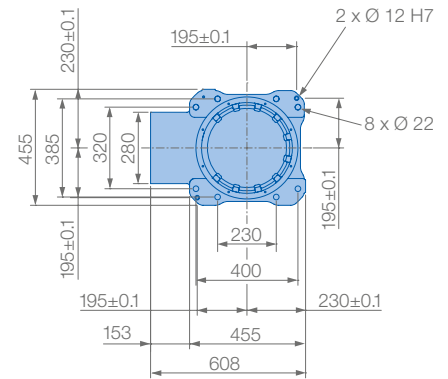

Mounting options: Floor, ceiling, wall, tilt*

Protection class: IP54/67

* tilt with condition of angle – see table left side

Wrist + U-arm in front	Up to 35 kg for attaching load mass including wrist load
U-arm behind	Up to 10 kg, 49 N · m (5 kgf · m) max. for increased moment amount of upper arm (floor-, ceiling-mounted type only)
S-axis below	Up to 30 kg (floor-, ceiling-mounted type only)

Specifications GP35L

Axes	Maximum motion range [°]	Maximum speed [°/sec.]	Allowable moment [Nm]	Allowable moment of inertia [kg · m ²]	Controlled axes	6
S	±180	180	–	–	Max. payload [kg]	35
L	+135/–90	140	–	–	Repeatability [mm]	±0.07
U	+206/–80	178	–	–	Max. working range R [mm]	2538
R	±360	250	147	10	Temperature [°C]	0 to +45
B	±125	250	147	10	Humidity [%]	20 – 80
T	±360	360	78	4	Weight [kg]	600
					Power supply, average [KVA]	4.0