

AC Servo Drives  
 **$\Sigma$ -V Series**  
**USER'S MANUAL**  
**Design and Maintenance**  
Linear Motor  
Command Option Attachable Type

SGDV SERVOPACK  
SGLGW/SGLFW/SGLTW/SGLCW/SGT Servomotors

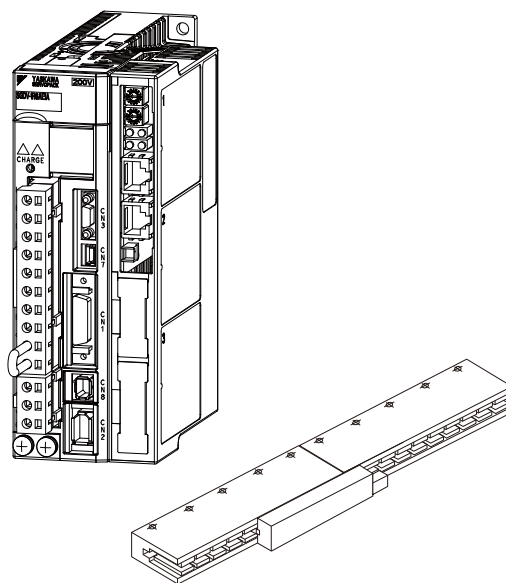

Outline	1
Panel Display and Operation of Digital Operator	2
Wiring and Connection	3
Operation	4
Adjustments	5
Utility Functions (Fn□□□)	6
Monitor Modes (Un□□□)	7
Troubleshooting	8
Appendix	9

Copyright © 2009 YASKAWA ELECTRIC CORPORATION

---

All rights reserved. No part of this publication may be reproduced, stored in a retrieval system, or transmitted, in any form, or by any means, mechanical, electronic, photocopying, recording, or otherwise, without the prior written permission of Yaskawa. No patent liability is assumed with respect to the use of the information contained herein. Moreover, because Yaskawa is constantly striving to improve its high-quality products, the information contained in this manual is subject to change without notice. Every precaution has been taken in the preparation of this manual. Nevertheless, Yaskawa assumes no responsibility for errors or omissions. Neither is any liability assumed for damages resulting from the use of the information contained in this publication.

---

## About this Manual

This manual describes informations required for designing, and maintaining  $\Sigma$ -V Series SERVOPACKs.

Be sure to refer to this manual and perform design and maintenance to select devices correctly.

Keep this manual in a location where it can be accessed for reference whenever required.

### ■ Description of Technical Terms

The following table shows the meanings of terms used in this manual.

Term	Meaning
Cursor	A mark that indicates the input position of data displayed on the digital operator
Linear servomotor	$\Sigma$ -V Series SGLGW, SGLFW, SGLTW, or SGLCW linear servomotor, SGT linear slider
SERVOPACK	$\Sigma$ -V Series SGD V SERVOPACK
Servo drive	A set including a servomotor and SERVOPACK (i.e., a servo amplifier)
Servo system	A servo control system that includes the combination of a servo drive with a host controller and peripheral devices
Servo ON	When power is being supplied to the servomotor
Servo OFF	When power is not being supplied to the servomotor
Base block (BB)	Turning OFF the power by shutting OFF the base current of the IGBT for the current amplifier
Linear scale connection cables	A set of cables including a cable for connecting serial converter unit, a cable for connecting linear scale, and a cable for connecting hall sensor

### ■ IMPORTANT Explanations

The following icon is displayed for explanations requiring special attention.



IMPORTANT

- Indicates important information that should be memorized, as well as precautions, such as alarm displays, that do not involve potential damage to equipment.

### ■ Notation Used in this Manual

#### • Reverse Symbol Notation

In this manual, the names of reverse signals (ones that are valid when low) are written with a forward slash (/) before the signal name, as shown in the following example:

Example

The notation for  $\overline{\text{BK}}$  is /BK.

#### • Parameter Notation

The following two types of notations are used for parameter digit places and settings.

### Example

Digital Operator Display

Pn000 = n . 0 0 0 0

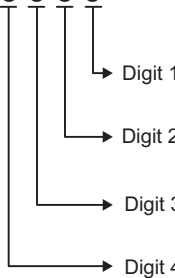

Notation Example for Pn000

Digit Notation		Set Value Notation	
Notation Method	Meaning	Notation Method	Meaning
Pn000.0	Indicates digit 1 of the parameter (Pn000).	Pn000.0 = x or n.□□□x	Indicates that digit 1 of the parameter (Pn000) is x.
Pn000.1	Indicates digit 2 of the parameter (Pn000).	Pn000.1 = x or n.□□x□	Indicates that digit 2 of the parameter (Pn000) is x.
Pn000.2	Indicates digit 3 of the parameter (Pn000).	Pn000.2 = x or n.□x□□	Indicates that digit 3 of the parameter (Pn000) is x.
Pn000.3	Indicates digit 4 of the parameter (Pn000).	Pn000.3 = x or n.x□□□	Indicates that digit 4 of the parameter (Pn000) is x.

■ **Manuals Related to the  $\Sigma$ -V Series**

Refer to the following manuals as required.

Name	Selecting Models and Peripheral Devices	Ratings and Specifications	Panels and Wiring	Trial Operation	Trial Operation and Servo Adjustment	Maintenance and Inspection
$\Sigma$ -V Series User's Manual Setup Linear Motor (SIEP S800000 44)			✓	✓		
$\Sigma$ -V Series Product Catalog (KAEP S800000 42)	✓	✓				
$\Sigma$ -V Series User's Manual Operation of Digital Operator (SIEP S800000 55)				✓	✓	✓
$\Sigma$ -V Series AC SERVOPACK SGD Safety Precautions (TOBP C710800 10)	✓		✓			✓
$\Sigma$ Series Digital Operator Safety Precautions (TOBP C730800 00)						✓
$\Sigma$ -V Series User's Manual Indexer Module (SIEP C720829 02) (Will be available soon.)		✓	✓		✓	✓
$\Sigma$ -V Series User's Manual EtherCAT (CoE) Network Module (SIEP C720829 04)		✓	✓		✓	✓
$\Sigma$ -V Series Option Module Safety Precautions (TOBP C720829 00)	✓		✓			✓
$\Sigma$ -V Series Command Option Module Installation Guide (TOBP C720829 01)	✓		✓			✓
$\Sigma$ -V Series Indexer Module Installation Guide (TOBP C720829 02)	✓		✓			✓
$\Sigma$ -V Series Feedback Option Module Installation Guide (TOBP C720829 03)	✓		✓			✓

---

## ■ Safety Information

The following conventions are used to indicate precautions in this manual. Failure to heed precautions provided in this manual can result in serious or possibly even fatal injury or damage to the products or to related equipment and systems.



Indicates precautions that, if not heeded, could possibly result in loss of life or serious injury.



Indicates precautions that, if not heeded, could result in relatively serious or minor injury, damage to the product, or faulty operation. In some situations, the precautions indicated could have serious consequences if not heeded.



Indicates prohibited actions that must not be performed. For example, this symbol would be used to indicate that fire is prohibited as follows:





Indicates compulsory actions that must be performed. For example, this symbol would be used as follows to indicate that grounding is compulsory:



## Safety Precautions

These safety precautions are very important. Read them before performing any procedures such as storage and transportation, installation, wiring, operation, maintenance and inspection, or disposal. Be sure to always observe these precautions thoroughly.

### WARNING

- If you have a pacemaker or any other electronic medical device, do not go near the magnetic way of the linear servomotor.  
Failure to observe this warning may result in the malfunction of the medical device.
- Be sure to use nonmagnetic tools when installing or working close to the linear servomotor. (Example: a beryllium-copper alloy hexagonal wrench set, made by NGK Insulators, Ltd.)
- Before starting operation with a machine connected, make sure that an emergency stop can be applied at any time.  
Failure to observe this warning may result in injury or damage to the product.
- Never touch the linear servomotor or machinery during operation.  
Failure to observe this warning may result in injury.
- Before wiring, install the SERVOPACK and the linear servomotor.  
Failure to observe this warning may result in electric shock.
- Never touch the inside of the SERVOPACKs.  
Failure to observe this warning may result in electric shock.
- Do not remove the cover of the power supply terminal while the power is ON.  
Failure to observe this warning may result in electric shock.
- After the power is turned OFF or after a voltage resistance test, do not touch terminals while the charge indicator is ON.  
Residual voltage may cause electric shock.
- Follow the procedures and instructions provided in this manual for trial operation.  
Failure to do so may result not only in faulty operation and damage to equipment, but also in personal injury.
- Do not remove the front cover, cables, connectors, or optional items from the upper front of the SERVOPACK while the power is ON.  
Failure to observe this warning may result in electric shock.
- Do not damage, press, exert excessive force on, or place heavy objects on the cables.  
Failure to observe this warning may result in electric shock, stopping operation of the product, or fire.
- Provide an appropriate braking device on the machine side to ensure safety.  
Failure to observe this warning may result in injury.
- Do not come close to the machine immediately after resetting an instantaneous power interruption. The machine may restart unexpectedly. Take appropriate measures to ensure safety against an unexpected restart.  
Failure to observe this warning may result in injury.
-  Connect the ground terminal according to local electrical codes (100 Ω or less for a SERVOPACK with a 100 V, 200 V power supply, 10 Ω or less for a SERVOPACK with a 400 V power supply).  
Improper grounding may result in electric shock or fire.
-  Installation, disassembly, or repair must be performed only by authorized personnel.  
Failure to observe this warning may result in electric shock or injury.
- The person who designs a system using the safety function (Hard Wire Base Block function) must have full knowledge of the related safety standards and full understanding of the instructions in this manual.  
Failure to observe this warning may result in injury.

## ■ Storage and Transportation



### CAUTION

- Be sure to store the magnetic way in the package that was used for delivery.
- Do not store or install the product in the following locations.  
Failure to observe this caution may result in fire, electric shock, or damage to the product.
  - Locations subject to direct sunlight
  - Locations subject to ambient operating temperatures outside the range specified in the storage/installation temperature conditions
  - Locations subject to humidity outside the range specified in the storage/installation humidity conditions
  - Locations subject to condensation as the result of extreme changes in temperature
  - Locations subject to corrosive or flammable gases
  - Locations subject to dust, salts, or iron dust
  - Locations subject to exposure to water, oil, or chemicals
  - Locations subject to shock or vibration
- Do not carry the linear servomotor by its cables.  
Failure to observe this caution may result in injury or malfunction.
- Do not place any load exceeding the limit specified on the packing box.  
Failure to observe this caution may result in injury or malfunction.
- If disinfectants or insecticides must be used to treat packing materials such as wooden frames, pallets, or plywood, the packing materials must be treated before the product is packaged, and methods other than fumigation must be used.  
Example: Heat treatment, where materials are kiln-dried to a core temperature of 56°C for 30 minutes or more.  
  
If the electronic products, which include stand-alone products and products installed in machines, are packed with fumigated wooden materials, the electrical components may be greatly damaged by the gases or fumes resulting from the fumigation process. In particular, disinfectants containing halogen, which includes chlorine, fluorine, bromine, or iodine can contribute to the erosion of the capacitors.



## ■ Installation

### CAUTION

- When unpacking and installing magnetic way, check that there is no metal fragments or magnetized objects near the magnetic way because they may be affected by the magnetic attraction of the magnetic way.  
Failure to observe this caution may result in injury or damage to the magnetic way's magnets.
- Do not use the magnetic way near metal or other magnetized objects.  
Failure to observe this caution may result in injury.
- Do not place clocks, magnetic cards, floppy disks, or measuring instruments close to the magnetic way.  
Failure to observe this caution may result in malfunction or damage to these items by the magnetic force.
- Securely mount the linear servomotor onto the machine.  
If the linear servomotor is not mounted securely, it may loosen during operation.
- Do not carry the magnetic way by its magnet protection cover.  
Failure to observe this caution may result in injury by the cover's edge or the shape of the cover may become distorted.

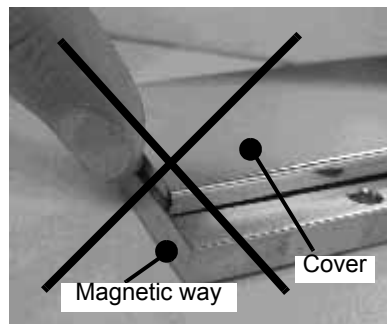

- When removing the dummy plate for reducing magnetic force used for the SGLFW magnetic way, pay attention to the magnetic attraction of the magnetic way. Do not place the removed plate close to the magnetic way.  
Failure to observe this caution may result in injury or damage to the magnetic way's magnets or the magnet protection cover.
- Install SERVOPACKs, linear servomotors, and regenerative resistors on nonflammable objects.  
Installing directly onto or near flammable objects may result in fire.
- Never use the product in an environment subject to water, corrosive gases, inflammable gases, or combustibles.  
Failure to observe this caution may result in electric shock or fire.
- Do not step on or place a heavy object on the product.  
Failure to observe this caution may result in injury or malfunction.
- Do not cover the inlet or outlet ports and prevent any foreign objects from entering the product.  
Failure to observe this caution may cause internal elements to deteriorate resulting in malfunction or fire.
- Be sure to install the product in the correct direction.  
Failure to observe this caution may result in malfunction.
- Provide the specified clearances between the SERVOPACK and the control panel or with other devices.  
Failure to observe this caution may result in fire or malfunction.
- Do not apply any strong impact.  
Failure to observe this caution may result in malfunction.

## ■ Wiring



### CAUTION

- Securely tighten the cable connector screws and securing mechanism.  
If the connector screws and securing mechanism are not secure, they may loosen during operation.
- Use cables with a radius, heat resistance, and flexibility suitable for the system.
- If the SERVOPACK malfunctions, turn OFF the main circuit's power supply of the SERVOPACK.  
The continuous flow of a large current may cause fire.
- Use a noise filter to minimize the effects of electromagnetic damage.  
Failure to observe this caution may result in electromagnetic damage to electronic devices used near the SERVOPACK.
- Do not connect a commercial power supply to the U, V, or W terminals for the linear servomotor connection.  
Failure to observe this caution may result in injury or fire.
- Securely connect the main circuit power supply terminal screws and linear servomotor connection terminal screws.  
Failure to observe this caution may result in fire.
- Do not bundle or run the main circuit cables together with the I/O signal cables or linear scale connection cables in the same duct. Keep them separated by at least 30 cm.  
Failure to do so may result in malfunction.
- Use shielded twisted-pair wires or multi-core shielded twisted-pair wires for I/O signal cables and linear scale connection cables.
- The maximum cable length is 3 m for the I/O signals, 20 m for the linear servomotor main circuit, 20 m for the serial converter unit, 15 m for the linear scale, and 15 m for the hall sensor.
- Do not touch the power supply terminals while the charge indicator is ON after turning power OFF because high voltage may still remain in the SERVOPACK.  
Make sure the charge indicator is OFF first before starting wiring and inspection.
- Observe the following precautions when wiring main circuit terminals.
  - Remove main circuit terminals from the SERVOPACK prior to wiring.
  - Insert only one main circuit cable per opening in the main circuit terminals.
  - Make sure that no part of the core wire comes into contact with (i.e., short-circuit) adjacent wires.
- Do not turn ON the power to the SERVOPACK until all wiring has been completed, including the main circuit terminals.
- Do not connect the SERVOPACK for 200 V directly to a voltage of 400 V.  
The SERVOPACK will be destroyed.
- Be sure to wire correctly and securely.  
Failure to observe this caution may result in motor overrun, injury, or malfunction.
- Always use the specified power supply voltage.  
An incorrect voltage may result in burning.
- Make sure that the polarity is correct.  
Incorrect polarity may cause ruptures or damage.
- Take appropriate measures to ensure that the input power supply is supplied within the specified voltage fluctuation range. Be particularly careful in places where the power supply is unstable.  
An incorrect power supply may result in damage to the product.
- Install external breakers or other safety devices against short-circuiting in external wiring.  
Failure to observe this caution may result in fire.
- Take appropriate and sufficient countermeasures for each form of potential interference when installing systems in the following locations.  
Failure to observe this caution may result in damage to the product.
  - Locations subject to static electricity or other forms of noise
  - Locations subject to strong electromagnetic fields and magnetic fields
  - Locations subject to possible exposure to radioactivity
  - Locations close to power supplies
- Wiring or inspection must be performed by a technical expert.
- Use a 24-VDC power supply with double insulation or reinforced insulation.

## ■ Operation

### CAUTION

- Always use the linear servomotor and SERVOPACK in one of the specified combinations.  
Failure to observe this caution may result in fire or malfunction.
- Do not stand within the machine's range of motion during operation.  
Failure to observe this caution may result in injury.
- Before operation, install a limit switch or stopper on the end of movable range to prevent unexpected movement.  
Failure to observe this caution may result in injury.
- During trial operation, confirm that the holding brake works correctly. Furthermore, secure system safety against problems such as signal line disconnection.
- Before starting operation with a machine connected, change the settings to match the parameters of the machine.  
Starting operation without matching the proper settings may cause the machine to run out of control or malfunction.
- Do not frequently turn power ON and OFF.  
Since the SERVOPACK has a capacitor in the power supply, a high charging current flows when power is turned ON. Frequently turning power ON and OFF causes main power devices like capacitors and fuses to deteriorate, resulting in unexpected problems.
- When using JOG operations (Fn002), search operations (Fn003), or EasyFFT operations (Fn206), forcing movable machine parts to stop does not work for forward overtravel or reverse overtravel. Take necessary precautions.  
Failure to observe this caution may result in damage to the product.
- When using the linear servomotor on a vertical axis, install a safety device such as a counterbalance so that the workpiece does not fall if an alarm or overtravel occurs. And, set the parameters so that the linear servomotor will stop by using a zero clamp at occurrence of overtravel.  
The workpiece may fall during overtraveling.
- When not using turning-less function, set to the correct mass ratio (Pn103).  
Setting an incorrect mass ratio may cause vibration.
- Do not touch the SERVOPACK heatsinks, regenerative resistor, or linear servomotor while power is ON or soon after the power is turned OFF.  
Failure to observe this caution may result in burns due to high temperatures.
- Do not make any extreme adjustments or setting changes of parameters.  
Failure to observe this caution may result in injury or damage to the product due to unstable operation.
- If an alarm occurs, shut down the main circuit power supply.  
Failure to observe this caution may result in fire due to regenerative resistor overheating caused by regenerative transistor failure.
- When an alarm occurs, remove the cause, reset the alarm after confirming safety, and then resume operation.  
Failure to observe this caution may result in damage to the product, fire, or injury.
- An alarm or warning may be generated if communications are executed with the host controller during operation using SigmaWin+ or the digital operator.  
If an alarm or warning is generated, the process currently being executed may be aborted and the system may stop.

## ■ Maintenance and Inspection

### CAUTION

- Do not disassemble the SERVOPACK or the linear servomotor.  
Failure to observe this caution may result in electric shock or injury.
- Do not change wiring while the power is ON.  
Failure to observe this caution may result in electric shock or injury.
- When replacing the SERVOPACK, resume operation only after copying the previous SERVOPACK parameters to the new SERVOPACK.  
Failure to observe this caution may result in damage to the product.

---

■ Disposal



**CAUTION**

- When disposing of the products, treat them as ordinary industrial waste.

■ General Precautions

**Observe the following general precautions  
to ensure safe application.**

- The products shown in illustrations in this manual are sometimes shown without covers or protective guards. Always replace the cover or protective guard as specified first, and then operate the products in accordance with the manual.
- The drawings presented in this manual are typical examples and may not match the product you received.
- If the manual must be ordered due to loss or damage, inform your nearest Yaskawa representative or one of the offices listed on the back of this manual.

---

# Warranty

## (1) Details of Warranty

### ■ Warranty Period

The warranty period for a product that was purchased (hereafter called “delivered product”) is one year from the time of delivery to the location specified by the customer or 18 months from the time of shipment from the Yaskawa factory, whichever is sooner.

### ■ Warranty Scope

Yaskawa shall replace or repair a defective product free of charge if a defect attributable to Yaskawa occurs during the warranty period above. This warranty does not cover defects caused by the delivered product reaching the end of its service life and replacement of parts that require replacement or that have a limited service life.

This warranty does not cover failures that result from any of the following causes.

1. Improper handling, abuse, or use in unsuitable conditions or in environments not described in product catalogs or manuals, or in any separately agreed-upon specifications
2. Causes not attributable to the delivered product itself
3. Modifications or repairs not performed by Yaskawa
4. Abuse of the delivered product in a manner in which it was not originally intended
5. Causes that were not foreseeable with the scientific and technological understanding at the time of shipment from Yaskawa
6. Events for which Yaskawa is not responsible, such as natural or human-made disasters

## (2) Limitations of Liability

1. Yaskawa shall in no event be responsible for any damage or loss of opportunity to the customer that arises due to failure of the delivered product.
2. Yaskawa shall not be responsible for any programs (including parameter settings) or the results of program execution of the programs provided by the user or by a third party for use with programmable Yaskawa products.
3. The information described in product catalogs or manuals is provided for the purpose of the customer purchasing the appropriate product for the intended application. The use thereof does not guarantee that there are no infringements of intellectual property rights or other proprietary rights of Yaskawa or third parties, nor does it construe a license.
4. Yaskawa shall not be responsible for any damage arising from infringements of intellectual property rights or other proprietary rights of third parties as a result of using the information described in catalogs or manuals.

---

### (3) Suitability for Use

1. It is the customer's responsibility to confirm conformity with any standards, codes, or regulations that apply if the Yaskawa product is used in combination with any other products.
2. The customer must confirm that the Yaskawa product is suitable for the systems, machines, and equipment used by the customer.
3. Consult with Yaskawa to determine whether use in the following applications is acceptable. If use in the application is acceptable, use the product with extra allowance in ratings and specifications, and provide safety measures to minimize hazards in the event of failure.
  - Outdoor use, use involving potential chemical contamination or electrical interference, or use in conditions or environments not described in product catalogs or manuals
  - Nuclear energy control systems, combustion systems, railroad systems, aviation systems, vehicle systems, medical equipment, amusement machines, and installations subject to separate industry or government regulations
  - Systems, machines, and equipment that may present a risk to life or property
  - Systems that require a high degree of reliability, such as systems that supply gas, water, or electricity, or systems that operate continuously 24 hours a day
  - Other systems that require a similar high degree of safety
4. Never use the product for an application involving serious risk to life or property without first ensuring that the system is designed to secure the required level of safety with risk warnings and redundancy, and that the Yaskawa product is properly rated and installed.
5. The circuit examples and other application examples described in product catalogs and manuals are for reference. Check the functionality and safety of the actual devices and equipment to be used before using the product.
6. Read and understand all use prohibitions and precautions, and operate the Yaskawa product correctly to prevent accidental harm to third parties.

### (4) Specifications Change

The names, specifications, appearance, and accessories of products in product catalogs and manuals may be changed at any time based on improvements and other reasons. The next editions of the revised catalogs or manuals will be published with updated code numbers. Consult with your Yaskawa representative to confirm the actual specifications before purchasing a product.

## Applicable Standards

### ■ North American Safety Standards (UL)

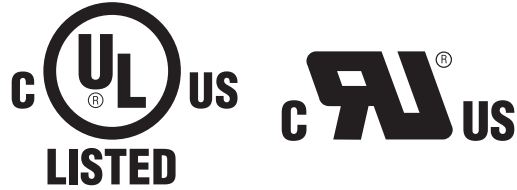

	Model	UL* Standards (UL File No.)
SERVOPACK	• SGD V	UL508C (E147823)

\* Underwriters Laboratories Inc.

### ■ European Standards



	Model	Low Voltage Directive	EMC Directive		Safety Standards
			EMI	EMS	
SERVOPACK	• SGD V	EN50178 EN61800-5-1	EN55011/A2 group 1 class A EN61800-3	EN61800-3 EN61000-6-2	EN954-1 IEC61508-1 to 4

Note: Because SERVOPACKS and linear servomotors are built into machines, certification is required after installation in the final product.

---

# Contents

About this Manual .....	iii
Safety Precautions .....	vii
Warranty .....	xiii
Applicable Standards .....	xv
<b>Chapter 1 Outline .....</b>	<b>1-1</b>
1.1 $\Sigma$ -V Series SERVOPACKs .....	1-2
1.2 Part Names .....	1-2
1.3 SERVOPACK Ratings and Specifications .....	1-3
1.3.1 Ratings .....	1-3
1.3.2 Basic Specifications .....	1-5
1.4 SERVOPACK Internal Block Diagrams .....	1-8
1.4.1 Single-phase 100-V, SGD V-R70FE5A, -R90FE5A, -2R1FE5A Models .....	1-8
1.4.2 Single-phase 100-V, SGD V-2R8FE5A Model .....	1-8
1.4.3 Single-phase 200-V, SGD V-120AE5A008000 Model .....	1-9
1.4.4 Three-phase 200-V, SGD V-R70AE5A, -R90AE5A, -1R6AE5A Models .....	1-9
1.4.5 Three-phase 200-V, SGD V-2R8AE5A Model .....	1-10
1.4.6 Three-phase 200-V, SGD V-3R8AE5A, -5R5AE5A, -7R6AE5A Models .....	1-10
1.4.7 Three-phase 200-V, SGD V-120AE5A Model .....	1-11
1.4.8 Three-phase 200-V, SGD V-180AE5A, -200AE5A Models .....	1-11
1.4.9 Three-phase 200-V, SGD V-330AE5A Model .....	1-12
1.4.10 Three-phase 200-V, SGD V-550AE5A Model .....	1-12
1.4.11 Three-phase 400-V, SGD V-1R9DE5A, -3R5DE5A, -5R4DE5A Models .....	1-13
1.4.12 Three-phase 400-V, SGD V-8R4DE5A, -120DE5A Models .....	1-13
1.4.13 Three-phase 400-V, SGD V-170DE5A Model .....	1-14
1.4.14 Three-phase 400-V, SGD V-260DE5A Model .....	1-14
1.5 Examples of Servo System Configurations .....	1-15
1.5.1 Connecting to SGD V-□□□FE5A SERVOPACK .....	1-15
1.5.2 Connecting to SGD V-□□□AE5A SERVOPACK .....	1-16
1.5.3 Connecting to SGD V-□□□DE5A SERVOPACK .....	1-18
1.6 SERVOPACK Model Designation .....	1-19
1.7 Inspection and Maintenance .....	1-20
<b>Chapter 2 Panel Display and Operation of Digital Operator .....</b>	<b>2-1</b>
2.1 Panel Display .....	2-2
2.1.1 Status Display .....	2-2
2.1.2 Alarm and Warning Display .....	2-2
2.1.3 Hard Wire Base Block Display .....	2-2
2.1.4 Displays during Overtravel .....	2-2
2.2 Utility Function Mode (Fn□□□) .....	2-3
2.3 Parameter (Pn□□□) Operation .....	2-4
2.3.1 Parameter Classifications .....	2-4
2.3.2 Parameter Notation .....	2-4
2.3.3 Parameter Setting Methods .....	2-5
2.4 Monitor Mode (Un□□□) .....	2-7



<b>Chapter 3 Wiring and Connection</b> . . . . .	<b>3-1</b>
3.1 Main Circuit Wiring . . . . .	3-2
3.1.1 Main Circuit Terminals . . . . .	3-2
3.1.2 Using a Standard Power Supply Input (Single-phase 100-V, Three-phase 200-V, or Three-phase 400-V). . . . .	3-3
3.1.3 General Precautions for Wiring . . . . .	3-11
3.1.4 Using the SERVOPACK with Single-phase, 200-V Power Input . . . . .	3-12
3.1.5 Using the SERVOPACK with a DC Power Input . . . . .	3-15
3.1.6 Using More Than One SERVOPACK. . . . .	3-17
3.2 I/O Signal Connections . . . . .	3-18
3.2.1 I/O Signal (CN1) Names and Functions. . . . .	3-18
3.2.2 Safety Function Signal (CN8) Names and Functions. . . . .	3-19
3.2.3 Example of I/O Signal Connections . . . . .	3-20
3.3 I/O Signal Allocations. . . . .	3-21
3.3.1 Input Signal Allocations . . . . .	3-21
3.3.2 Output Signal Allocation. . . . .	3-23
3.4 Connection to Host Controller . . . . .	3-24
3.4.1 Sequence Input Circuits . . . . .	3-24
3.4.2 Sequence Output Circuits . . . . .	3-26
3.5 Wiring Communications Using Command Option Modules . . . . .	3-28
3.6 Linear Scale Connections . . . . .	3-29
3.6.1 Linear Scale Signal (CN2) Names and Functions . . . . .	3-29
3.6.2 Connection Example of a Linear Scale . . . . .	3-29
3.6.3 Serial Converter Unit Specifications . . . . .	3-31
3.7 Regenerative Resistors Connections. . . . .	3-33
3.7.1 Connecting Regenerative Resistors. . . . .	3-33
3.7.2 Setting Regenerative Resistor Capacity. . . . .	3-35
3.8 Noise Control and Measures for Harmonic Suppression. . . . .	3-36
3.8.1 Wiring for Noise Control. . . . .	3-36
3.8.2 Precautions on Connecting Noise Filter. . . . .	3-38
3.8.3 Connecting AC/DC Reactor for Harmonic Suppression. . . . .	3-40

<b>Chapter 4 Operation</b> . . . . .	<b>4-1</b>
4.1 Option Module Function Settings. . . . .	4-3
4.1.1 Setting Switches S1 and S2 for Option Module Functions. . . . .	4-3
4.2 Settings for Common Basic Functions. . . . .	4-4
4.2.1 Inspection and Checking before Operation . . . . .	4-4
4.2.2 Linear Servomotor Movement Direction. . . . .	4-5
4.2.3 Overtravel. . . . .	4-6
4.2.4 Electronic Gear . . . . .	4-9
4.2.5 Encoder Output Pulse . . . . .	4-12
4.2.6 Encoder Output Pulse Setting . . . . .	4-14
4.2.7 Holding Brakes. . . . .	4-15
4.2.8 Stopping Linear Servomotor after Receiving Servo OFF Command or Alarm Occurrence . . . . .	4-19
4.2.9 Instantaneous Power Interruption Settings . . . . .	4-21
4.2.10 Motor Maximum Speed . . . . .	4-21
4.2.11 SEMI-F47 Function (Force Limit Function for Low Power Supply Voltage for Main Circuit) . . . . .	4-22
4.2.12 Setting Motor Overload Detection Level . . . . .	4-25
4.3 Test Without Motor Function . . . . .	4-27
4.3.1 Related Parameters . . . . .	4-27
4.3.2 Limitations . . . . .	4-28
4.3.3 Digital Operator Display during Testing without Motor . . . . .	4-29

4.4	Limiting Force	4-30
4.4.1	Internal Force Limit	4-30
4.4.2	External Force Limit	4-31
4.4.3	Checking Output Force Limiting during Operation	4-32
4.5	Setting Absolute Linear Scale	4-33
4.5.1	Setup Procedure	4-33
4.5.2	Origin Setting (Fn020)	4-34
4.5.3	Polarity Detection (Fn080)	4-35
4.5.4	Absolute Linear Scale Reception Sequence	4-36
4.6	Other Output Signals	4-39
4.6.1	Servo Alarm Output Signal (ALM)	4-39
4.6.2	Warning Output Signal (/WARN)	4-39
4.6.3	Movement Detection Output Signal (/TGON)	4-40
4.6.4	Servo Ready Output Signal (/S-RDY)	4-40
4.7	Safety Function	4-41
4.7.1	Hard Wire Base Block (HWBB) Function	4-41
4.7.2	External Device Monitor (EDM1)	4-46
4.7.3	Application Example of Safety Functions	4-48
4.7.4	Confirming Safety Functions	4-49
4.7.5	Connecting a Safety Device	4-50
4.7.6	Precautions for Safety Functions	4-51
<b>Chapter 5 Adjustments</b>		<b>5-1</b>
5.1	Adjustments and Basic Adjustment Procedure	5-3
5.1.1	Adjustments	5-3
5.1.2	Basic Adjustment Procedure	5-4
5.1.3	Monitoring Analog Signals	5-5
5.1.4	Safety Precautions on Adjustment of Servo Gains	5-8
5.2	Tuning-less Function	5-10
5.2.1	Tuning-less Function	5-10
5.2.2	Tuning-less Levels Setting (Fn200) Procedure	5-13
5.3	Advanced Autotuning (Fn201)	5-16
5.3.1	Advanced Autotuning	5-16
5.3.2	Advanced Autotuning Procedure	5-19
5.3.3	Related Parameters	5-24
5.4	Advanced Autotuning by Reference (Fn202)	5-25
5.4.1	Advanced Autotuning by Reference	5-25
5.4.2	Advanced Autotuning by Reference Procedure	5-27
5.4.3	Related Parameters	5-31
5.5	One-parameter Tuning (Fn203)	5-32
5.5.1	One-parameter Tuning	5-32
5.5.2	One-parameter Tuning Procedure	5-33
5.5.3	One-parameter Tuning Example	5-39
5.5.4	Related Parameters	5-40
5.6	Anti-resonance Control Adjustment Function (Fn204)	5-41
5.6.1	Anti-resonance Control Adjustment Function	5-41
5.6.2	Anti-resonance Control Adjustment Function Operating Procedure	5-42
5.6.3	Related Parameters	5-46
5.7	Vibration Suppression Function (Fn205)	5-47
5.7.1	Vibration Suppression Function	5-47
5.7.2	Vibration Suppression Function Operating Procedure	5-48
5.7.3	Related Parameters	5-51
5.8	Additional Adjustment Function	5-52
5.8.1	Switching Gain Settings	5-52
5.8.2	Friction Compensation	5-57
5.8.3	Current Control Mode Selection	5-59
5.8.4	Current Gain Level Setting	5-59
5.8.5	Speed Detection Method Selection	5-59

5.9 Compatible Adjustment Function . . . . .	5-60
5.9.1 Feedforward Reference . . . . .	5-60
5.9.2 Using the Mode Switch (P/PI Switching) . . . . .	5-60
5.9.3 Force Reference Filter . . . . .	5-65
5.9.4 Position Integral Time Constant . . . . .	5-67

## Chapter 6 Utility Functions (Fn□□□) . . . . . 6-1

6.1 List of Utility Functions . . . . .	6-2
6.2 Alarm History Display (Fn000) . . . . .	6-3
6.3 JOG Operation (Fn002) . . . . .	6-4
6.4 Origin Search (Fn003) . . . . .	6-6
6.5 Program JOG Operation (Fn004) . . . . .	6-8
6.6 Initializing Parameter Settings (Fn005) . . . . .	6-14
6.7 Clearing Alarm History (Fn006) . . . . .	6-15
6.8 Offset Adjustment of Analog Monitor Output (Fn00C) . . . . .	6-16
6.9 Gain Adjustment of Analog Monitor Output (Fn00D) . . . . .	6-18
6.10 Automatic Offset-Signal Adjustment of the Motor Current Detection (Fn00E) . . . . .	6-20
6.11 Manual Offset-Signal Adjustment of the Motor Current Detection (Fn00F) . . . . .	6-21
6.12 Write Prohibited Setting (Fn010) . . . . .	6-22
6.13 Servomotor Model Display (Fn011) . . . . .	6-24
6.14 Software Version Display (Fn012) . . . . .	6-25
6.15 Resetting Configuration Error of Option Module (Fn014) . . . . .	6-26
6.16 Vibration Detection Level Initialization (Fn01B) . . . . .	6-27
6.17 Display of SERVOPACK and Servomotor ID (Fn01E) . . . . .	6-29
6.18 Software Reset (Fn030) . . . . .	6-30
6.19 EasyFFT (Fn206) . . . . .	6-31
6.20 Online Vibration Monitor (Fn207) . . . . .	6-36

## Chapter 7 Monitor Modes (Un□□□) . . . . . 7-1

7.1 List of Monitor Modes . . . . .	7-2
7.2 Monitor Displays . . . . .	7-3

## Chapter 8 Troubleshooting . . . . . 8-1

8.1 Troubleshooting . . . . .	8-2
8.1.1 List of Alarms . . . . .	8-2
8.1.2 Troubleshooting of Alarms . . . . .	8-6
8.2 Warning Displays . . . . .	8-23
8.2.1 List of Warnings . . . . .	8-23
8.2.2 Troubleshooting of Warnings . . . . .	8-25
8.3 Troubleshooting Malfunction Based on Operation and Conditions of the Linear Servomotor . . . . .	8-29

---

Chapter 9 Appendix. . . . .	9-1
9.1 List of Parameters . . . . .	9-2
9.1.1 Utility Functions . . . . .	9-2
9.1.2 Parameters. . . . .	9-3
9.2 Monitor Modes . . . . .	9-23
9.3 Parameter Recording Table . . . . .	9-24

Index. . . . .	Index-1
----------------	---------

Revision History

## Outline

1.1 $\Sigma$ -V Series SERVOPACKs .....	1-2
1.2 Part Names .....	1-2
1.3 SERVOPACK Ratings and Specifications .....	1-3
1.3.1 Ratings .....	1-3
1.3.2 Basic Specifications .....	1-5
1.4 SERVOPACK Internal Block Diagrams .....	1-8
1.4.1 Single-phase 100-V, SGD V-R70FE5A, -R90FE5A, -2R1FE5A Models .....	1-8
1.4.2 Single-phase 100-V, SGD V-2R8FE5A Model .....	1-8
1.4.3 Single-phase 200-V, SGD V-120AE5A008000 Model .....	1-9
1.4.4 Three-phase 200-V, SGD V-R70AE5A, -R90AE5A, -1R6AE5A Models .....	1-9
1.4.5 Three-phase 200-V, SGD V-2R8AE5A Model .....	1-10
1.4.6 Three-phase 200-V, SGD V-3R8AE5A, -5R5AE5A, -7R6AE5A Models .....	1-10
1.4.7 Three-phase 200-V, SGD V-120AE5A Model .....	1-11
1.4.8 Three-phase 200-V, SGD V-180AE5A, -200AE5A Models .....	1-11
1.4.9 Three-phase 200-V, SGD V-330AE5A Model .....	1-12
1.4.10 Three-phase 200-V, SGD V-550AE5A Model .....	1-12
1.4.11 Three-phase 400-V, SGD V-1R9DE5A, -3R5DE5A, -5R4DE5A Models .....	1-13
1.4.12 Three-phase 400-V, SGD V-8R4DE5A, -120DE5A Models .....	1-13
1.4.13 Three-phase 400-V, SGD V-170DE5A Model .....	1-14
1.4.14 Three-phase 400-V, SGD V-260DE5A Model .....	1-14
1.5 Examples of Servo System Configurations .....	1-15
1.5.1 Connecting to SGD V-□□□FE5A SERVOPACK .....	1-15
1.5.2 Connecting to SGD V-□□□AE5A SERVOPACK .....	1-16
1.5.3 Connecting to SGD V-□□□DE5A SERVOPACK .....	1-18
1.6 SERVOPACK Model Designation .....	1-19
1.7 Inspection and Maintenance .....	1-20

## 1.1 Σ-V Series SERVOPACKs

The Σ-V Series SERVOPACKs are designed for applications that require frequent high-speed, high-precision positioning. The SERVOPACK makes the most of machine performance in the shortest time possible, thus contributing to improving productivity.

## 1.2 Part Names

This section gives the part names of the SGD-V SERVOPACK (command option attachable type).

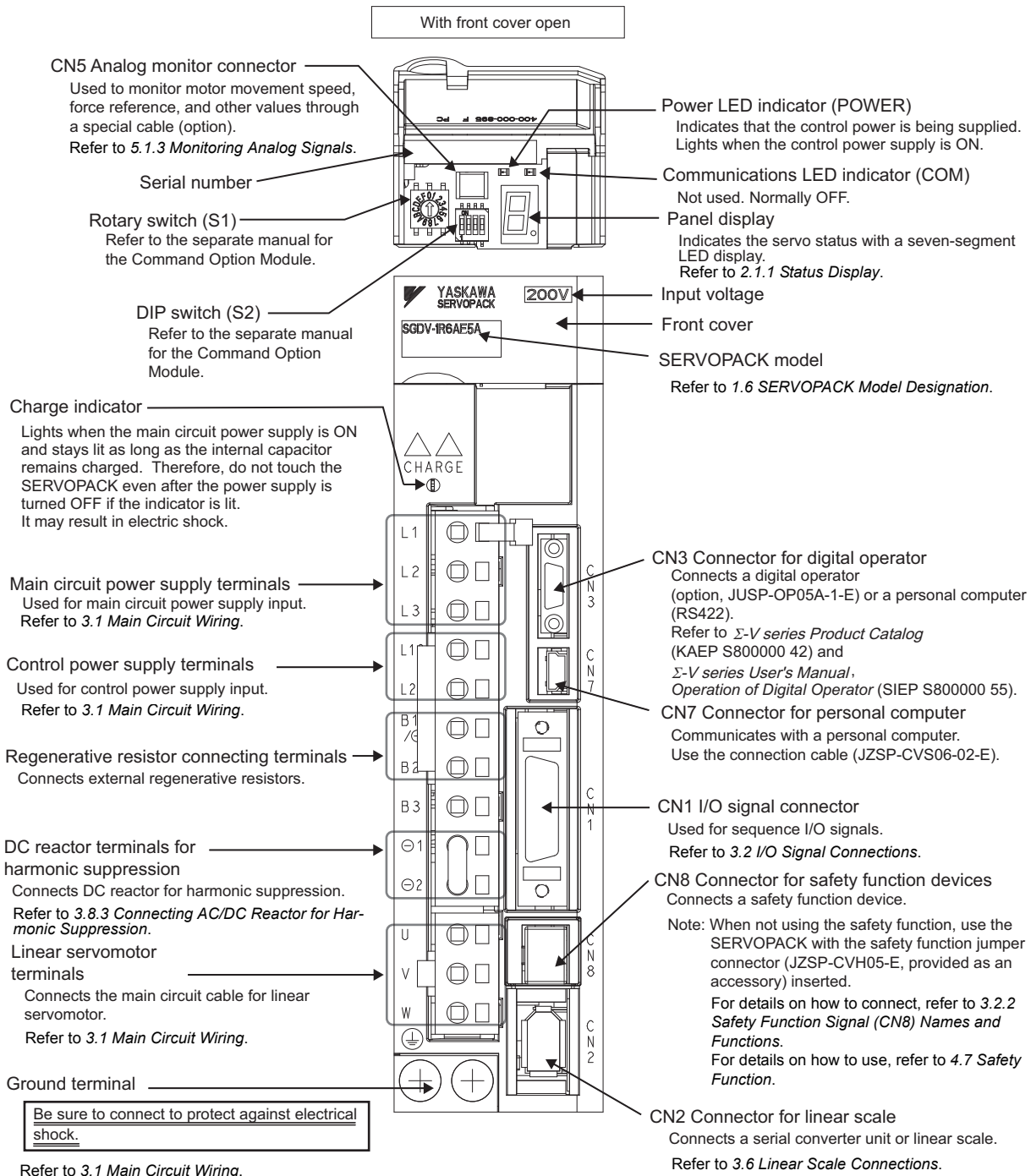

## 1.3 SERVOPACK Ratings and Specifications

This section describes the ratings and specifications of SERVOPACKs.

### 1.3.1 Ratings

Ratings of SERVOPACKs are as shown below.

#### (1) SGDV Single-phase 100-V Ratings

SGDV (Single-phase, 100 V)	R70	R90	2R1	2R8
Continuous Output Current [Arms]	0.66	0.91	2.1	2.8
Max. Output Current [Arms]	2.1	2.9	6.5	9.3
Regenerative Resistor*	None/External			
Main Circuit Power Supply	Single-phase, 100 to 115 VAC $\begin{smallmatrix} +10\% \\ -15\% \end{smallmatrix}$ , 50/60 Hz			
Control Power	Single-phase, 100 to 115 VAC $\begin{smallmatrix} +10\% \\ -15\% \end{smallmatrix}$ , 50/60 Hz			
Overvoltage Category	III			

\* Refer to 3.7 *Regenerative Resistors Connections* for details.

#### (2) SGDV Single-phase 200-V Ratings

SGDV (Single-phase, 200 V)	120* <sup>1</sup>
Continuous Output Current [Arms]	11.6
Max. Output Current [Arms]	28
Regenerative Resistor* <sup>2</sup>	Built-in/External
Main Circuit Power Supply	Single-phase, 220 to 230 VAC $\begin{smallmatrix} +10\% \\ -15\% \end{smallmatrix}$ , 50/60 Hz
Control Power	Single-phase, 220 to 230 VAC $\begin{smallmatrix} +10\% \\ -15\% \end{smallmatrix}$ , 50/60 Hz
Overvoltage Category	III

\*1. The official model number is SGDV-120AE5A008000.

\*2. Refer to 3.7 *Regenerative Resistors Connections* for details.

#### (3) SGDV Three-phase 200-V Ratings

SGDV (Three-phase, 200 V)	R70	R90	1R6	2R8	3R8	5R5	7R6	120	180	200	330	550
Continuous Output Current [Arms]	0.66	0.91	1.6	2.8	3.8	5.5	7.6	11.6	18.5	19.6	32.9	54.7
Max. Output Current [Arms]	2.1	2.9	5.8	9.3	11.0	16.9	17	28	42	56	84	130
Regenerative Resistor*	None/External						Built-in/External					External
Main Circuit Power Supply	Three-phase, 200 to 230 VAC $\begin{smallmatrix} +10\% \\ -15\% \end{smallmatrix}$ , 50/60 Hz											
Control Power	Single-phase, 200 to 230 VAC $\begin{smallmatrix} +10\% \\ -15\% \end{smallmatrix}$ , 50/60 Hz											
Overvoltage Category	III											

\* Refer to 3.7 *Regenerative Resistors Connections* for details.

## (4) SGD V Three-phase 400-V Ratings

SGDV (Three-phase, 400 V)	1R9	3R5	5R4	8R4	120	170	260
Continuous Output Current [Arms]	1.9	3.5	5.4	8.4	11.9	16.5	25.7
Max. Output Current [Arms]	5.5	8.5	14	20	28	42	65
Regenerative Resistor*	Built-in/External						External
Main Circuit Power Supply	Three-phase, 380 to 480 VAC $^{+10\%}_{-15\%}$ 50/60 Hz						
Control Power	24 VDC $\pm 15\%$						
Overvoltage Category	III						

\* Refer to 3.7 *Regenerative Resistors Connections* for details.



### 1.3.2 Basic Specifications

Basic specifications of SERVOPACKs are shown below.

Control Method		IGBT-PWM (sine-wave driven)	
Feedback		<ul style="list-style-type: none"> <li>Absolute linear scale Signal resolution <sup>*1</sup>= Sine-wave pitch of absolute linear scale /Number of divisions in absolute linear scale</li> <li>Incremental linear scale Signal resolution <sup>*2</sup>= Sine-wave pitch of incremental linear scale /Number of divisions of serial converter unit</li> </ul>	
Operating Conditions	Surrounding Air/Storage Temperature		0 to +55°C/ -20 to +85°C
	Ambient/Storage Humidity		90% RH or less (with no condensation)
	Vibration/Shock Resistance		4.9 m/s <sup>2</sup> / 19.6 m/s <sup>2</sup>
	Protection Class/ Pollution Degree		Protection class: IP10, Pollution degree: 2 An environment that satisfies the following conditions. <ul style="list-style-type: none"> <li>Free of corrosive or explosive gases</li> <li>Free of exposure to water, oil or chemicals</li> <li>Free of dust, salts or iron dust</li> </ul>
	Altitude		1000 m or less
	Others		Free of static electricity, strong electromagnetic fields, magnetic fields or exposure to radioactivity
Applicable Standards			UL508C EN50178, EN55011/A2 group 1 class A, EN61000-6-2, EN61800-3, EN61800-5-1, EN954-1, IEC61508-1 to 4
Configuration			Base-mounted <sup>*3</sup>
Performance	Speed Control Range		1:5000
	Speed Regulation <sup>*4</sup>	Load Fluctuation	0 to 100% load: ±0.01% max. (at rated speed)
		Voltage Fluctuation	Rated voltage ±10%: 0% (at rated speed)
		Temperature Fluctuation	25 ± 25 °C: ±0.1% max. (at rated speed)
	Force Control Tolerance (Repeatability)		±1%

I/O Signals	Encoder Output Pulses		Phase-A, -B, -C: line driver Encoder output pulse: any setting ratio		
	Sequence Input	Input Signals which can be allocated	Number of Channels	7 channels	
			Functions	The signal allocation and positive/negative logic can be modified. Forward run prohibited (P-OT), reverse run prohibited (N-OT), forward force limit (/P-CL), reverse force limit (/N-CL), general-purpose input signal (/SI0 to /SI6)*5	
	Sequence Output	Fixed Output	Servo alarm (ALM)		
		Output Signals which can be allocated	Number of Channels	3 channels	
	Functions		The signal allocation and positive/negative logic can be modified. Positioning completion (/COIN), speed coincidence detection (/V-CMP), linear servomotor movement detection (/TGON), servo ready (/S-RDY), force limit detection (/CLT), speed limit detection (/VLT), brake (/BK), warning (/WARN), near (/NEAR)		
Communi- cations Function	RS422A Communi- cations (CN3)	Interface	Digital operator (JUSP-OP05A-1-E), personal computer (can be connected with SigmaWin+), etc.		
		1:N Communi- cations	N = Up to 15 stations possible at RS422A		
		Axis Address Setting	Set by parameter		
	USB Communi- cations (CN7)	Interface	Personal computer (can be connected with SigmaWin+.)		
Communi- cations Standard		Complies with standard USB1.1. (12 Mbps)			
LED Display		Panel display (seven-segment, 1 digit), CHARGE and POWER indicators			
Analog Monitor (CN5)		Number of points: 2 Output voltage: $\pm 10V$ DC (linearity effective range $\pm 8V$ ) Resolution: 16 bit Accuracy: $\pm 20$ mV (Typ) Max. output current: $\pm 10$ mA Settling time ( $\pm 1\%$ ): 1.2 ms (Typ)			
Dynamic Brake (DB)		Activated when a servo alarm, overtravel (OT), or hard wire base block occurs or when the power supply for the main circuit or servomotor is turned OFF.			
Regenerative Processing		Built-in or external regenerative resistor (option)			
Overtravel Prevention (OT)		Stop by dynamic brake, deceleration to a stop, or coast to a stop when a P-OT or an N-OT signal is input			
Protection Function		Overcurrent, overvoltage, insufficient voltage, overload, regeneration error, and so on.			
Utility Function		Gain adjustment, alarm history, JOG operation, origin search, and so on.			
Safety Function	Input	/HWBB1, /HWBB2: Base Block signal for power module			
	Output	EDM1: Monitoring status of internal safety circuit (fixed output)			
Option Modules		Fully-closed Module and Command Option Module			

- \*1. Signal resolution differs in accordance with the absolute linear scale.
- \*2. Signal resolution differs in accordance with the serial converter unit. For more information, refer to *Σ-V Series Product Catalog* (KAEP S800000 42.)
- \*3. Rack mounting and duct-ventilated type available as an option.
- \*4. Speed regulation by load fluctuation is defined as follows:

$$\text{Speed regulation} = \frac{\text{No-load motor speed} - \text{Total load motor speed}}{\text{Rated motor speed}} \times 100\%$$

- \*5. For information on the functions, refer to the manual of the connected Command Option Module.

## 1.4 SERVOPACK Internal Block Diagrams

### 1.4.1 Single-phase 100-V, SGD V-R70FE5A, -R90FE5A, -2R1FE5A Models

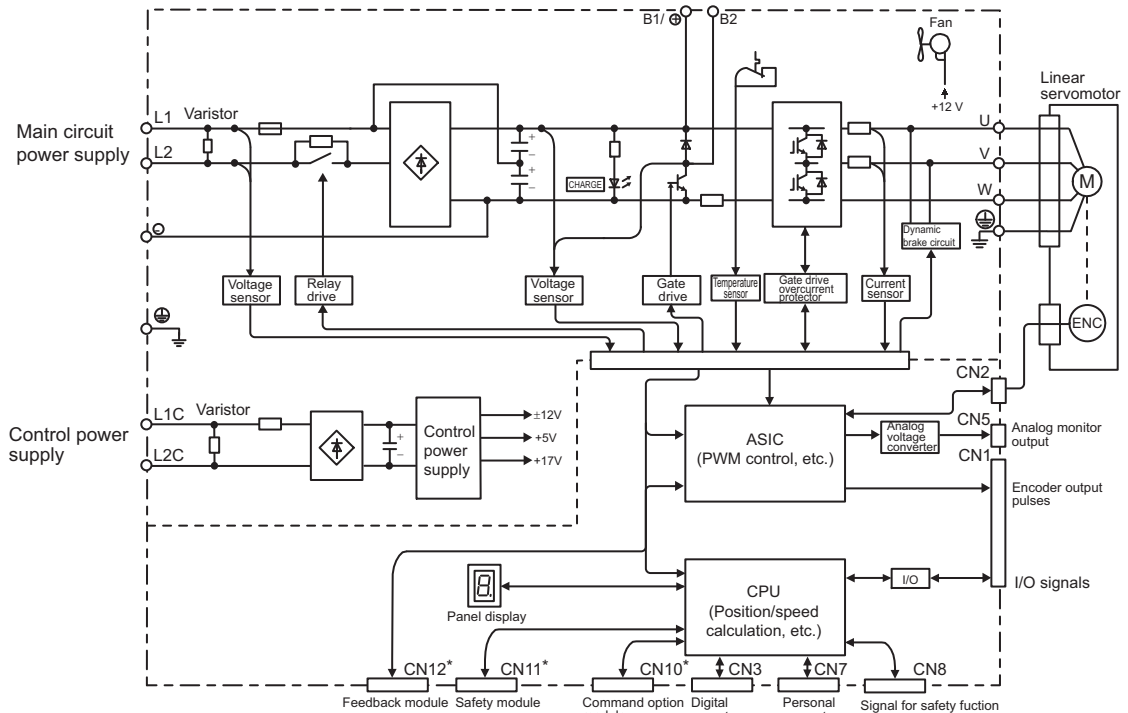

\* This external input signal is used by the option module.  
For details, refer to the manual of the connected option module.

### 1.4.2 Single-phase 100-V, SGD V-2R8FE5A Model

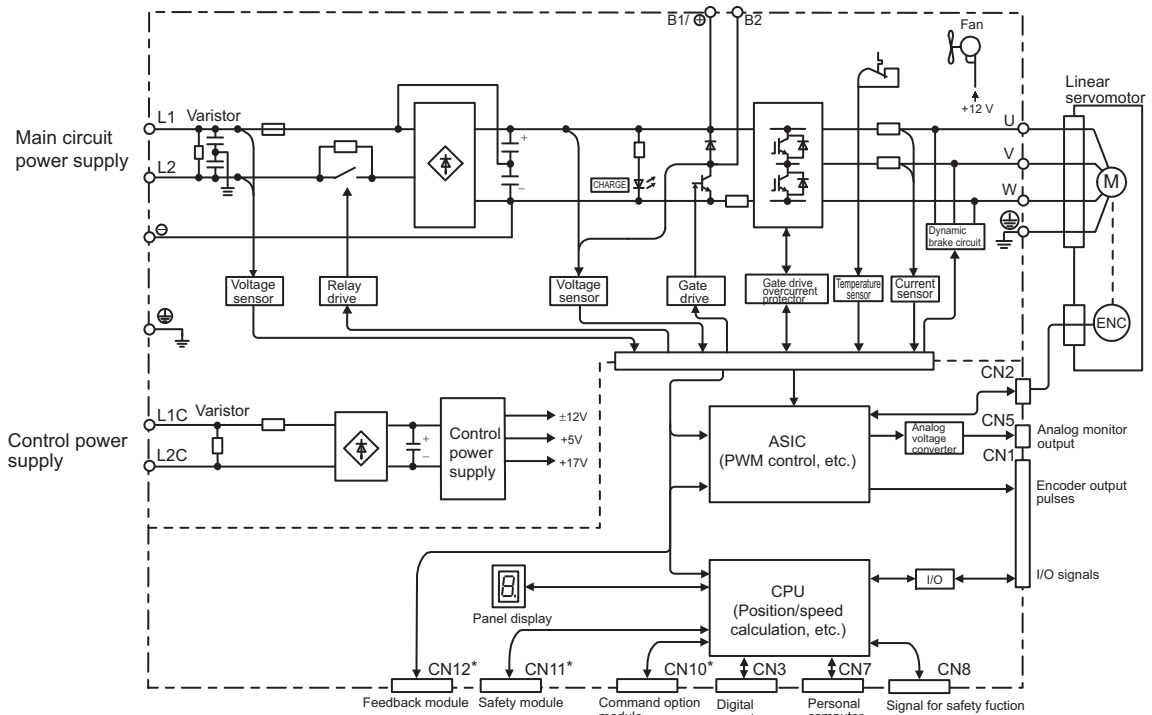

\* This external input signal is used by the option module.  
For details, refer to the manual of the connected option module.

### 1.4.3 Single-phase 200-V, SGDV-120AE5A008000 Model

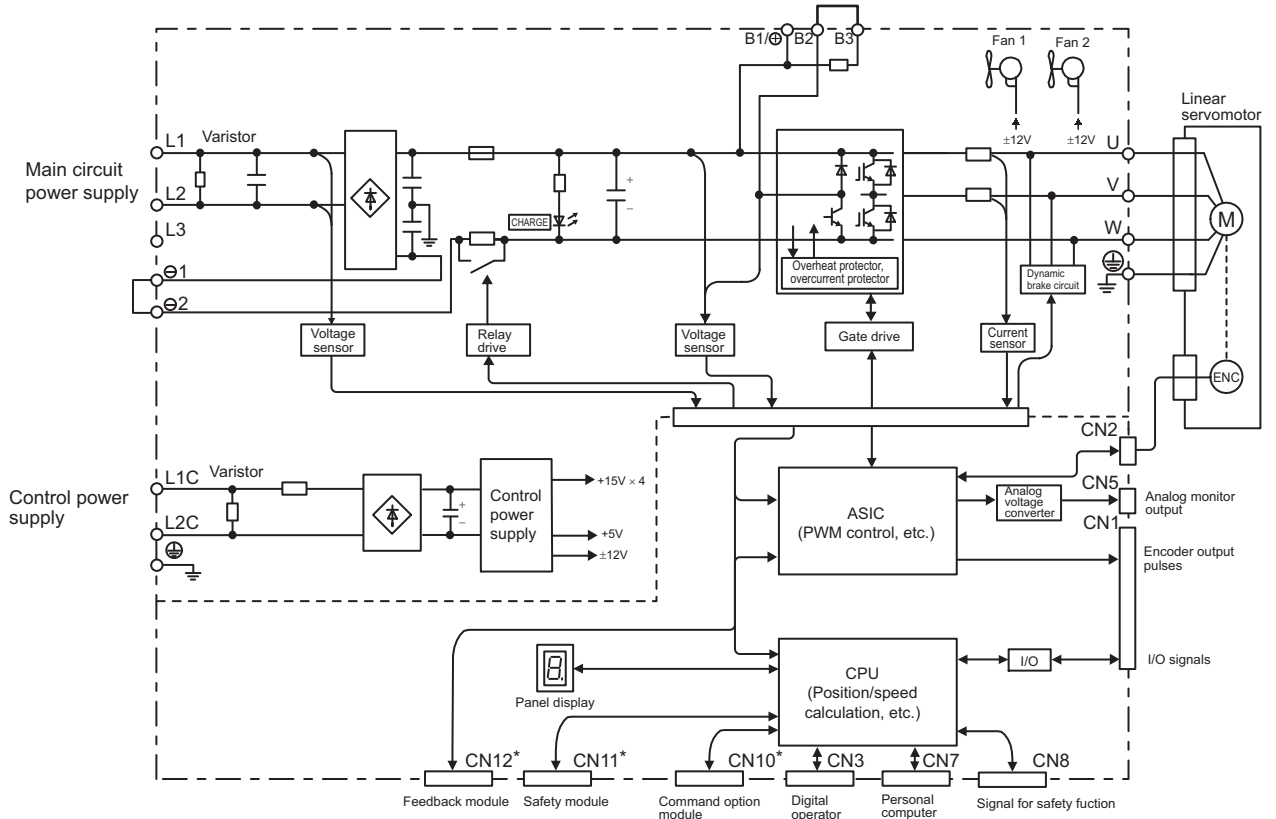

\* This external input signal is used by the option module.  
For details, refer to the manual of the connected option module.

### 1.4.4 Three-phase 200-V, SGDV-R70AE5A, -R90AE5A, -1R6AE5A Models

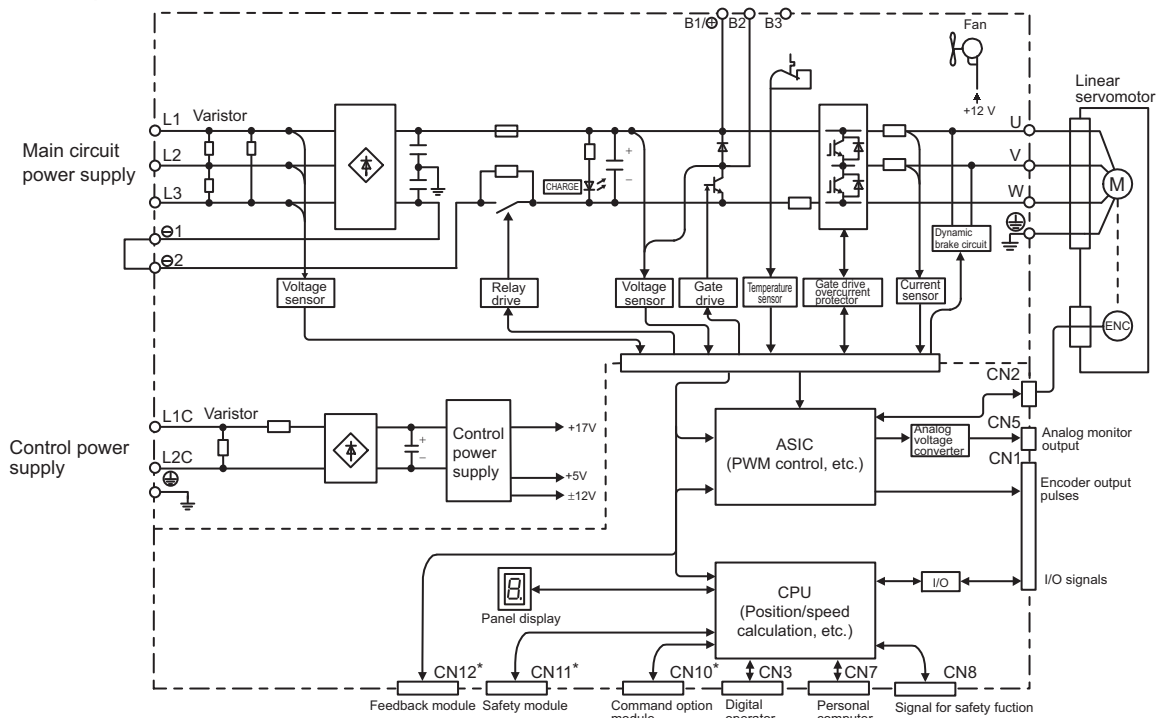

\* This external input signal is used by the option module.  
For details, refer to the manual of the connected option module.

### 1.4.5 Three-phase 200-V, SGDV-2R8AE5A Model

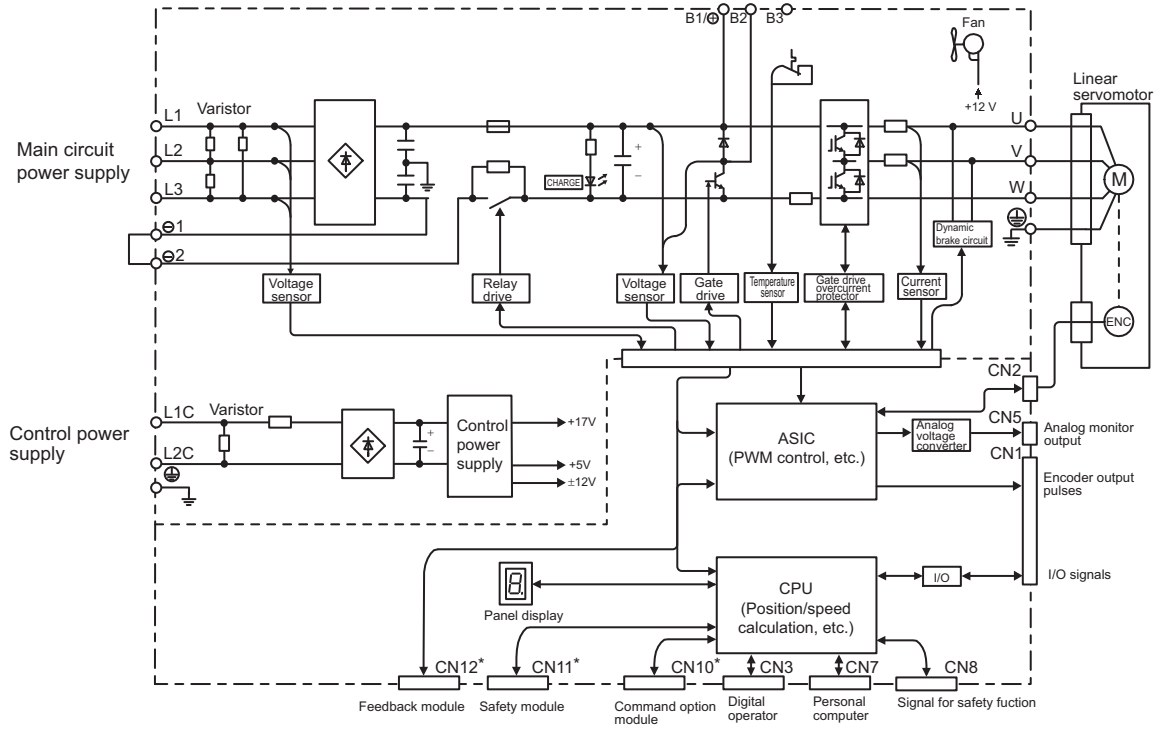

\* This external input signal is used by the option module.  
For details, refer to the manual of the connected option module.

### 1.4.6 Three-phase 200-V, SGDV-3R8AE5A, -5R5AE5A, -7R6AE5A Models

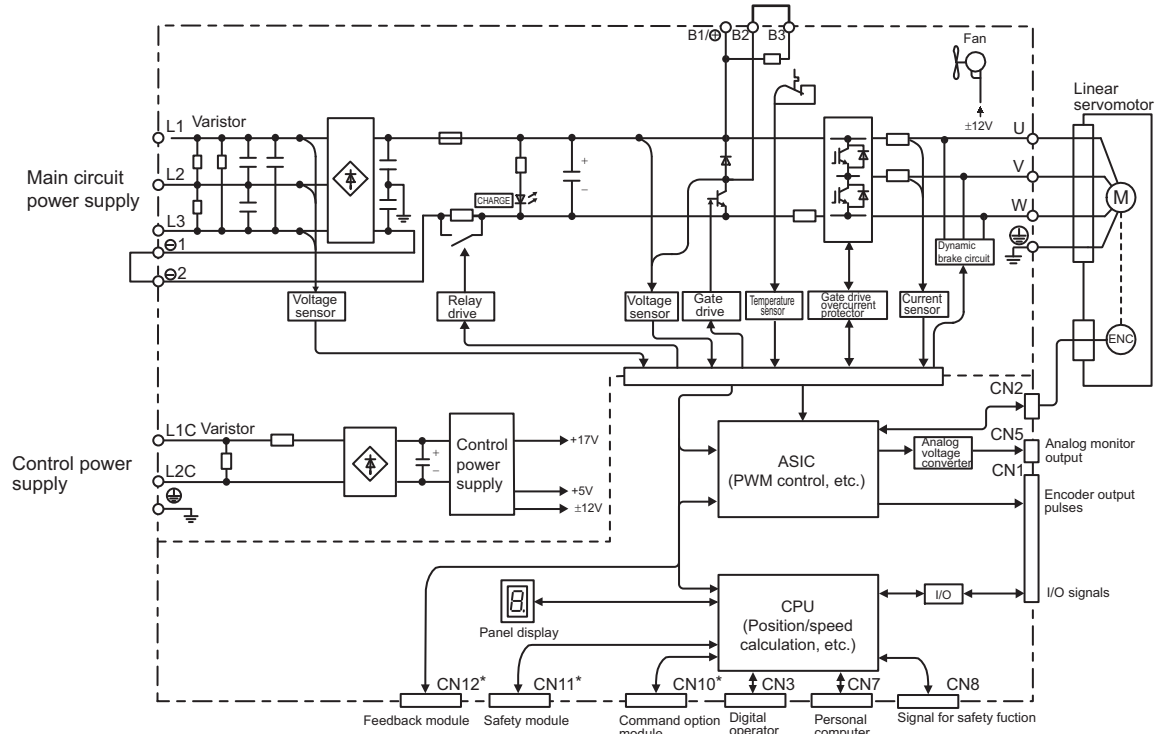

\* This external input signal is used by the option module.  
For details, refer to the manual of the connected option module.

### 1.4.7 Three-phase 200-V, SGDV-120AE5A Model

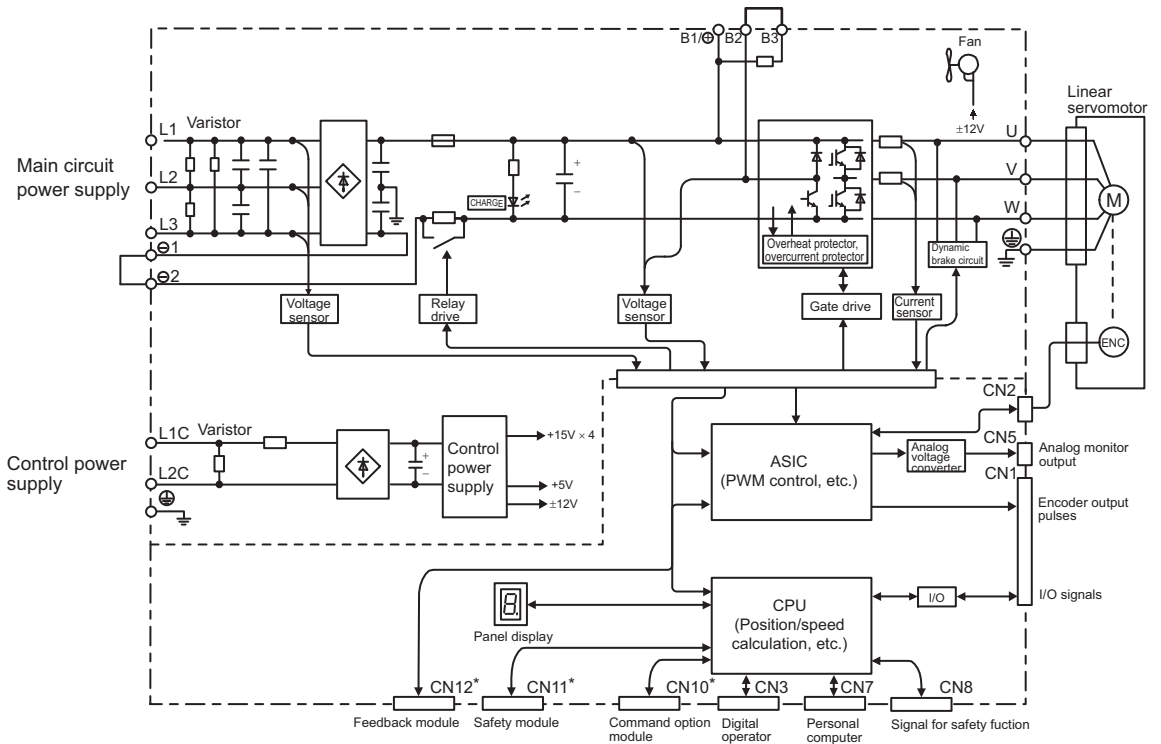

\* This external input signal is used by the option module.  
For details, refer to the manual of the connected option module.

### 1.4.8 Three-phase 200-V, SGDV-180AE5A, -200AE5A Models

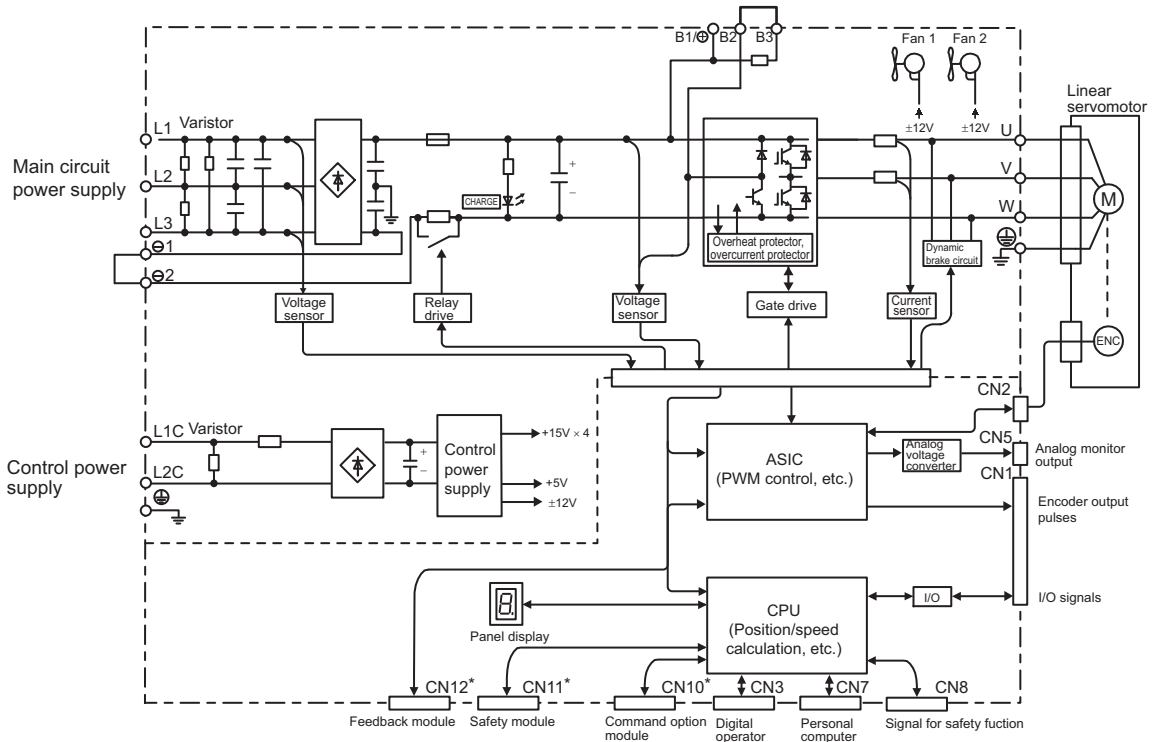

\* This external input signal is used by the option module.  
For details, refer to the manual of the connected option module.

### 1.4.9 Three-phase 200-V, SGDV-330AE5A Model

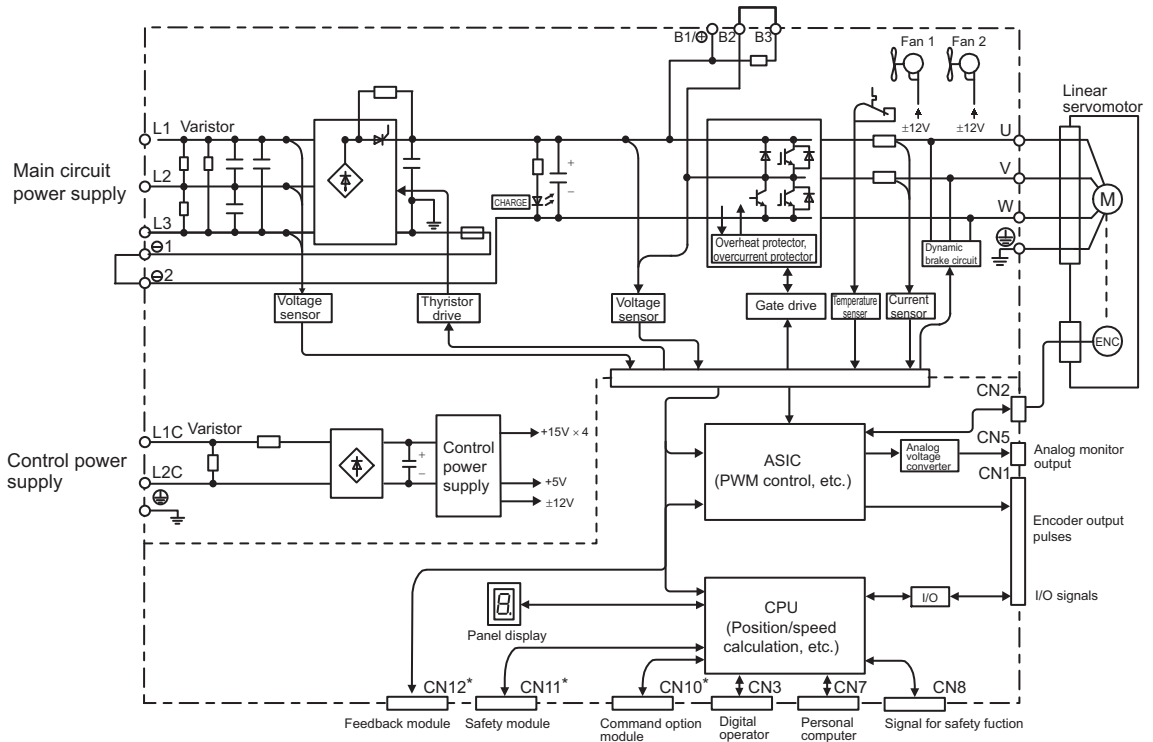

\* This external input signal is used by the option module.  
For details, refer to the manual of the connected option module.

### 1.4.10 Three-phase 200-V, SGDV-550AE5A Model

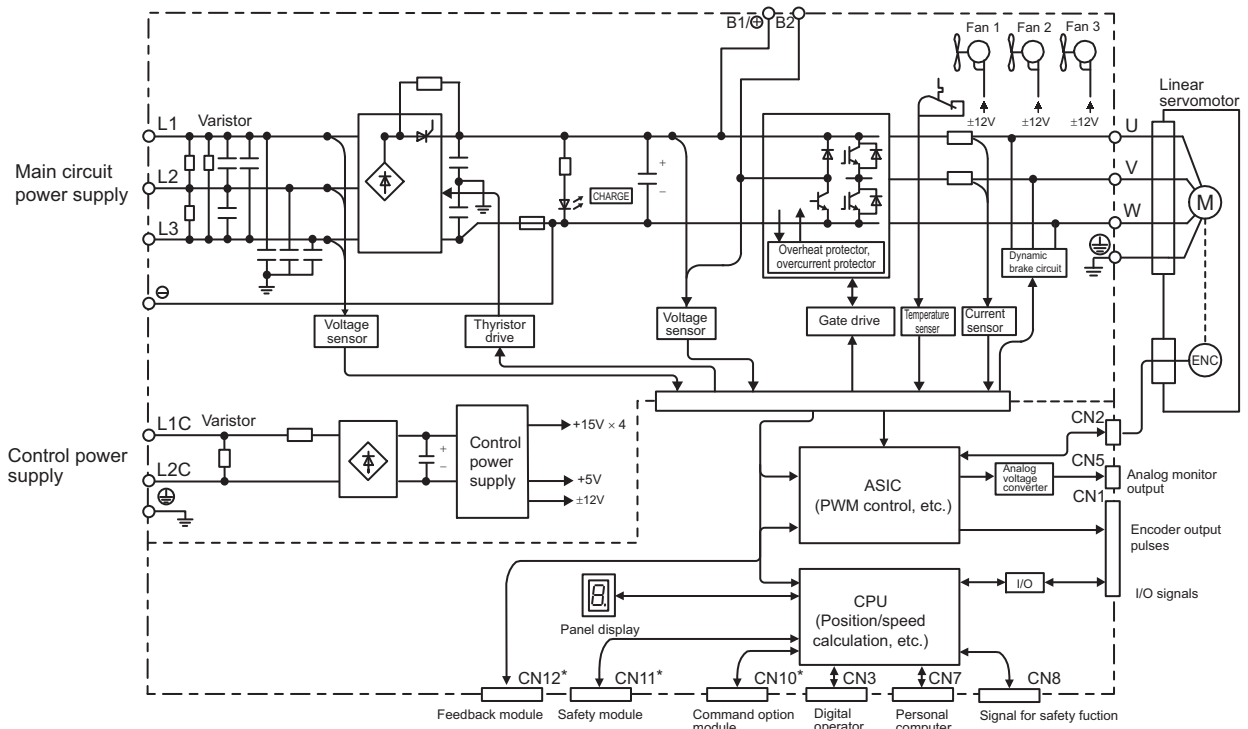

\* This external input signal is used by the option module.  
For details, refer to the manual of the connected option module.



### 1.4.11 Three-phase 400-V, SGDV-1R9DE5A, -3R5DE5A, -5R4DE5A Models

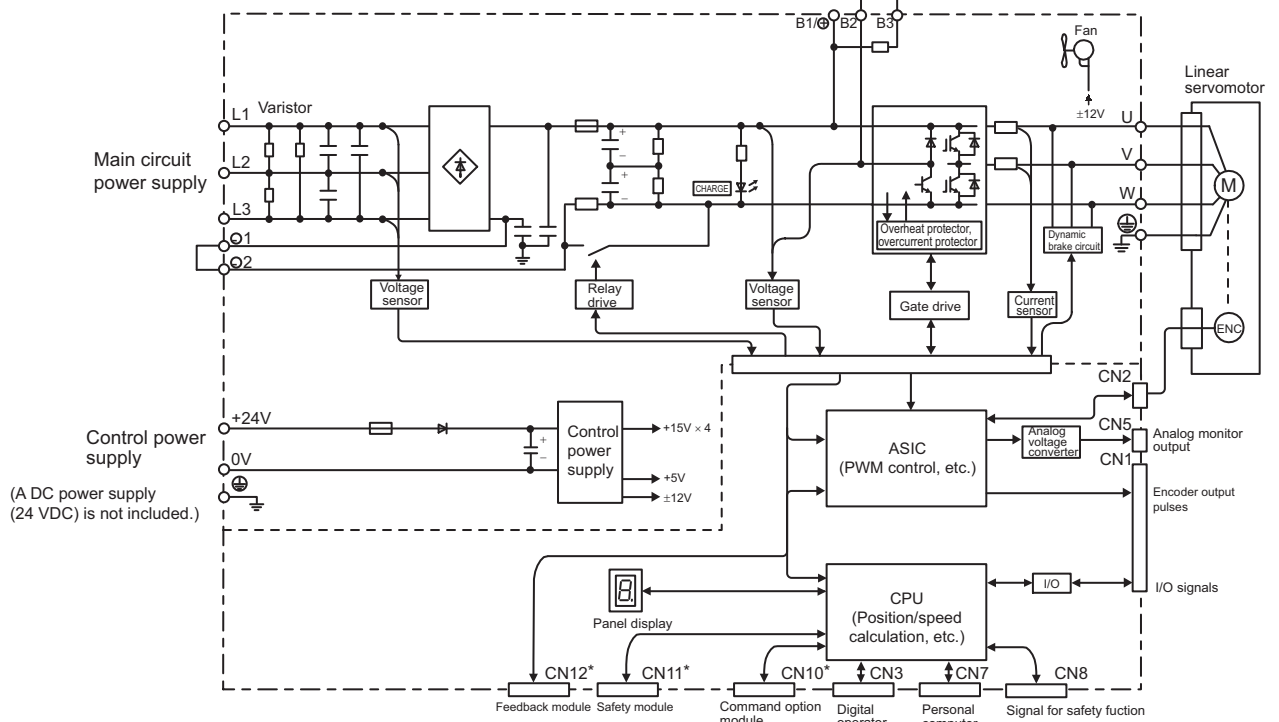

\* This external input signal is used by the option module.  
For details, refer to the manual of the connected option module.

### 1.4.12 Three-phase 400-V, SGDV-8R4DE5A, -120DE5A Models

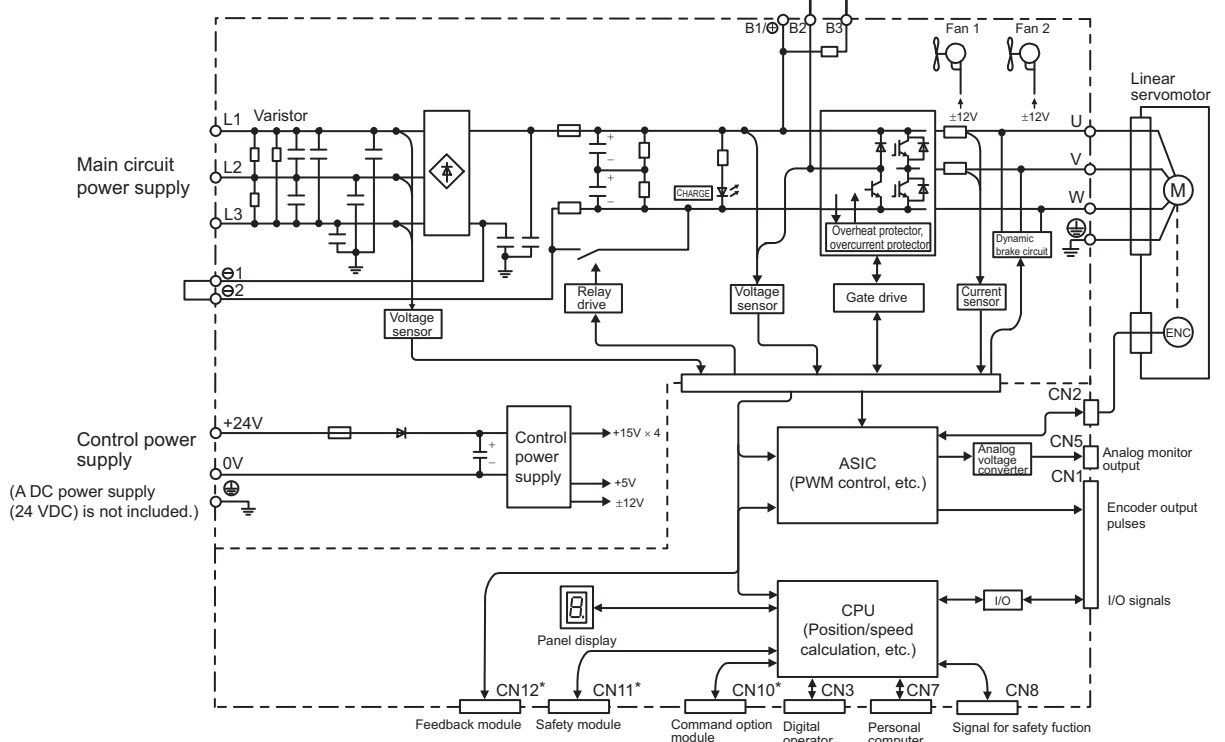

\* This external input signal is used by the option module.  
For details, refer to the manual of the connected option module.

### 1.4.13 Three-phase 400-V, SGD V-170DE5A Model

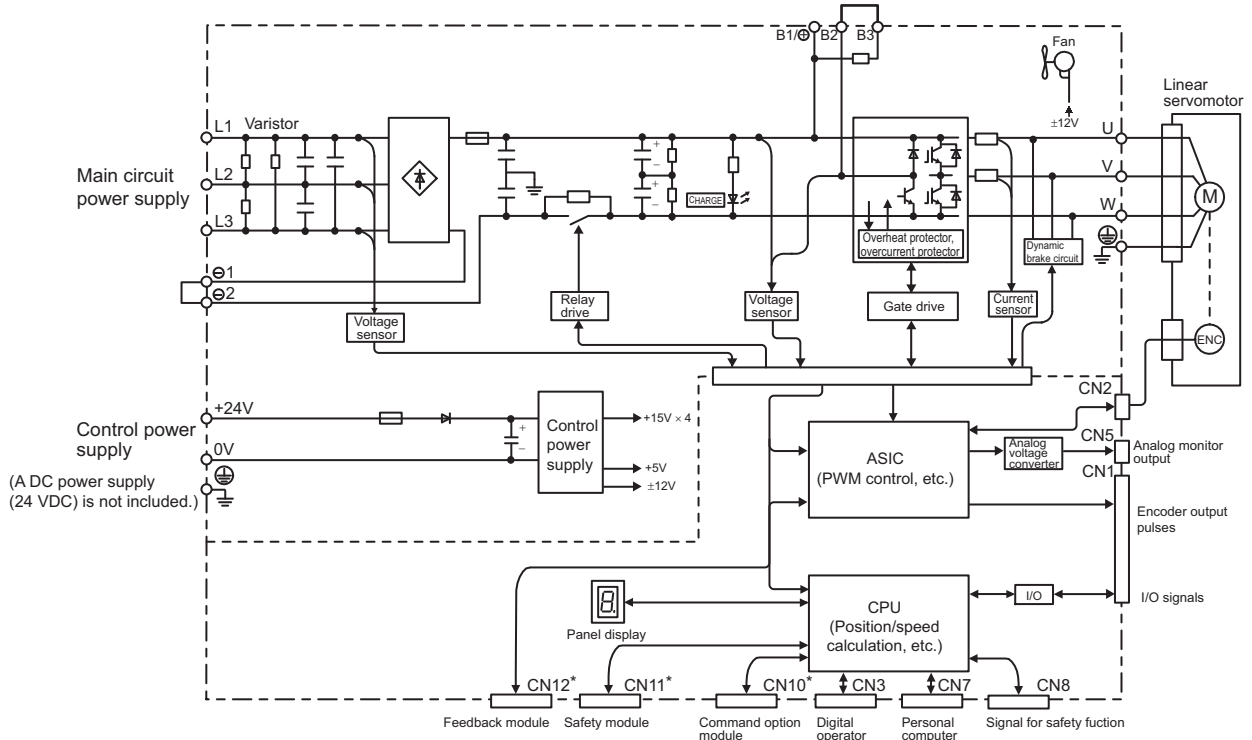

\* This external input signal is used by the option module.  
For details, refer to the manual of the connected option module.

### 1.4.14 Three-phase 400-V, SGD V-260DE5A Model

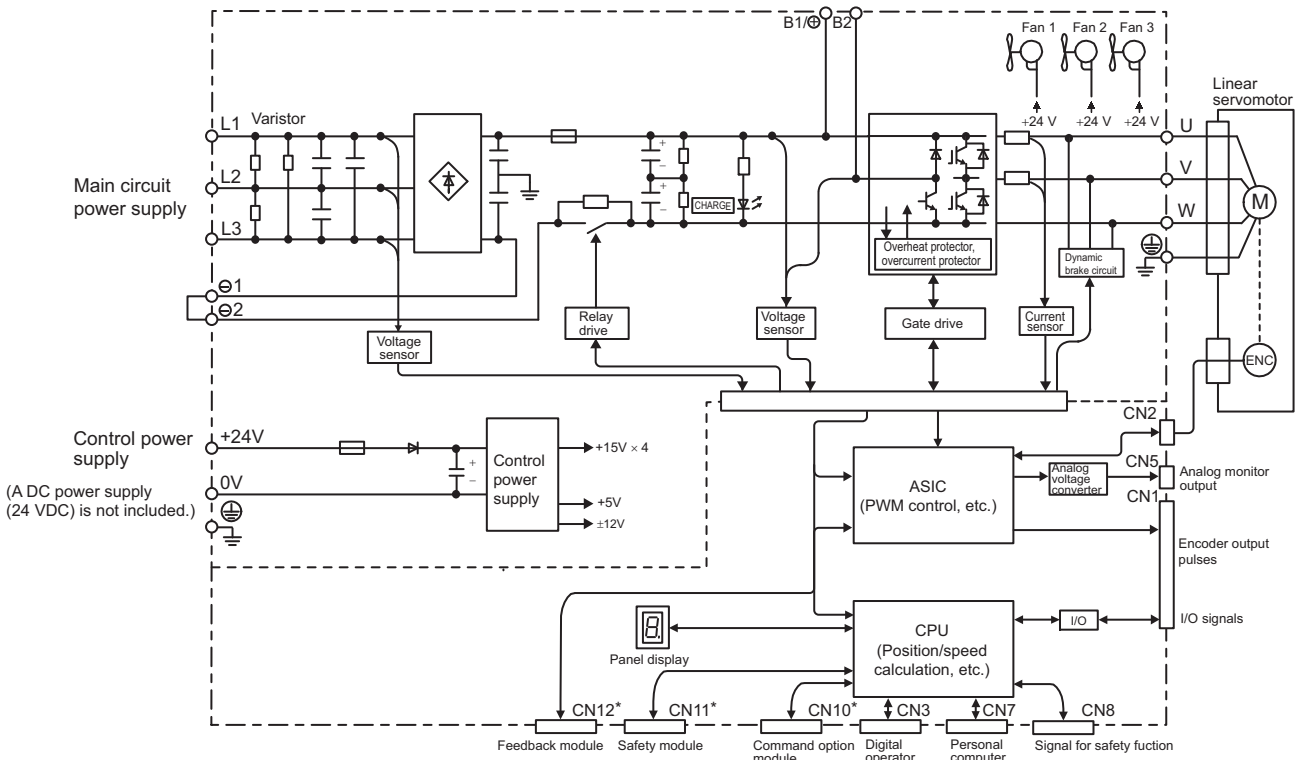

\* This external input signal is used by the option module.  
For details, refer to the manual of the connected option module.

# 1.5 Examples of Servo System Configurations

This section describes examples of basic servo system configuration.

## 1.5.1 Connecting to SGDV-□□□FE5A SERVOPACK

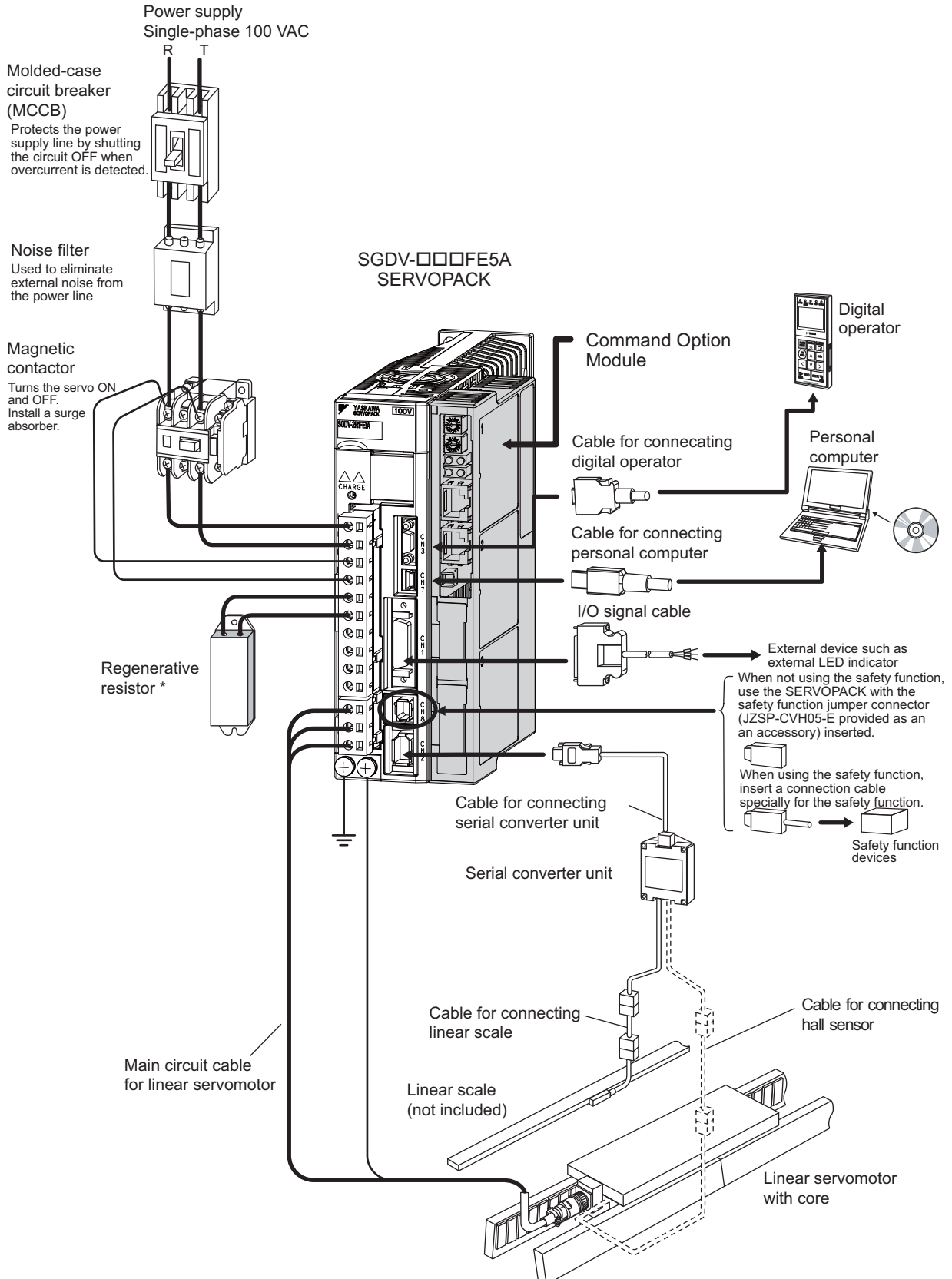

\* Before connecting an external regenerative resistor to the SERVOPACK, refer to 3.7 Regenerative Resistors Connections.

## 1.5.2 Connecting to SGDV-□□□AE5A SERVOPACK

### (1) Using a Three-phase, 200-V Power Supply

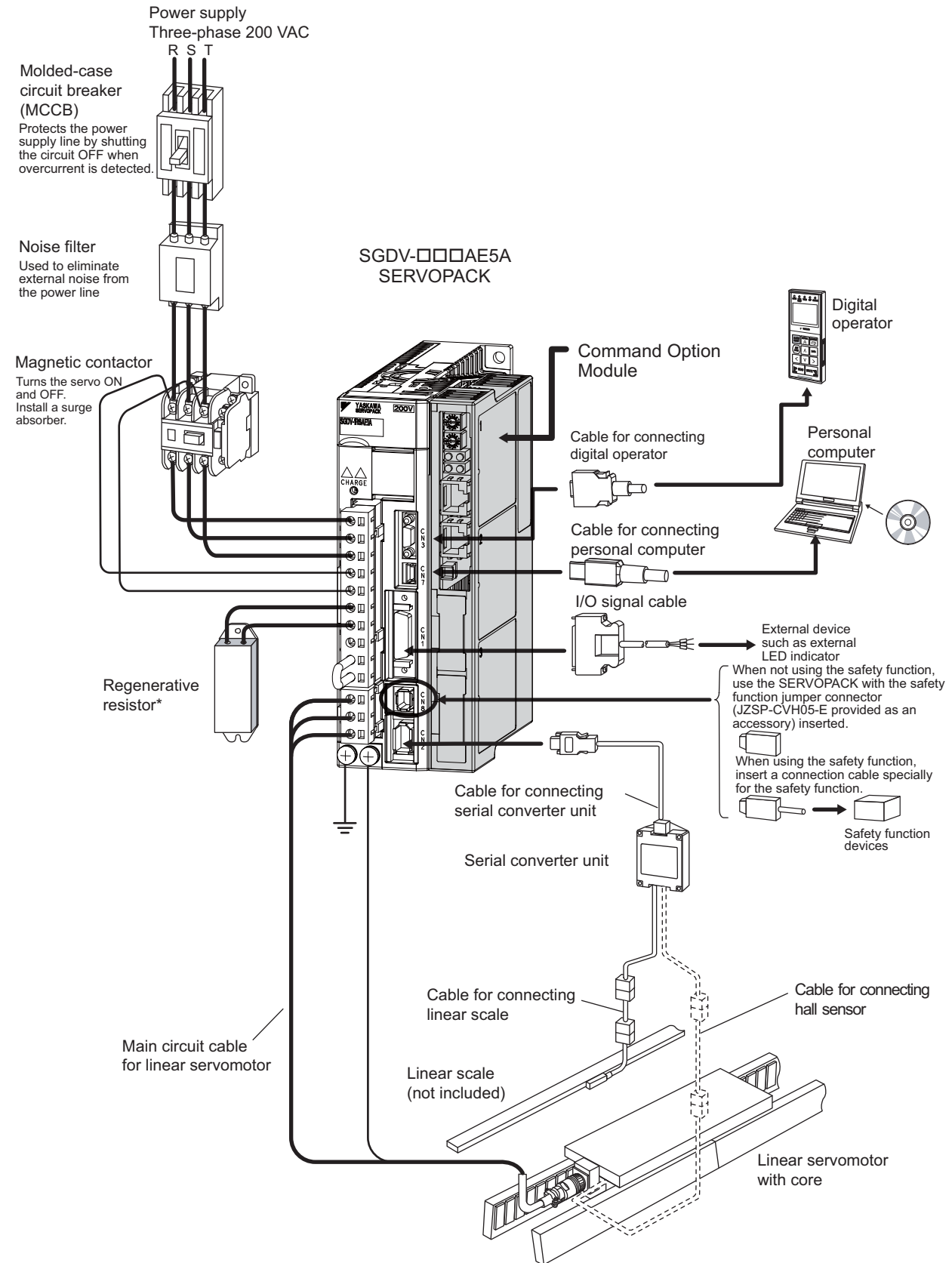

\* Before connecting an external regenerative resistor to the SERVOPACK, refer to 3.7 Regenerative Resistors Connections.

## (2) Using a Single-phase, 200-V Power Supply

The  $\Sigma$ -V Series SERVOPACK for a 200-V power supply input has input specifications for a three-phase power supply, but some models can also be used with a single-phase 200-V power supply. For details, refer to 3.1.4 *Using the SERVOPACK with Single-phase, 200-V Power Input*.

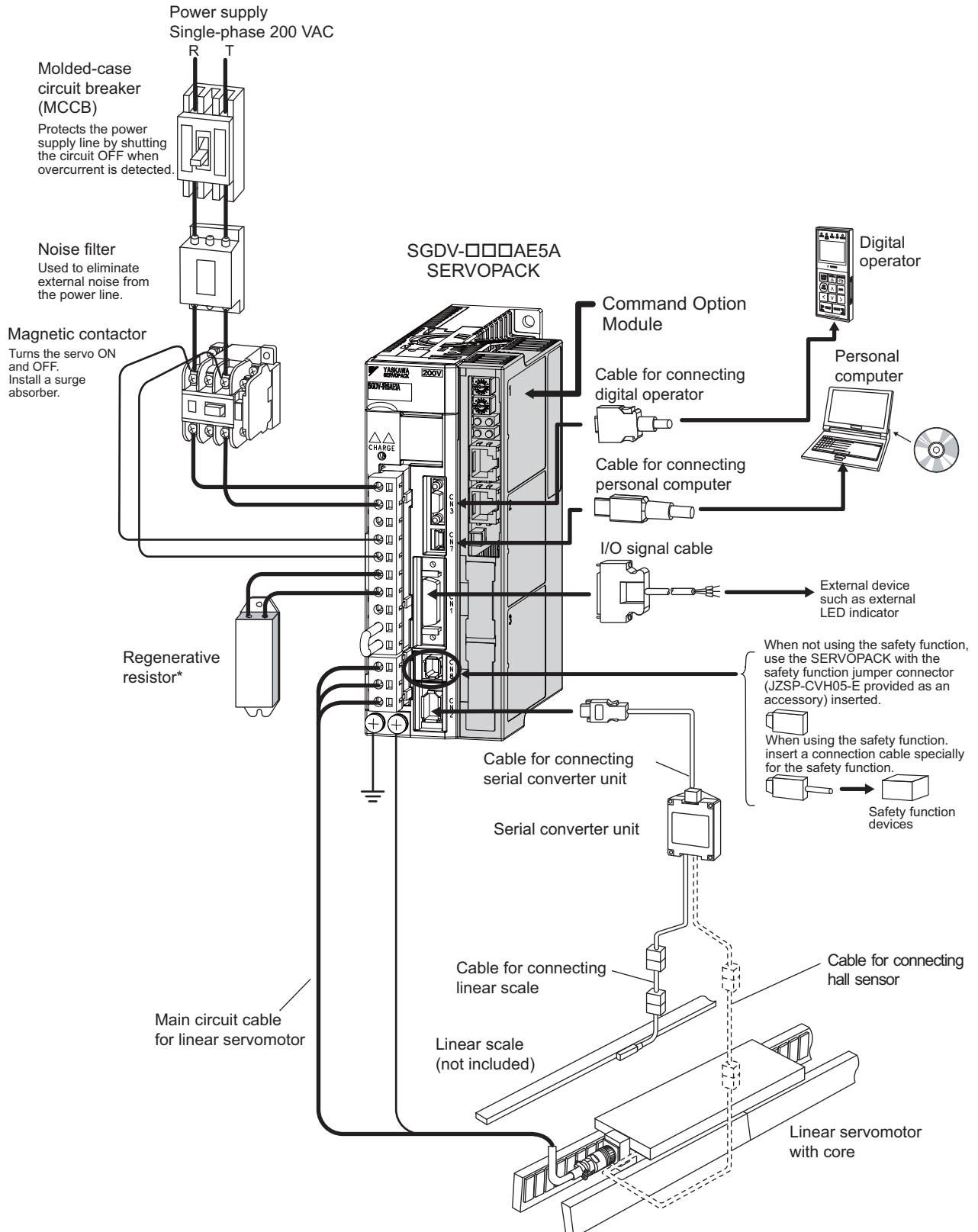

\* Before connecting an external regenerative resistor to the SERVOPACK, refer to 3.7 *Regenerative Resistors Connections*.

### 1.5.3 Connecting to SGD V-□□□DE5A SERVOPACK

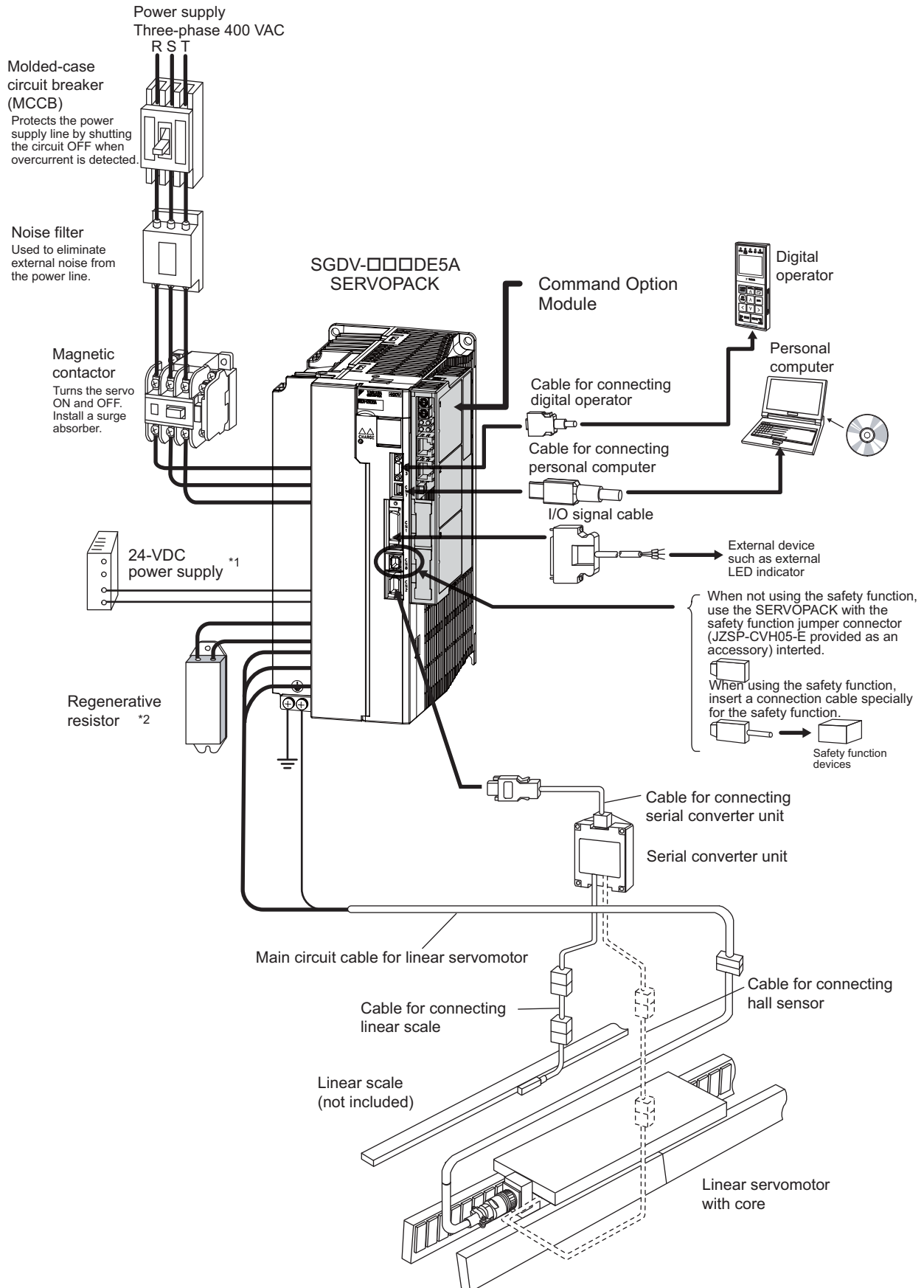

\*1. Use a 24-VDC power supply with double insulation or reinforced insulation. (The power supply is not included)  
 \*2. Before connecting an external regenerative resistor to the SERVOPACK, refer to 3.7 Regenerative Resistors Connections.

# 1.6 SERVOPACK Model Designation

Select the SERVOPACK according to the applied servomotor.

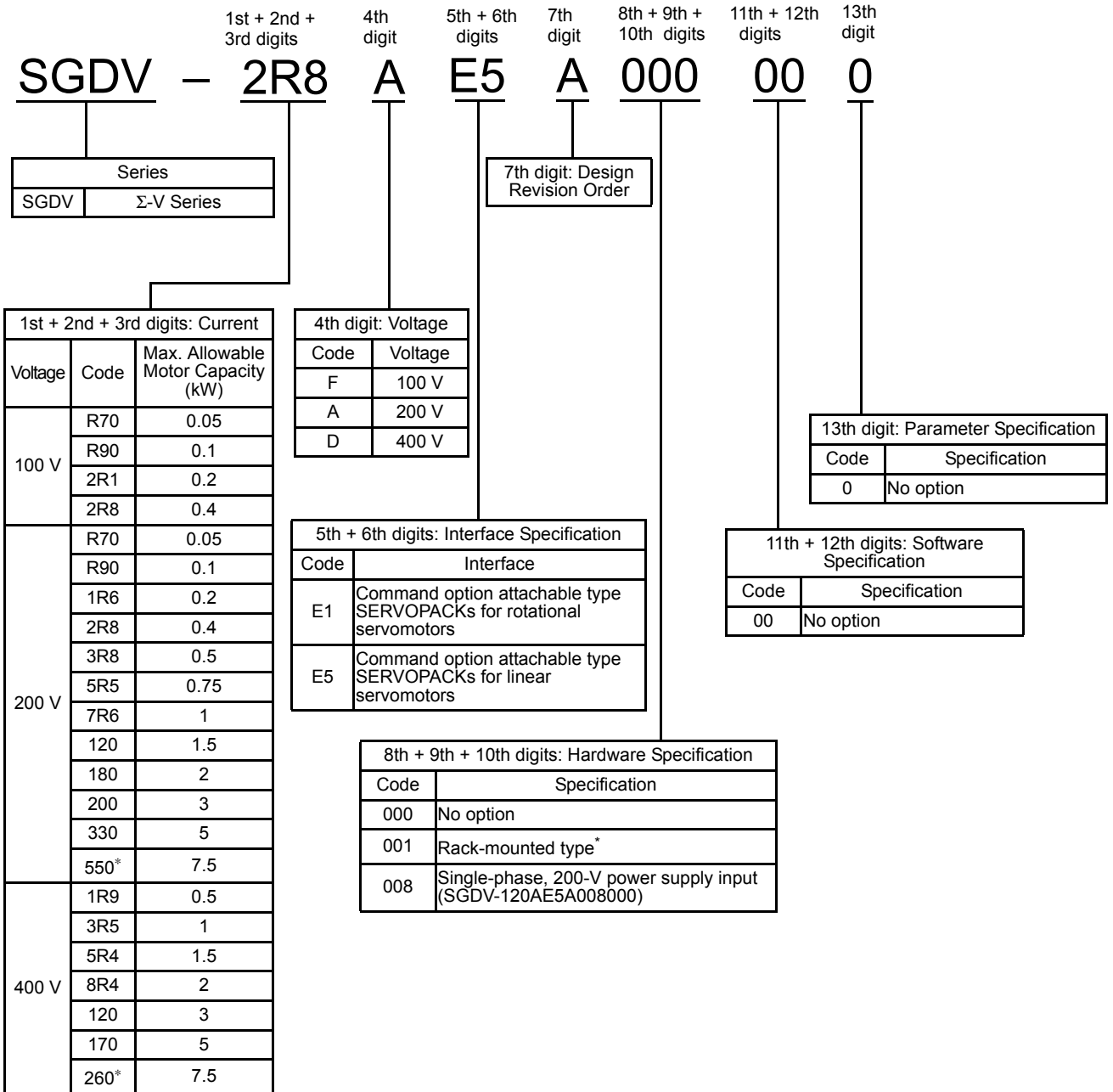

\* The SGDV-550A and -260D have air ducts for ventilation.  
 Note: If the option codes for the 8th to the 13th digits are all zero, the zeroes are omitted.

## 1.7 Inspection and Maintenance

This section describes the inspection and maintenance of SERVOPACK.

### (1) SERVOPACK Inspection

For inspection and maintenance of the SERVOPACK, follow the inspection procedures in the following table at least once every year. Other routine inspections are not required.

Item	Frequency	Procedure	Comments
Exterior	At least once a year	Check for dust, dirt, and oil on the surfaces.	Clean with compressed air.
Loose Screws		Check for loose terminal block and connector screws.	Tighten any loose screws.

### (2) SERVOPACK's Parts Replacement Schedule

The following electric or electronic parts are subject to mechanical wear or deterioration over time. To avoid failure, replace these parts at the frequency indicated.

Refer to the standard replacement period in the following table, contact your Yaskawa representative. After an examination of the part in question, we will determine whether the parts should be replaced or not.

 <b>IMPORTANT</b>	<p>The parameters of any SERVOPACKs overhauled by Yaskawa are reset to the factory settings before shipping. Be sure to confirm that the parameters are properly set before starting operation.</p>
--	---

Part	Standard Replacement Period	Operating Conditions
Cooling Fan	4 to 5 years	<ul style="list-style-type: none"> <li>• Surrounding Air Temperature: Annual average of 30°C</li> <li>• Load Factor: 80% max.</li> <li>• Operation Rate: 20 hours/day max.</li> </ul>
Smoothing Capacitor	7 to 8 years	
Other Aluminum Electrolytic Capacitor	5 years	
Relays	–	
Fuses	10 years	



---

## Panel Display and Operation of Digital Operator





2.1 Panel Display .....	2-2
2.1.1 Status Display .....	2-2
2.1.2 Alarm and Warning Display .....	2-2
2.1.3 Hard Wire Base Block Display .....	2-2
2.1.4 Displays during Overtravel .....	2-2
2.2 Utility Function Mode (Fn□□□) .....	2-3
2.3 Parameter (Pn□□□) Operation .....	2-4
2.3.1 Parameter Classifications .....	2-4
2.3.2 Parameter Notation .....	2-4
2.3.3 Parameter Setting Methods .....	2-5
2.4 Monitor Mode (Un□□□) .....	2-7

## 2.1 Panel Display

The servo status can be checked on the panel display of the SERVOPACK.  
Also, if an alarm or warning occurs, its alarm or warning number is displayed.

### 2.1.1 Status Display

The display shows the following status.

Display	Meaning
	Movement Detection (/TGON) Lights if linear servomotor speed exceeds the value set in Pn522. (Factory setting: 7 reference units)
	Base Block Lights for base block.
	Reference Input Lights when a reference is being input.
	Command Option Module Communications Status Display Lights when communications with the Command Option Module are normal.

### 2.1.2 Alarm and Warning Display

If an alarm or warning occurs, the display will change in the following order.

Example: Alarm A.E60

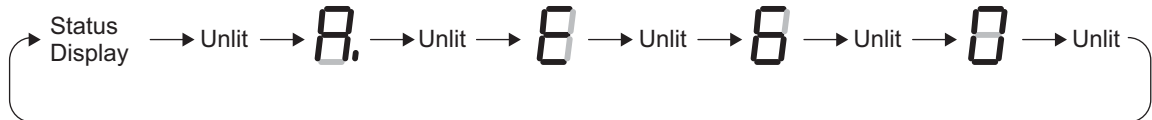

### 2.1.3 Hard Wire Base Block Display

If a hard wire base block (HWBB) occurs, the display will change in the following order.

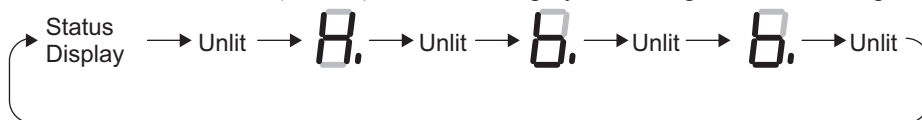

### 2.1.4 Displays during Overtravel

The display will change as shown below during overtravel.

Forward run prohibited (P-OT signal input ON):

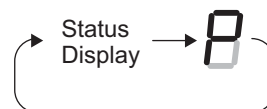

Reverse run prohibited (N-OT signal input ON):



Forward/reverse run prohibited (P-OT/N-OT signal input ON):



















## 2.2 Utility Function Mode (Fn□□□)

The setup and adjustment functions of the SERVOPACK are executed in this mode.

The digital operator displays numbers beginning with Fn.

An operation example in Utility Function Mode is shown below for Origin Search (Fn003).

Step	Display after Operation	Keys	Description
1	<pre> BB      -FUNCTION- Fn002: JOG Fn003: Z-Search Fn004: Program JOG Fn005: Prm Init           </pre>	  	Open the Utility Function Mode main menu and select Fn003.
2	<pre> BB      -Z-Search- Un000= 00000 Un002= 00000 Un003= 00774 Un00D= 00000000           </pre>		Press the  Key. The display changes to the execution display of Fn003. If the display does not change and “NO-OP” is displayed in the status display, change the following settings. <ul style="list-style-type: none"> <li>• If Write Prohibited is set in Fn010: → Change the Write Prohibited setting.</li> <li>• If a servo ON command has been entered: → Send a servo OFF command.</li> </ul>
3	<pre> RUN     -Z-Search- Un000= 00000 Un002= 00000 Un003= 00774 Un00D= 00000000           </pre>		Press the  Key. “RUN” is displayed in the status display, and power will be supplied to the linear servomotor. If “NO-OP” is displayed, one of the following statuses will be displayed: <ul style="list-style-type: none"> <li>• Main circuit power supply OFF</li> <li>• Alarm</li> <li>• Hard wire base block</li> </ul>
4	<pre> RUN     -Complete- Un000= 00000 Un002= 00000 Un003= 00000 Un00D= 00001D58           </pre>	 	Pressing the  Key will run the linear servomotor in the forward direction. Pressing the  Key will run the linear servomotor in the reverse direction. The movement direction of the linear servomotor changes according to the setting of Pn000.0. Note: Forward movement is the linear scale counting up direction. Refer to 4.2.2 <i>Linear Servomotor Movement Direction</i> for details. Press the  or  Key until the linear servomotor stops. If the origin search completed normally, “-Complete-” is displayed in the upper right corner.
5	<pre> BB      -Z-Search- Un000= 00000 Un002= 00000 Un003= 00774 Un00D= 00001D58           </pre>		When the origin search is completed, press the  Key. “BB” is displayed in the status display, and the linear servomotor turns OFF. The display “-Complete-” changes to “-Z-Search-” in the upper right corner.
6	<pre> BB      -FUNCTION- Fn002: JOG Fn003: Z-Search Fn004: Program JOG Fn005: Prm Init           </pre>		Press the  Key. The display returns to the Utility Function Mode main menu. This completes the operation.
7	After origin search operation, turn OFF the power and then turn ON again.		

## 2.3 Parameter (Pn□□□) Operation

This section describes the classifications, notation, and setting methods of parameters given in this manual.

### 2.3.1 Parameter Classifications

The Σ-V-series SERVOPACKs have two types of parameters: setup parameters for the basic settings required for operation and tuning parameters for adjusting servo performance.

Classification	Meaning	Display Method	Setting Method
Setup parameters	Parameters required for setup	Normally displayed. (Pn00B.0 = 0, factory setting)	Set each parameter.
Tuning parameters	Parameters for tuning of control gain and other values	Set Pn00B.0 to 1.	The user is generally not required to set these parameters individually.

Also, there are two notation methods for parameters: “numeric parameters” for which numeric values are set and “selection parameters” for which functions are selected.

The following sections describe each explanation method and setting method.

### 2.3.2 Parameter Notation

#### (1) Notation for Numeric Parameters

Control mode for which the parameter is valid.

Speed : Speed control

Position : Position control

Force : Force control

Pn406	Emergency Stop Force			Speed	Position	Force
	Setting Range	Setting Unit	Factory Setting	When Enabled	Classification	
	0 to 800%	1%	800%		Immediately	Setup

The number of the parameter.

Indicates setting range for the parameter.

Indicates minimum setting unit for the parameter.

Indicates parameter value before shipment (factory setting).

Indicates if the power has to be turned OFF and ON again to validate setting changes.

Indicates the parameter classification.

#### (2) Notation for Selection Parameters

Parameter	Meaning	When Enabled	Classification
Pn50A	n.2□□□	After restart	Setup
	n.8□□□		

The number of the parameter.





























n.□□□□ indicates the function selection. The numbers in the boxes indicate the set values for each digit. This example indicates the 4th digit is 8.

This section explains the details of the function selection.

### 2.3.3 Parameter Setting Methods





















#### (1) Setting Method for Numeric Parameters

The following example shows how to change the setting of parameter Pn383 (JOG speed) to 1000 mm/s.

Step	Display after Operation	Keys	Description
1	<pre> BB          -PRM/MON- Un000= 00000 Un002= 00000 Un008= 00000 Un00D=00000000           </pre>		Press the  Key to select the Parameter/Monitor Mode.
2	<pre> BB          -PRM/MON- Un000= 00000 Un002= 00000 Un008= 00000 Un00D=00000000           </pre>	 	Press the  or  Key to move the cursor to “Un.”
3	<pre> BB          -PRM/MON- Pn000=n.0000 Un002= 00000 Un008= 00000 Un00D=00000000           </pre>	 	Press the  or  Key to change “Un” to “Pn.”
4	<pre> BB          -PRM/MON- Pn000=n.0000 Un002= 00000 Un008= 00000puls e Un00D=00000000           </pre>		Press the  Key to move the cursor to the column on the right of “Pn.”
5	<pre> BB          -PRM/MON- Pn383=00500 Un002= 00000 Un008= 00000 Un00D=00000000           </pre>	   	Press the arrow keys to display “Pn383”. To move the cursor:  ,  Key To change the settings:  ,  Key
6	<pre> BB          -PRM/MON- Pn383=0050<u>0</u> Un002= 00000 Un008= 00000 Un00D=00000000           </pre>		Press the  Key to move the cursor to the one’s place of Pn383.
7	<pre> BB          -PRM/MON- Pn383=00<u>5</u>00 Un002= 00000 Un008= 00000 Un00D=00000000           </pre>		Press the  Key twice to move the cursor to the hundred’s place of Pn383.
8	<pre> BB          -PRM/MON- Pn383=01<u>0</u>00 Un002= 00000 Un008= 00000 Un00D=00000000           </pre>		Press the  Key five times to change the setting to “1000.”
9	<pre> BB          -PRM/MON- Pn38<u>3</u>=01000 Un002= 00000 Un008= 00000 Un00D=00000000           </pre>		Press the  Key to write the settings.

## (2) Setting Method for Selection Parameters

The following example shows how to use application function selection switch 1 (Pn001) to change the setting for the stopping method at servo OFF and alarm occurrence from stopping using DB (Pn001 = n.0000) to stopping without DB (Pn001 = n.0002).

Step	Display after Operation	Keys	Description
1	<pre> BB          -PRM/MON- Un000= 00000 Un002= 00000 Un008= 00000 Un00D=00000000           </pre>		Press the  Key to select the Parameter/Monitor Mode.
2	<pre> BB          -PRM/MON- Un00<u>0</u>= 00000 Un002= 00000 Un008= 00000 Un00D=00000000           </pre>	 	Press the  or  Key to move the cursor to "Un."
3	<pre> BB          -PRM/MON- Pn00<u>0</u>=n.0000 Un002= 00000 Un008= 00000 Un00D=00000000           </pre>	 	Press the  or  Key to change "Un" to "Pn."
4	<pre> BB          -PRM/MON- Pn00<u>0</u>=n.0000 Un002= 00000 Un008= 00000 Un00D=00000000           </pre>		Press the  Key three times to move the cursor to the left of "n."
5	<pre> BB          -PRM/MON- Pn00<u>1</u>=n.0000 Un002= 00000 Un008= 00000 Un00D=00000000           </pre>		Press the  Key to display "Pn001."
6	<pre> BB          -PRM/MON- Pn001=n.000<u>0</u> Un002= 00000 Un008= 00000 Un00D=00000000           </pre>		Press the  Key to move the cursor to the right edge.
7	<pre> BB          -PRM/MON- Pn001=n.000<u>2</u> Un002= 00000 Un008= 00000 Un00D=00000000           </pre>		Press the  Key twice to change the setting of "n.0000" to "n.0002."
8	<pre> BB          -PRM/MON- Pn001=n.000<u>2</u> Un002= 00000 Un008= 00000 Un00D=00000000           </pre>		Press the  Key to write the settings.

## 2.4 Monitor Mode (Un□□□)

The monitor mode can be used for monitoring the reference values, I/O signal status, and SERVOPACK internal status.

For details, refer to *7.2 Monitor Displays*.

The digital operator display numbers begin with Un.

The following four Un numbers are displayed with the factory settings.

BB		-PRM/MON-
Un000	=	00000
Un002	=	00000
Un008	=	00000
Un00D	=	00000000

← Shows the setting of Un000 (motor speed) as 0 mm/s.

## Wiring and Connection

3.1	Main Circuit Wiring	3-2
3.1.1	Main Circuit Terminals	3-2
3.1.2	Using a Standard Power Supply Input (Single-phase 100-V, Three-phase 200-V, or Three-phase 400-V)	3-3
3.1.3	General Precautions for Wiring	3-11
3.1.4	Using the SERVOPACK with Single-phase, 200-V Power Input	3-12
3.1.5	Using the SERVOPACK with a DC Power Input	3-15
3.1.6	Using More Than One SERVOPACK	3-17
3.2	I/O Signal Connections	3-18
3.2.1	I/O Signal (CN1) Names and Functions	3-18
3.2.2	Safety Function Signal (CN8) Names and Functions	3-19
3.2.3	Example of I/O Signal Connections	3-20
3.3	I/O Signal Allocations	3-21
3.3.1	Input Signal Allocations	3-21
3.3.2	Output Signal Allocation	3-23
3.4	Connection to Host Controller	3-24
3.4.1	Sequence Input Circuits	3-24
3.4.2	Sequence Output Circuits	3-26
3.5	Wiring Communications Using Command Option Modules	3-28
3.6	Linear Scale Connections	3-29
3.6.1	Linear Scale Signal (CN2) Names and Functions	3-29
3.6.2	Connection Example of a Linear Scale	3-29
3.6.3	Serial Converter Unit Specifications	3-31
3.7	Regenerative Resistors Connections	3-33
3.7.1	Connecting Regenerative Resistors	3-33
3.7.2	Setting Regenerative Resistor Capacity	3-35
3.8	Noise Control and Measures for Harmonic Suppression	3-36
3.8.1	Wiring for Noise Control	3-36
3.8.2	Precautions on Connecting Noise Filter	3-38
3.8.3	Connecting AC/DC Reactor for Harmonic Suppression	3-40



## 3.1 Main Circuit Wiring

The names and specifications of the main circuit terminals are given on the following page.

This section also describes the general precautions for wiring and precautions under special environments.

### 3.1.1 Main Circuit Terminals

The names and specifications are shown in the following table.

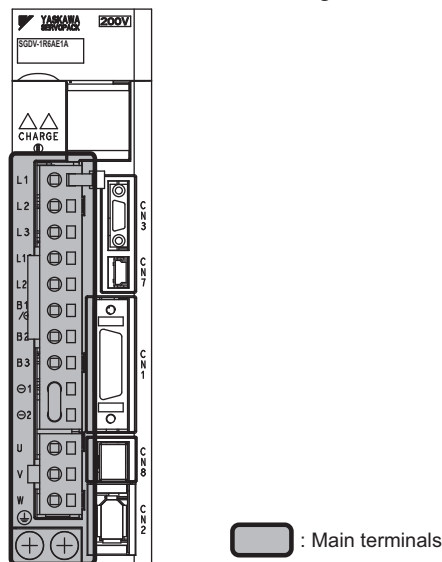

Terminal Symbols	Name	Model SGD□-□□□□	Description
L1, L2	Main circuit input terminals	□□□F	Single-phase 100 to 115 V, +10% to -15% (50/60 Hz)
L1, L2, L3		□□□A	Three-phase 200 to 230 V, +10% to -15% (50/60 Hz)
		□□□D	Three-phase 380 to 480 V, +10% to -15% (50/60 Hz)
L1C, L2C	Control power input terminals	□□□F	Single-phase 100 to 115 V, +10% to -15% (50/60 Hz)
		□□□A	Single-phase 200 to 230 V, +10% to -15% (50/60 Hz)
24 V, 0 V		□□□D	24 VDC, ±15%
B1/ ⊕, B2*1	External regenerative resistor terminals	R70F, R90F, 2R1F, 2R8F, R70A, R90A, 1R6A, 2R8A	If the regenerative capacity is insufficient, connect an external regenerative resistor (option) between B1/ ⊕ and B2.
		3R8A, 5R5A, 7R6A, 120A, 180A, 200A, 330A, 1R9D, 3R5D, 5R4D, 8R4D, 120D, 170D	Remove the lead or short bar that is short-circuiting between B2 and B3, and connect an external regenerative resistor between B1/ ⊕ and B2 only if the internal regenerative capacity is insufficient. Purchase an external regenerative resistor separately.
		550A, 260D	Connect a regenerative resistor unit between B1/ ⊕ and B2. Purchase a regenerative resistor unit separately.
⊕ 1, ⊕ 2*2	DC reactor connection terminal for power supply harmonic suppression	□□□A □□□D	If a countermeasure against power supply harmonic waves is needed, connect a DC reactor between ⊕ 1 and ⊕ 2.

Terminal Symbols	Name	Model SGD□-□□□□	Description
B1/ ⊕	Main circuit plus terminal	□□□A □□□D	Use when DC power supply input is used.
⊖ 2 or ⊖	Main circuit minus terminal	□□□A □□□D	
U, V, W	Linear servomotor connection terminals		Use for connecting to the linear servomotor.
⊕	Ground terminals (x2)		Use for connecting the power supply ground terminal and linear servomotor ground terminal.

\*1. Do not short-circuit the B1/ ⊕ and B2 terminals. Doing so may damage the SERVOPACK.

\*2. The ⊖ 1 and ⊖ 2 terminals are short-circuited with a jumper at the factory.

### 3.1.2 Using a Standard Power Supply Input (Single-phase 100-V, Three-phase 200-V, or Three-phase 400-V)

#### (1) Wire Types

Use the following type of wire for main circuit.

Cable Type		Allowable Conductor Temperature °C
Symbol	Name	
IV	600 V polyvinyl chloride insulated wire	60
HIV	600 V grade heat-resistant polyvinyl chloride insulated wire	75

The following table shows the wire sizes and allowable currents for three wires. Use wires with specifications equal to or less than those shown in the table.

- 600 V grade heat-resistant polyvinyl chloride insulated wire (HIV)

AWG Size	Nominal Cross Section Diameter (mm <sup>2</sup> )	Configuration (Number of Wires/mm <sup>2</sup> )	Conductive Resistance (Ω/km)	Allowable Current at Surrounding Air Temperature (A)		
				30°C	40°C	50°C
20	0.5	19/0.18	39.5	6.6	5.6	4.5
19	0.75	30/0.18	26.0	8.8	7.0	5.5
18	0.9	37/0.18	24.4	9.0	7.7	6.0
16	1.25	50/0.18	15.6	12.0	11.0	8.5
14	2.0	7/0.6	9.53	23	20	16
12	3.5	7/0.8	5.41	33	29	24
10	5.5	7/1.0	3.47	43	38	31
8	8.0	7/1.2	2.41	55	49	40
6	14.0	7/1.6	1.35	79	70	57
4	22.0	7/2.0	0.85	91	81	66

Note: The values in the table are for reference only.

## (2) SERVOPACK Main Circuit Wire

This section describes the wire used for the SERVOPACK main circuit.

 <b>IMPORTANT</b>	<ol style="list-style-type: none"> <li>1. Wire sizes are selected for three cables per bundle at 40°C surrounding air temperature with the rated current.</li> <li>2. Use a wire with a minimum withstand voltage of 600 V for the main circuit.</li> <li>3. If wires are bundled in PVC or metal ducts, take into account the reduction of the allowable current.</li> <li>4. Use a heat-resistant wire under high surrounding air or panel temperatures, where polyvinyl chloride insulated wires will rapidly deteriorate.</li> </ol>
---	--

### ■ Single-phase, 100 V

Terminal Symbols	Name	SERVOPACK Model SGD□V-□□□F			
		R70	R90	2R1	2R8
L1, L2	Main circuit power input terminals	HIV1.25		HIV2.0	
L1C, L2C	Control power input terminals	HIV1.25			
U, V, W	Servomotor connection terminals	HIV1.25			
B1/⊕, B2	External regenerative resistor connection terminals	HIV1.25			
⊕	Ground terminal	HIV2.0 or higher			

### ■ Three-phase, 200 V

Terminal Symbols	Name	SERVOPACK Model SGD□V-□□□A										
		R70	R90	1R6	2R8	3R8	5R5	7R6	120	180	200	330
L1, L2, L3	Main circuit power input terminals	HIV1.25			HIV2.0				HIV3.5		HIV5.5	HIV14.0
L1C, L2C	Control power input terminals	HIV1.25										
U, V, W	Servomotor connection terminals	HIV1.25			HIV2.0				HIV3.5	HIV5.5	HIV8.0	HIV14.0
B1/⊕, B2	External regenerative resistor connection terminals	HIV1.25						HIV2.0	HIV3.5	HIV5.5	HIV8.0	
⊕	Ground terminal	HIV2.0 or higher										

### ■ Three-phase, 400 V

Terminal Symbols	Name	SERVOPACK Model SGD□V-□□□D						
		1R9	3R5	5R4	8R4	120	170	260
L1, L2, L3	Main circuit power input terminals	HIV1.25			HIV2.0		HIV3.5	HIV5.5
24 V, 0 V	Control power input terminals	HIV1.25						
U, V, W	Servomotor connection terminals	HIV1.25			HIV2.0		HIV3.5	HIV5.5
B1/⊕, B2 (B1, B2)	External regenerative resistor connection terminals	HIV1.25				HIV2.0	HIV3.5	
⊕	Ground terminal	HIV2.0 or higher						

### (3) Typical Main Circuit Wiring Examples

Note the following points when designing the power ON sequence.

- Design the power ON sequence so that main power is turned OFF when a servo alarm signal is output.
- The ALM signal is output for five seconds max. (1Ry is OFF) when the power is turned ON. Take this into consideration when designing the power ON sequence. Also, use this relay to turn off the main power for the SERVOPACK.

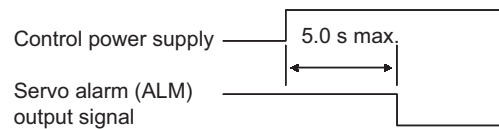

- Select the power supply specifications for the parts in accordance with the input power supply.



**IMPORTANT**

- When turning ON the control power supply and the main circuit power supply, turn them ON at the same time or after the control power supply. When turning OFF the power supplies, first turn the power for the main circuit OFF and then turn OFF the control power supply.

The typical main circuit wiring examples are shown below.



**WARNING**

- Do not touch the power terminals after turning OFF the power. High voltage may still remain in the SERVOPACK. When the voltage is discharged, the charge indicator will turn OFF. Make sure the charge indicator is OFF before starting wiring or inspections.

■ Single-phase 100 V, SGDV-□□□F (SGDV-R70F, R90F, 2R1F, 2R8F)

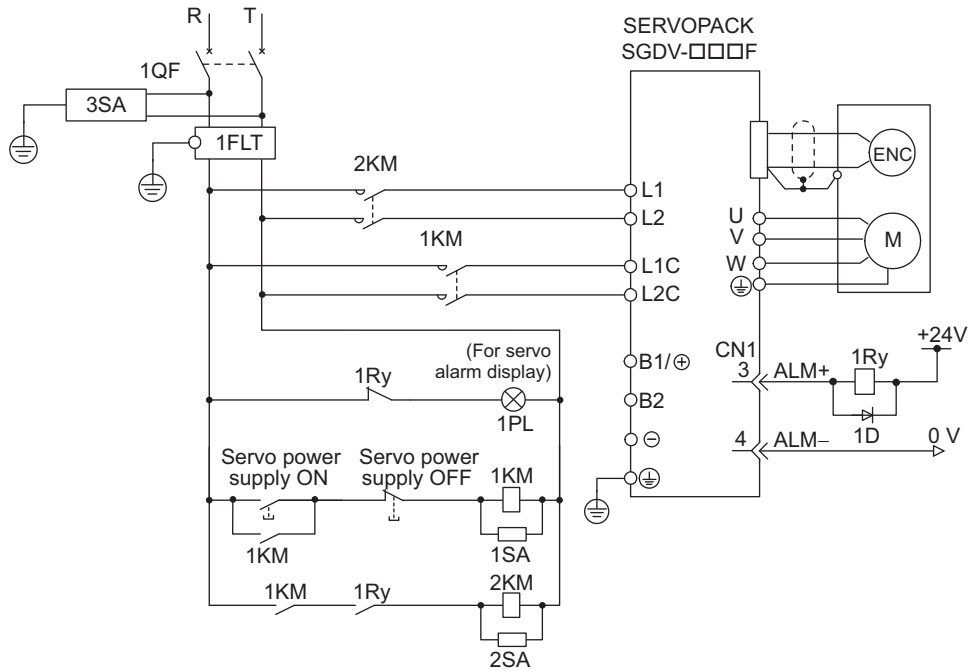

- |  |                     |
|--|---------------------|
| 1QF: Molded-case circuit breaker                   | 1PL: Indicator lamp |
| 1FLT: Noise filter                                 | 1SA: Surge absorber |
| 1KM: Magnetic contactor (for control power supply) | 2SA: Surge absorber |
| 2KM: Magnetic contactor (for main power supply)    | 3SA: Surge absorber |
| 1Ry: Relay   | 1D: Flywheel diode  |

■ Three-phase 200 V, SGDV-□□□A

- SGDV-R70A, R90A, 1R6A, 2R8A, 3R8A, 5R5A, 7R6A, 120A, 180A, 200A, 330A

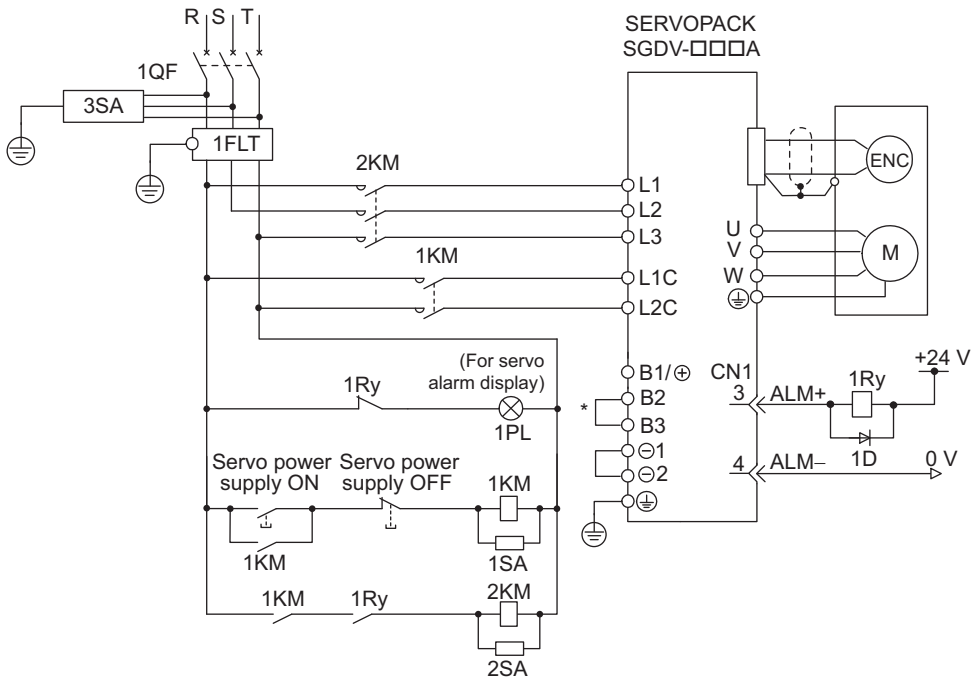

- |  |                     |
|--|---------------------|
| 1QF: Molded-case circuit breaker                   | 1PL: Indicator lamp |
| 1FLT: Noise filter                                 | 1SA: Surge absorber |
| 1KM: Magnetic contactor (for control power supply) | 2SA: Surge absorber |
| 2KM: Magnetic contactor (for main power supply)    | 3SA: Surge absorber |
| 1Ry: Relay   | 1D: Flywheel diode  |

\* For SGDV-R70A, -R90A, -1R6A, -2R8A, terminals B2 and B3 are not short-circuited.

• SGDV-550A

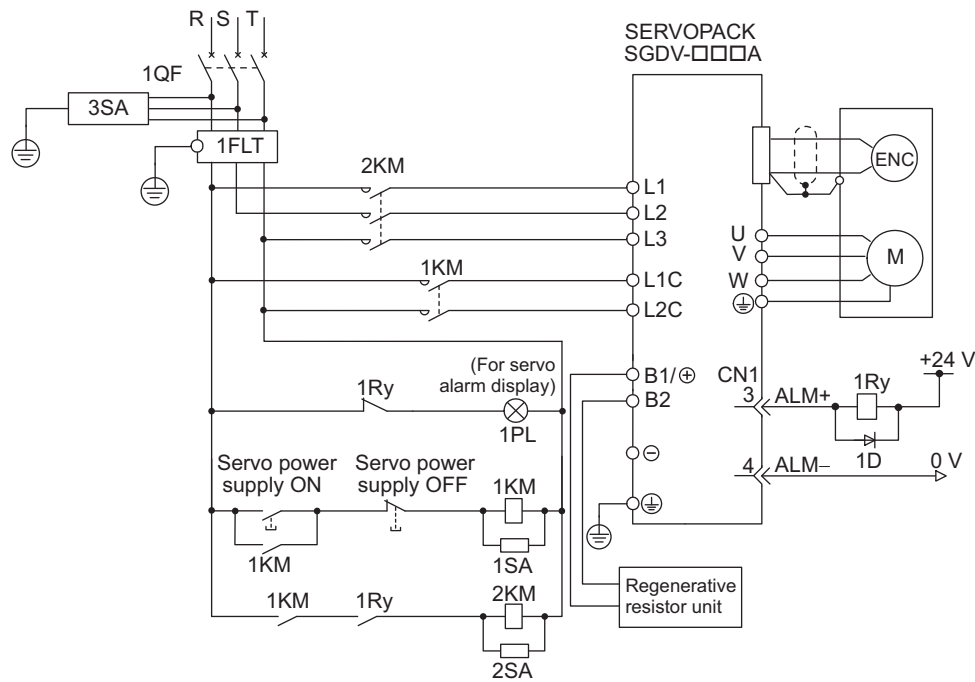

- |  |                     |
|--|---------------------|
| 1QF: Molded-case circuit breaker                   | 1PL: Indicator lamp |
| 1FLT: Noise filter                                 | 1SA: Surge absorber |
| 1KM: Magnetic contactor (for control power supply) | 2SA: Surge absorber |
| 2KM: Magnetic contactor (for main power supply)    | 3SA: Surge absorber |
| 1Ry: Relay   | 1D: Flywheel diode  |

■ Three-phase 400 V, SGDV-□□□□D

- SGDV-1R9D, 3R5D, 5R4D, 8R4D, 120D, 170D

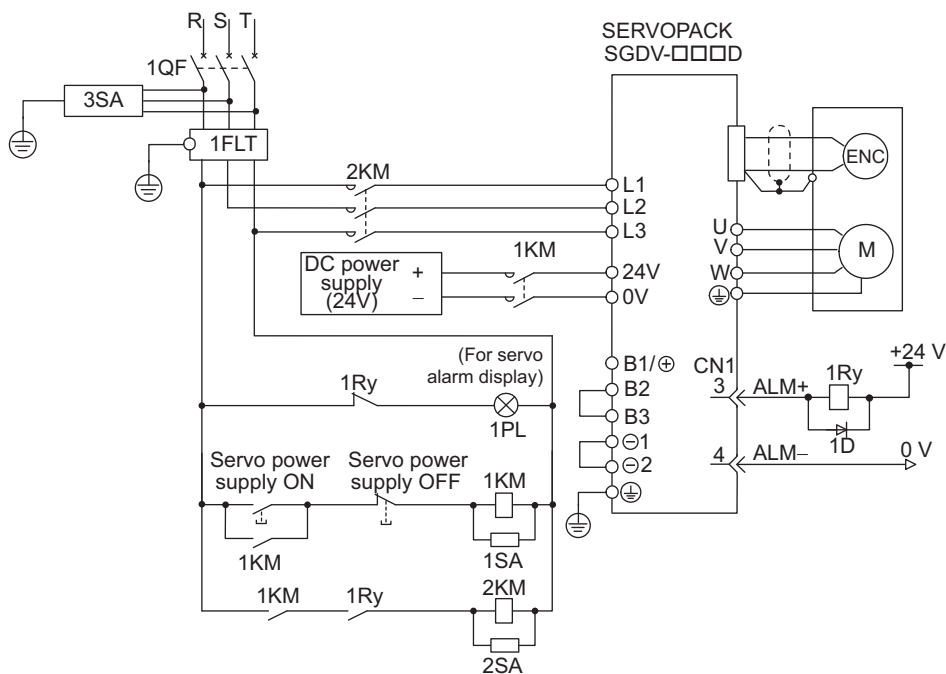

- |  |                     |
|--|---------------------|
| 1QF: Molded-case circuit breaker                   | 1PL: Indicator lamp |
| 1FLT: Noise filter                                 | 1SA: Surge absorber |
| 1KM: Magnetic contactor (for control power supply) | 2SA: Surge absorber |
| 2KM: Magnetic contactor (for main power supply)    | 3SA: Surge absorber |
| 1Ry: Relay   | 1D: Flywheel diode  |

• SGD V-260D

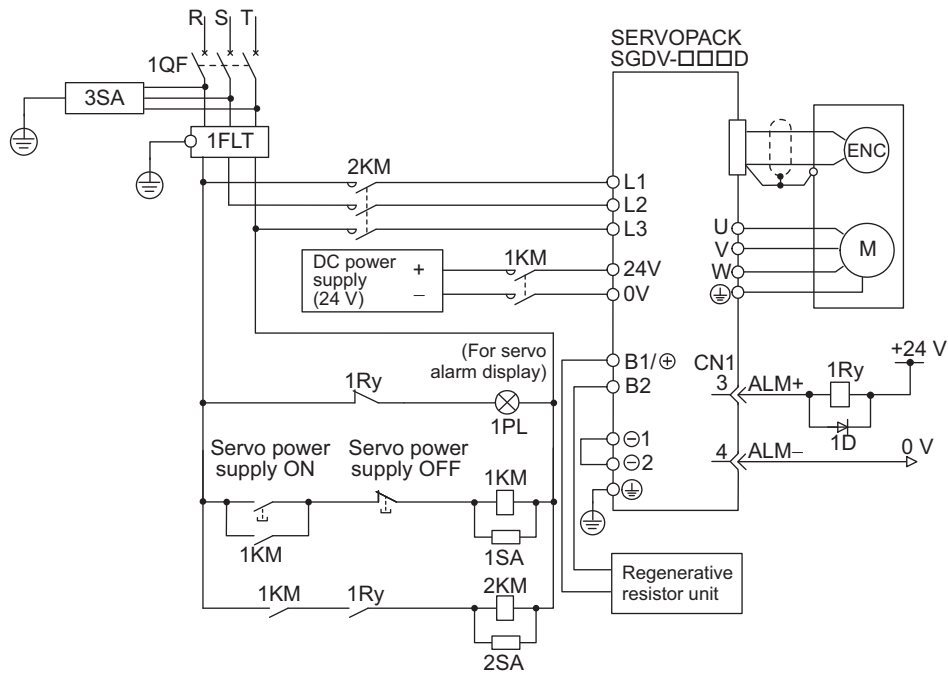

- |  |                     |
|--|---------------------|
| 1QF: Molded-case circuit breaker                   | 1PL: Indicator lamp |
| 1FLT: Noise filter                                 | 1SA: Surge absorber |
| 1KM: Magnetic contactor (for control power supply) | 2SA: Surge absorber |
| 2KM: Magnetic contactor (for main power supply)    | 3SA: Surge absorber |
| 1Ry: Relay   | 1D: Flywheel diode  |

#### (4) Power Supply Capacities and Power Losses

The following table gives the power capacities and power losses of the SERVOPACK.

Main Circuit Power Supply	Maximum Applicable Motor Capacity [kW]	SERVO-PACK Model SGD V-	Power Supply Capacity per SERVOPACK [kVA]	Output Current [Arms]	Main Circuit Power Loss [W]	Regenerative Resistor Power Loss [W]	Control Circuit Power Loss [W]	Total Power Loss [W]
Single-phase, 100-V	0.05	R70F	0.2	0.66	5.4	-	17	22.4
	0.1	R90F	0.3	0.91	7.8			24.8
	0.2	2R1F	0.7	2.1	14.4			31.4
	0.4	2R8F	1.4	2.8	25.6			42.6
Three-phase, 200-V	0.05	R70A	0.2	0.66	5.1	-	17	22.1
	0.1	R90A	0.3	0.91	7.3			24.3
	0.2	1R6A	0.6	1.6	13.5			30.5
	0.4	2R8A	1	2.8	24.0			41.0
	0.5	3R8A	1.4	3.8	20.1	8	17	45.1
	0.75	5R5A	1.6	5.5	43.8			68.8
	1.0	7R6A	2.3	7.6	53.6	10	22	78.6
	1.5	120A	3.2	11.6	65.8			97.8
	2.0	180A	4	18.5	111.9	16	22	149.9
	3.0	200A	5.9	19.6	113.8			161.4
	5.0	330A	7.5	32.9	263.7	36	27	326.7
	7.5	550A	14.6	54.7	357.8	(350) <sup>*1</sup>	33	390.8
Three-phase, 400-V	0.5	1R9D	1.1	1.9	24.6	14	21	59.6
	1.0	3R5D	2.3	3.5	46.1			81.1
	1.5	5R4D	3.5	5.4	71.3			106.3
	2.0	8R4D	4.5	8.4	77.9	28	25	130.9
	3.0	120D	7.1	11.9	108.7			161.7
	5.0	170D	11.7	16.5	161.1	36	24	221.1
	7.5	260D	14.4	25.7	218.6	(180) <sup>*2</sup>	27	245.6

\*1. For the optional JUSP-RA05-E regenerative resistor unit.

\*2. For the optional JUSP-RA18-E regenerative resistor unit

Note 1. SGD V-R70F, -R90F, -2R1F, -2R8F, -R70A, -R90A, -1R6A, and -2R8A SERVOPACKs do not have built-in regenerative resistors. If the regenerative energy exceeds the specified value, connect an external regenerative resistor (optional).

2. SGD V-550A and -260D SERVOPACKs do not have built-in regenerative resistors. Be sure to connect a regenerative resistor unit (optional) or an external regenerative resistor (optional). For selection details, refer to 3.7 *Regenerative Resistors Connections*.

3. Regenerative resistor power losses are allowable losses. Take the following action if the actual power loss exceeds the allowable power loss.

- Remove the lead or short bar that is short-circuiting the SERVOPACK main circuit terminal B2 and B3. (SGD V-3R8A, -5R5A, -7R6A, -120A, -180A, -200A, -330A, or 400-V class SERVOPACKs.)
- Install an external regenerative resistor (optional). For selection details, refer to 3.7 *Regenerative Resistors Connections*.



## (5) Molded-case Circuit Breaker and Fuse Capacities

The following table describes the molded-case circuit breaker and fuse capacities of the SERVOPACK.

Main Circuit Power Supply	Maximum Applicable Motor Capacity [kW]	SERVOPACK Model SGD V-	Power Supply Capacity per SERVOPACK [kVA]	Current Capacity		Inrush Current	
				Main Circuit [Arms]	Control Circuit [Arms]	Main Circuit [A0-p]	Control Circuit [A0-p]
Single-phase, 100-V	0.05	R70F	0.2	1.5	0.38	16.5	35
	0.1	R90F	0.3	2.5			
	0.2	2R1F	0.7	5			
	0.4	2R8F	1.4	10			
Three-phase, 200-V	0.05	R70A	0.2	1.0	0.2	33	70
	0.1	R90A	0.3	1.0			
	0.2	1R6A	0.6	2.0			
	0.4	2R8A	1	3.0			
	0.5	3R8A	1.4	3.0			
	0.75	5R5A	1.6	6.0			
	1.0	7R6A	2.3	6.0	0.25	33	
	1.5	120A	3.2	7.3			
	2.0	180A	4	9.7			
	3.0	200A	5.9	15			
	5.0	330A	7.5	25			
7.5	550A	14.6	37	0.3	65.5		
Three-phase, 400-V	0.5	1R9D	1.1	1.4	1.2	17	-
	1.0	3R5D	2.3	2.9			
	1.5	5R4D	3.5	4.3			
	2.0	8R4D	4.5	5.8	1.4	34	
	3.0	120D	7.1	8.6			
	5.0	170D	11.7	14.5			
	7.5	260D	14.4	21.7		1.5	

Note 1. To comply with the low voltage directive, connect a fuse to the input side. Select the fuse or molded-case circuit breaker for the input side from among models that are compliant with UL standards.

The table above also provides the net values of current capacity and inrush current. Select a fuse and a molded-case circuit breaker which meet the breaking characteristics shown below.

- Main circuit, control circuit: No breaking at three-times the current values of the table for 5 s.
- Inrush current: No breaking at the same current values of the table for 20 ms.

2. In accordance with UL standards, the following restrictions apply.

SERVOPACK Model SGD V-	Restrictions
180A, 200A	Available rated current for molded-case circuit breaker: 40 A or less
330A	<ul style="list-style-type: none"> <li>• Available rated current for non-time delay fuse: 70 A or less</li> <li>• Available rated current for time delay fuse: 40 A or less</li> <li>• Do not use single wires.</li> </ul>
550A	<ul style="list-style-type: none"> <li>• Available rated current for molded-case circuit breaker: 60 A or less</li> <li>• Available rated current for non-time delay fuse or time delay fuse: 60 A or less</li> </ul>
260D	<ul style="list-style-type: none"> <li>• Available rated current for molded-case circuit breaker: 60 A or less</li> <li>• Available rated current for non-time delay fuse: 60 A or less</li> <li>• Available rated current for time delay fuse: 35 A or less</li> </ul>

### 3.1.3 General Precautions for Wiring



#### IMPORTANT

Use a molded-case circuit breaker (1QF) or fuse to protect the main circuit.

- The SERVOPACK connects directly to a commercial power supply; it is not isolated through a transformer or other device.

Always use a molded-case circuit breaker (1QF) or fuse to protect the servo system from accidents involving different power system voltages or other accidents.

Install a ground fault detector.

- The SERVOPACK does not have a built-in protective circuit for grounding. To configure a safer system, install a ground fault detector against overloads and short-circuiting, or install a ground fault detector combined with a molded-case circuit breaker.

Do not turn power ON and OFF frequently.

- The power supply in the SERVOPACK contains a capacitor, which causes a high charging current to flow when power is turned ON. Frequently turning power ON and OFF will cause the main circuit elements in the SERVOPACK to deteriorate.

To ensure safe, stable application of the servo system, observe the following precautions when wiring.

Use the connecting cables specified in the *Σ-V Series Product Catalog* (KAEP S800000 42). Design and arrange the system so that each cable will be as short as possible.

- Use shielded twisted-pair wires or shielded multi-core twisted-pair wires for signal cables and linear scale connection cables.
- The maximum cable length is 3 m for the I/O signals, 20 m for the linear servomotor main circuit, 20 m for the serial converter unit, 15 m for the linear scale, and 15 m for the hall sensor.

Observe the following precautions when wiring the ground.

- Use a cable as thick as possible (at least 2.0 mm<sup>2</sup>).
- Grounding to a resistance of 100 Ω or less for SERVOPACKs with a power supply of 100 V or 200 V and 10 Ω or less for SERVOPACKs with a power supply of 400 V is recommended.
- Be sure to ground at only one point.
- Ground the linear servomotor directly if the linear servomotor is insulated from the machine.

The signal cable conductors are as thin as 0.2 mm<sup>2</sup> or 0.3 mm<sup>2</sup>. Do not impose excessive bending force or tension.

### 3.1.4 Using the SERVOPACK with Single-phase, 200-V Power Input

Some models of  $\Sigma$ -V series three-phase 200 V power input SERVOPACK can be used also with a single-phase 200 V power supply.

The following models use single-phase 200 V power input.  
SGDV-R70A, R90A, 1R6A, 2R8A, 5R5A

When using the SERVOPACK with single-phase, 200 V power input, set parameter Pn00B.2 to 1.

The SGDV-120AE5A008000 SERVOPACK has specifications for a single-phase, 200-V power supply, and so a single-phase, 200-V power supply can be used without changing the parameters.

#### (1) Parameter Setting

##### ■ Single-phase Power Input Selection

Parameter		Meaning	When Enabled	Classification
Pn00B	n.□0□□	Enables use of three-phase power supply for three-phase SERVOPACK. [factory setting]	After restart	Setup
	n.□1□□	Enables use of single-phase power supply for three-phase SERVOPACK.		



#### WARNING

- If single-phase 200 V is input to a SGDV-R70A, -R90A, -1R6A, -2R8A, or -5R5A SERVOPACK with a single-phase power input without changing the setting of Pn00B.2 to 1 (single-phase power input supported), a main circuit cable open phase alarm (A.F10) will be detected.
- The SERVOPACK models, SGDV-R70A, -R90A, -1R6A, -2R8A, and -5R5A, support single-phase 200 V power input. If a single-phase 200 V is input to the SERVOPACK models that do not support single-phase power input, the main circuit cable open phase alarm (A.F10) will be detected.
- When using a single-phase 200 V power supply, the SGDV-R70A, -R90A, -1R6A, -2R8A, or -5R5A SERVOPACK may not be able to produce the same linear servomotor force-speed characteristics as using a three-phase 200 V power input. Refer to the diagram of each linear servomotor force-speed characteristics in  *$\Sigma$ -V Series Product Catalog* (KAEP S800000 42).

#### (2) Main Circuit Power Input

Connect a single-phase 200 V power supply of the following specifications to L1 and L2 terminals.

The specifications of the power supplies other than the main circuit power supply are the same as for three-phase power supply input.

Terminal Symbols	Name	Model SGDV-□□□A	Rating
L1, L2	Main circuit power input terminals	R70, R90, 1R6, 2R8, 5R5	Single-phase 200 V to 230 V $^{+10\%}_{-15\%}$ , (50/60 Hz)
		120*2	Single-phase 220 V to 230 V $^{+10\%}_{-15\%}$ , (50/60 Hz)
L3*1	—	R70, R90, 1R6, 2R8, 5R5	None

\*1. Do not use L3 terminal.

\*2. The official model number is SGDV-120AE5A008000.

## (3) SERVOPACK Main Circuit Wire

Terminal Symbols	Name	Model SGD□V-□□□A					
		R70	R90	1R6	2R8	5R5	120*
L1, L2	Main circuit power input terminals	HIV1.25			HIV2.0		HIV3.5
L1C, L2C	Control power supply input terminals	HIV1.25					
U, V, W	Motor connection terminals	HIV1.25				HIV2.0	
B1/ ⊕, B2	External regenerative resistor connection terminals	HIV1.25					
⊕	Ground terminals	HIV2.0 or higher					

\* The official model name is SGD□V-120AE5A008000.

## (4) Wiring Example with Single-phase 200 V Power Supply Input

- SERVOPACK SGD□V-R70A, R90A, 1R6A, 2R8A, 5R5A, and 120AE5A008000 with Single-phase 200 V Input

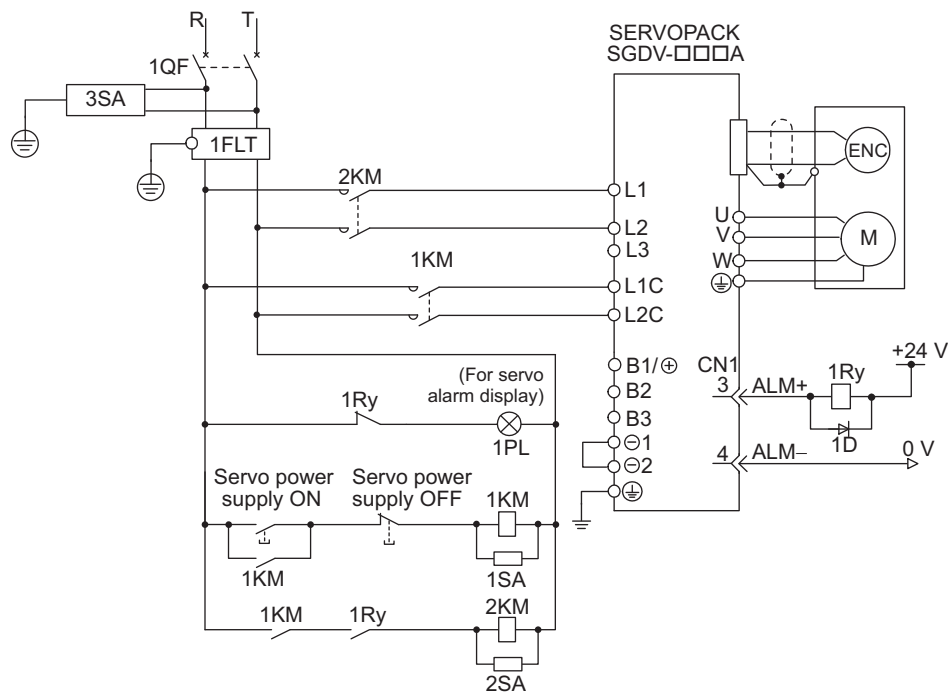

1QF: Molded-case circuit breaker  
 1FLT: Noise filter  
 1KM: Magnetic contactor (for control power supply)  
 2KM: Magnetic contactor (for main power supply)  
 1Ry: Relay

1PL: Indicator lamp  
 1SA: Surge absorber  
 2SA: Surge absorber  
 3SA: Surge absorber  
 1D: Flywheel diode

## (5) Power Supply Capacities and Power Losses

The following table shows SERVOPACK's power supply capacities and power losses when using a single-phase 200 V power supply.

Main Power Supply	Maximum Applicable Servomotor Capacity [kW]	SERVOPACK Model SGD V-	Power Supply Capacity per SERVOPACK [kVA]	Output Current [Arms]	Main Circuit Power Loss [W]	Regenerative Resistor Power Loss [W]	Control Circuit Power Loss [W]	Total Power Loss [W]
Single-phase, 200 V	0.05	R70A	0.2	0.66	5.2	-	17	22.2
	0.1	R90A	0.3	0.91	7.4			24.4
	0.2	1R6A	0.7	1.6	13.7			30.7
	0.4	2R8A	1.2	2.8	24.9			41.9
	0.75	5R5A	1.9	5.5	52.7	8	77.7	
	1.5	120A*	4	11.6	68.2	10	22	100.2

\* The official model name is SGD V-120AE5A008000.

Note 1. SGD V-R70A, R90A, 1R6A, and 2R8A SERVOPACKs do not have built-in regenerative resistors. If the regenerative energy exceeds the specified value, connect an external regenerative resistor.

2. Regenerative resistor power losses are allowable losses. Take the following action if the actual power losses exceeds the allowable power loss.

- Remove the wire connecting terminals B2 and B3 of the SERVOPACK main circuit terminals or remove the short bar (SGDV-5R5A, 120A).
- Install an external regenerative resistor between the external regenerative resistor connection terminals B1/ ⊕ and B2

3. External regenerative resistors are options.

## (6) Molded-case Circuit Breaker and Fuse Capacities

The following table shows the molded-case circuit breaker and fuse capacities when using single-phase 200 V power supply.

Main Power Supply	Maximum Applicable Servomotor Capacity [kW]	SERVOPACK Model SGD V-	Power Supply Capacity per SERVOPACK [kVA]	Current Capacity		Inrush Current	
				Main Circuit [Arms]	Control Circuit [Arms]	Main Circuit [A0-p]	Control Circuit [A0-p]
Single-phase, 200 V	0.05	R70A	0.2	2	0.2	33	70
	0.1	R90A	0.3	2			
	0.2	1R6A	0.7	3			
	0.4	2R8A	1.2	5			
	0.75	5R5A	1.9	9			
	1.5	120A*	4	16	0.25	33	

\* The official model name is SGD V-120AE5A008000.

Note 1. To comply with the low voltage directive, connect a fuse to the input side. Select the fuse for the input side from among models that are compliant with UL standards.

The table above also provides the net values of current capacity and inrush current. Select a fuse and a molded-case circuit breaker which meet the breaking characteristics shown below.

- Main circuit, control circuit: No breaking at three times the current values shown in the table for 5 s.
- Inrush current: No breaking at the current values shown in the table for 20 ms.

2. The following usage restrictions apply to the UL installation certification conditions for the SGD V-120AE5A008000 SERVOPACK.

Available rated current for molded-case circuit breaker: 40 A or less.

### 3.1.5 Using the SERVOPACK with a DC Power Input

#### (1) Parameter Settings

When using the SERVOPACK with a DC power input, set parameter Pn001.2 to 1.

Parameter	Meaning	When Enabled	Classification
Pn001	n.□0□□	After restart	Setup
	n.□1□□		

Observe the following precautions when using a DC power input.

 WARNING
<ul style="list-style-type: none"> <li>• Either AC or DC power can be input to the 200 V, 400 V SERVOPACKs. Always set Pn001.2 to 1 to specify a DC power input before inputting DC power. Only AC power can be input to the 100 V SERVOPACKs. If DC power is input without changing the parameter setting, the SERVOPACK's internal elements will burn and may cause fire or equipment damage.</li> <li>• With a DC power input, time is required to discharge electricity after the main power supply is turned OFF. A high residual voltage may remain in the SERVOPACK after the power supply is turned OFF. Be careful not to get an electric shock.</li> <li>• Install fuses on the wires if DC power is used.</li> <li>• Linear servomotor returns a regenerated energy to the power supply. The SERVOPACK that can use a DC power supply is not capable of processing the regenerated energy. Provide measures to process the regenerated energy on the power supply.</li> <li>• With a DC power input, connect an external inrush current limit circuit. Failure to observe this caution may result in damage to the product.</li> </ul>

#### (2) DC Power Supply Input Terminals for the Main and Control Circuits

- Three-phase, 200-V SGD□V-□□□A (□□□ = R70, R90, 1R6, 2R8, 3R8, 5R5, 7R6, 120, 180, 200, 330)

Terminal Symbols	Name	Specification
B1/ ⊕	Main circuit plus terminal	270 to 320 VDC
⊖ 2	Main circuit minus terminal	0 VDC
L1C, L2C	Control power supply input terminal	200 to 230 VAC

- Three-phase, 200-V SGD□V-□□□A (□□□ = 550)

Terminal Symbols	Name	Specification
B1/ ⊕	Main circuit plus terminal	270 to 320 VDC
⊖	Main circuit minus terminal	0 VDC
L1C, L2C	Control power supply input terminal	200 to 230 VAC

- Three-phase, 400-V SGD□V-□□□D (□□□ = 1R9, 3R5, 5R4, 8R4, 120, 170, 260)

Terminal Symbols	Name	Specification
B1/ ⊕	Main circuit plus terminal	513 to 648 VDC
⊖ 2	Main circuit minus terminal	0 VDC
24 V, 0 V	Control power supply input terminal	24 VDC (±15%)

(3) Wiring Examples with DC Power Supply Input

■ SERVOPACK SGDV-□□□A with 200-V Power Supply Input

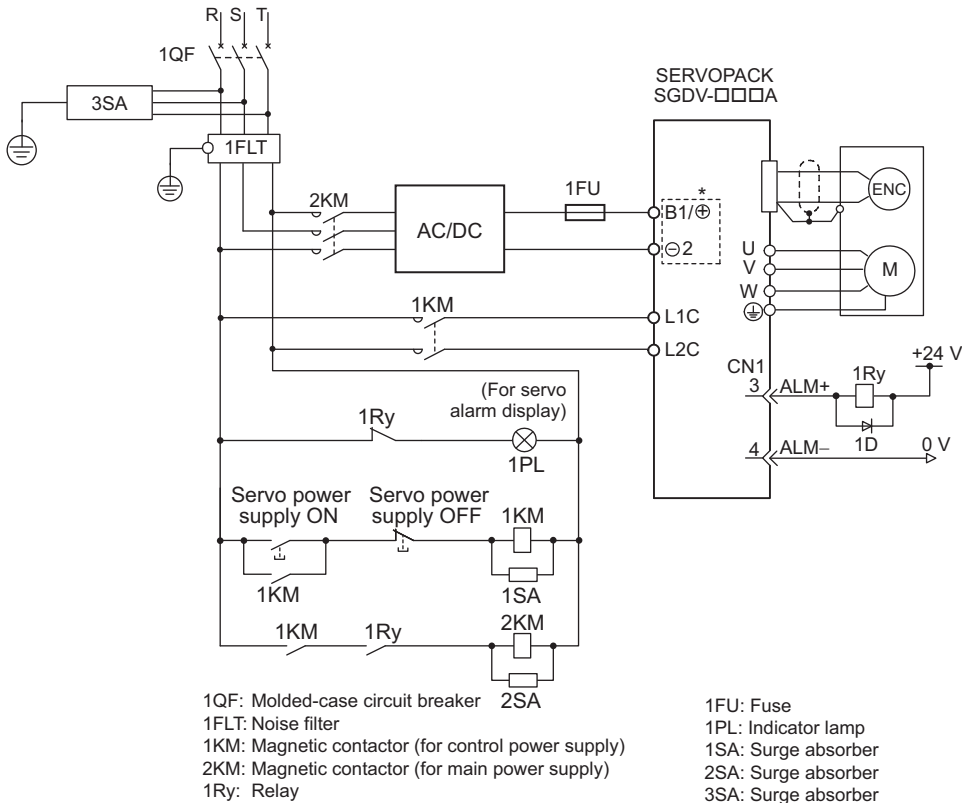

\* Terminal names differ depending on the model of SERVOPACK. Refer to (2) DC Power Supply Input Terminals for the Main and Control Circuits.

■ SERVOPACK SGDV-□□□D with 400-V Power Supply Input

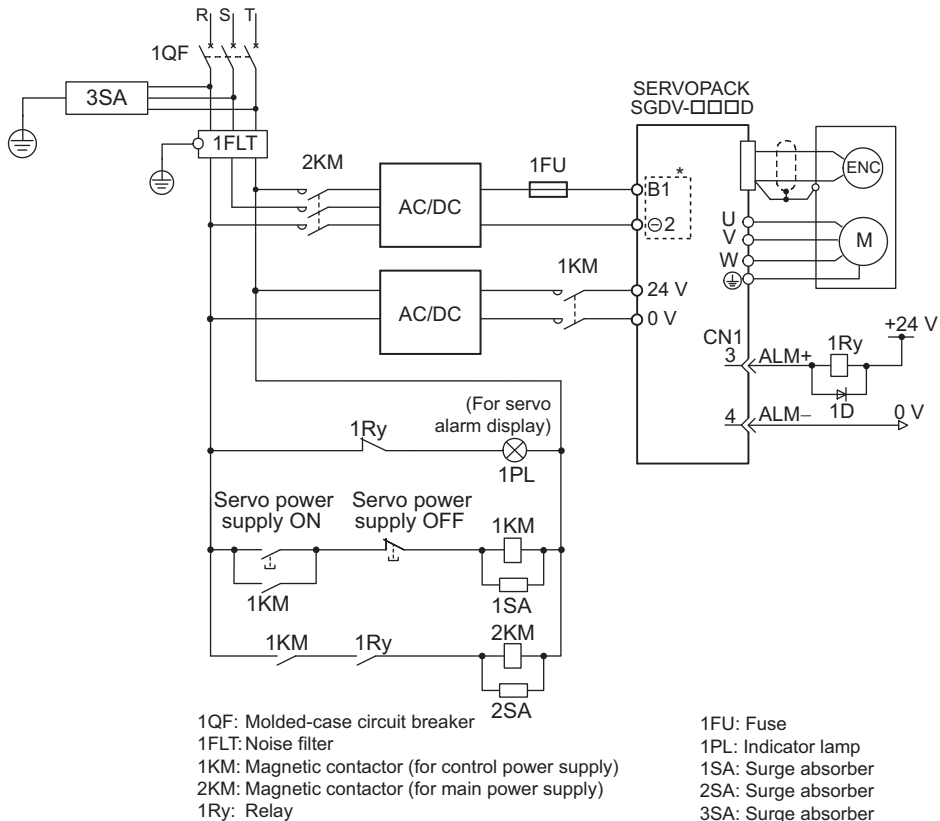

\* Terminal names differ depending on the model of SERVOPACK. Refer to (2) DC Power Supply Input Terminals for the Main and Control Circuits.

### 3.1.6 Using More Than One SERVOPACK

This section shows an example of the wiring when more than one SERVOPACK is used and the precautions.

#### (1) Wiring Example

Connect the alarm output (ALM) terminals for the three SERVOPACKs in series to enable alarm detection relay 1Ry to operate.

When the alarm occurs, the ALM output signal transistor is turned OFF.

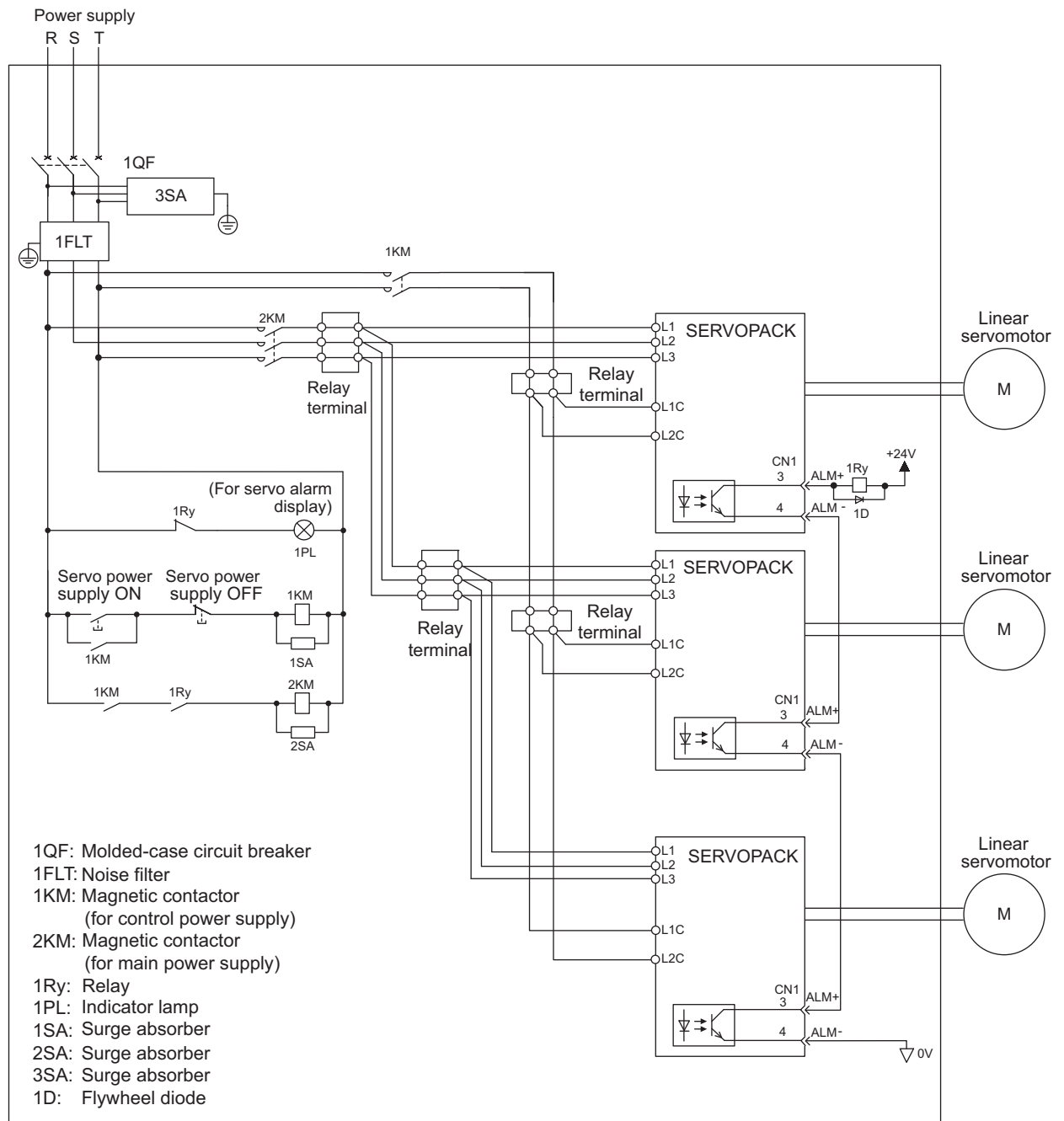

#### (2) Precautions

Multiple servos can share a single molded-case circuit breaker (1QF) and a noise filter. Always select a 1QF and a noise filter that has enough capacity for the total power capacity (load conditions) of those servos.



## 3.2 I/O Signal Connections

This section describes the names and functions of I/O signals (CN1). Also, connection examples by control method are shown.

### 3.2.1 I/O Signal (CN1) Names and Functions

The following table shows the names and functions of I/O signals (CN1).

#### (1) Input Signals

Signal	Pin No.	Name	Function	Reference Section
/SI3	9	Command Option Module input 3	Connects the external input signal* used in the Command Option Module.	–
P-OT	7	Forward run prohibited	Overtravel prohibited: Stops linear servomotor when movable part travels beyond the allowable range of motion.	4.2.2
N-OT	8	Reverse run prohibited		
/SI4	10	Command Option Module input 4	Connects the external input signal* used in the Command Option Module.	–
/SI5	11	Command Option Module input 5		
/SI6	12	Command Option Module input 6		
+24VIN	6	Control power supply input for sequence signal	Control power supply input for sequence signals. Allowable voltage fluctuation range: 11 to 25 V Note: The +24-V power supply is not included.	3.4.1
/SI0	13	General-purpose input	Connects the external input signal* used in the Command Option Module.	–

\* Refer to the manual of the connected Command Option Module for information on how to allocate and use I/O signals.

Note 1. The functions allocated to /SI3, P-OT, N-OT, /SI4, /SI5, and /SI6 input signals can be changed by using the parameters. Refer to 3.3.1 *Input Signal Allocations*.

- If the Forward run prohibited/Reverse run prohibited function is used, the software can be used to stop the SERVOPACK. If the application does not satisfy the safety requirements, add an external circuit for safety reasons as required.

#### (2) Output Signals

Signal	Pin No.	Name	Function	Reference Section
ALM+	3	Servo alarm output	Turns OFF when an error is detected.	–
ALM-	4			
/BK+ (/SO1+)	1	Brake output	Controls the brake. The brake is released when the signal turns ON. Allocation can be changed to general-purpose output signals (/SO1+, /SO1-).	4.2.3
/BK- (/SO1-)	2			
/SO2+	23	General-purpose output	General-purpose output signals Note: Set the parameters to allocate functions.	–
/SO2-	24			
/SO3+	25			
/SO3-	26			
SG	16	Signal ground	0 V of control circuit	–
FG	Connector shell	Frame ground	Connected to frame ground if the shield wire of the I/O signal cable is connected to the connector shell.	–

Note: For more information on the allocation of /SO1, /SO2, and /SO3, refer to 3.3.2 *Output Signal Allocation*.

### 3.2.2 Safety Function Signal (CN8) Names and Functions

The following table shows the terminal layout of safety function signals (CN8).

Signal	Pin No.	Name	Function
/HWBB1+	4	Hard wire base block input 1	Hard wire base block input Base Block (motor current off) when OFF
/HWBB1-	3		
/HWBB2+	6	Hard wire base block input 2	
/HWBB2-	5		
EDM1+	8	Monitored circuit status output 1	ON when the /HWBB1 and the /HWBB2 signals are input and the SERVOPACK enters a base block state.
EDM1-	7		
-	1*	-	-
-	2*	-	-

\* Do not use pins 1 and 2. They are connected to the internal circuits.

### 3.2.3 Example of I/O Signal Connections

The following diagram shows a typical connection example.

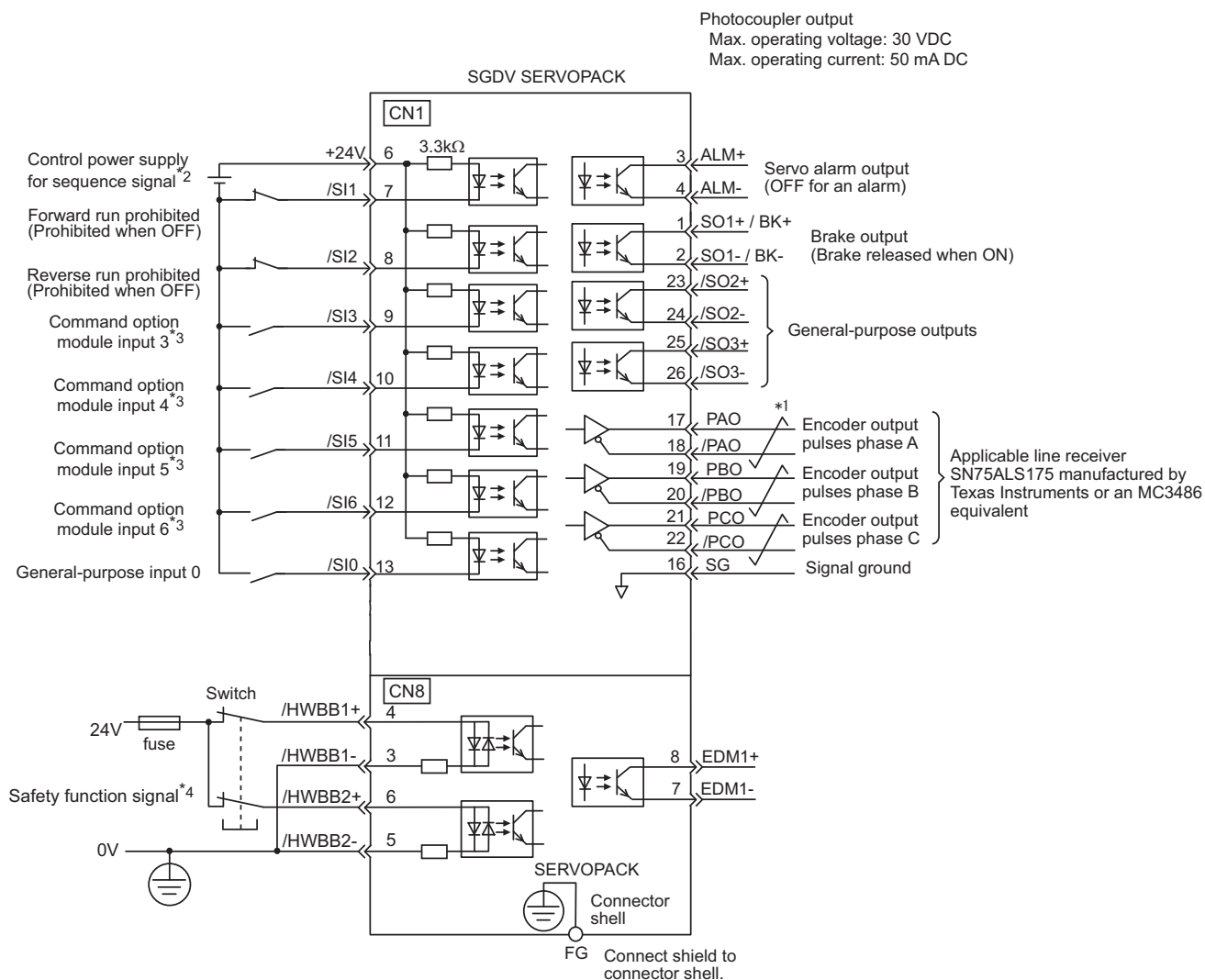

\*1. represents twisted-pair wires.

\*2. The 24 VDC power supply is not included. Use a power supply with double insulation or reinforced insulation.

\*3. For details, refer to the manual of the connected Command Option Module.

\*4. To turn the servomotor power ON, a safety device must be connected and the wiring to activate the safety function must be done. When not using the safety function, use the SERVOPACK with the plug (JZSP-CVH05-E, provided as an accessory) inserted into the CN8.

Note: The functions allocated to the input signals /SI3, P-OT, N-OT, /SI0, /SI4, /SI5, and /SI6 and the output signals /SO1, /SO2, and /SO3 can be changed by using the parameters. Refer to 3.3.1 *Input Signal Allocations* and 3.3.2 *Output Signal Allocation*.

### 3.3 I/O Signal Allocations

This section describes the I/O signal allocations.

#### 3.3.1 Input Signal Allocations

Input signals are allocated as shown in the following table.

Refer to the *Interpreting the Input Signal Allocation Tables* and change the allocations accordingly.

<Interpreting the Input Signal Allocation Tables>

Input Signal Names and Parameters	Validity Level	Input Signal	CN1 Pin Numbers								Connection Not Required (SERVOPACK judges the connection)	
			13	7	8	9	10	11	12	Always ON	Always OFF	
Forward Run Prohibited <b>Pn50A.3</b>	H	P-OT	0	<b>1</b>	2	3	4	5	6	7	8	
	L	/P-OT	9	A	B	C	D	E	F			

Input Signal Names and Parameters	Validity Level	Input Signal	CN1 Pin Numbers							Connection Not Required (SERVOPACK judges the connection)	
			13	7	8	9	10	11	12	Always ON	Always OFF
Forward Run Prohibited <b>Pn50A.3</b>	H	P-OT	0	1	2	3	4	5	6	7	8
	L	/P-OT	9	A	B	C	D	E	F		
Reverse Run Prohibited <b>Pn50B.0</b>	H	N-OT	0	1	2	3	4	5	6	7	8
	L	/N-OT	0	A	B	C	D	E	F		
Forward External Force Limit <b>Pn50B.2</b>	L	/P-CL	0	1	2	3	4	5	6	7	8
	H	P-CL	9	A	B	C	D	E	F		
Reserve External Force Limit <b>Pn50B.3</b>	L	/N-CL	0	1	2	3	4	5	6	7	8
	H	N-CL	9	A	B	C	D	E	F		
Command Option Module Input 3 <sup>*1</sup> <b>Pn511.0</b>	L	/SI3	0	1	2	3	4	5	6	7	8
	H	SI3	9	A	B	C	D	E	F		
Command Option Module Input 4 <sup>*1</sup> <b>Pn511.1</b>	L	/SI4	*2	*2	*2	*2	4	5	6	7	8
	H	SI4	*2	*2	*2	*2	D	E	F		
Command Option Module Input 5 <sup>*1</sup> <b>Pn511.2</b>	L	/SI5	*2	*2	*2	*2	4	5	6	7	8
	H	SI5	*2	*2	*2	*2	D	E	F		
Command Option Module Input 6 <sup>*1</sup> <b>Pn511.3</b>	L	/SI6	*2	*2	*2	*2	4	5	6	7	8
	H	SI6	*2	*2	*2	*2	D	E	F		

\*1. For details, refer to the manual of the connected Command Option Module.

\*2. Allocation is not possible.



### IMPORTANT

- This signals not detected are considered as "Invalid".
- Inverting the polarity of the Forward run prohibited and Reverse run prohibited signals from the default setting, will prevent the overtravel function from working in case of failure such as their signal line disconnections. If this setting is absolutely necessary, check the operation and confirm that there are no safety problems.
- If two or more signals are allocated to the same input circuit, a signal is output with OR logic and circuit input signal level will be valid for all allocated signals.

### 3.3.2 Output Signal Allocation

Output signals are allocated as shown in the following table.

Refer to the *Interpreting the Output Signal Allocation Tables* and change the allocations accordingly.

<Interpreting the Output Signal Allocation Tables>

The parameter set values to be used are shown. Signals are allocated to CN1 pins according to the selected set values. Values in cells in bold lines are the factory settings.

Output Signal Names and Parameters	Output Signal	CN1 Pin Numbers			Invalid (not use)
		1/(2)	23/(24)	25/(26)	
Positioning Completion <b>Pn50E.0</b>	/COIN	1	2	3	0

Output Signal Names and Parameters	Output Signal	CN1 Pin Numbers			Invalid (not use)
		1/ (2)	23/ (24)	25/ (26)	
Positioning Completion <b>Pn50E.0</b>	/COIN	1	2	3	0
Speed Coincidence Detection <b>Pn50E.1</b>	/V-CMP	1	2	3	0
Movement Detection <b>Pn50E.2</b>	/TGON	1	2	3	0
Servo Ready <b>Pn50E.3</b>	/S-RDY	1	2	3	0
Force Limit Detection <b>Pn50F.0</b>	/CLT	1	2	3	0
Speed Limit Detection <b>Pn50F.1</b>	/VLT	1	2	3	0
Brake <b>Pn50F.2</b>	/BK	1	2	3	0
Warning <b>Pn50F.3</b>	/WARN	1	2	3	0
Near <b>Pn510.0</b>	/NEAR	1	2	3	0
Output signal polarity inversion <b>Pn512.0=1</b>	Polarity inversion of CN1-1(2)			0 (Not invert at factory setting)	
Output signal polarity inversion <b>Pn512.1=1</b>	Polarity inversion of CN1-23(24)				
Output signal polarity inversion <b>Pn512.2=1</b>	Polarity inversion of CN1-25(26)				



**IMPORTANT**

- The signals not detected are considered as “Invalid.”
- Inverting the polarity of the brake signal (/BK), i.e. positive logic, will prevent the holding brake from working in case of its signal line disconnection. If this setting is absolutely necessary, check the operation and confirm that there are no safety problems.
- If two or more signals are allocated to the same output circuit, a signal is output with OR logic circuit.

### 3.4 Connection to Host Controller

This section shows examples of SERVOPACK I/O signal connection to the host controller.

#### 3.4.1 Sequence Input Circuits

##### (1) Photocoupler Input Circuit

CN1 connector terminals 6 to 13 are explained below.

The sequence input circuit interface connects through a relay or open-collector transistor circuit. Select a low-current relay if a relay is used. Otherwise, a faulty contact will result.

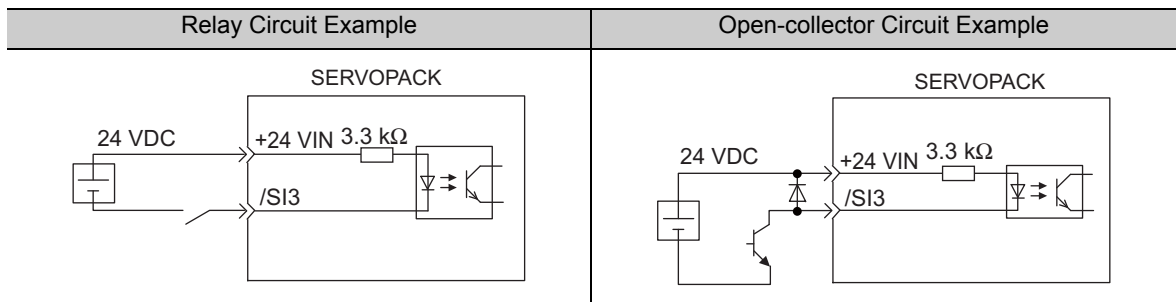

Note: The 24 VDC external power supply capacity must be 50 mA minimum.

The SERVOPACK's I/O circuit uses bidirectional photocoupler. Select either the sink circuit or the source circuit according to the specifications required for each machine.

- Note:
- The connection example in section 3.2.3 shows the connection using the sink circuit.
  - The polarity for turning the input signal ON or OFF differs between the sink circuit and the source circuit.

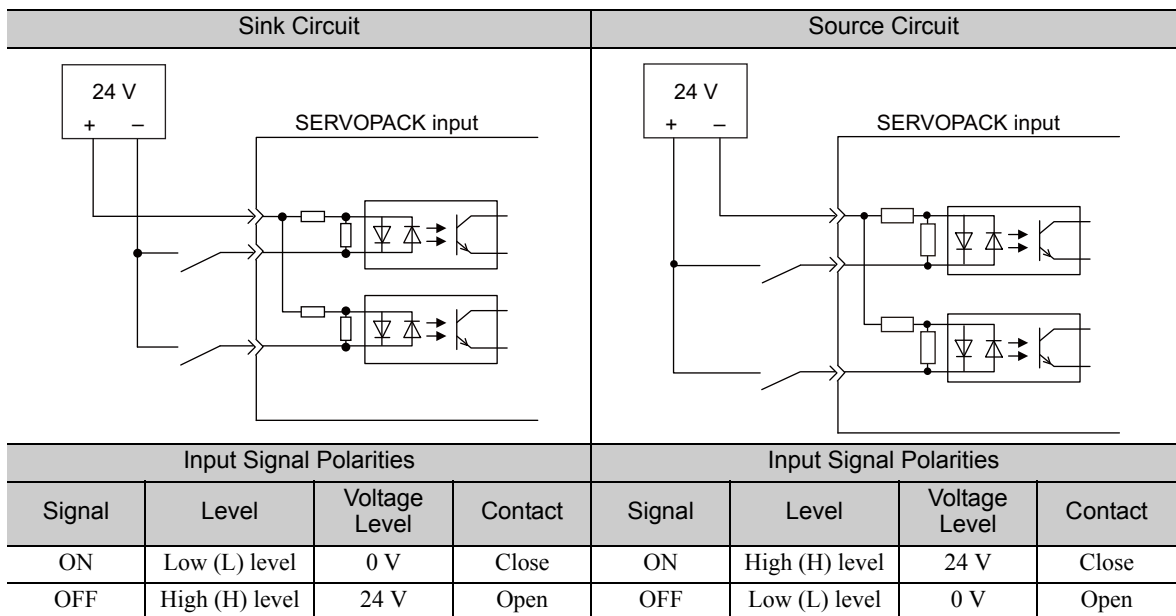

## (2) Safety Input Circuit

As for wiring input signals for safety function, input signals make common 0 V. It is necessary to make an input signal redundant.

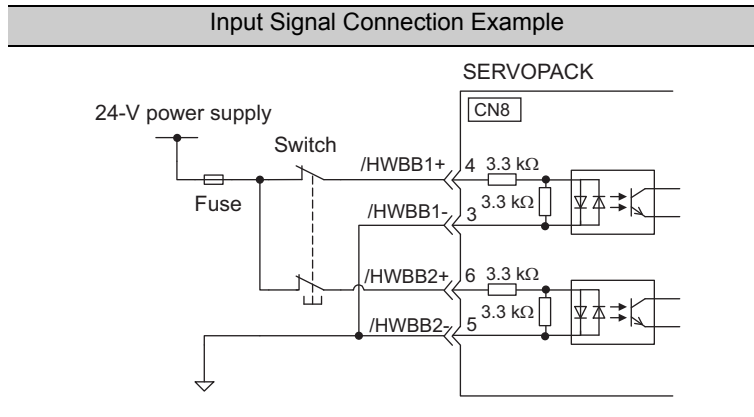



### 3.4.2 Sequence Output Circuits

The following diagrams show examples of how output circuits can be connected the SERVOPACK.

 <b>IMPORTANT</b>	<p>Incorrect wiring or incorrect voltage application to the output circuit may cause short-circuit.</p> <p>The above failures will prevent the holding brake from working, which may damage the machine or cause an accident resulting in death or injury.</p>
---	--

#### (1) Photocoupler Output Circuit

Photocoupler output circuits are used for servo alarm (ALM), servo ready (/S-RDY), and other sequence output signal circuits. Connect a photocoupler output circuit through a relay or line receiver circuit.

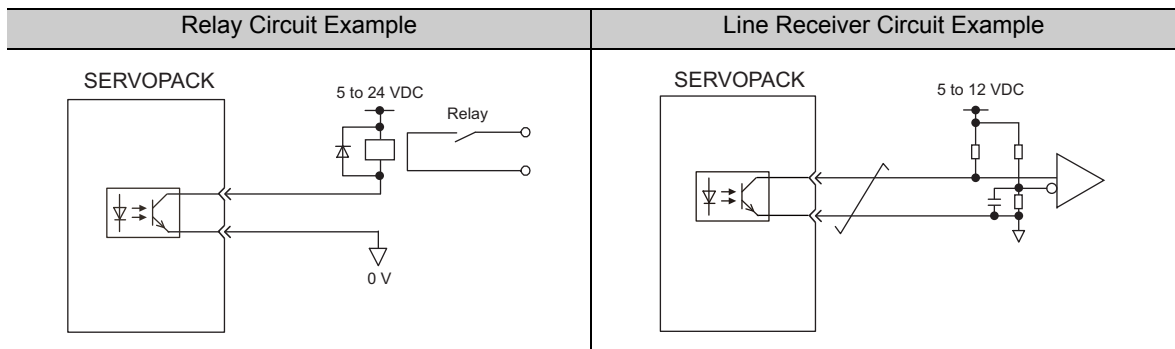

Note: The maximum allowable voltage and current capacities for photocoupler output circuits are as follows.

- Voltage: 30 VDC
- Current: 5 to 50 mA DC

#### (2) Line Driver Output Circuit

CN1 connector terminals, 17-18 (phase-A signal), 19-20 (phase-B signal), and 21-22 (phase-C signal) are explained below.

Linear scale serial data converted to two-phase (phases A and B) pulse output signals (PAO, /PAO, PBO, /PBO) and origin pulse signals (PCO, /PCO) are output via line-driver output circuits. Connect the line-driver output circuit through a line receiver circuit at the host controller.

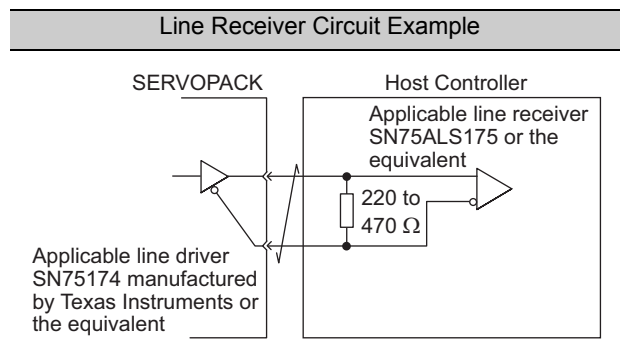

### (3) Safety Output Circuit

External device monitor (EDM1), an output signal of safety function, is explained below.

#### ■ Connection Example

The following figure shows a connection example for the EDM1 output signal.

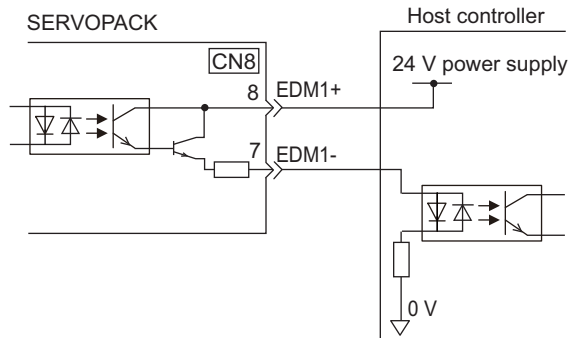

#### ■ Specifications

Type	Signal Name	Pin No.	Input Status	Meaning
Output	EDM1	CN8-8 CN8-7	ON	The /HWBB1 signal and /HWBB2 signal are both operating normally.
			OFF	Both the /HWBB1 signal and /HWBB2 signal are not operating normally or either of the two is not operating normally.

Electrical characteristics of EDM1 signal are as follows.

Items	Characteristic	Remarks
Maximum Allowable Voltage	30 VDC	–
Maximum Current	50 mADC	–
Maximum Voltage Drop at ON	1.0 V	Voltage between EDM1+ to EDM1- at current is 50 mA.
Maximum Delay Time	20 ms	Time from change of /HWBB1, /HWBB2 to change of EDM1

### 3.5 Wiring Communications Using Command Option Modules

The following diagram shows an example of connections between a host controller and a SERVOPACK using communications with Command Option Modules.

Connect the connector of the communications cable to the Command Option Module.

For details, refer to the manual of the connected Command Option Module.

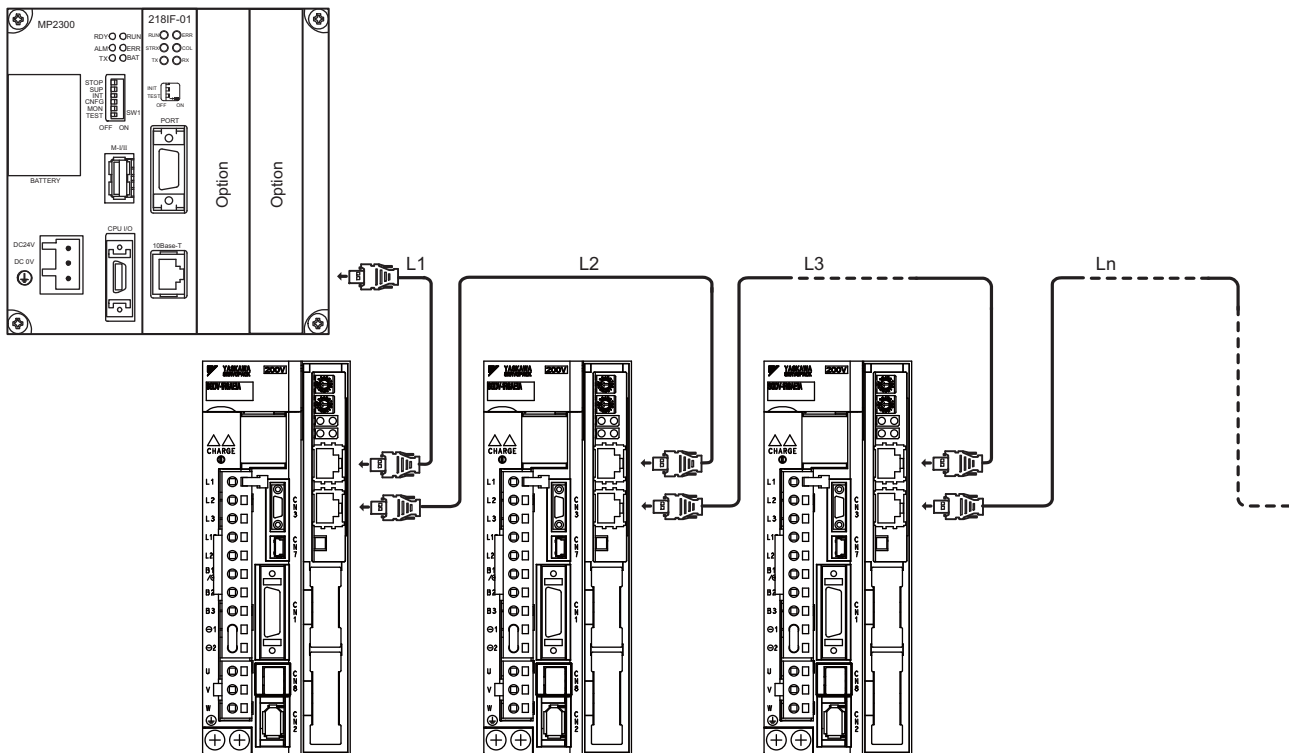

## 3.6 Linear Scale Connections

This section describes the connection example of output signals between linear scale, SERVOPACK and host controller.

CN2 linear scale connector terminal layout is also described.

### 3.6.1 Linear Scale Signal (CN2) Names and Functions

The following table shows the names and functions of the linear scale signals (CN2).

Signal	Pin No.	Function
PG 5 V	1	Linear scale power supply +5 V
PG 0 V	2	Linear scale power supply 0 V
PS	5	Serial data (+)
/PS	6	Serial data (-)
Shield	Shell	-
-	3*	-
-	4*	-

\* Do not use the pins 3 and 4. They are connected to internal circuit.

### 3.6.2 Connection Example of a Linear Scale

The following diagrams show examples of connecting linear scale.

#### (1) Linear Scale Made by Heidenhain

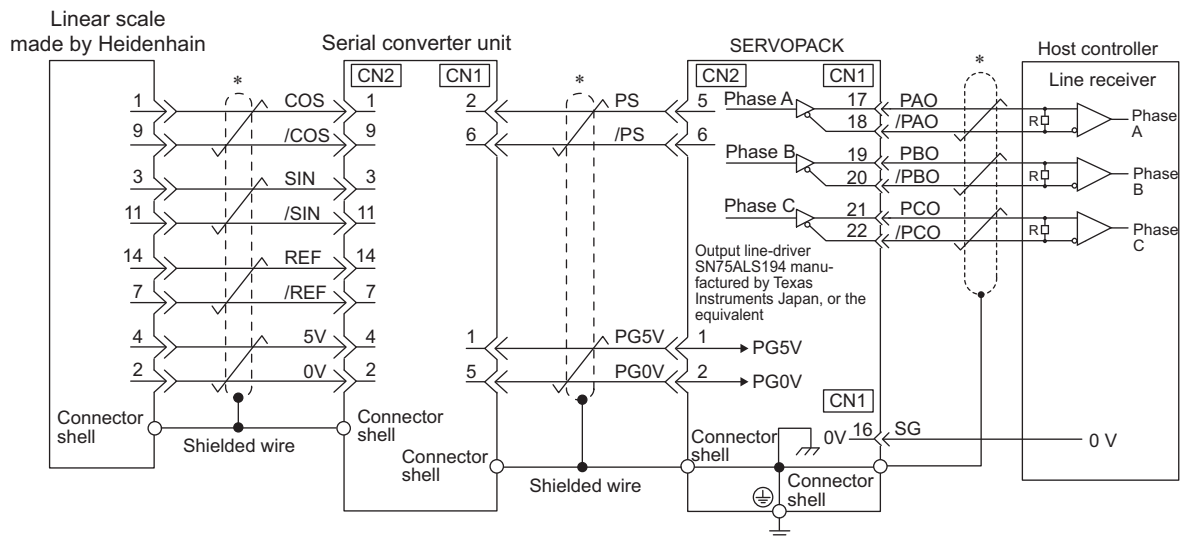

(2) Linear Scale Made by Renishaw

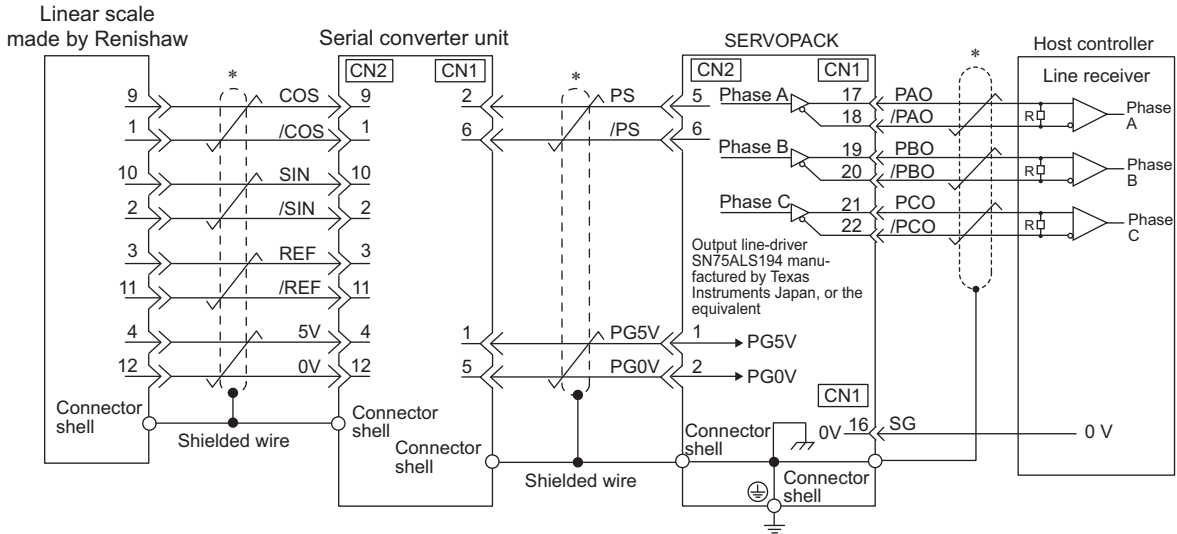

(3) Absolute Linear Scale Made by Mitutoyo

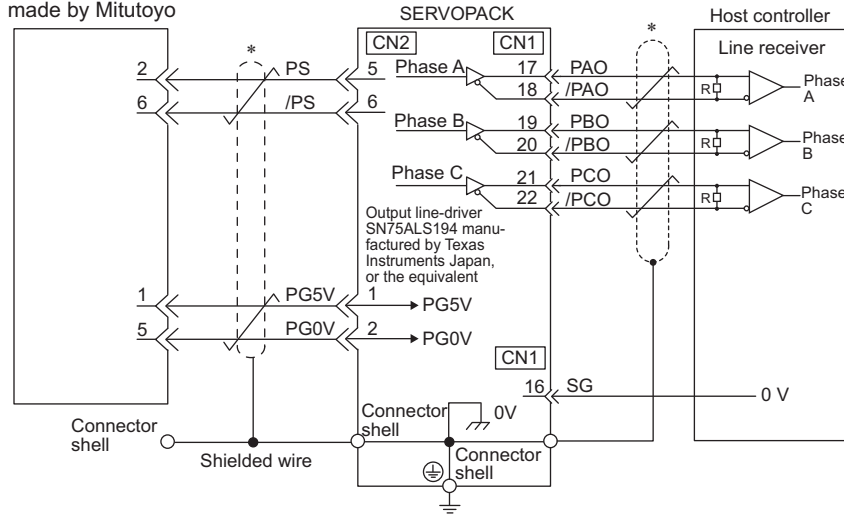

(4) Absolute Linear Scale Made by Magescale Co., Ltd.

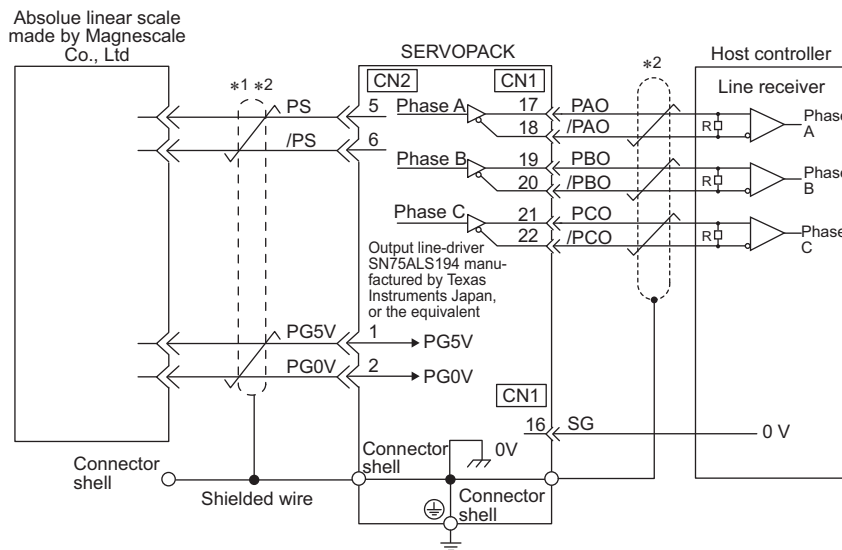

Applicable line receiver: SN75ALS175 or MC3486 manufactured by Texas Instruments Japan, or the equivalent

R (terminating resistance): 220 to 470 Ω

\*1. For the cable to connect the linear scale to the SERVOPACK, use the cable (model: SR77-□□□□□□□□□□) made by Magescale Co., Ltd.

\*2.  : represents twisted-pair wires.

3.6.3 Serial Converter Unit Specifications

The following table shows the specifications of serial converter unit.

	Items	Model JZDP-D00□-□□□E	Model JZDP-G00□-□□□E
Electrical Characteristics	Power Supply Voltage	+5.0V±5%, ripple content 5% max.	
	Current Consumption *1	120 mA Typ. 350 mA max.	
	Signal Resolution	Input 2-phase sine wave: 1/256 pitch	Input 2-phase sine wave: 1/4096 pitch
	Max. Response Frequency	250 kHz	100 kHz
	Analog Input Signals *2 (cos, sin, Ref)	Differential input amplitude: 0.4 V to 1.2 V Input signal level: 1.5 V to 3.5 V	
	Hall Sensor Input Signal	CMOS level	
	Output Signal *3	Position data, hall sensor information, alarms	
	Output Method	Serial data communications	
Mechanical Characteristics	Output Circuit	Balanced type transceiver (SN75LBC176 or the equivalent), internal terminating resistance: 120 Ω	
	Approx. Mass	150 g	
	Vibration Resistance	98 m/s <sup>2</sup> max. (10 to 2500 Hz) in three directions	
	Shock Resistance	980 m/s <sup>2</sup> , (11 ms) two times in three directions	

Items		Model JZDP-D00□-□□□E	Model JZDP-G00□-□□□E
Environmental Conditions	Surrounding Air Temperature	0 °C to 55 °C	
	Storage Temperature	-20 °C to +80 °C	
	Humidity	20 % to 90 %RH (without condensation)	

- \*1. The current consumption of the linear scale and the hall sensor is not included in this value.  
The current consumption of the linear scale and the hall sensor must be taken into consideration for the current capacity of host controller that supplies the power. (Hall sensor current consumption: Approx. 40 mA)
- \*2. Input a value within the specified range. Otherwise, incorrect position information is output, and the device may be damaged.
- \*3. The transmission is enabled 100 to 300 ms after the power turns ON.

## 3.7 Regenerative Resistors Connections

If the ability to absorb regenerative energy is insufficient, connect an external regenerative resistor in the following manner and set the regenerative resistor capacity in Pn600. As for precautions on selecting a regenerative resistor and its specifications, refer to  *$\Sigma$ -V series Product Catalog* (KAEP S800000 42).

### ! WARNING

- Be sure to connect the regenerative resistor correctly.  
Failure to observe this warning may result in fire or damage to the product.

### 3.7.1 Connecting Regenerative Resistors

The following instructions show how to connect the regenerative resistors and SERVOPACKs.

#### (1) SERVOPACKs: Model SGD V-R70F, R90F, 2R1F, 2R8F, R70A, R90A, 1R6A, 2R8A

Install an external regenerative resistor between the B1/⊕ and B2 terminals. Make the settings for the regenerative resistor after it is connected. For information setting the regenerative resistor, refer to 3.7.2 *Setting Regenerative Resistor Capacity*.

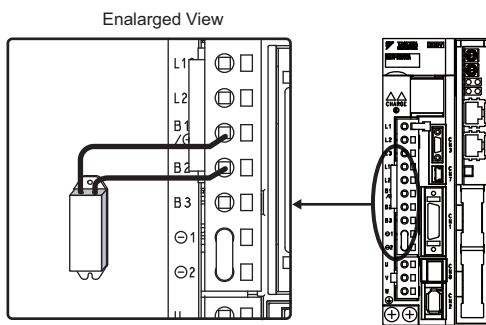

#### (2) SERVOPACKs: Model SGD V-3R8A, 5R5A, 7R6A, 120A, 180A, 200A, 330A, 1R9D, 3R5D, 5R4D, 8R4D, 120D, 170D

Disconnect the wiring between the SERVOPACK's B2 and B3 terminals and connect an external regenerative resistor between the B1/⊕ and B2 terminals. Make the settings for the regenerative resistor after it is connected. For information setting the regenerative resistor, refer to 3.7.2 *Setting Regenerative Resistor Capacity*.

Note: Be sure to take out the lead wire between the B2 and B3 terminals.

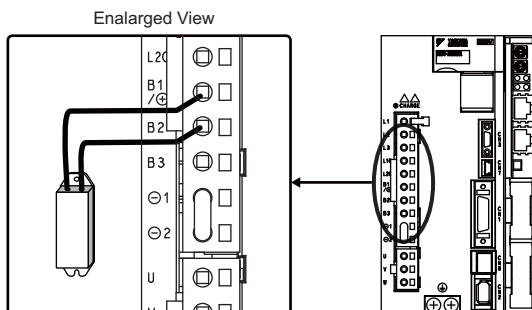



(3) SERVOPACKs: Model SGDV-550A, 260D

No built-in regenerative resistor is provided, so an external regenerative resistor unit is required. The regenerative resistor units are as follows:

Main Circuit Power Supply	SERVOPACK Model SGDV-	Applicable Regenerative Resistor Unit	Resistance ( $\Omega$ )	Specifications
Three-phase 200 V	550A	JUSP-RA05-E	3.13	Eight 25 $\Omega$ (220 W) resistors are connected in parallel.
Three-phase 400 V	260D	JUSP-RA18-E	18	Two series of two 18 $\Omega$ (220 W) resistors each are connected in parallel.

Connect a regenerative resistor unit between the B1 and B2 terminals.

When using a regenerative resistor unit, use the factory setting for Pn600. If a non-Yaskawa regenerative resistor is used, make the setting for Pn600.

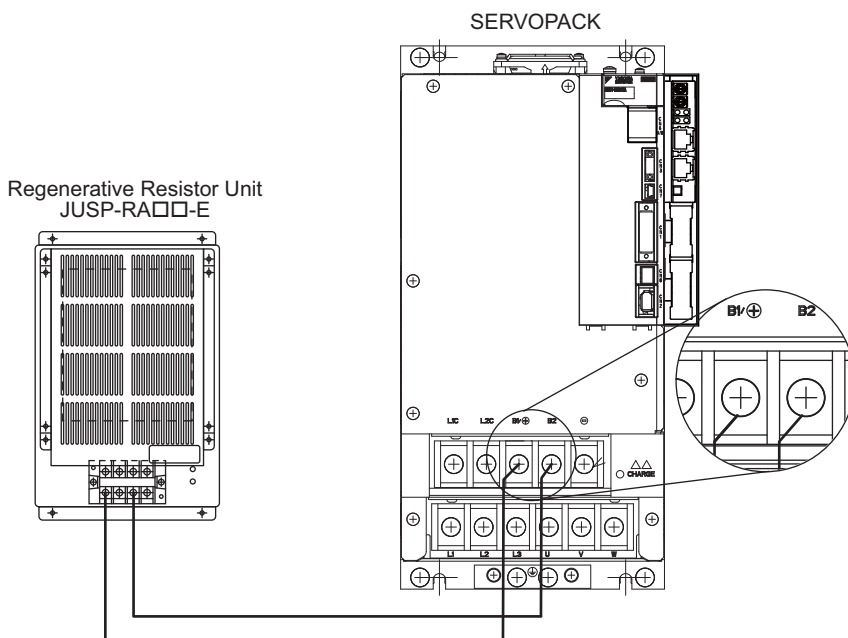

### 3.7.2 Setting Regenerative Resistor Capacity

When an external regenerative resistor is connected, make sure to set the regenerative resistor capacity using the parameter Pn600.

 <b>WARNING</b>
<ul style="list-style-type: none"> <li>If parameter Pn600 is set to 0 while an external regenerative resistor is connected, the generative overload alarm (A.320) may not be detected. If the generative overload alarm (A.320) is not detected correctly, the external regenerative resistor may be damaged and an injury or fire may result.</li> </ul>

Pn600	Regenerative Resistor Capacity				Speed	Position	Force	Classification
	Setting Range	Unit	Factory Setting	When Enabled				
	0 to SERVOPACK capacity	10 W	0	Immediately				Set up

Be sure to set this parameter when installing an external regenerative resistor to the SERVOPACK. Set the regenerative resistor capacity within tolerance value.

The set value differs depending on the cooling method of external regenerative resistor:

- For natural convection cooling method: Set the value maximum 20 % of the actually installed regenerative resistor capacity (W).
- For forced convection cooling method: Set the value maximum 50 % of the actually installed regenerative resistor capacity (W).

Example: Set 20 W (100 W × 20 %) for the 100 W external regenerative resistor with natural convection cooling method:  
 Pn600 = 2 (units: 10 W)

- Note 1. When the set value is improper, alarm A.320 is detected.  
 2. When set to the factory setting of “0,” the SERVOPACK’s built-in regenerative resistor is used.

 <b>IMPORTANT</b>	<ol style="list-style-type: none"> <li>1. When the external regenerative resistors for power are used at the rated load ratio, the resistor temperature increases to between 200 °C and 300 °C. The resistors must be used at or below the rated values. Check with the manufacturer for the resistor’s load characteristics.</li> <li>2. For safety, use the external resistors with thermostiches.</li> </ol>
---	---

## 3.8 Noise Control and Measures for Harmonic Suppression

This section describes the wiring for noise control and the DC reactor for harmonic suppression.

### 3.8.1 Wiring for Noise Control



#### IMPORTANT

- Because the SERVOPACK is designed as an industrial device, it provides no mechanism to prevent noise interference.
- The SERVOPACK uses high-speed switching elements in the main circuit. It may receive switching noise from these high-speed switching elements if wiring or grounding around the SERVOPACK is not appropriate. Take measures against noise if the equipment is to be used near private houses or if there is concern about radio interference.
- Refer to *2.4 EMC Installation Conditions* in the  $\Sigma$ -V Series User's Manual Setup Linear Motor (SIEP S800000 44) if installation conditions of the EMC directive must be satisfied.

The SERVOPACK uses microprocessors and so it is susceptible to noise from peripheral devices. To prevent noise influence between the SERVOPACK and peripheral devices, take the following actions as required:

- Position the input reference device and noise filter as close to the SERVOPACK as possible.
- Always install a surge absorber in the relay, solenoid and electromagnetic contactor coils.
- The distance between a power line (linear servomotor main circuit cable) and a signal line must be at least 30 cm. Do not put the power and signal lines in the same duct or bundle them together.
- Do not share the power supply with an electric welder or electrical discharge machine. When the SERVOPACK is placed near a high-frequency generator, install a noise filter on the input side of the power supply line. As for the wiring of noise filter, refer to (1) *Noise Filter*.
- Take the grounding measures correctly. As for the grounding, refer to (2) *Correct Grounding*.

## (1) Noise Filter

The SERVOPACK has a built-in microprocessor (CPU), so protect it from external noise as much as possible by installing a noise filter in the appropriate place.

The following is an example of wiring for noise control.

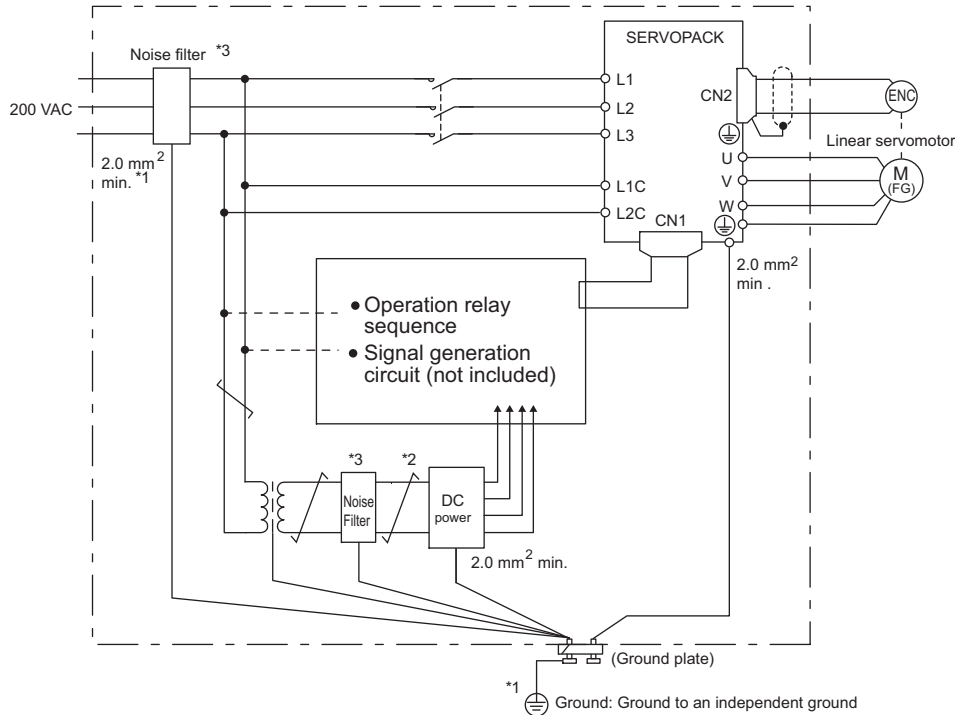

\*1. For ground wires connected to the ground plate, use a thick wire with a thickness of at least 2.0 mm<sup>2</sup> (preferably, plain stitch cooper wire).

\*2.  should be twisted-pair wires.

\*3. When using a noise filter, follow the precautions in 3.8.2 *Precautions on Connecting Noise Filter*.

## (2) Correct Grounding

Take the following grounding measures to prevent the malfunction due to noise.

### ■ Grounding the Motor Frame

Always connect linear servomotor frame terminal FG to the SERVOPACK ground terminal (⊕). Also be sure to ground the ground terminal (⊕).

If the linear servomotor is grounded via the machine, a switching noise current will flow from the SERVOPACK main circuit through linear servomotor stray capacitance. The above grounding is required to prevent the adverse effects of switching noise.

### ■ Noise on the I/O Signal Line

If the I/O signal lines are affected by noise, ground the 0 V (SG) terminal of I/O signal. If the main circuit wiring for the motor is in a metal conduit, ground the conduit and its junction box. For all grounding, ground at one point only.

### 3.8.2 Precautions on Connecting Noise Filter

This section describes the precautions on installing a noise filter.

#### (1) Precautions on Using Noise Filters

Always observe the following installation and wiring instructions.

Do not put the input and output lines in the same duct or bundle them together.

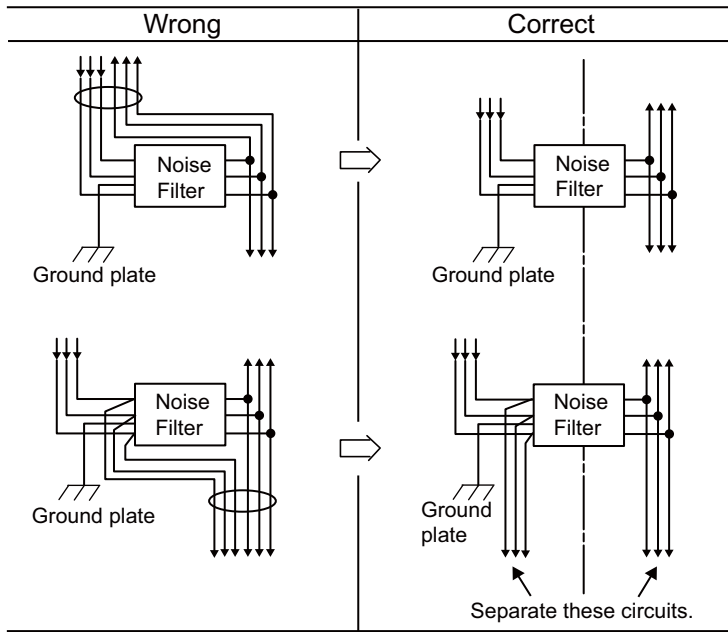

Separate the noise filter ground wire from the output lines.

Do not put the noise filter ground wire, output lines and other signal lines, in the same duct or bundle them together.

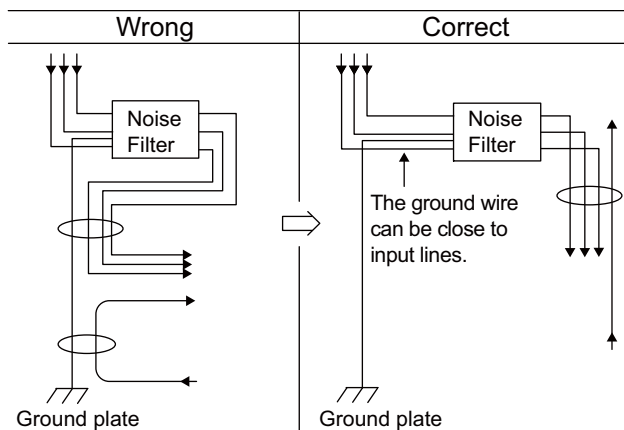

Connect the noise filter ground wire directly to the ground plate.  
Do not connect the noise filter ground wire to other ground wires.

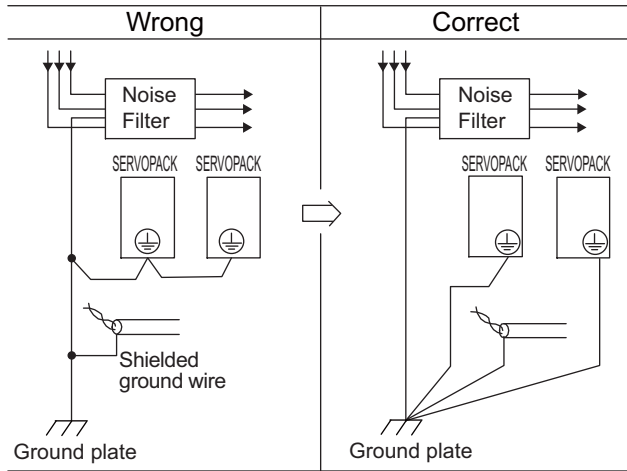

If a noise filter is located inside a control panel, connect the noise filter ground wire and the ground wires from other devices inside the control panel to the ground plate for the control panel first, then ground these wires.

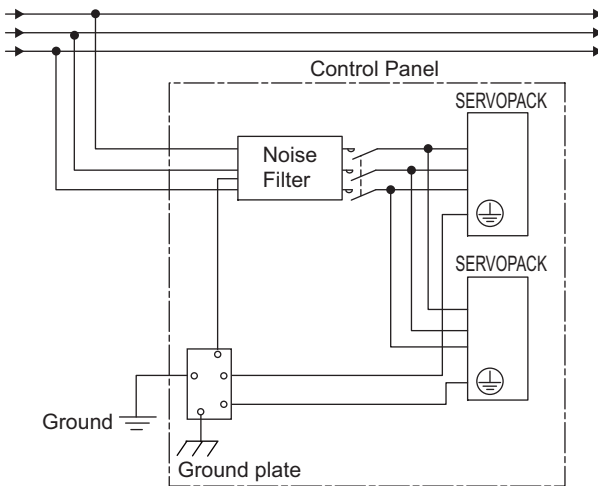

### 3.8.3 Connecting AC/DC Reactor for Harmonic Suppression

The SERVOPACK has reactor connection terminals for power supply harmonic suppression.

As for the precautions on selecting an AC or DC reactor and its specifications, refer to *ΣV series Product Catalog* (KAEP S800000 42).

Connect a reactor as shown in the following diagram.

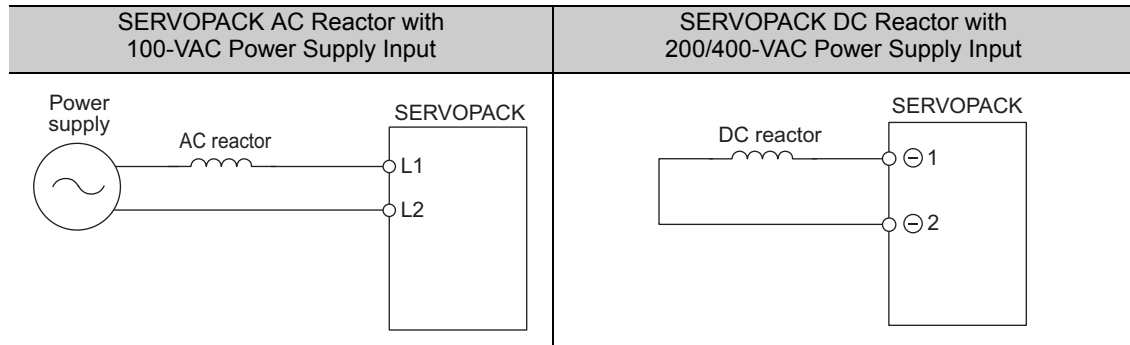

- Note 1. Connection terminals for DC reactor ⊖1 and ⊖2 are short-circuited at shipment. Remove the lead wire for short-circuit, and connect a DC reactor.
2. AC and DC reactors are not provided. (option)
3. A SERVOPACK with a single-phase, 100-V power supply input cannot be connected to a DC reactor.

4.1	Option Module Function Settings	4-3
4.1.1	Setting Switches S1 and S2 for Option Module Functions	4-3
4.2	Settings for Common Basic Functions	4-4
4.2.1	Inspection and Checking before Operation	4-4
4.2.2	Linear Servomotor Movement Direction	4-5
4.2.3	Overtravel	4-6
4.2.4	Electronic Gear	4-9
4.2.5	Encoder Output Pulse	4-12
4.2.6	Encoder Output Pulse Setting	4-14
4.2.7	Holding Brakes	4-15
4.2.8	Stopping Linear Servomotor after Receiving Servo OFF Command or Alarm Occurrence	4-19
4.2.9	Instantaneous Power Interruption Settings	4-21
4.2.10	Motor Maximum Speed	4-21
4.2.11	SEMI-F47 Function (Force Limit Function for Low Power Supply Voltage for Main Circuit)	4-22
4.2.12	Setting Motor Overload Detection Level	4-25
4.3	Test Without Motor Function	4-27
4.3.1	Related Parameters	4-27
4.3.2	Limitations	4-28
4.3.3	Digital Operator Display during Testing without Motor	4-29
4.4	Limiting Force	4-30
4.4.1	Internal Force Limit	4-30
4.4.2	External Force Limit	4-31
4.4.3	Checking Output Force Limiting during Operation	4-32
4.5	Setting Absolute Linear Scale	4-33
4.5.1	Setup Procedure	4-33
4.5.2	Origin Setting (Fn020)	4-34
4.5.3	Polarity Detection (Fn080)	4-35
4.5.4	Absolute Linear Scale Reception Sequence	4-36
4.6	Other Output Signals	4-39
4.6.1	Servo Alarm Output Signal (ALM)	4-39
4.6.2	Warning Output Signal (/WARN)	4-39
4.6.3	Movement Detection Output Signal (/TGON)	4-40
4.6.4	Servo Ready Output Signal (/S-RDY)	4-40



4.7 Safety Function .....	4-41
4.7.1 Hard Wire Base Block (HWBB) Function .....	4-41
4.7.2 External Device Monitor (EDM1) .....	4-46
4.7.3 Application Example of Safety Functions .....	4-48
4.7.4 Confirming Safety Functions .....	4-49
4.7.5 Connecting a Safety Device .....	4-50
4.7.6 Precautions for Safety Functions .....	4-51

## 4.1 Option Module Function Settings

This section describes how to set the option module functions.

### 4.1.1 Setting Switches S1 and S2 for Option Module Functions

The S1 and S2 Switches are used to make the settings for the Option Module Functions.

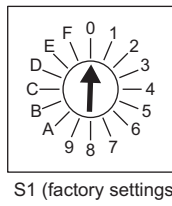

For details on S1 and S2 switches, refer to the manual of the connected Command Option Module.

## 4.2 Settings for Common Basic Functions

This section explains the settings for the common basic functions.

### 4.2.1 Inspection and Checking before Operation

To ensure safe and correct operation, inspect and check the following items before starting operation.

#### (1) Linear Servomotors

Inspect and check the following items and take appropriate measures before performing operation if any problem exists.

- Are all wiring and connections correct?
- Are all nuts and bolts securely tightened?

Note: When performing operation on a linear servomotor that has been stored for a long period of time, perform the maintenance and inspection according to the procedures described in *1.7 Inspection and Maintenance*.

#### (2) SERVOPACKs

Inspect and check the following items and take appropriate measures before performing operation if any problem exists.

- Are all wiring and connections correct?
- Is the correct power supply voltage being supplied to the SERVOPACK?

#### (3) Operating the Linear Servomotor Alone

JOG operation of the SERVOPACK enables checking linear servomotor operation using speed control without connection to the host controller.

For details, refer to the *Σ-V Series Users Manual Setup Linear Motor* (SIEP S800000 44).

For details on how to perform operation using the Command Option Module functions, refer to the manual of the connected Command Option Module.

### 4.2.2 Linear Servomotor Movement Direction

The linear servomotor movement direction can be reversed with parameter Pn000.0. This causes the travel direction (+, -) of the shaft to reverse, but the encoder output pulse and analog monitor signal polarity do not change. (Refer to 5.1.3 *Monitoring Analog Signals*.)

Before performing this operation, Motor Phase (Pn080.1) must be set correctly. For the setting method, refer to *Σ-V series User's Manual, Setup, Linear Motor* (SIEP S800000 44).

Parameter	Forward/Reverse Reference	Linear Servomotor Movement Direction and Encoder Output Pulses	Enabled Overtravel (OT)
<b>Pn000</b>	n.□□□0 Standard setting (Forward movement is the linear scale counting up direction.) [Factory setting]		P-OT
	Reverse reference		N-OT
	n.□□□1 Reverse movement Mode (Forward movement is the linear scale counting down direction.)		P-OT
	Reverse reference		N-OT

- Note 1. The figures in the table above show the trace waveforms for the SigmaWin+.  
 2. Use the Feedback Pulse Counter (Un00D) to check the linear scale count.

### 4.2.3 Overtravel

The overtravel limit function forces the linear servomotor to stop when movable machine parts exceed the allowable range of motion by turning ON a limit switch.

CAUTION

- **Installing Limit Switches**  
 Connect limit switches as shown below to prevent damage to the devices during linear motion. It is recommended using normally closed contacts for the limit switches to ensure safe operation in the event of a faulty contact or a disconnection in the contact.

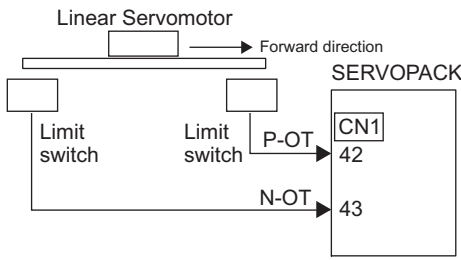

- **When using the linear servomotor on a vertical axis**  
 The workpiece may fall in the overtravel condition because the /BK signal is ON to release the brake. To prevent this, always set the zero clamp after stopping the linear servomotor with Pn001 = n.□□1□. Refer to (4) *Motor Stopping Method When Overtravel is Used* in this section.

#### (1) Signal Setting

Type	Name	Connector Pin Number	Input Status	Meaning
Input	P-OT	CN1-7	ON	Forward run allowed. Normal operation status.
			OFF	Forward run prohibited. Forward overtravel.
	N-OT	CN1-8	ON	Reverse run allowed. Normal operation status.
			OFF	Reverse run prohibited. Reverse overtravel.

Movement in the opposite direction is possible during overtravel by inputting the reference.

#### (2) Overtravel Displays

The following will be displayed on the panel display on the front of the SERVOPACK if overtravel occurs.

① Forward Overtravel (P-OT)



③ Forward and Reverse Overtravel

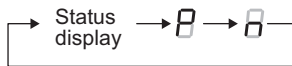

② Reverse Overtravel (N-OT)



### (3) Overtravel Function Setting

Parameters Pn50A and Pn50B can be set to enable or disable the overtravel function.

If the overtravel function is not used, no wiring for overtravel input signals will be required.

Parameter		Meaning	When Enabled	Classification
<b>Pn50A</b>	n.1□□□	Inputs the Forward Run Prohibited (P-OT) signal from CN1-7. [Factory setting]	After restart	Setup
	n.8□□□	Disables the Forward Run Prohibited (P-OT) signal. Allows constant forward movement.		
<b>Pn50B</b>	n.□□□2	Inputs the Reverse Run Prohibited (N-OT) signal from CN1-8. [Factory setting]		
	n.□□□8	Disables the Reverse Run Prohibited (N-OT) signal. Allows constant reverse movement.		

- A parameter can be used to re-allocate input connector number for the P-OT and N-OT signals. Refer to 3.3.1 *Input Signal Allocations*.

### (4) Motor Stopping Method When Overtravel is Used

There are three linear servomotor stopping methods when an overtravel is used.

- Stop by dynamic brake  
By short-circuiting the electric circuits, the linear servomotor comes to a quick stop.
- Decelerate to stop  
Stops by using deceleration (braking) force.
- Coast to a stop  
Stops naturally, with no control, by using the friction resistance of the linear servomotor in operation.

After stopping, there are two modes.

- Coast mode  
Stopped naturally, with no control, by using the friction resistance of the linear servomotor in operation.
- Zero clamp mode  
A mode forms a position loop by using the position reference zero.

The stopping method when an overtravel (P-OT, N-OT) signal is input while the linear servomotor is operating can be set with parameter Pn001.

Parameter		Stop Mode	Mode After Stopping	Meaning	When Enabled	Classification
<b>Pn001</b>	n.□□00	Stop by dynamic brake	Coast	Immediately stops the linear servomotor by dynamic braking (DB), then places it into Coast Mode.	After restart	Setup
	n.□□01			Stops the linear servomotor by coast stop, then places it into Coast Mode.		
	n.□□02	Coast to a stop				
	n.□□1□	Decelerate to stop	Zero Clamp	Decelerates the linear servomotor with emergency stop force (Pn406), then places it into Zero Clamp (Servolock) Mode.		
	n.□□2□		Coast	Decelerates the linear servomotor with emergency stop force (Pn406), then places it into Coast Mode.		

- A linear servomotor under force control cannot be decelerated to stop. The linear servomotor is stopped with the dynamic braking (DB) or coasts to a stop according to the setting of Pn001.0. After the linear servomotor stops, the servomotor will enter a coast state.
- For details on stopping methods after the servo OFF command is received or an alarm occurs, refer to 4.2.8 *Stopping Linear Servomotor after Receiving Servo OFF Command or Alarm Occurrence*.

#### ■ When Motor Stopping Method is Set to Decelerate to Stop

Emergency stop force can be set with Pn406.

Pn406	Emergency Stop Force				Classification
	Setting Range	Setting Unit	Speed	Position	
			Factory Setting	When Enabled	
	0 to 800	1%	800	Immediately	Setup

- The setting unit is a percentage of the rated force.
- The factory setting is 800% so that the setting is large enough a value to operate the linear servomotor at maximum force. The maximum value of emergency stop force that is actually available, however, is limited to the maximum force of the linear servomotor.

## 4.2.4 Electronic Gear

### (1) Linear Scale Feedback Resolution

The following table shows the pitch (Pn282) and the number of divisions for a linear scale.

Linear Scale Type	Manufacturer	Linear Scale Model	Linear Scale Pitch [ $\mu\text{m}$ ]	Serial Converter Unit Model	No. of Divisions	Resolution [ $\mu\text{m}$ ]
Incremental	Heidenhain Corporation	LIDA48□	20	JZDP-D003-□□□-E	256	0.078
				JZDP-G003-□□□-E	4096	0.0049
		LIDA18□	40	JZDP-D003-□□□-E	256	0.156
				JZDP-G003-□□□-E	4096	0.0098
		LIF48□	4	JZDP-D003-□□□-E	256	0.016
				JZDP-G003-□□□-E	4096	0.00098
Renishaw plc	RGH22B	20	JZDP-D005-□□□-E	256	0.078	
			JZDP-G005-□□□-E	4096	0.0049	
Absolute	Magnescale Co., Ltd.	SR77-□□□□□LF	80	—	8192	0.0098
		SR77-□□□□□MF	80	—	1024	0.078
	Mitutoyo Corporation	ST781A	256*	—	512*	0.5
		ST782A	256*	—	512*	0.5
		ST783	51.2*	—	512*	0.1
		ST784	51.2*	—	512*	0.1

\* These values are set to facilitate the internal processing of the SERVOPACK.

For details on the pitch (Pn282) and the number of divisions for a linear scale, refer to the manuals of the linear scale and serial converter unit to be used.

### (2) Electronic Gear

The electronic gear enables the workpiece travel distance per input reference pulse from the host controller to be set to any value. One reference pulse from the host controller, i.e., the minimum position data unit, is called a reference unit.

<Example> When the number of divisions of serial converter unit is 256:

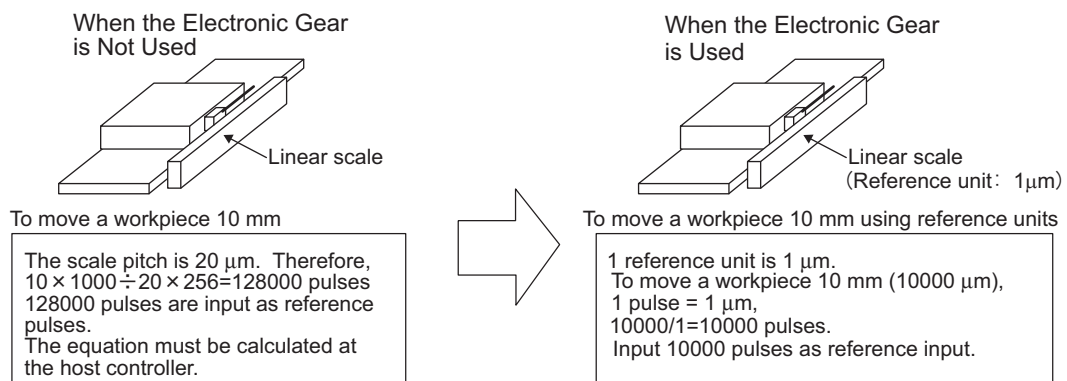



### (3) Electronic Gear Ratio

Set the electric gear ratio using Pn20E and Pn210.

<b>Pn20E</b>	Electronic Gear Ratio (Numerator) <span style="float: right;">Position</span>				Classification
	Setting Range	Setting Unit	Factory Setting	When Enabled	
	1 to 1073741824 ( $2^{30}$ )	–	4	After restart	Setup
<b>Pn210</b>	Electronic Gear Ratio (Denominator) <span style="float: right;">Position</span>				Classification
	Setting Range	Setting Unit	Factory Setting	When Enabled	
	1 to 1073741824 ( $2^{30}$ )	–	1	After restart	Setup

Use the following equation to calculate the electronic gear ratio.

$$\text{Electronic gear ratio} = \frac{B}{A} = \frac{\text{Pn20E}}{\text{Pn210}} = \frac{\text{Travel distance per position reference pulse (reference unit)} \times \text{Number of divisions}}{\text{Linear scale pitch}}$$

Pn20E (Numerator B) and Pn210 (Denominator A) must be integers.

The set value must be within the range  $0.001 \leq \frac{B}{A} \leq 4000$ .

 <b>IMPORTANT</b>	<p>Electronic gear ratio setting range:  <math>0.001 \leq \text{Electronic gear ratio (B/A)} \leq 4000</math>            If the electronic gear ratio is outside this range, a parameter setting error (A.040) will be output.</p>
---	--

### (4) Procedure for Setting the Electronic Gear Ratio

Electronic gear ratio set value differs depending on the machine specifications. Use the following procedure to set the electronic gear ratio.

Step	Operation
1	Check the scale pitch. Check the scale pitch of linear scale used.
2	Determine the reference unit used. Determine the reference unit from the host controller, considering the machine specifications and positioning accuracy.
3	Calculate the electronic gear ratio. Use the electronic gear ratio equation to calculate the ratio.
4	Set parameters. Set parameters Pn20E and Pn210 using the calculated values.
5	Turn OFF the power supply and then ON again to validate the setting.

## (5) Electronic Gear Ratio Equation

Refer to the following equation to determine the electronic gear ratio.

<Example>

When the number of divisions in the serial converter unit is 256:

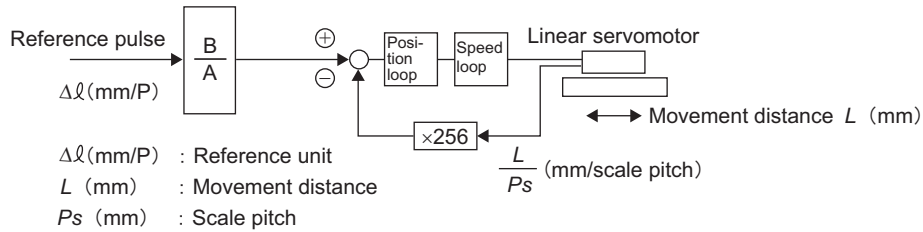

$$\frac{L}{\Delta l} \times \left( \frac{B}{A} \right) = 256 \times \frac{L}{P_s}$$

$$\left( \frac{B}{A} \right) = \frac{256 \times L \times \Delta l}{P_s \times L} = \frac{256 \times \Delta l}{P_s}$$

Set A and B with the following parameters.

$\boxed{A}$  : Pn210     $\boxed{B}$  : Pn20E

## (6) Electronic Gear Ratio Setting Example

An example of electronic gear ratio setting is given below.

<Example>

When the number of divisions in the serial converter unit is 256:

Step	Operation	Load Configuration
1	Check the scale pitch.	0.02 mm (20 $\mu$ m)
2	Determine the reference unit.	1 reference unit: 0.001 mm (1 $\mu$ m)
3	Calculate the electronic gear ratio.	$\frac{B}{A} = \frac{1 (\mu\text{m})}{20 (\mu\text{m})} \times 256$
4	Set parameters.	Pn20E      256
		Pn210      20

## 4.2.5 Encoder Output Pulse

The encoder output pulse is the signal processed by the SERVOPACK after being received from the encoder and is then output in the form of 2-phase pulses (phase A and B) with 90° phase differential to an external device. It is used as positioning feedback for the host controller.

Signals and output phase form are as shown below.

### (1) Signals

Type	Signal Name	Connector Pin Number	Name
Output	PAO	CN1-17	Encoder output pulse: phase A
	/PAO	CN1-18	Encoder output pulse: phase /A
	PBO	CN1-19	Encoder output pulse: phase B
	/PBO	CN1-20	Encoder output pulse: phase /B
	PCO	CN1-21	Encoder output pulse: phase C*
	/PCO	CN1-22	Encoder output pulse: phase /C*

\* For details on phase C (origin pulse), refer to (3) *Encoder Output Signals from SERVOPACK with a Linear Scale by Renishaw*.

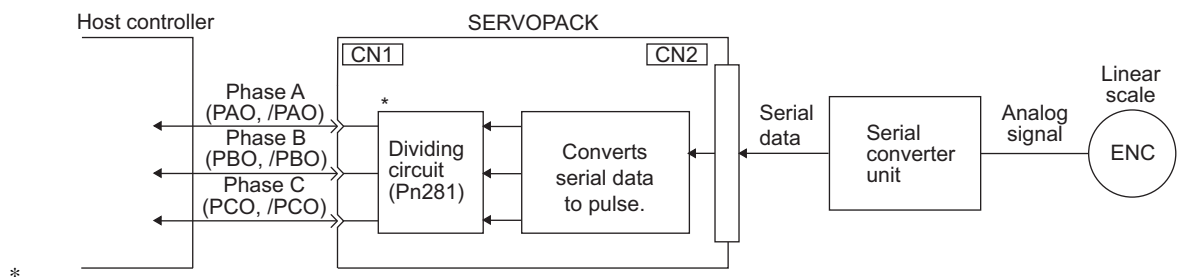

### (2) Output Phase Form

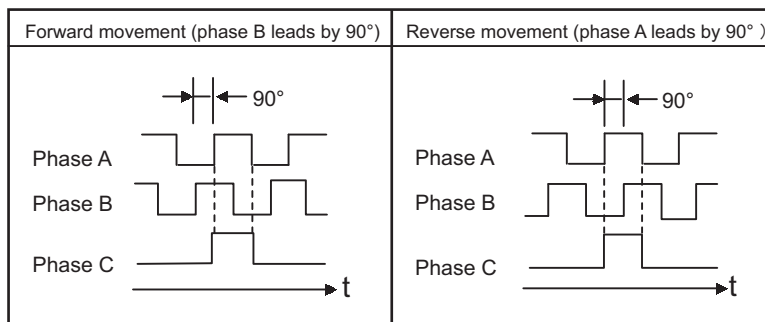

Note: The pulse width of the phase C (origin pulse) changes according to the setting of the Pn281 and becomes the same as that for phase A.

Even in reverse movement mode (Pn000.0 = 1), the output phase form is the same as that for the standard setting (Pn000.0 = 0).

### (3) Encoder Output Signals from SERVOPACK with a Linear Scale by Renishaw

The output position of the zero point signal (Ref) may vary in some models of the linear scale made by Renishaw.

If using a Renishaw model, the phase-C pulses of the SERVOPACK are output at two positions.

For details on the specifications of the zero-point signals for a linear scale, refer to the manual for the Renishaw linear scale.

- Forward/Reverse Pass over 1st Zero Point Signal (Ref) after Turning Power ON

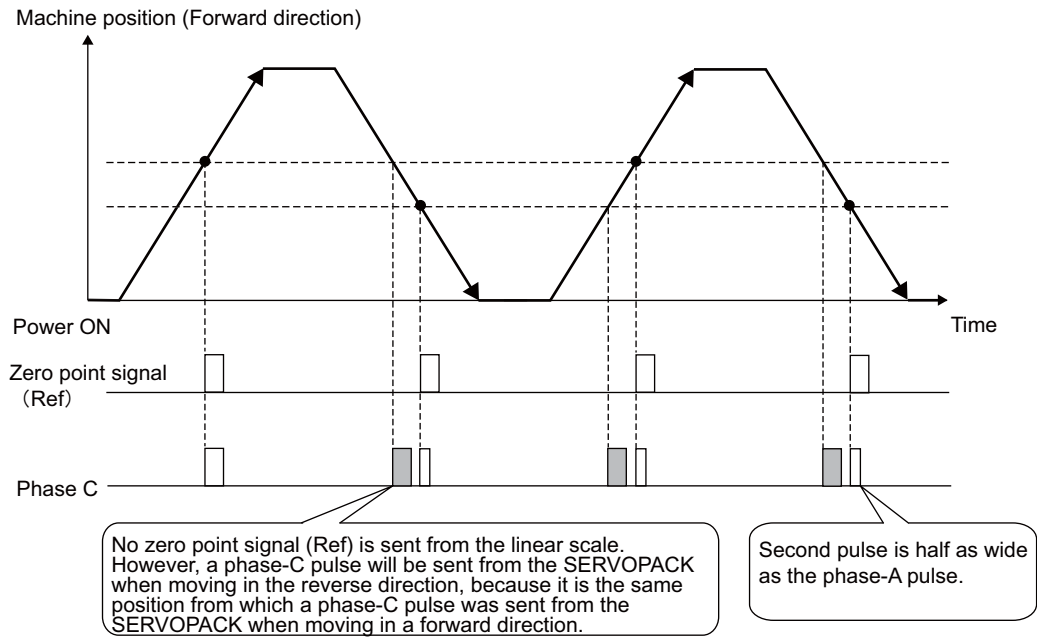

- Reverse/Forward Pass over 1st Zero Point Signal (Ref) after Turning Power ON

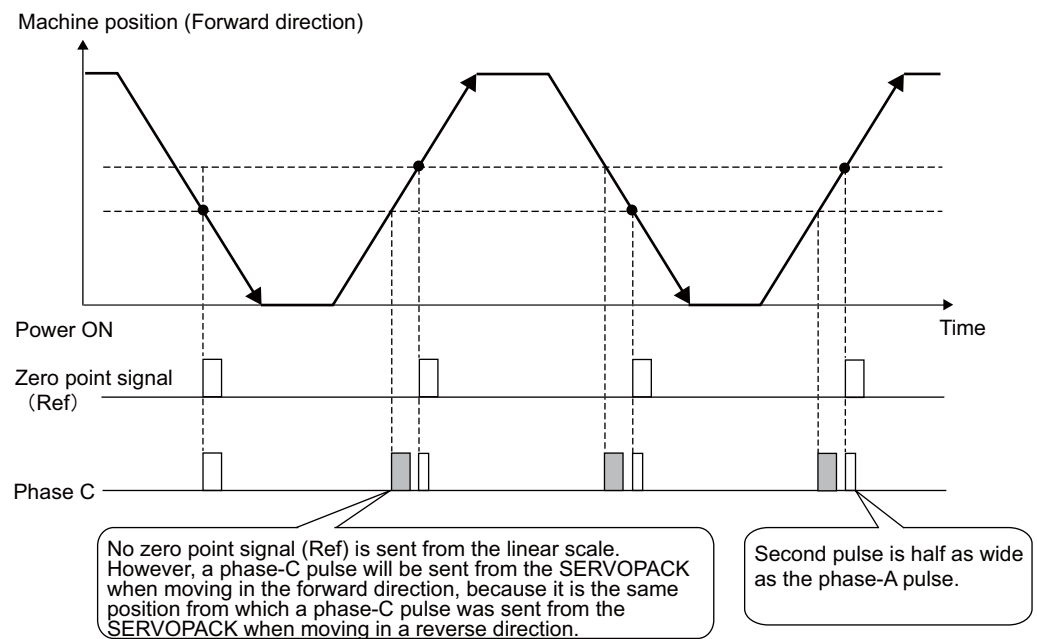

## 4.2.6 Encoder Output Pulse Setting

Set the encoder output pulse using the following parameter.

Pn281	Encoder Output Resolution				Classification	
			Speed	Position		Force
	Setting Range	Setting Unit	Factory Setting	When Enabled		
	1 to 4096	1 edge/pitch	20	After restart		
					Setup	

Set the encoder output pulse for encoder output pulse signals (PAO, /PAO, PBO, /PBO) externally from the SERVOPACK.

Feedback pulses per linear scale pitch (Pn282) are divided inside the SERVOPACK by the value set in Pn281 before being output. Set according to the system specifications of the machine or host controller.

The setting range varies with the linear servomotor maximum speed (Pn385) and linear scale pitch (Pn282). The upper limit value for Pn281 can be obtained by the following equation.

$$\text{Upper limit value for Pn281} = \frac{\text{Pn282}}{\text{Pn385}} \times 72$$

- Note 1. When the scale pitch is 4 μm, the motor maximum speed is limited to 1 m/s because of the maximum response frequency of serial converter unit.
2. If the set value is out of the setting range or does not satisfy the setting conditions, the alarm "Encoder Output Pulse Setting Error" (A.041) is output.  
If the motor speed exceeds the upper limit value according to the set encoder output resolution, the alarm "Over-speed of Encoder Output Pulse Rate" (A.511) is output.
3. The upper limit of encoder output resolution is limited by the frequency dividing specification of serial converter unit.
4. When an absolute linear scale made by Mitutoyo Corporation is used, the linear scale pitch becomes the value which is obtained by "resolution (μm/pulse)×512." (The set value in Pn282 becomes invalid.)

### ■ Setting Example

When the linear scale pitch = 20 μm (Pn282 = 20.00) and the motor maximum speed = 5 m/s (Pn385 = 50), Pn281 = 28 is accepted, but Pn281 = 29 is not accepted and A.041 is output.

### ■ Output Example

When Pn281 = 20 (20-edge output (5-pulse output) per linear scale pitch),

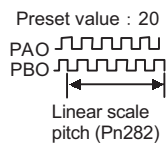

## 4.2.7 Holding Brakes

A holding brake is a brake used to hold the position of movable parts when the SERVOPACK is turned OFF so that movable parts do not move due to their own weight or external forces. Separately provide a brake on the machine side.



Do not keep the servo ON state with the brake applied.

IMPORTANT

There is a delay in the braking operation. Set the following ON/OFF timing.

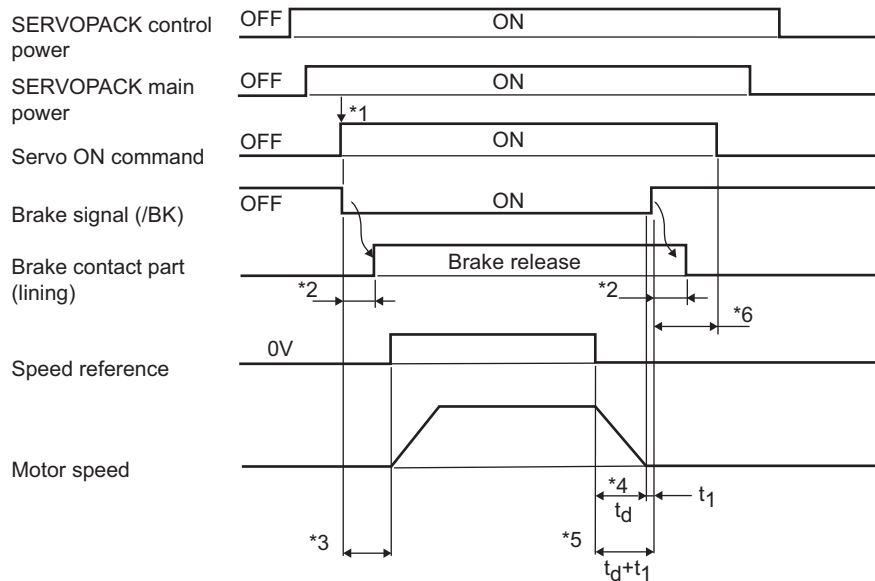

- \*1. The brake signal (/BK) turns ON at the timing the servo ON command is input.
- \*2. The operation delay time of the brake depends on the model. Set the ON/OFF timing according to the specifications of the brake used.
- \*3. Allow a period of time required for the brake to be fully released before the speed reference is input after the brake power supply is turned ON.
- \*4. The linear servomotor stop time is shown by  $t_d$ . Use the following formula for the calculation of  $t_d$ .

$$t_d = \frac{(M_M + M_L) \times V_M}{(F_D + F_L)}$$

$M_M$ : Moving coil mass (kg)       $M_L$ : Load mass (kg)

$V_M$ : Motor speed ( $\text{min}^{-1}$ )       $F_D$ : Motor deceleration force (N)

$F_L$ : Load force (Force from load side) (N)

- \*5. Make the settings so that the brake is applied after the linear servomotor comes to a stop. Usually, set  $t_d + t_1$  to 1 or 2 seconds.
- \*6. Use Pn506, Pn508, and Pn583 to set the timing of when the brake will be activated and when the linear servomotor power will be turned OFF.

### (1) Wiring Example

Use the SERVOPACK contact output signal /BK and the brake power supply to form a brake ON/OFF circuit. The following diagram shows a standard wiring example.

The timing can be easily set using the brake signal (/BK).

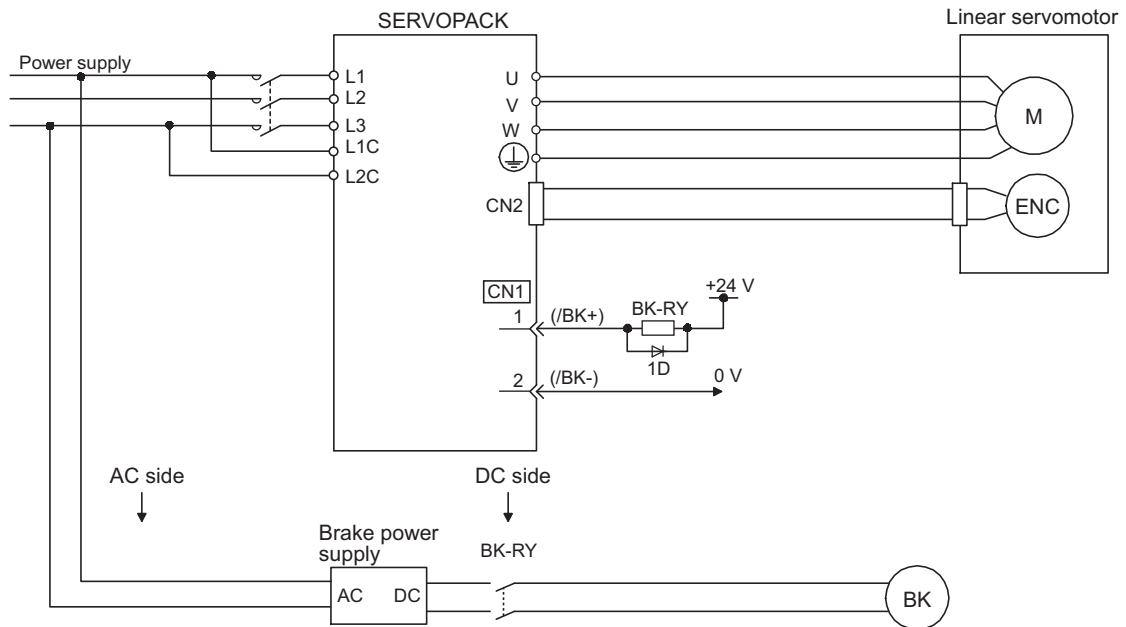

**IMPORTANT**

- Configure the relay circuit to apply the holding brake by the emergency stop.

**Relay Circuit Example**

### (2) Signal Setting

This output signal controls the brake.

The /BK signal turns OFF when an alarm is detected or the servomotor power is OFF. The brake OFF timing can be adjusted with Pn506.

The allocation of the /BK signal can be changed. Refer to (3) Brake Signals (/BK) Allocation for details.

Type	Name	Connector Pin Number	Setting	Meaning
Output	/BK	CN1-1, CN1-2	ON (close)	Releases the brake.
			OFF (open)	Applies the brake.

**IMPORTANT**

The /BK signal remains ON during overtravel. The brake is released.

### (3) Brake Signals (/BK) Allocation

Use the parameter Pn50F.2 to allocate the /BK signal.

Parameter	Connector Pin Number		Meaning	When Enabled	Classification	
	+ Terminal	- Terminal				
Pn50F	n.□0□□	–	–	The /BK signal is not used.	After restart	Setup
	n.□1□□	CN1-1	CN1-2	The /BK signal is output from output terminal CN1-1, 2. [Factory setting]		
	n.□2□□	CN1-23	CN1-24	The /BK signal is output from output terminal CN1-23, 24.		
	n.□3□□	CN1-25	CN1-26	The /BK signal is output from output terminal CN1-25, 26.		



**IMPORTANT** When multiple signals are allocated to the same output terminal, the signals are output with OR logic. For the /BK signal, do not use the output terminal that is already being used for another signal.

### (4) Brake ON Timing after the Linear Servomotor Stops

When the linear servomotor stops, the /BK signal turns OFF at the same time as the servo ON command is turned OFF. The Pn506 parameter can be used to change the timing at which the servo ON command turns OFF and power is not supplied to the linear servomotor.

Pn506	Brake Reference-Servo OFF Delay Time				Classification
	Setting Range	Setting Unit	Factory Setting	When Enabled	
	0 to 50	10 ms	0	Immediately	

- When using the linear servomotor to control a vertical axis, the machine movable part may shift slightly depending on the brake ON timing due to gravity or an external force. By using this parameter to turn the servo OFF after the brake is applied, the slight shift can be eliminated.
- This parameter changes the brake ON timing while the linear servomotor is stopped.

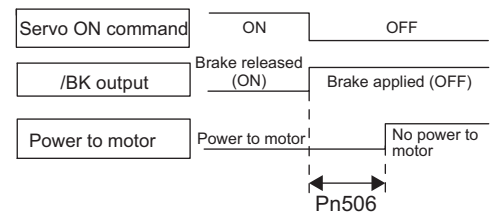



**IMPORTANT** The linear servomotor will turn OFF immediately when an alarm occurs, regardless of the setting of this parameter. The machine movable part may shift due to gravity or external force during the time until the brake operates.



### (5) Brake (/BK) Signal Output Timing during Linear Servomotor Operation

If an alarm occurs while the linear servomotor is running, the linear servomotor will come to a stop and the brake (/BK) signal will be turned OFF. The timing of brake signal (/BK) output can be adjusted by setting the brake reference output speed level (Pn583) and the waiting time for brake signal when motor running (Pn508).

Note: If the linear servomotor is set so that it comes to a zero-speed stop for an alarm, follow the information in (4) *Brake ON Timing after the Linear Servomotor Stops* after the motor comes to a stop for a zero position reference.

<b>Pn583</b>	Brake Reference Output Speed Level <span style="float:right">Speed Position Force</span>				Classification
	Setting Range	Setting Unit	Factory Setting	When Enabled	
	0 to 10000	1 mm/s	100	Immediately	Setup
<b>Pn508</b>	Waiting Time for Brake Signal When Motor Running <span style="float:right">Speed Position Force</span>				Classification
	Setting Range	Setting Unit	Factory Setting	When Enabled	
	10 to 100	10 ms	50	Immediately	Setup

#### /BK Signal Output Conditions When Linear Servomotor Running

The brake is applied when either of the following conditions is satisfied:

- When the motor speed falls below the level set in Pn583 after the power to the linear servomotor is turned OFF.
- When the time set in Pn508 is exceeded after the power to the linear servomotor is turned OFF.

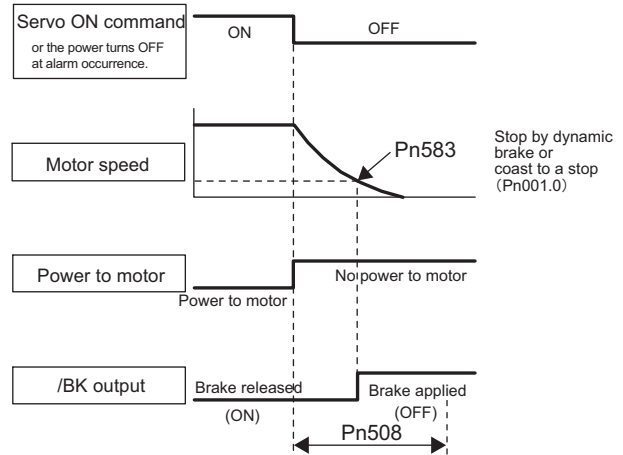



**IMPORTANT**

- The linear servomotor will be limited to its maximum speed even if the value set in Pn583 is higher than the maximum speed.
- Do not allocate the motor movement detection signal (/TGON) and the brake signal (/BK) to the same terminal, otherwise the /TGON signal will be turned ON by the falling speed on a vertical axis, and the brake may not be turned ON.

For the /BK signal, do not use the terminal that is already being used for another signal.

## 4.2.8 Stopping Linear Servomotor after Receiving Servo OFF Command or Alarm Occurrence

The stopping method can be selected after the servo OFF command is received or an alarm occurs.



**IMPORTANT**

- Dynamic braking (DB) is used for emergency stops. The DB circuit will operate frequently if the power is turned ON and OFF with a reference input applied, which may result in deterioration of the internal elements in the SERVOPACK. Use speed input references or position references to start and stop the linear servomotor.
- If the main circuit power supply (L1, L2, and L3) or the control power supply (L1C, L2C or 24V, 0V depending on the SERVOPACK model) is turned OFF before the servo OFF command is received, the stopping method for linear servomotor cannot be set by parameters.
  - If turning OFF the main circuit power supply before the servo OFF command is received, the linear servomotor will be stopped by dynamic braking.
  - If turning OFF the control power supply before the servo OFF command is received, the stopping method will vary with the SERVOPACK model. Two stopping methods are available.
    - Coasting  
Applicable models: SGD V-330A, 470A, 550A, 590A, 780A, 280D, 370D
    - Dynamic braking  
Applicable models: All SERVOPACKs other than those listed for coasting.
- If the linear servomotor must be stopped during operation by coasting rather than by dynamic braking when the main circuit power supply or the control power supply is OFF, arrange the sequence externally so the current will be cut off for wires U, V, and W.
- To minimize the coasting distance of the linear servomotor to come to a stop, the zero-speed stopping method is factory-set for alarms to which the zero-speed stop method is applicable. The DB stopping method may be more suitable than the zero-speed stopping method, however, depending on the application. Change the method to the DB stopping method as required by the application. For example, for multiple axes coupling operation (a twin-drive operation), machinery damage may result if a zero-speed stop alarm occurs for one of the coupled shafts and the other shaft stops by dynamic brake. In such cases, change the method to the DB stopping method.

### (1) Stopping Method for Linear Servomotor After Servo OFF Command is Received

Use Pn001.0 to select the stopping method for the linear servomotor after the servo OFF command is received.

Parameter	Stop Mode	Mode After Stopping	Meaning	When Enabled	Classification
Pn001	n.□□□0	Stop by dynamic brake	Dynamic Brake	After restart	Setup
	n.□□□1		Coast		
	n.□□□2	Coast to a stop	Coast		

Note: Similar to the Coast Mode, the n.□□□0 setting (which stops the linear servomotor by dynamic braking and then holds it in Dynamic Brake Mode) does not generate any braking force when the linear servomotor stops or when it moves at very low speed.

## (2) Stopping Method for Linear Servomotor When an Alarm Occurs

There are two type of alarms (Gr.1 and Gr.2), depending on the stopping method when an alarm occurs.

Select the stopping method for the linear servomotor when an alarm occurs using Pn001.0 and Pn00B.1.

The stopping method for the linear servomotor for a Gr.1 alarm is set to Pn001.0.

The stopping method for the linear servomotor for a Gr.2 alarm is set to Pn00B.1.

Refer to the information on alarm stopping methods in *8.1.1 List of Alarms*.

### ■ Stopping Method for Linear Servomotor for Gr.1 Alarms

The stopping method of the linear servomotor when a Gr.1 alarm occurs is the same as that for the linear servomotor after the servo OFF command is received.

Parameter		Stop Mode	Mode After Stopping	Meaning	When Enabled	Classification
Pn001	n.□□□0	Stop by dynamic brake	Dynamic Brake	Stops the linear servomotor by dynamic braking (DB), then holds it in Dynamic Brake Mode. [Factory setting]	After restart	Setup
	n.□□□1		Coast	Stops the linear servomotor by dynamic braking (DB), then places it into Coast Mode.		
	n.□□□2	Coast to a stop	Coast	Stops the linear servomotor by coasting, and continues in Coast Mode.		

### ■ Stopping Method for Linear Servomotor for Gr.2 Alarms

Parameter		Stop Mode	Mode After Stopping	Meaning	When Enabled	Classification
Pn00B	Pn001					
n.□□□□ [Factory setting]	n.□□□0 [Factory setting]	Zero-speed stopping	Dynamic Brake	Stops the linear servomotor by zero-speed stop, then holds it in Dynamic Brake Mode.	After restart	Setup
	n.□□□1		Coast	Stops the linear servomotor by zero-speed stop, then places it into Coast Mode.		
	n.□□□2			Stops the linear servomotor by zero-speed stop, then places it into Coast Mode.		
n.□□1□	n.□□□0 [Factory setting]	Stops by dynamic brake	Dynamic Brake	Stops the linear servomotor by dynamic braking (DB), then holds it in Dynamic Brake Mode.	After restart	Setup
	n.□□□1		Coast	Stops the linear servomotor by dynamic braking (DB), then places it into Coast Mode.		
	n.□□□2	Coast to stop	Stops the linear servomotor by coasting, and continues in Coast Mode.			

Note: The setting of Pn00B.1 is effective for position control and speed control. Pn00B.1 will be ignored for force control and only the setting of Pn001.0 will be valid.

### 4.2.9 Instantaneous Power Interruption Settings

Determines whether to continue operation or turn the linear servomotor's power OFF when the power supply voltage is interrupted.

<b>Pn509</b>	Instantaneous Power Cut Hold Time <span style="float:right">Speed   Position   Force</span>				Classification
	Setting Range	Setting Unit	Factory Setting	When Enabled	
	20 to 1000	1 ms	20	Immediately	Setup

An instantaneous power interruption will be detected when the main circuit power supply is turned OFF. If the time required to restore the main circuit power supply is less than the parameter set value, the servo will continue operating. If the restoration time is the equal to or greater than the set value, the linear servomotor's power is turned OFF.

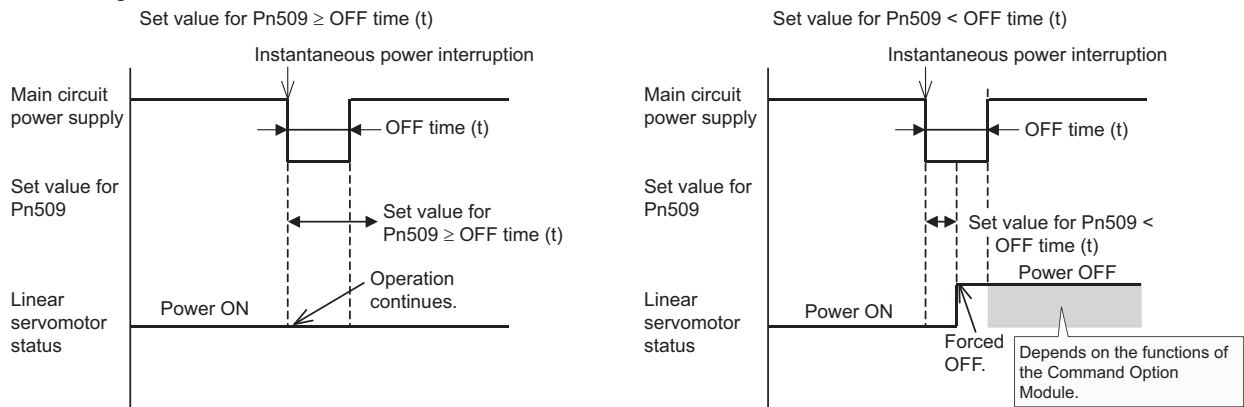



**IMPORTANT**

- The holding time of the control power supply for the 200 V SERVOPACK is approximately 100 ms, but the time of the control power supply for the 100 V SERVOPACKs is approximately 65 ms. If the control power supply makes control impossible during an instantaneous power interruption, the same operation will be performed as for normally turning OFF the power supply, and the setting of the parameter will be ignored.
- The holding time of the main circuit power supply varies with the output of the SERVOPACK. If the load on the linear servomotor is large and an undervoltage alarm (A.410) occurs, the parameter will be ignored.
- The holding time of the control power supply (24 VDC) for the 400 V SERVOPACKs depends on the capability of the power supply (not included). Check the power supply before using the application.

If the uninterruptible power supplies are used for the control power supply and main circuit power supply, the SERVOPACK can withstand an instantaneous power interruption period in excess of 1000 ms.

### 4.2.10 Motor Maximum Speed

By setting the linear servomotor maximum speed to a lower speed, the following effects can be obtained.

- More delicate speed control and more strict protection by generating the overspeed alarm (A.510)
- Allows the upper limit of Encoder Output Resolution (Pn281) to be set higher.

For details, refer to 4.2.5 Encoder Output Pulse.

<b>Pn385</b>	Motor Maximum Speed <span style="float:right">Speed   Position   Force</span>				Classification
	Setting Range	Setting Unit	Factory Setting	When Enabled	
	1 to 100	100 mm/s	50	After restart	Setup

### 4.2.11 SEMI-F47 Function (Force Limit Function for Low Power Supply Voltage for Main Circuit)

The force limit function detects a low voltage and limits the output current if the power supply voltage for the main circuit drops to a specified value or below.

This function complies with SEMI F47 standards for semiconductor production equipment.

Combining this function with the parameter for Instantaneous Power Cut Hold Time allows the linear servomotor to continue operating without stopping for an alarm or without recovery work even if the power supply voltage drops.



#### IMPORTANT

- The function is able to cope with instantaneous power interruptions in the voltage and time ranges stipulated in SEMI F47. An uninterruptible power supply (UPS) is required as a backup for instantaneous power interruptions that exceed these voltage and time ranges.
- The function is intended for voltage drops in the main circuit power supply. The following restrictions apply when it is used to provide an instantaneous power cut hold time in the control power supply. (There are no restrictions for the 200 V SERVOPACKs.)

#### <Control Power Supply Restrictions>

400 V SERVOPACKs: Provide the control power supply from a 24 VDC power supply that complies with SEMI F47 standards.

100 V SERVOPACKs: Provide the control power supply from an uninterruptible power supply (UPS).

- Set the host controller and SERVOPACK force limit so that a force reference that exceeds the specified acceleration will not be output when the power supply for the main circuit is restored.
- Do not limit the force to values lower than the holding force for the vertical axis.
- This function controls force within the range of the SERVOPACK's capability when the power is cut. It is not intended for use under all load and operating conditions. Use the actual device to set parameters while confirming correct operation.
- Setting the Instantaneous Power Cut Hold Time (P.509) lengthens the amount of time from when the power supply is turned OFF until the power actually stops flowing to the linear servomotor. Send the servo OFF command to stop flowing the power to the linear servomotor.

### (1) Execution Method

This function can be executed either with the host controller or independently with the SERVOPACK.

Use Pn008.1 to select whether or not the force limit function is executed with the host controller or independently with the SERVOPACK.

#### ■ Execution with Host Controller (Pn008 = n.□□1□)

The host controller limits the force in response to a low-voltage warning.  
The force is no longer limited when the low-voltage warning is cleared.

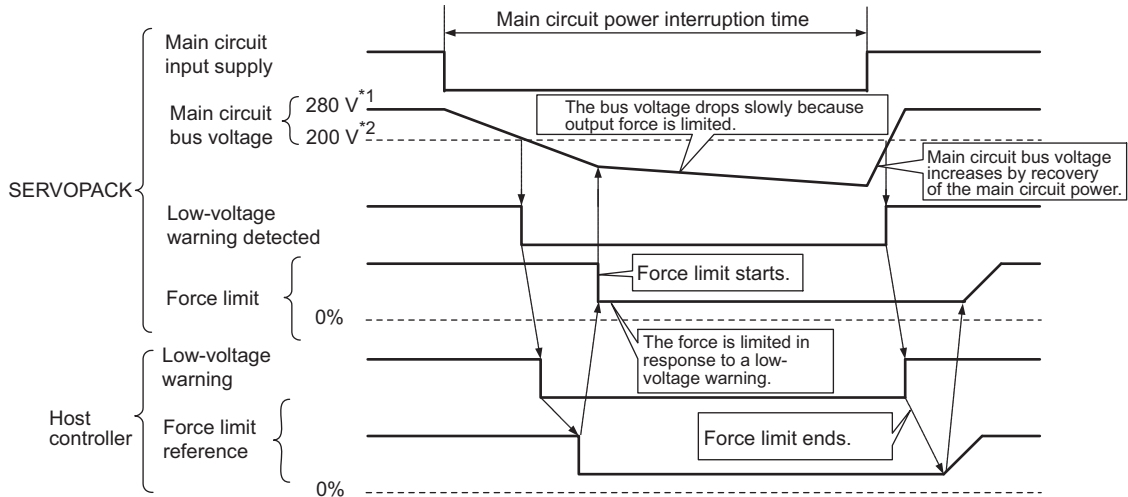

\*1: 560 V for 400 V power supply.  
\*2: 400 V for 400 V power supply.

#### ■ Execution Independently with SERVOPACK (Pn008 = n.□□2□)

The force is limited in the SERVOPACK in response to a low-voltage warning.  
The SERVOPACK stops limiting the force in the set time (Pn425) when the low-voltage warning is cleared.

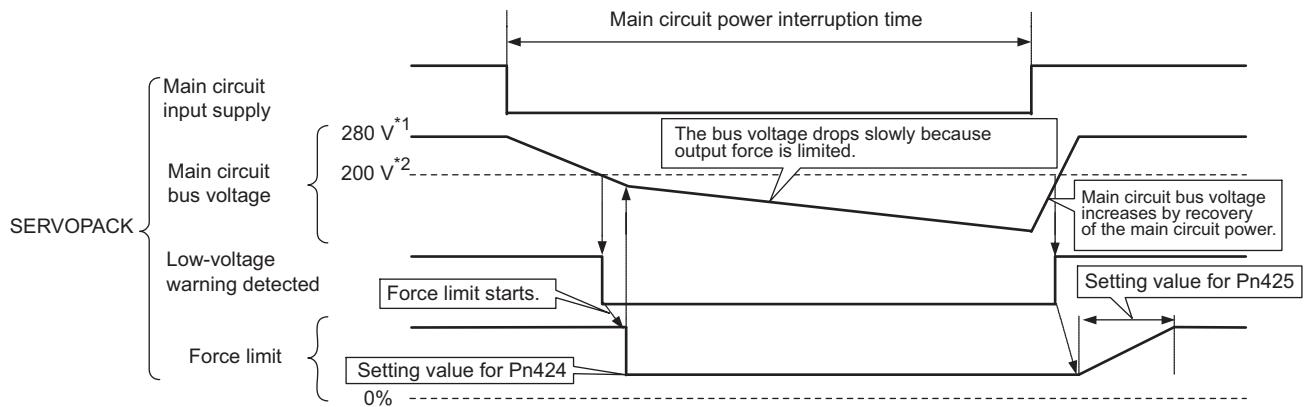

\*1: 560 V for 400 V power supply.  
\*2: 400 V for 400 V power supply.

## (2) Related Parameters

Parameter	Meaning	When Enabled	Classification
Pn008	n.□□0□	A main circuit low voltage is not detected. [Factory setting]	After restart Setup
	n.□□1□	A main circuit low voltage is detected, and the host controller limits the force.	
	n.□□2□	A main circuit low voltage is detected, and the SERVOPACK independently limits the force using Pn424 and Pn425.	

Pn424	Force Limit at Main Circuit Voltage Drop <input type="checkbox"/> Speed <input type="checkbox"/> Position <input type="checkbox"/> Force				Classification
	Setting Range	Setting Unit	Factory Setting	When Enabled	
	0 to 100	1% *	50	Immediately	Setup
Pn425	Release Time for Force Limit at Main Circuit Voltage Drop <input type="checkbox"/> Speed <input type="checkbox"/> Position <input type="checkbox"/> Force				Classification
	Setting Range	Setting Unit	Factory Setting	When Enabled	
	0 to 1000	1 ms	100	Immediately	Setup

\* The setting unit is a percentage of the motor rated force.

Pn509	Instantaneous Power Cut Hold Time <input type="checkbox"/> Speed <input type="checkbox"/> Position <input type="checkbox"/> Force				Classification
	Setting Range	Setting Unit	Factory Setting	When Enabled	
	20 to 1000	1 ms	20	Immediately	Setup

Note: When using SEMI F47 function, set 1000 ms.

### 4.2.12 Setting Motor Overload Detection Level

In this SERVOPACK, the detection timing of the overload warning (A.910) and overload (continuous overload) alarm (A.720) can be changed.

The overload characteristics and the detection level of the overload (instantaneous overload) alarm (A.710) cannot be changed.

#### (1) Changing Detection Timing of Overload Warning (A.910)

The overload warning level is set by default to 20% so that an overload warning is detected in 20% of the time required to detect an overload alarm. The time required to detect an overload warning can be changed by changing the setting of the overload warning level parameter (Pn52B). This protective function enables the overload warning output signal (/WARN) serve as a protective function and to be output at the best timing for your system.

The following graph shows an example of the detection of an overload warning when the overload warning level (Pn52B) is changed from 20% to 50%. An overload warning is detected in half of the time required to detect an overload alarm.

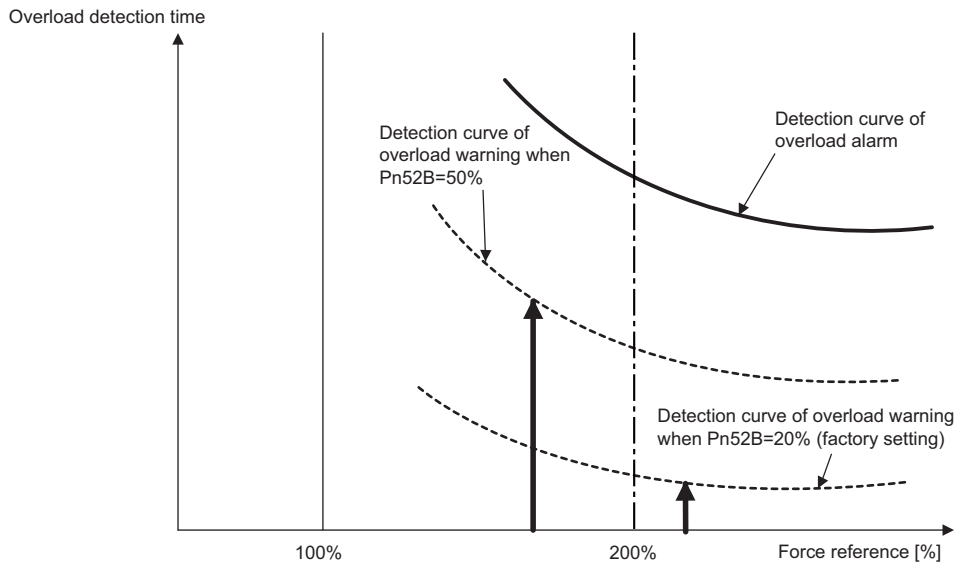

<b>Pn52B</b>	Overload Warning Level <span style="float: right;"><input type="checkbox"/> Speed <input type="checkbox"/> Position <input type="checkbox"/> Force</span>				Classification
	Setting Range	Setting Unit	Factory Setting	When Enabled	
	1 to 100	1%	20	Immediately	Setup



## (2) Changing Detection Timing of Overload Alarm (A.720)

An overload alarm (continuous overload) can be detected earlier to protect the motor from overloading. The time required to detect an overload alarm can be shortened by using the derated motor base current obtained with the following equation. The detection level of the overload (instantaneous overload) alarm (A.710) cannot be changed.

$$\text{Motor base current} \times \text{Derating of base current at detecting overload of motor (Pn52C)} = \text{Derated motor base current}$$

Motor base current: Threshold value of linear servomotor current to start calculation for overload alarm  
 Derating of base current at detecting overload of motor (Pn52C): Derating of motor base current

The following graph shows an example of the detection of an overload alarm when Pn52C is set to 50%. The calculation for the overload alarm of motors starts at 50% of the motor base current and then an overload alarm will be detected earlier.

Changing the setting of Pn52C will change the detection timing of the overload alarm, so the time required to detect the overload warning will also be changed.

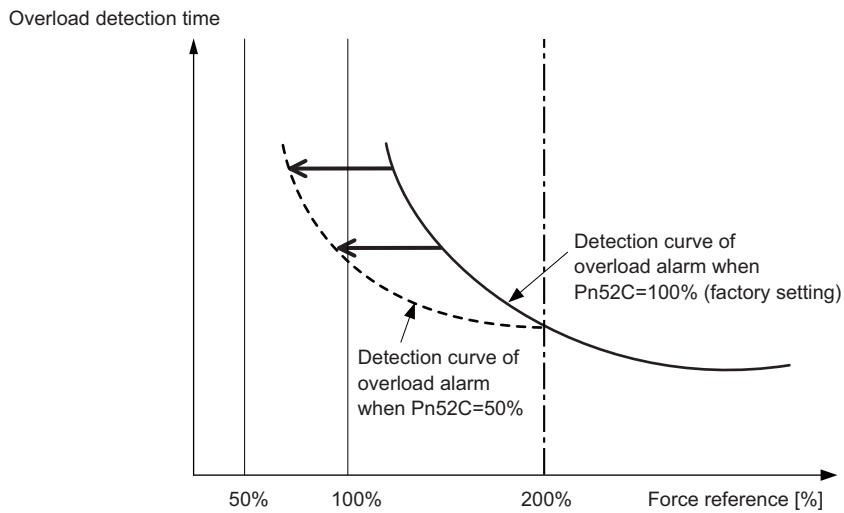

<b>Pn52C</b>	Derating of Base Current at Detecting Overload of Motor <input type="checkbox"/> Speed <input type="checkbox"/> Position <input type="checkbox"/> Force <input type="checkbox"/>				Classification
	Setting Range	Setting Unit	Factory Setting	When Enabled	
	10 to 100	1%	100	After restart	

## 4.3 Test Without Motor Function

The test without motor function is used to check the operation of the host controller and peripheral devices by simulating the operation of the linear servomotor in the SERVOPACK, i.e., without actually operating the linear servomotor. This function enables checking wiring and verifying the system and parameters when errors occur while debugging the system, thus shortening the time required for setup work and preventing damage to the equipment that may result from possible malfunctions. The operation of the linear servomotor can be checked during performing this function regardless of whether the linear servomotor is actually connected or not.

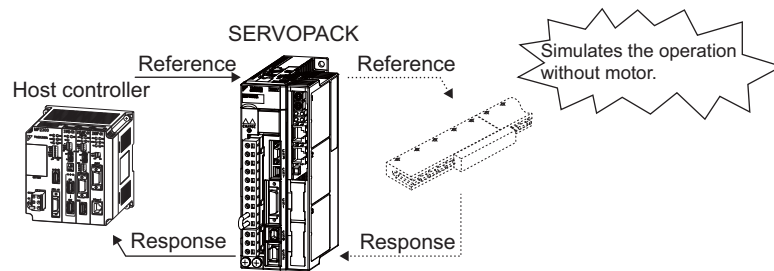

### 4.3.1 Related Parameters

The following parameters are used for the test without motor.

Parameter	Meaning	When Enabled	Classification
Pn00C	n.□□□0	After restart	Setup
	n.□□□1		
	n.□0□□		
	n.□1□□		

### 4.3.2 Limitations

The following functions cannot be used during the test without motor.

- Regeneration and dynamic brake operation
- Brake output signal (The brake output signal can be checked with the I/O signal monitor function of the SigmaWin+.)
- Items marked with “×” in the following utility function table.

If the linear scale connection cables are disconnected and then connected again during the test without a motor after having started the test with the linear scale connection cables connected, the utility functions that can be executed are limited to items marked with “○” in the “Motor not connected” column in the following utility function table.

Fn No.	Contents	Can be used or not	
		Motor not connected	Motor connected
Fn000	Alarm history display	○	○
Fn002	JOG operation	○	○
Fn003	Origin search	○	○
Fn004	Program JOG operation	○	○
Fn005	Initializing parameter settings	○	○
Fn006	Clearing alarm history	○	○
Fn008	Absolute encoder multi-turn reset and encoder alarm reset	×	○
Fn00C	Offset adjustment of analog monitor output	○	○
Fn00D	Gain adjustment of analog monitor output	○	○
Fn00E	Automatic offset-signal adjustment of motor current detection signal	×	○
Fn00F	Manual offset-signal adjustment of motor current detection signal	×	○
Fn010	Write prohibited setting	○	○
Fn011	Servomotor model display	○	○
Fn012	Software version display	○	○
Fn014	Resetting configuration error of option module	○	○
Fn01B	Vibration detection level initialization	×	×
Fn01E	Display of SERVOPACK and servomotor ID	○	○
Fn01F	Display of servomotor ID in feedback option	○	○
Fn020	Origin setting	×	○
Fn030	Software reset	○	○
Fn080	Polarity detection	×	×
Fn200	Tuning-less level setting	×	×
Fn201	Advanced autotuning	×	×
Fn202	Advanced autotuning by reference	×	×
Fn203	One-parameter tuning	×	×
Fn204	Anti-resonance control adjustment function	×	×
Fn205	Vibration suppression function	×	×
Fn206	EasyFFT	×	×
Fn207	Online vibration monitor	×	×

○: can be used

×: cannot be used

### 4.3.3 Digital Operator Display during Testing without Motor

The mark (\*) is displayed before status display to indicate the test without motor operation is in progress.

* B B	- P R M / M O N -
U n 0 0 0 =	0 0 0 0 0
U n 0 0 2 =	0 0 0 0 0
U n 0 0 8 =	0 0 0 0 0 0 0 0 0 0
U n 0 0 D =	0 0 0 0 0 0 0 0 0 0

(Example: Test without motor in progress)

Display	Status
*RUN	Power is supplied to the motor.
*BB	Power to the motor is OFF.
*P DET	Detecting the polarity.
*PT NT	Forward or reverse run is prohibited.
*P-OT	Running in the forward direction is prohibited.
*N-OT	Running in the reverse direction is prohibited.
*HBB	In hard-wire base block (safety) state.

Note: The test without motor status is not displayed during alarm occurs (A.□□□).

## 4.4 Limiting Force

The SERVOPACK provides the following three methods for limiting output force to protect the machine.

Limiting Method	Description	Reference Section
Internal force limit	Always limits force by setting the parameter.	4.4.1
External force limit	Limits force by input signal from the host controller.	4.4.2
Force limit with Command Option Module	Limits force by inputting a desired force limit command to the Command Option Module from the host controller.	Refer to the manual of the connected Command Option Module.

### 4.4.1 Internal Force Limit

This function always limits maximum output force by setting values of following parameters.

<b>Pn483</b>	Forward Force Limit <span style="float:right">Speed Position Force</span>				Classification
	Setting Range	Setting Unit	Factory Setting	When Enabled	
	0 to 800	1%	800	Immediately	Setup
<b>Pn484</b>	Reverse Force Limit <span style="float:right">Speed Position Force</span>				Classification
	Setting Range	Setting Unit	Factory Setting	When Enabled	
	0 to 800	1%	800	Immediately	Setup

The setting unit is a percentage of the motor rated force.

- Note 1. Too small a force limit setting will result in insufficient force during acceleration and deceleration.  
 2. The maximum force of the linear servomotor is used whenever the value exceeds the maximum force is set.

Trace Waveform of SigmaWin+

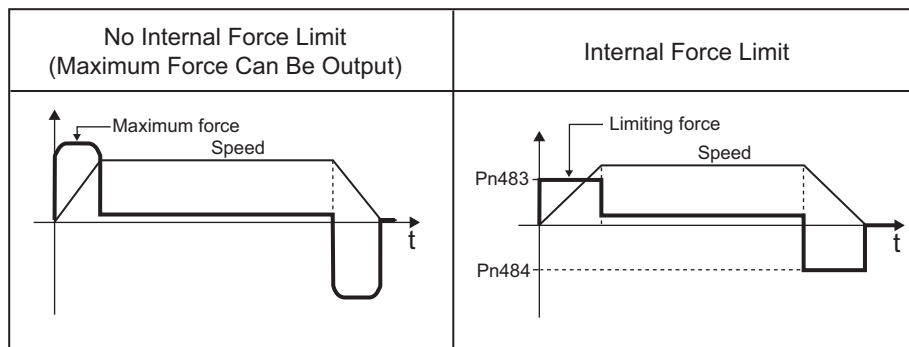

Note: The waveform reverses in case of analog monitor (CN5) output.

## 4.4.2 External Force Limit

Use this function to limit force by inputting a signal from the host controller at a specific times during machine operation, such as forced stop or hold operations for robot workpieces.

### (1) Input Signals

Type	Signal Name	Connector Pin Number	Setting	Meaning	Limit value
Input	/P-CL	Must be allocated	ON	Forward external force limit ON	The value set in Pn483 or Pn404 (whichever is smaller)
			OFF	Forward external force limit OFF	Pn483
Input	/N-CL	Must be allocated	ON	Reverse external force ON	The value set in Pn484 or Pn405 (whichever is smaller)
			OFF	Reverse external force limit OFF	Pn484

Note 1. When using external force limit, make sure that there are no other signals allocated to the same terminals as /P-CL and /N-CL. When multiple signals are allocated to the same terminal, the signals are handled with OR logic, which affects the ON/OFF state of the other signals.

2. For the allocation method, refer to 3.3.1 *Input Signal Allocations*.

### (2) Related Parameters

Set the following parameters for external force limit.

<b>Pn404</b>	Forward External Force Limit <input type="checkbox"/> Speed <input type="checkbox"/> Position <input type="checkbox"/> Force				Classification
	Setting Range	Setting Unit	Factory Setting	When Enabled	
	0 to 800	1%	100	Immediately	Setup
<b>Pn405</b>	Reverse External Force Limit <input type="checkbox"/> Speed <input type="checkbox"/> Position <input type="checkbox"/> Force				Classification
	Setting Range	Setting Unit	Factory Setting	When Enabled	
	0 to 800	1%	100	Immediately	Setup

The setting unit is a percentage of the motor rated force.

### (3) Changes in Output Force during External Force Limiting

Changes in output force when external force limit is set to 800% are shown with the waveform of Un monitor or SigmaWin+.

In this example, the linear servomotor movement direction is Pn000.0 = 0 (linear scale counting up direction = forward).

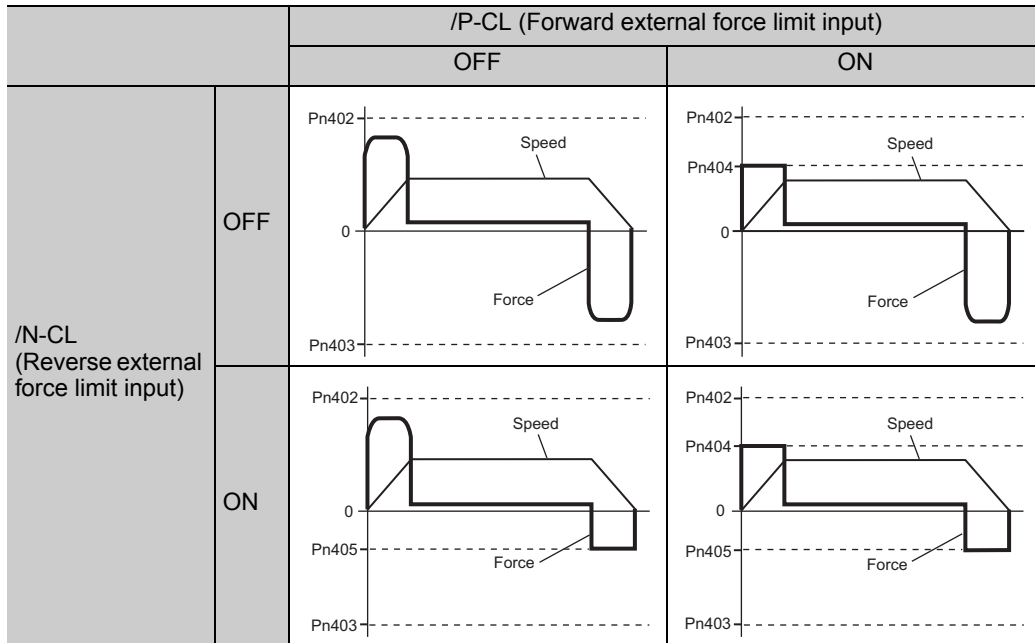

Note: The waveform reverses in case of analog monitor (CN5) output.

### 4.4.3 Checking Output Force Limiting during Operation

The following signal can be output to indicate that the linear servomotor output force is being limited.

Type	Signal Name	Connector Pin Number	Setting	Meaning
Output	/CLT	Must be allocated	ON (close)	Linear servomotor output force is being limited.
			OFF (open)	Force is not being limited.

For the allocation method, refer to 3.3.2 *Output Signal Allocation*.

## 4.5 Setting Absolute Linear Scale

The  $\Sigma$ -V SERVOPACK is compatible with an absolute linear scale.

With an absolute position system using an absolute linear scale, homing is not necessary every time the power is turned ON, so an immediate start of operation is possible.

### WARNING

- Be sure to correctly set up the absolute position system.  
Be sure to set up the system again after the system configuration is altered by changes such as the replacement of the SERVOPACK, the absolute linear scale, or any of their parts.  
Failure to observe this warning may cause the linear servomotor to overrun and may result in injury or damage to the product.

### 4.5.1 Setup Procedure

Step	Operation	Reference
1	Perform all necessary wiring and set the required safety function.	3 <i>Wiring and Connection</i>
2	Turn ON the SERVOPACK and confirm that the SERVOPACK operates correctly.	
3	Write the motor parameters and the scale constants into the absolute linear scale using the specified tool.	5 <i>Trial Operation of <math>\Sigma</math>-V series User's Manual, Setup, Linear Motor (SIEP S800000 44)</i>
4	Perform origin setting (Fn020). *1, *3	4.5.2 <i>Origin Setting (Fn020)</i>
5	Perform polarity detection (Fn080). *2, *3	4.5.3 <i>Polarity Detection (Fn080)</i>
6	Turn the power supply OFF and then ON again.	
7	Perform polarity detection (Fn080).	4.5.3 <i>Polarity Detection (Fn080)</i>

\*1. This step can be skipped in the following cases.

- After setting the origin for the absolute linear scale itself
- After replacing only the SERVOPACK

\*2. Perform this step only when the linear servomotor must move from the current position to a position that will be set as the origin after an electrical current is applied to the linear servomotor.

\*3. When using a linear scale manufactured by Magnescale Co., Ltd., this procedure is not necessary.



## 4.5.2 Origin Setting (Fn020)

This function sets the current position of linear scale as the origin when using a linear scale.

The following absolute linear scale can be used.

Environmental resistant absolute linear scale made by Mitutoyo Corporation

ABS ST780A series















Model: ABS ST78□A

### (1) Checking before Operation

Confirm the following before executing the origin setting.

- Write Prohibited Setting (Fn010) is set to permit writing.
- Servo OFF state
- Polarity Detection (Fn080) has been executed.

### (2) Operating Procedure

Step	Display after Operation	Key	Operation
1	<pre> BB      - FUNCTION - Fn01F:FBOPMotID Fn020:S-Orig Set Fn030:Soft Reset Fn080:Pole Detect           </pre>	  	Press the  Key to select the utility function main menu. And then, press the  or  Key to select Fn020.
2	<pre> BB Scale Origin Set ORGSET1           </pre>		Press the  Key. The display will be switched to the execution display of Fn020 (Origin Setting).
3	<pre> BB Scale Origin Set ORGSET5           </pre>	 or 	Press the  or  Key to select ORGSET5.
4	<pre> BB Scale Origin Set           </pre>		Press the  Key. Origin setting will start. During execution of origin setting, "Scale Origin Set" will be displayed blinking. At completion of origin setting, "Scale Origin Set" stops blinking, and "BB" in the status display field will change to "DONE."
5			Turn the SERVOPACK power supply OFF and then ON again to validate the setting.

### 4.5.3 Polarity Detection (Fn080)













The polarity detection function is used to detect the polarity and save the servomotor phase data in the SERVOPACK. After executing this function once, polarity detection is not necessary every time the power is turned ON, so an immediate start of operation is possible.

#### (1) Checking Before Operation

Confirm the following before executing the polarity detection.

- Write Prohibited Setting (Fn010) is set to permit writing.
- Servo OFF state
- Servo Ready state

#### (2) Operating Procedure

Step	Display after Operation	Key	Operation
1	<pre> BB      - FUNCTION - Fn030: Soft Reset Fn080: Pole Detect Fn200: TuneLvl Set Fn201: AAT           </pre>	  	Press the  Key to select the utility function main menu. And then, press the  or  Key to select Fn080.
2	<pre> BB Magnetic Pole Detect Start :[JOGSVON] Return:[SET]           </pre>		Press the  Key. The display will be switched to the execution display of Fn080 (Polarity Detection).
3	<pre> P DET Magnetic Pole Adjustment Return:[SET]           </pre>		Press the  Key. The power to the linear servomotor will be automatically turned ON to start the polarity detection. During execution of polarity detection, "Magnetic Pole Adjustment" is displayed blinking. When the detection is completed, the power to the linear servomotor will be automatically turned OFF.
4	<pre> BB Magnetic Pole Detect Return:[SET]           </pre>		At completion of polarity detection, the display shown on the left will appear on screen.
5	<pre> BB      - FUNCTION - Fn030: Soft Reset Fn080: Pole Detect Fn200: TuneLvl Set Fn201: AAT           </pre>		Press the  Key. The display will return to the utility function main menu.

### 4.5.4 Absolute Linear Scale Reception Sequence

The sequence in which the SERVOPACK receives outputs from the absolute linear scale and transmits them to host controller is shown below.

#### (1) Outline of Absolute Signals

The serial data, pulses, etc., of the absolute linear scale that are output from the SERVOPACK are output from the PAO, PBO, and PCO signals as shown below.

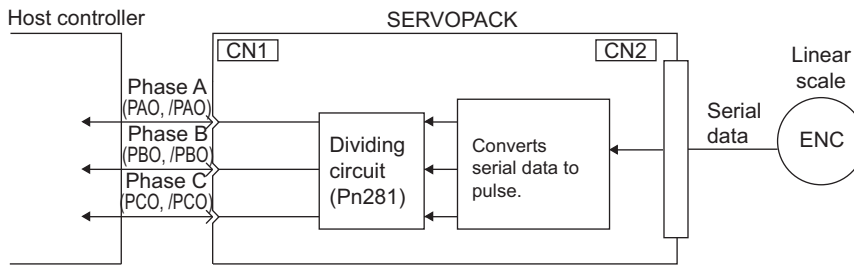

Signal Name	Status	Contents
PAO	At initialization	Serial data Initial incremental pulses
	Normal time	Incremental pulses
PBO	At initialization	Initial incremental pulses
	Normal time	Incremental pulses
PCO	Always	Origin pulses

Note: When host controller receives the data of absolute linear scale, do not perform counter reset using the output of PCO signal.

#### (2) Absolute Linear Scale Transmission Sequence and Contents

##### ■ Absolute Linear Scale Transmission Sequence

1. Send the sensor ON command from the host controller.
2. After 100 ms, set the system to serial data reception-waiting-state. Clear the incremental pulse up/down counter to zero.
3. Receive eight characters of serial data.
4. The system enters a normal incremental operation state about 400 ms after the last serial data is received.

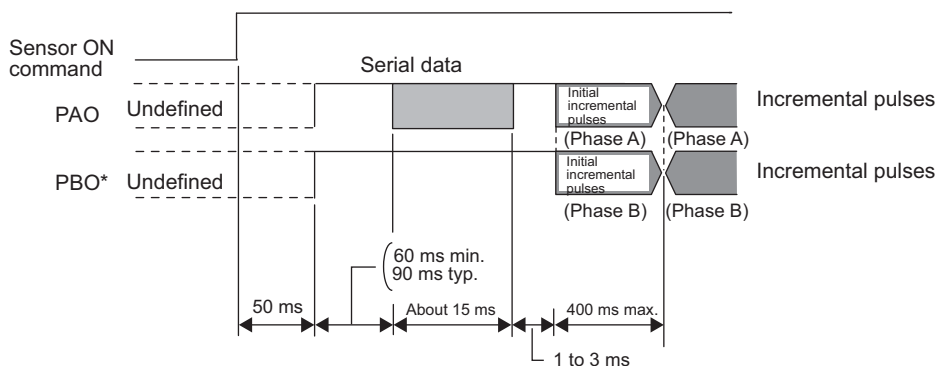

Serial data:

The current position pulses divided by Pn281 are output in serial data. One serial data is a value equivalent to 1048576 pulses.

Initial incremental pulses:

The current position pulses divided by Pn281 are output in pulses. The number of output pulses is between 0 to 1048576, and the output speed is approximately 0.37 μs per pulse.

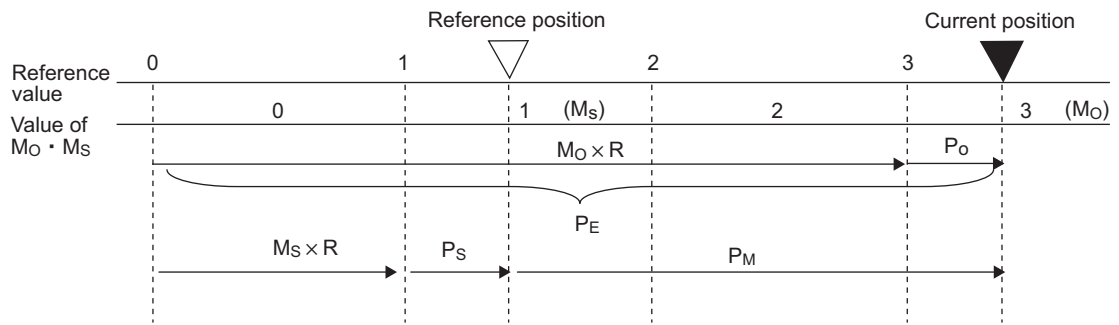

Final absolute data  $P_M$  is calculated by the following formula.

$$P_E = M_O \times R + P_O$$

$$P_M = P_E - M_S \times R - P_S$$

Note: This formula also applies for the reverse direction mode ( $Pn000.0 = 1$ ).

$P_E$	Current position of linear scale
$M_O$	Serial data of current position
$P_O$	Number of initial incremental pulses of current position
$M_S$	Serial data of reference position
$P_S$	Number of initial incremental pulses of reference position
$P_M$	Current position required for the user's system
R	1048576

Note: When host controller receives the data of absolute linear scale, do not perform counter reset using the output of PCO signal.

### (3) Detailed Signal Specifications

The detailed signal specifications are shown below.

#### ■ PAO Serial Data Specifications.

Data Transfer Method	Start-stop Synchronization (ASYNC)
Baud rate	9600 bps
Start bits	1 bit
Stop bits	1 bit
Parity	Even
Character code	ASCII 7-bit code
Data format	8 characters, as shown below. 

Note 1. The absolute data range is "P+00000" (CR) or "P-00000" (CR).  
 Note 2. The serial data range is "+32767" to "-32768." When this range is exceeded, the data changes from "+32767" to "-32768" or from "-32768" to "+32767."  
 Note 3. The signs are inversed when in reverse direction mode (Pn000.0 = 1).

### (4) Transferring Alarm Contents

If an absolute linear scale is used, the contents of alarms detected by the SERVOPACK can be transmitted in serial data to the host controller from the PAO output when the sensor ON command is changed from ON to OFF.

Note: Sensor ON command cannot be received during Servo ON.

An example of alarm contents output is shown below.

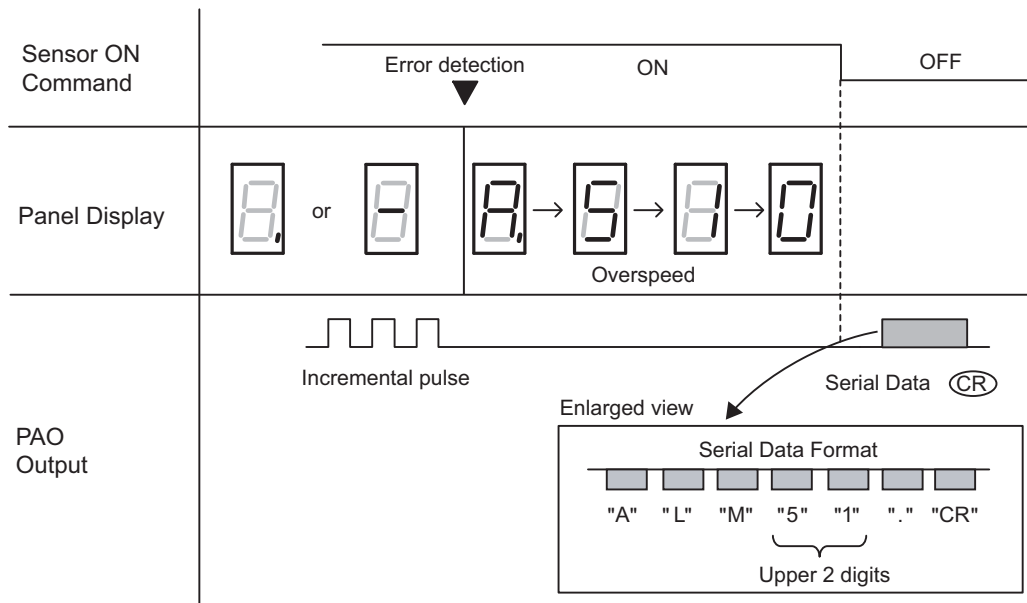

## 4.6 Other Output Signals

This section explains other output signals that are not directly related to any specific control mode.

Use these signals according to the application needs, e.g., for machine protection.

### 4.6.1 Servo Alarm Output Signal (ALM)

This section describes the ALM signal that is output when the SERVOPACK detects errors and how to reset the alarm.

#### (1) Servo Alarm Output Signal (ALM)

This signal is output when the SERVOPACK detects errors.

 <b>IMPORTANT</b>	Configure an external circuit so that this alarm output turns OFF the main circuit power supply for the SERVOPACK whenever an error occurs.
---	---

Type	Signal Name	Connector Pin Number	Setting	Meaning
Output	ALM	CN1--31, -32	ON (close)	Normal SERVOPACK status
			OFF (open)	SERVOPACK alarm status

#### (2) Alarm Reset Methods

For information on how to reset the servo alarm (ALM), refer to the manual of the connected Command Option Module.

 <b>IMPORTANT</b>	Be sure to eliminate the cause before resetting the alarm.
---	--

#### ■ Resetting Alarms from the Host Controller through the Command Option Module

For this method, refer to the manual of the connected Command Option Module.

#### ■ Resetting Alarms Using the Digital Operator

Press the ALARM RESET Key on the digital operator. (Refer to *ΣV Series User's Manual: Operation of Digital Operator* (SIEP S800000 55).)

### 4.6.2 Warning Output Signal (/WARN)

This signal is output at occurrence of overload warning (A.910) or regenerative overload warning (A.920) that may lead to occurrence of overload alarm (A.710) or regenerative overload alarm (A.320). Refer to 8.2.1 *List of Warnings*.

#### (1) Signal Specifications

Type	Signal Name	Connector Pin Number	Setting	Meaning
Output	/WARN	Must be allocated	ON (close)	Warning status
			OFF (open)	Normal status

Note: The /WARN signal must be allocated. For details, refer to 3.3.2 *Output Signal Allocation*.

### 4.6.3 Movement Detection Output Signal (/TGON)

This output signal indicates that the linear servomotor is moving at the speed set for Pn581 or a higher speed.

The status of the signal can be checked with the panel operator or digital operator.

 <b>IMPORTANT</b>	<p>If the movement detection signal (/TGON) and the brake signal (/BK) are allocated to the same output terminal, the signal is output with OR logic. Therefore, the /TGON signal will be turned ON (low level) by the falling speed on a vertical axis, and the /BK signal will be turned OFF (high level).</p> <p>Always allocate the /TGON signal and /BK signal to different terminals.</p>
---	---

#### (1) Signal Specifications

Type	Signal Name	Connector Pin Number	Setting	Meaning
Output	/TGON	CN1-27, 28 [Factory setting]	ON (close)	Linear servomotor is moving (motor speed is above the setting in Pn581.)
			OFF (open)	Linear servomotor is moving (motor speed is below the setting in Pn581.)

The /TGON signal can be allocated to another output terminal using Pn50E. For details, refer to 3.3.2 *Output Signal Allocation*.

#### (2) Related Parameters

Set the range in which the /TGON signal is output using the following parameter.

Pn581	Zero Speed Level				Classification
	Setting Range	Setting Unit	Factory Setting	When Enabled	
	1 to 10000	1 mm/s	20	Immediately	Setup

### 4.6.4 Servo Ready Output Signal (/S-RDY)

This signal turns ON when the SERVOPACK is ready to accept the servo ON signal.

This signal is output under the following conditions.

- The main circuit power supply is ON.
- A hard wire base block is not applied.
- No servo alarm occurs.
- The polarity detection has been completed.

For details on the hard wire base block function, refer to 4.7.1 *Hard Wire Base block (HWBB) Function*.

Note: When using an absolute linear scale, the following condition must also be satisfied.

The sensor ON command has been input and the absolute data has been output to the host controller.

#### (1) Signal Specifications

Type	Signal Name	Connector Pin Number	Setting	Meaning
Output	/S-RDY	CN1-29, 30 [Factory setting]	ON (close)	Ready to accept the servo ON command.
			OFF (open)	Not ready to accept the servo ON command.

- The /S-RDY signal can be allocated to another output terminal using Pn50E. For details, refer to 3.3.2 *Output Signal Allocation*.
- For details on the hard wire base block function and the servo ready output signal, refer to 4.7.1 *Hard Wire Base Block (HWBB) Function*.

## 4.7 Safety Function

The safety function is incorporated in the SERVOPACK to reduce the risk associated with the machine by protecting workers from injury and by securing safe machine operation. Especially when working in hazardous areas inside the safeguard, as for machine maintenance, it can be used to avoid adverse machine movement.

### 4.7.1 Hard Wire Base Block (HWBB) Function

The hard wire base block function (hereinafter referred to as HWBB function) is a safety function designed to shut off the motor current by using the hard wired circuits: Each circuit for two channel input signals blocks the run signal to turn off the power module, and the motor current is shut off. (Refer to the diagram below.)

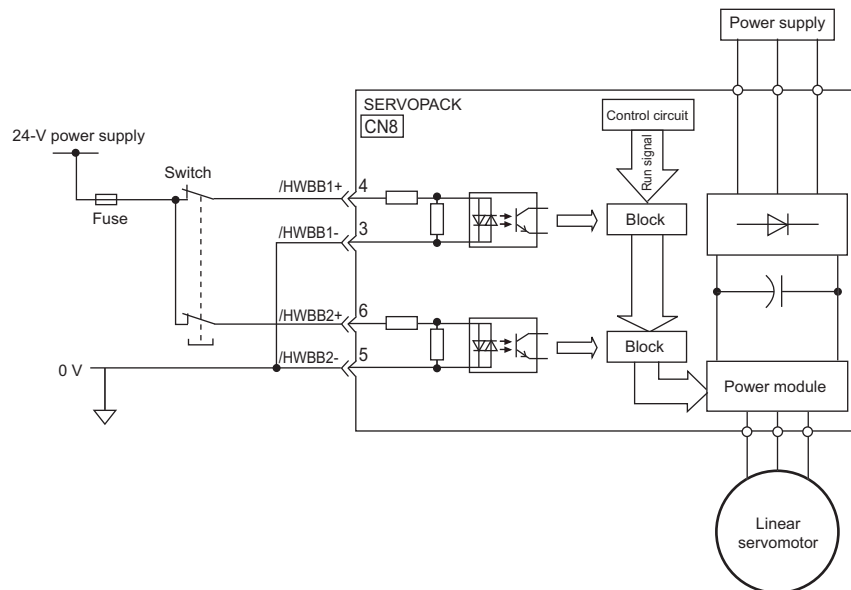

Note: For safety function signal connections, the input signal is the 0V common and the output signal is the source output. This is opposite to other signals described in this manual. To avoid confusion, the ON and OFF status of signals for safety functions are defined as follows:

ON: The state in which the relay contacts are closed or the transistor is ON and current flows into the signal line.

OFF: The state in which the relay contacts are open or the transistor is OFF and no current flows into the signal line.

#### (1) Risk Assessment

Perform risk assessment for the system and confirm that the safety requirements with the following standards are fulfilled before using the HWBB function.

EN954-1 Category3  
IEC61508-1 to 4 SIL2

The following risks can be estimated even if the HWBB function is used. These risks must be included in the risk assessment.

- The motor will move in an application where external force is applied to the motor (for example, gravity on the vertical axis). Take measures to secure the motor, such as installing a mechanical brake.
- The motor may move within the electric angle of 180 degrees in case of the power module failure, etc. Make sure to take the proper measures to ensure safety when the motor starts to move. The number of travel distance depends on the motor type as shown below.
  - Rotational servomotor: 1/6 rotation max. (rotation angle at the motor shaft)
  - Direct-drive motor: 1/20 rotation max. (rotation angle at the motor shaft)
  - Linear servomotor: 30 mm max.
- The HWBB function does not shut off the power to the SERVOPACK or electrically isolate it. Take measures to shut off the power to the SERVOPACK when performing maintenance on it, etc.



## (2) Hard Wire Base Block (HWBB) State

The SERVOPACK will be in the following state if the HWBB function operates. If the /HWBB1 or /HWBB2 signal is OFF, the HWBB function will operate and the SERVOPACK will enter a hard wire base block (HWBB) state.

The HWBB function operates after the linear servomotor power is turned OFF.

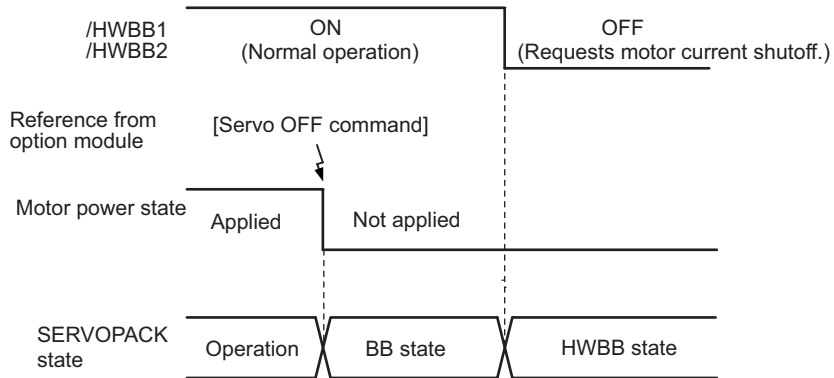

The HWBB function operates during the linear servomotor operation.

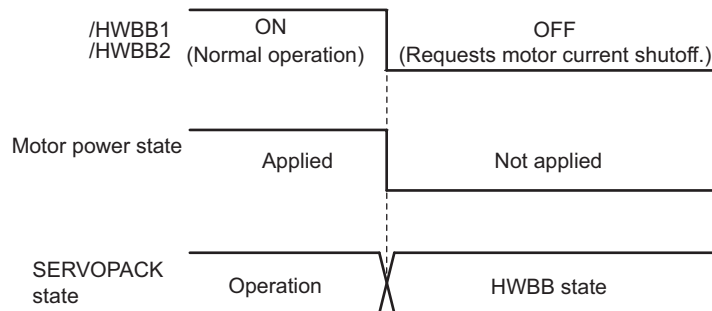

### (3) Resetting the HWBB State

By receiving a servo ON command again after both /HWBB1 and /HWBB2 signals are turned ON, the SERVOPACK returns to normal operation status. Refer to the manual of the connected option module for details on servo ON/OFF commands.

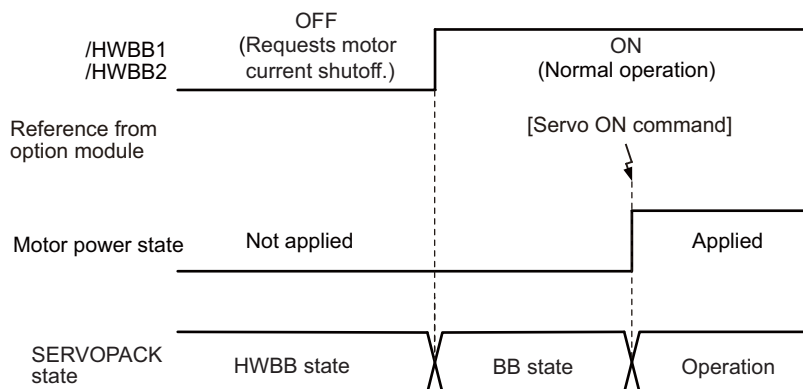

To return to normal operation status:

If a servo ON command has been sent while the SERVOPACK is in the HWBB status,

1. Turn on both /HWBB1 and /HWBB2 signals.
2. Send any command other than a servo ON command, such as a servo OFF command, to change the status of the SERVOPACK from a hard wire base block (HWBB) to a base block (BB).
3. Resend a servo ON command.

Note: Even if the linear servomotor power is turned OFF by turning OFF the main circuit power, the HWBB status is retained until a servo OFF command is input.

### (4) Error Detection in HWBB Signal

If only the /HWBB1 or /HWBB2 signal is input, an A.Eb1 alarm (Safety Function Signal Input Timing Error) will occur unless the other signal is input within 10 seconds. This makes it possible to detect failures, such as disconnection of the HWBB signals.

#### ⚠ CAUTION

- The A.Eb1 alarm (Safety Function Signal Input Timing Error) is not related to the safety function. Keep this in mind in the system design.

### (5) Connection Example and Specifications of Input Signals (HWBB Signals)

The input signals must be redundant. A connection example and specifications of input signals (HWBB signals) are shown below.



**IMPORTANT**

For safety function signal connections, the input signal is the 0V common and the output signal is the source output. This is opposite to other signals described in this manual. To avoid confusion, the ON and OFF status of signals for safety functions are defined as follows:

**ON:** The state in which the relay contacts are closed or the transistor is ON and current flows into the signal line.

**OFF:** The state in which the relay contacts are open or the transistor is OFF and no current flows into the signal line.

#### ■ Connection Example

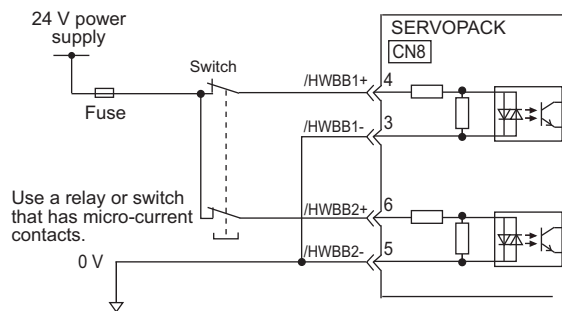

#### ■ Specifications

Type	Signal Name	Pin Number	State	Meaning
Input	/HWBB1	CN8-4	ON	Does not use the HWBB function.
		CN8-3	OFF	Uses the HWBB function.
	/HWBB2	CN8-6	ON	Does not use the HWBB function.
		CN8-5	OFF	Uses the HWBB function.

The input signals (HWBB signals) have the following electrical characteristics.

Items	Characteristics	Remarks
Internal impedance	3.3 kΩ	—
Operation movable voltage range	+11 V to + 25 V	—
Maximum delay time	20 ms	Time from when the /HWBB1 and /HWBB2 signals are OFF to when the HWBB function operates.

If the HWBB function is requested by turning OFF the /HWBB1 and /HWBB2 input signals on the two channels, power supply to the linear servomotor will be turned OFF within 20 ms (see below).

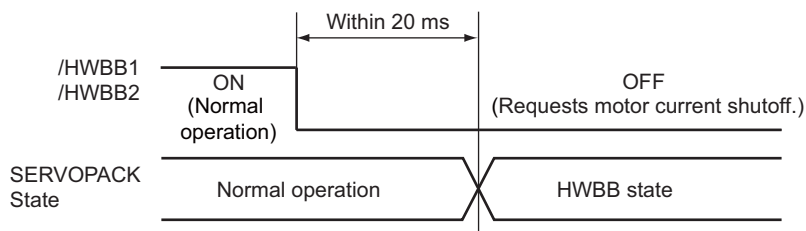

Note: The OFF status is not recognized when the /HWBB1 and /HWBB2 signals are OFF for 0.5 ms or shorter.

## (6) Operation with Utility Functions

The HWBB function works while the SERVOPACK operates in utility function mode.

If any of the following utility functions is being used with the /HWBB1 and /HWBB2 signals turned OFF, the SERVOPACK cannot be operated by turning ON the /HWBB1 and /HWBB2 signals. Cancel the utility function first, and then set the SERVOPACK to the utility function mode again and restart operation.

- JOG operation (Fn002)
- Origin search (Fn003)
- Program JOG operation (Fn004)
- Advanced autotuning (Fn201)
- EasyFFT (Fn206)
- Automatic offset-signal adjustment of motor current detection signal (Fn00E)

## (7) Servo Ready Output (/S-RDY)

The servo ON command will not be accepted in the HWBB state. Therefore, the servo ready output will turn OFF.

The servo ready output will turn ON if the servo OFF command is input when both the /HWBB1 and /HWBB2 signals are ON.

The following diagram shows an example where the main circuit power is turned ON and no servo alarm occurs.

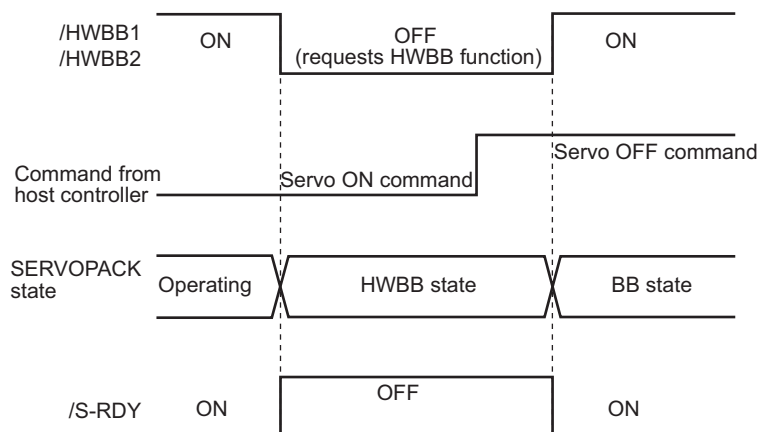

## (8) Brake Signal (/BK)

When the /HWBB1 or /HWBB2 signal is OFF and the HWBB function operates, the brake signal (/BK) will turn OFF. At that time, Pn506 (Brake Reference - Servo OFF Delay Time) will be disabled. Therefore, the linear servomotor may be moved by external force until the actual brake becomes effective after the brake signal (/BK) turns OFF.

Note: The brake signal output is not related to safety functions. Be sure to design the system so that the system will not be put into danger if the brake signal fails in the HWBB state.

## (9) Dynamic Brake

If the dynamic brake is enabled in Pn001.0 (Servomotor Power OFF or Alarm Gr.1 Stop Mode), the linear servomotor will come to a stop under the control of the dynamic brake when the HWBB function works while the /HWBB1 or /HWBB2 signal is OFF.

Note: The dynamic brake is not related to safety function. Be sure to design the system so that the system will not be put into danger if the linear servomotor coasts to a stop in the HWBB state. Usually, use a sequence in which the HWBB state occurs after the linear servomotor is stopped using a command.



### CAUTION

If the application frequently uses the HWBB function, do not use the dynamic brake to stop the linear servomotor, or otherwise element deterioration in the SERVOPACK may result. Use a sequence in which the HWBB state occurs after the linear servomotor has come to a stop.

### (10) Servo Alarm Output Signal (ALM)

In the HWBB state, the servo alarm output signal (ALM) is not output.

## 4.7.2 External Device Monitor (EDM1)

The external device monitor (EDM1) functions to monitor failures in the HWBB function. Connect the monitor to feedback signals to the safety unit. The relation of the EDM1, /HWBB1, and /HWBB2 signals is shown below.

Signal Name	Logic			
/HWBB1	ON	ON	OFF	OFF
/HWBB2	ON	OFF	ON	OFF
EDM1	OFF	OFF	OFF	ON

### ■ Failure Detection Signal for EDM1 Signal

The status of the EDM1 signal indicates if a failure was detected in the EDM1 circuit or not, and is determined by the status of the /HWBB1 and /HWBB2 signals as shown in this table. If the signal status differs from those shown here, a failure has occurred in the EDM1 circuit. Failures can be detected if the failure status can be confirmed, such as when the power supply is turned ON.



## WARNING

The EDM1 signal is not a safety output. Use it only for monitoring a failure.

### (1) Connection Example and Specifications of EDM1 Output Signal

Connection example and specifications of EDM1 output signal are explained below.



**IMPORTANT**

For safety function signal connections, the input signal is the 0V common and the output signal is the source output. This is opposite to other signals described in this manual. To avoid confusion, the ON and OFF status of signals for safety functions are defined as follows:

**ON:** The state in which the relay contacts are closed or the transistor is ON and current flows into the signal line.

**OFF:** The state in which the relay contacts are open or the transistor is OFF and no current flows into the signal line.

#### ■ Connection Example

EDM1 output signal is used for source circuit.

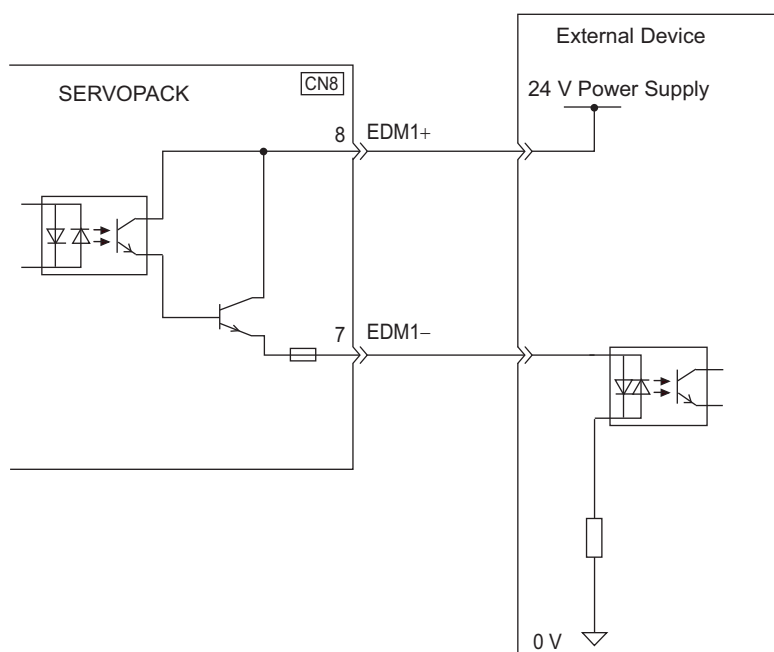

#### ■ Specifications

Type	Signal Name	Pin No.	State	Meaning
Output	EDM1	CN8-8 CN8-7	ON	The /HWBB1 signal and /HWBB2 signal are both operating normally.
			OFF	Both the /HWBB1 signal and /HWBB2 signal are not operating normally or either of the two is not operating normally.

Electrical characteristics of EDM1 signal are as follows.

Items	Characteristics	Remarks
Maximum Allowable Voltage	30 VDC	—
Maximum Current	50 mADC	—
Maximum Voltage Drop at ON	1.0 V	Voltage between EDM1+ to EDM1- when the current is 50 mA.
Maximum Delay Time	20 ms	Time from change of /HWBB1, /HWBB2 to change of EDM1

### 4.7.3 Application Example of Safety Functions

An example of using safety functions is shown below.

#### (1) Connection Example

In the following example, a safety unit is used and the HWBB function operates when the guard opens.

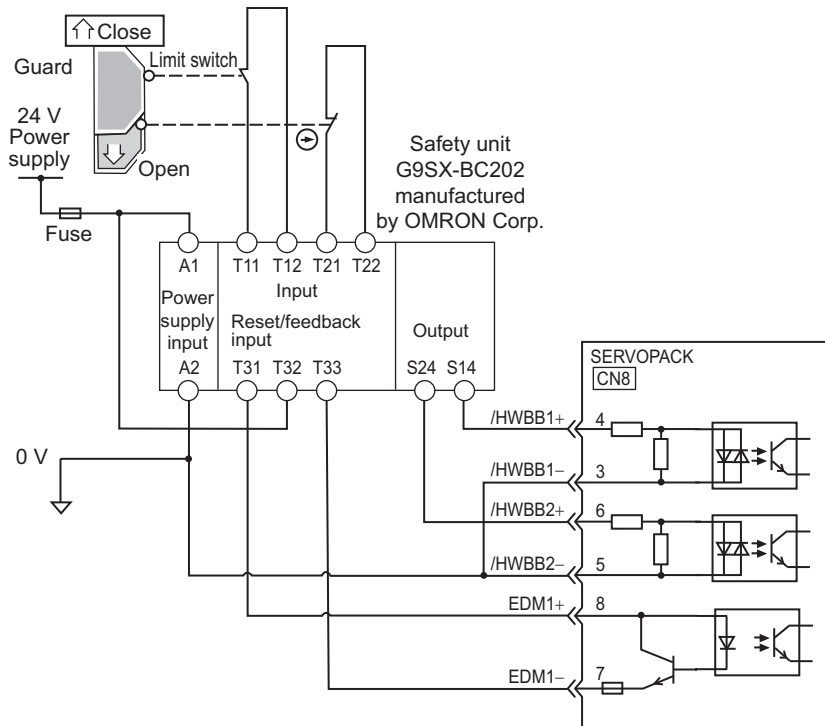

When a guard opens, both of signals, the /HWBB1 and the /HWBB2, turn OFF, and the EDM1 signal is ON. Since the feedback circuit is ON when the guard closes, the safety unit is reset, and the /HWBB1 and the /HWBB2 signals turn ON, and the operation becomes possible.

Note: Connect the EDM1 as the direction of current flows from EDM1+ to EDM1-, because the EDM1 has polarity with a transistor output.

#### (2) Failure Detection Method

In case of a failure such as the /HWBB1 or the /HWBB2 signal remains ON, the safety unit is not reset because the EDM1 signal keeps OFF. Therefore starting is impossible, then the failure is detected.

An error in the external device, disconnection or short-circuiting of the external wiring, or a failure in the SERVOPACK must be considered. Find the cause and correct the problem.

## (3) Usage Example

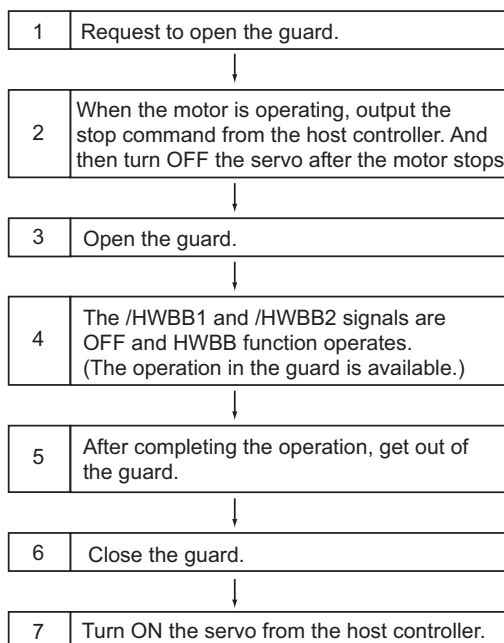
**4.7.4** Confirming Safety Functions

When starting the equipment or replacing the SERVOPACK for maintenance, be sure to conduct the following confirmation test on the HWBB function after wiring.

- When the /HWBB1 and/or /HWBB2 signals turn OFF, check that the digital operator displays “Hbb” and that the linear servomotor does not operate.
- Check the ON/OFF states of the /HWBB1 and /HWBB2 signals with bits 0 and 1 of Un015.  
→ If the ON/OFF states of the signals do not coincide with the display, an error in the external device, disconnection or short-circuiting of the external wiring, or a failure in the SERVOPACK must be considered. Find the cause and correct the problem.
- Check with the display of the feedback circuit input of the connected device to confirm that the EDM1 signal is OFF while in normal operation.



### 4.7.5 Connecting a Safety Device

Connect a safety device using the following procedure.

1. Remove the linear servomotor connection terminal block while pressing the lock.

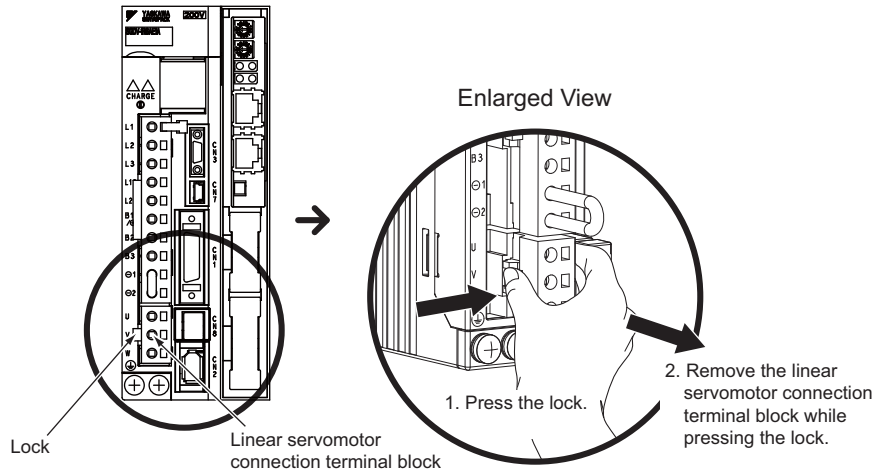

2. Slide the lock injector of the safety function jumper connector to the SERVOPACK side to unlock and remove the safety function jumper connector.

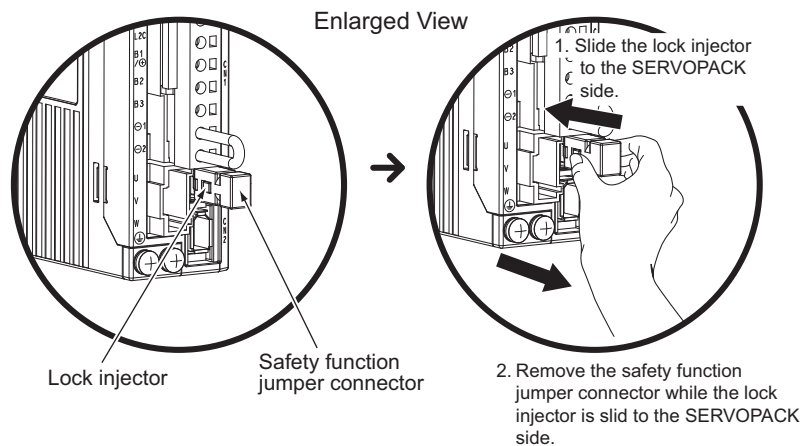

Note: The safety function jumper connector may be damaged if it is removed without being unlocking.

3. Connect a safety device to CN8.

Note: When not using the safety function, use the SERVOPACK with the safety function jumper connector (JZSP-CVH05-E provided as an accessory) inserted in CN8. If the SERVOPACK is used without the jumper connector inserted into CN8, no current will flow to the linear servomotor and no force will be output. In this case, “Hbb” will be displayed on the digital operator.

## 4.7.6 Precautions for Safety Functions

### WARNING

- To check that the HWBB function satisfies the safety requirements of the system, be sure to conduct a risk assessment of the system.  
Incorrect use of the machine may cause injury.
- The linear servomotor moves if there is external force (e.g., gravity in a vertical axis) when the HWBB function is operating. Therefore, use an appropriate device independently, such as a mechanical brake, that satisfies safety requirements.  
Incorrect use of the machine may cause injury.
- While the HWBB function is operating, the linear servomotor may move within an electric angle of 180° or less as a result of a SERVOPACK failure. Use the HWBB function for applications only after checking that the movement of the linear servomotor will not result in a dangerous condition.  
Incorrect use of the machine may cause injury.
- The dynamic brake and the brake signal are not related to safety functions. Be sure to design the system that these failures will not cause a dangerous condition when the HWBB function operates.  
Incorrect use of the machine may cause injury.
- The SERVOPACK with its signals for a safety function must be connected to a device that meets safety standards.  
Incorrect use of the machine may cause injury.
- If the HWBB function is used for an emergency stop, turn OFF the power supply to the linear servomotor with independent electric or mechanical parts.  
Incorrect use of the machine may cause injury.
- The HWBB function does not turn OFF the power supply to the SERVOPACK or electrically isolate the SERVOPACK. When maintaining the SERVOPACK, be sure to turn OFF the power supply to the SERVOPACK independently.  
Failure to observe this warning may cause an electric shock.

## Adjustments

5.1 Adjustments and Basic Adjustment Procedure	5-3
5.1.1 Adjustments	5-3
5.1.2 Basic Adjustment Procedure	5-4
5.1.3 Monitoring Analog Signals	5-5
5.1.4 Safety Precautions on Adjustment of Servo Gains	5-8
5.2 Tuning-less Function	5-10
5.2.1 Tuning-less Function	5-10
5.2.2 Tuning-less Levels Setting (Fn200) Procedure	5-13
5.3 Advanced Autotuning (Fn201)	5-16
5.3.1 Advanced Autotuning	5-16
5.3.2 Advanced Autotuning Procedure	5-19
5.3.3 Related Parameters	5-24
5.4 Advanced Autotuning by Reference (Fn202)	5-25
5.4.1 Advanced Autotuning by Reference	5-25
5.4.2 Advanced Autotuning by Reference Procedure	5-27
5.4.3 Related Parameters	5-31
5.5 One-parameter Tuning (Fn203)	5-32
5.5.1 One-parameter Tuning	5-32
5.5.2 One-parameter Tuning Procedure	5-33
5.5.3 One-parameter Tuning Example	5-39
5.5.4 Related Parameters	5-40
5.6 Anti-resonance Control Adjustment Function (Fn204)	5-41
5.6.1 Anti-resonance Control Adjustment Function	5-41
5.6.2 Anti-resonance Control Adjustment Function Operating Procedure	5-42
5.6.3 Related Parameters	5-46
5.7 Vibration Suppression Function (Fn205)	5-47
5.7.1 Vibration Suppression Function	5-47
5.7.2 Vibration Suppression Function Operating Procedure	5-48
5.7.3 Related Parameters	5-51

<b>5.8 Additional Adjustment Function</b> .....	<b>5-52</b>
5.8.1 Switching Gain Settings .....	5-52
5.8.2 Friction Compensation .....	5-57
5.8.3 Current Control Mode Selection .....	5-59
5.8.4 Current Gain Level Setting .....	5-59
5.8.5 Speed Detection Method Selection .....	5-59
<b>5.9 Compatible Adjustment Function</b> .....	<b>5-60</b>
5.9.1 Feedforward Reference .....	5-60
5.9.2 Using the Mode Switch (P/PI Switching) .....	5-60
5.9.3 Force Reference Filter .....	5-65
5.9.4 Position Integral Time Constant .....	5-67

## 5.1 Adjustments and Basic Adjustment Procedure

This section describes adjustments and the basic adjustment procedure.

### 5.1.1 Adjustments

Tuning is performed to optimize the responsiveness of the SERVOPACK.

The responsiveness is determined by the servo gain that is set in the SERVOPACK.

The servo gain is set using a combination of parameters such as speed loop gain, position loop gain, filters, friction compensation, and mass ratio. These parameters influence each other. Therefore, the servo gain must be set considering the balance between the set values.

Generally, the responsiveness of a machine with high rigidity can be improved by increasing the servo gain. If the servo gain of a machine with low rigidity is increased, however, the machine will vibrate and the responsiveness may not be improved. In such cases, it is possible to suppress the vibration with a variety of vibration suppression functions in the SERVOPACK.

The servo gains are factory-set to stable values. The following utility function can be used to adjust the servo gain to increase the responsiveness of the machine in accordance with the actual conditions. With this function, these parameters will be adjusted automatically and the need to adjust them individually will be eliminated.

This section describes the following utility adjustment functions.

Utility Function for Adjustment	Outline	Applicable Control Mode
Tuning-less Level Setting (Fn200)	This function is enabled when the factory settings are used. This function can be used to obtain a stable response regardless of the type of machine or changes in the load.	Speed and Position
Advanced Autotuning (Fn201)	The following parameters are automatically adjusted using internal references in the SERVOPACK during automatic operation. <ul style="list-style-type: none"> <li>• Mass ratio</li> <li>• Gains (position loop gain, speed loop gain, etc.)</li> <li>• Filters (force reference filter, notch filter)</li> <li>• Friction compensation</li> <li>• Anti-resonance control adjustment function</li> <li>• Vibration suppression</li> </ul>	Speed and Position
Advanced Autotuning by Reference (Fn202)	The following parameters are automatically adjusted with the position reference input from the host controller while the machine is in operation. <ul style="list-style-type: none"> <li>• Gains (position loop gain, speed loop gain, etc.)</li> <li>• Filters (force reference filter, notch filter)</li> <li>• Friction compensation</li> <li>• Anti-resonance control adjustment function</li> <li>• Vibration suppression</li> </ul>	Position
One-parameter Tuning (Fn203)	The following parameters are automatically adjusted with the position, speed reference input from the host controller while the machine is in operation. <ul style="list-style-type: none"> <li>• Gains (position loop gain, speed loop gain, etc.)</li> <li>• Filters (force reference filter, notch filter)</li> <li>• Friction compensation</li> <li>• Anti-resonance control adjustment function</li> </ul>	Speed and Position
Anti-resonance Control Adjustment Function (Fn204)	This function effectively suppresses continuous vibration.	Speed and Position
Vibration Suppression Function (Fn205)	This function effectively suppresses residual vibration if it occurs when positioning.	Position

## 5.1.2 Basic Adjustment Procedure

The basic adjustment procedure is shown in the following flowchart. Make suitable adjustments considering the conditions and operating requirements of the machine.

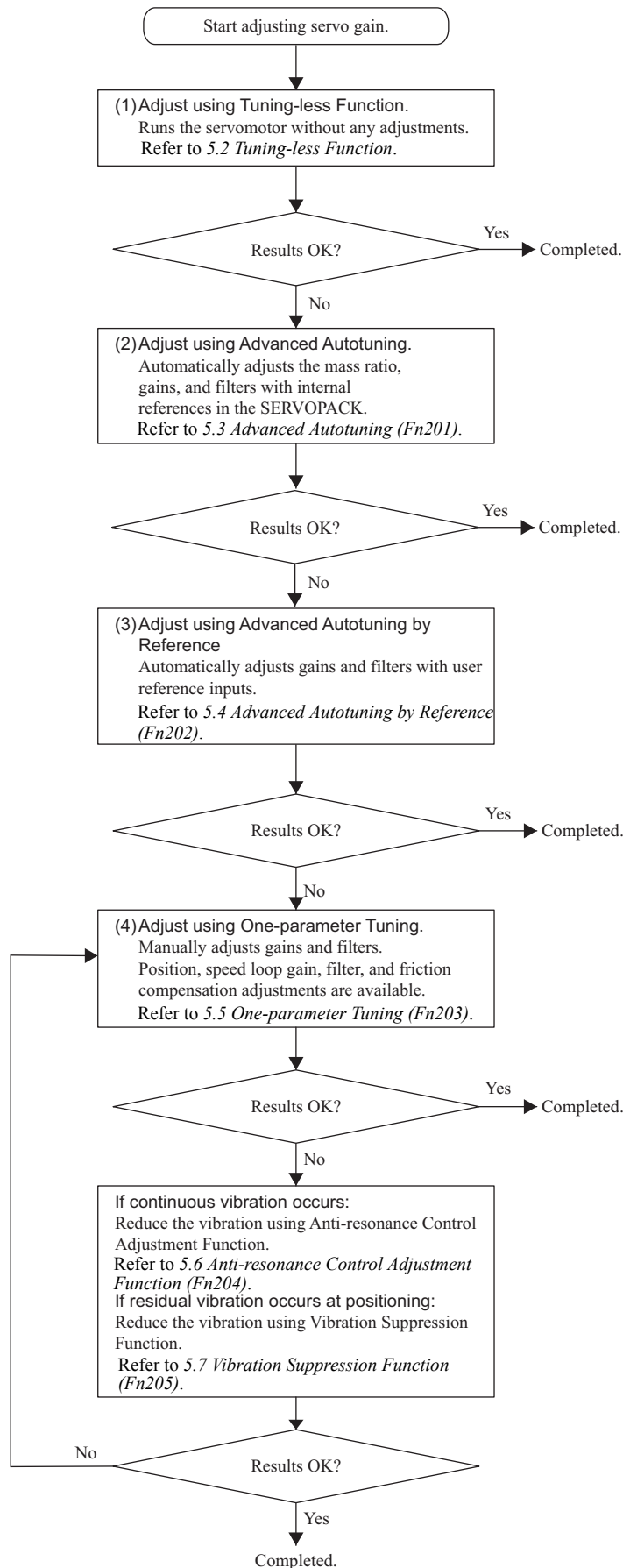

### 5.1.3 Monitoring Analog Signals

Check the operating status and signal waveform when adjusting the servo gain. Connect a measuring instrument, such as a memory recorder, to connector CN5 on the SERVOPACK to monitor analog signal waveform.

The settings and parameters for monitoring analog signals are described in the following sections.

#### (1) Monitor Signal

The analog signals that can be monitored are shaded in the following diagram.

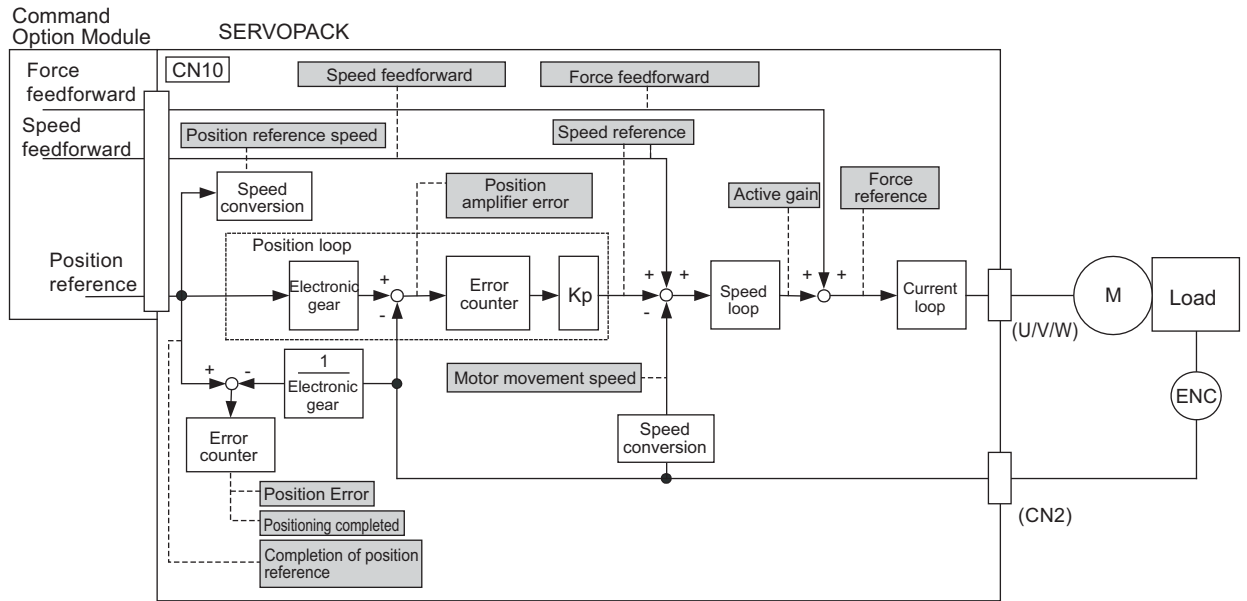

The following signals can be monitored by selecting functions of parameters Pn006 and Pn007. Pn006 is used for analog monitor 1 and Pn007 is used for analog monitor 2.

Parameter	Description		
	Monitor Signal	Measurement Gain	Remarks
Pn006 Pn007	n.□□00	Motor speed	1 V/1000 mm/s Pn007 Factory Setting
	n.□□01	Speed reference	1 V/1000 mm/s -
	n.□□02	Force reference	1 V/100% rated force Pn006 Factory Setting
	n.□□03	Position error	0.05 V/reference unit 0 V at speed/force control
	n.□□04	Position amplifier error	0.05 V/encoder pulse unit Position error after electronic gear conversion
	n.□□05	Position reference speed	1 V/1000 mm/s -
	n.□□06	Reserved (Do not change.)	- -
	n.□□07	Reserved (Do not change.)	- -
	n.□□08	Positioning completed	Positioning completed: 5 V Positioning not completed: 0 V -
	n.□□09	Speed feedforward	1 V/1000 mm/s -
	n.□□0A	Force feedforward	1 V/100% rated force -
	n.□□0B	Active gain	1st gain: 1 V 2nd gain: 2 V -
	n.□□0C	Completion of position reference	Completed: 5 V Not completed: 0 V -
	n.□□0D	Reserved (Do not change.)	- -

**(2) Setting Monitor Factor**

The output voltages on analog monitor 1 and 2 are calculated by the following equations.

$$\text{Analog monitor 1 output voltage} = (-1) \times \left( \begin{array}{c} \text{Signal selection} \\ (\text{Pn006}=\text{n.00}\square\square) \end{array} \times \begin{array}{c} \text{Multiplier} \\ (\text{Pn552}) \end{array} + \begin{array}{c} \text{Offset voltage [V]} \\ (\text{Pn550}) \end{array} \right)$$

$$\text{Analog monitor 2 output voltage} = (-1) \times \left( \begin{array}{c} \text{Signal selection} \\ (\text{Pn007}=\text{n.00}\square\square) \end{array} \times \begin{array}{c} \text{Multiplier} \\ (\text{Pn553}) \end{array} + \begin{array}{c} \text{Offset voltage [V]} \\ (\text{Pn551}) \end{array} \right)$$

**(3) Related Parameters**

Use the following parameters to change the monitor factor and the offset.

<b>Pn550</b>	Analog Monitor 1 Offset Voltage <input type="checkbox"/> Speed <input type="checkbox"/> Position <input type="checkbox"/> Force <input type="checkbox"/>				Classification
	Setting Range	Setting Unit	Factory Setting	When Enabled	
	-10000 to 10000	0.1 V	0	Immediately	Setup
<b>Pn551</b>	Analog Monitor 2 Offset Voltage <input type="checkbox"/> Speed <input type="checkbox"/> Position <input type="checkbox"/> Force <input type="checkbox"/>				Classification
	Setting Range	Setting Unit	Factory Setting	When Enabled	
	-10000 to 10000	0.1 V	0	Immediately	Setup
<b>Pn552</b>	Analog Monitor Magnification (×1) <input type="checkbox"/> Speed <input type="checkbox"/> Position <input type="checkbox"/> Force <input type="checkbox"/>				Classification
	Setting Range	Setting Unit	Factory Setting	When Enabled	
	-10000 to 10000	0.01 times	100	Immediately	Setup
<b>Pn553</b>	Analog Monitor Magnification (×1) <input type="checkbox"/> Speed <input type="checkbox"/> Position <input type="checkbox"/> Force <input type="checkbox"/>				Classification
	Setting Range	Setting Unit	Factory Setting	When Enabled	
	-10000 to 10000	0.01 times	100	Immediately	Setup



### (4) Connector CN5 for Analog Monitor

To monitor analog signals, connect a measuring instrument with cable (JZSP-CA01-E) to the connector CN5.

#### ■ Connection Example

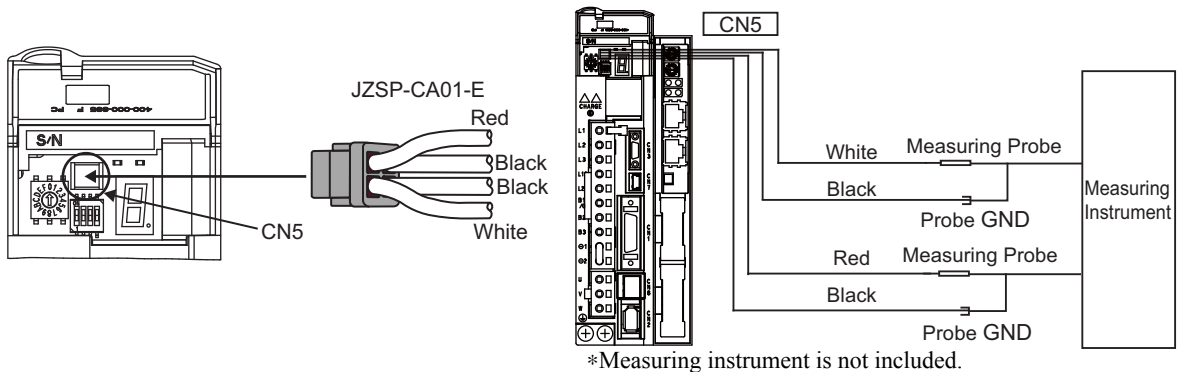

Line Color	Signal Name	Factory Setting
White	Analog monitor 1	Force reference: 1 V/100% rated force
Red	Analog monitor 2	Motor speed: 1 V/1000 mm/s
Black (2 lines)	GND	Analog monitor GND: 0 V

#### <Example>

Analog monitor output at n.□□00 (motor speed setting)

When multiplier is set to × 1:

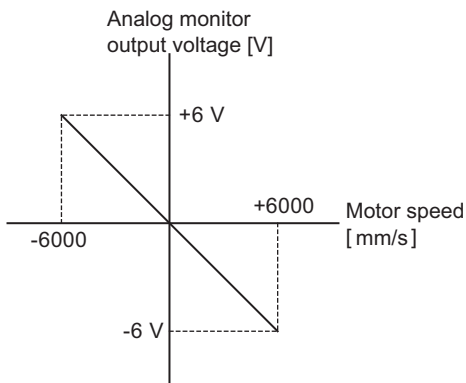

When multiplier is set to × 10:

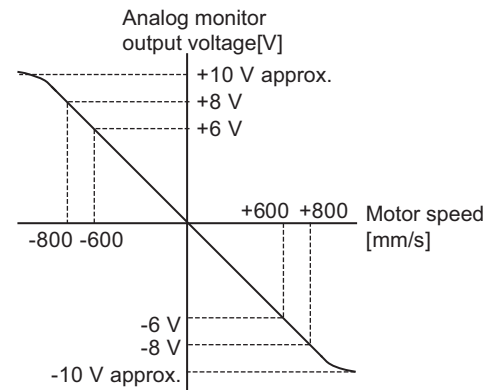

Note: Linear effective range: within ± 8V  
Resolution: 16-bit

### 5.1.4 Safety Precautions on Adjustment of Servo Gains



#### CAUTION

- If adjusting the servo gains, observe the following precautions.
  - Do not touch the movable section of the linear servomotor while the linear servomotor power is ON.
  - Before starting the linear servomotor, make sure that the emergency-stop circuit works correctly.
  - Make sure that a trial operation has been performed without any trouble.
  - Install a safety brake on the machine.

Yaskawa recommends that the following protective functions of the SERVOPACK are set to the correct settings before starting to adjust the servo gains.

#### (1) Overtravel Function

Set the overtravel function. For details on how to set the overtravel function, refer to *4.2.3 Overtravel*.

#### (2) Force Limit

Calculate the force required to operate the machine. Set the force limits so that the output force will not be greater than required. Setting the force limits can reduce the amount of shock applied to the machine in collisions and other cases.

If the force is set below the level of force required to operate the machine, overshooting or vibration may occur.

Refer to *4.4 Limiting Force* for details.

#### (3) Excessive Position Error Alarm Level

The excessive position error alarm is a protective function that will be enabled when the servo drive is used in position control mode.

For the optimum setting, the servomotor will be stopped after the error occurs if the servomotor performs unpredictably after receiving a reference.

The position error is the difference between the position reference and the actual position.

The position error can be calculated with the following equation.

$$\text{Position Error} = \frac{\text{Max. feed speed [reference unit/s]}}{\text{Pn102}}$$

- Excessive Position Error Alarm Level (Pn520 [reference unit])

$$\text{Pn520} > \frac{\text{Max. feed speed [reference unit/s]}}{\text{Pn102}} \times \underline{\underline{(1.2 \text{ to } 2)}}$$

Set the level to a value that satisfies these equations, and no excessive position error alarm will be generated during normal operation. The linear servomotor will be stopped, however, if the servomotor runs unpredictably after a reference is input. At the end of the equation, a coefficient is shown as “× (1.2 to 2).” This coefficient is used to add a margin that prevents a faulty alarm from occurring in actual operation of the linear servomotor.

If the acceleration/deceleration of the position reference exceeds the capacity of the linear servomotor, the linear servomotor cannot move at the requested speed, and the position error will be increased as not to satisfy these equations. If so, lower the level of the acceleration/deceleration for the position reference so that the linear servomotor can move at the requested speed or raise the allowable level of the position errors.

### ■ Related Parameter

Pn520	Excessive Position Error Alarm Level <span style="float: right;">Position</span>				Classification
	Setting Range	Setting Unit	Factory Setting	When Enabled	
	1 to 1073741823 ( $2^{30}-1$ )	1 reference unit	5242880	Immediately	Setup

### ■ Related Alarm

Alarm Display	Alarm Name	Alarm Contents
A.d00	Position Error Pulse Overflow	This alarm occurs when the number of position error pulses exceeds the value set for parameter Pn520 (Excessive Position Error Alarm Level).

#### (4) Vibration Detection Function

Set the vibration detection function to an appropriate value. For details on how to set the vibration detection function, refer to *6.16 Vibration Detection Level Initialization (Fn01B)*.

#### (5) Excessive Position Error Alarm Level at Servo ON

If the linear servomotor is turned ON when position error pulses remain, the linear servomotor will return to the home position and reset the number of pulses to zero. To prevent the linear servomotor from moving suddenly, set the appropriate level for the Excessive Position Error alarm when the linear servomotor is ON to restrict operation of the linear servomotor.

### ■ Related Parameters

Pn526	Excessive Position Error Alarm Level at Servo ON <span style="float: right;">Position</span>				Classification
	Setting Range	Setting Unit	Factory Setting	When Enabled	
	1 to 1073741823 ( $2^{30}-1$ )	1 reference unit	5242880	Immediately	Setup

Pn528	Excessive Position Error Warning Level at Servo ON <span style="float: right;">Position</span>				Classification
	Setting Range	Setting Unit	Factory Setting	When Enabled	
	10 to 100	1%	100	Immediately	Setup

Pn584	Speed Limit Level at Servo ON <span style="float: right;">Position</span>				Classification
	Setting Range	Setting Unit	Factory Setting	When Enabled	
	0 to 10000	1 mm/s	10000	Immediately	Setup

### ■ Related Alarms

Alarm Display	Alarm Name	Alarm Contents
A.d01	Position Error Pulse Overflow Alarm at Servo ON	Occurs if the servo ON command is received when the number of position error pulses is greater than the set value of Pn526.
A.d02	Position Error Pulse Overflow Alarm by Speed Limit at Servo ON	After a position error pulse has been input, Pn584 limits the speed if the servo ON command is received. If Pn584 limits the speed in such a state, this alarm occurs when the position references are input and the number of position error pulses exceeds the value set for parameter Pn520 (Excessive Position Error Alarm Level).

When an alarm occurs, refer to *8 Troubleshooting* and take the corrective actions.

## 5.2 Tuning-less Function

The tuning-less function is enabled in the factory setting. Do not disable this function for normal applications. If resonance is generated or excessive vibration occurs during position control, refer to 5.2.2 *Tuning-less Levels Setting (Fn200) Procedure* and reduce the set value of Pn170.2 for the tuning-less adjustment level and the set value in Pn170.3 for the tuning-less load level.

### CAUTION

- The tuning-less function is enabled in the factory setting. A sound may be heard for a moment when the linear servomotor power is turned ON for the first time after the servo drive is mounted to the machine. This sound does not indicate any problems; it means that the automatic notch filter was set. The sound will not be heard from the next time the linear servomotor power is turned ON. For details on the automatic notch filter, refer to (3) *Automatically Setting the Notch Filter* on the next page.
- The linear servomotor may vibrate if the mass ratio exceeds 30. If vibration occurs, set the mode to 2 in Fn200 or lower the adjustment level.

### 5.2.1 Tuning-less Function

The tuning-less function obtains a stable response without adjustment regardless of the type of machine or changes in the load.

#### (1) Enabling/Disabling Tuning-less Function

The following parameter is used to enable or disable the tuning-less function.

Parameter	Meaning	When Enabled	Classification
Pn170	n.□□□0	Disables tuning-less function.	After restart Setup
	n.□□□1	Enables tuning-less function. [Factory setting]	
	n.□□0□	Used as speed control. [Factory setting]	
	n.□□1□	Used as speed control and host controller used as position control.	

#### (2) Application Restrictions

The tuning-less function can be used in position control or speed control. This function is not available in force control.

However, set Pn170.1 = 1 when implementing a position loop in the host controller while the SERVOPACK is used as a speed control.

The following application restrictions apply to the tuning-less function.

Control Function	Availability	Remarks
Vibration detection level initialization (Fn01B)	Available	
Advanced autotuning (Fn201)	Available (Some conditions apply)	<ul style="list-style-type: none"> <li>• This function can be used when the mass is calculated.</li> <li>• While this function is being used, the tuning-less function cannot be used temporarily.</li> </ul>
Advanced autotuning by reference (Fn202)	Not available	
One-parameter tuning (Fn203)	Not available	
Anti-resonance control adjustment function (Fn204)	Not available	
Vibration suppression function (Fn205)	Not available	
EasyFFT (Fn206)	Available	While this function is being used, the tuning-less function cannot be used temporarily.
Friction compensation	Not available	
Gain switching	Not available	
Offline Mass Setting *	Not available	

Control Function	Availability	Remarks
Mechanical analysis *	Available	While this function is being used, the tuning-less function cannot be used temporarily.

\* Operate using SigmaWin+.

### (3) Automatically Setting the Notch Filter

Usually, set this function to Auto Setting. (The notch filter is factory-set to Auto Setting.)

If this function is set to Auto Setting, vibration will be detected automatically and the notch filter will be set.

Set this function to Not Auto Setting only if you do not change the notch filter setting before executing tuning-less function.

Parameter	Meaning	When Enabled	Classification
<b>Pn460</b>	n.□0□□	Immediately	Tuning
	n.□1□□		

### (4) Tuning-less Level Settings

Two tuning-less levels are available: the tuning-less adjustment level and tuning-less load level. Both level can be set in the Fn200 utility function and in the Pn170 parameter.

#### ■ Tuning-less Adjustment Level

The servo gain can be adjusted between rigidity level 4 (high gain) and rigidity level 0 (low gain) by changing the tuning-less adjustment level with the utility function and parameter settings.

##### a) By using the utility function

To change the setting, refer to 5.2.2 *Tuning-less Levels Setting (Fn200) Procedure*.

Tuning Level	Meaning
Level 0	Rigidity level 0
Level 1	Rigidity level 1
Level 2	Rigidity level 2
Level 3	Rigidity level 3
Level 4	Rigidity level 4 [Factory setting]

##### b) By using the parameter

Parameter	Meaning	When Enabled	Classification
<b>Pn170</b>	n.□0□□	Immediately	Setup
	n.□1□□		
	n.□2□□		
	n.□3□□		
	n.□4□□		

### ■ Tuning-less Load Level

The servo gain can be adjusted by using the utility function and parameter settings to change the load level in accordance with the size of the load.

#### a) By using the utility function

To change the setting, refer to *5.2.2 Tuning-less Levels Setting (Fn200) Procedure*.

Load Level	Meaning
Mode 0	Load level: Low
Mode 1	Load level: Medium [Factory setting]
Mode 2	Low level: High

#### b) By using by the parameter

Parameter	Meaning	When Enabled	Classification	
<b>Pn170</b>	n.0□□□	Load level: Low (Mode 0)	Immediately	Setup
	n.1□□□	Load level: Medium (Mode 1) [Factory setting]		
	n.2□□□	Low level: High (Mode 2)		

## 5.2.2 Tuning-less Levels Setting (Fn200) Procedure

### CAUTION

To ensure safety, perform tuning-less function in a state where the SERVOPACK can come to an emergency stop at anytime.

The following procedure is used for setting the tuning-less levels.

Setting tuning-less Levels is performed from the digital operator (optional), or SigmaWin+.

The operating procedure from the Digital Operator is described here.



















For the basic operation of the digital operator, refer to *Σ-V series User's Manual, Operation of Digital Operator* (SIEP S800000 55).





### (1) Before Performing Tuning-less Function

Check the following settings before performing the tuning-less function, or otherwise “NO-OP” will be displayed during the tuning-less operation.

- The tuning-less function must be enabled. (Pn170.0 = 1)
- The write prohibited setting (Fn010) must not be set.

### (2) Operating Procedure with Digital Operator

Step	Display after Operation	Keys	Operation
1	<pre> RUN      —FUNCTION— Fn080: Pole Detect Fn200: TuneLvl Set Fn201: AAT Fn202: Ref-AAT           </pre>	  	Press the  Key to view the main menu for the utility function mode. Use the  or  Key to move through the list, select Fn200.
2	<pre> RUN      —TuneLvlSet— Mode=1           </pre>		Press the  Key to display the tuning-less mode setting screen. Notes: <ul style="list-style-type: none"> <li>• If the display does not switch and “NO-OP” is displayed, the write prohibited setting is set in Fn010. Change the setting in Fn010 and press the key again after enabling writing.</li> <li>• If the response waveform causes overshooting or if the mass ratio exceeds 30 (i.e., outside the scope of product guarantee), press the  Key and change the mode setting to 2.</li> <li>• If a high-frequency noise is heard, press the  Key and change to the mode setting to 0.</li> <li>• The tuning mode can be also changed in Pn170.3.</li> </ul>
3	<pre> RUN      —TuneLvlSet— Level=4           </pre>		Press the  Key to display the tuning level setting screen.
4	<pre> RUN      —TuneLvlSet— Level=4 NF2           </pre> <p style="text-align: center;">↑ 2nd notch filter</p>	  	Press the  or  Key to select the tuning level. Select the tuning level from 0 to 4. The larger the value, the higher the gain is and the better response performance will be. (The factory setting is 4.) Notes: <ul style="list-style-type: none"> <li>• Vibration may occur if the tuning level is too high. Lower the tuning level if vibration occurs.</li> <li>• If a high-frequency noise is heard, press the  Key to automatically set a notch filter for the vibration frequency.</li> <li>• The tuning level can be also changed in Pn170.2.</li> </ul>

Step	Display after Operation	Keys	Operation
5	<pre> RUN  --TuneLvISet-- Level = 4 </pre>		Press the  Key. "DONE" will blink on the status display for approx. 2 s and then "RUN" will be displayed. The settings will be saved in the SERVO-PACK.
6	<pre> RUN  --FUNCTION-- Fn030 Fn200 Fn201 Fn202 </pre>		Press the  Key to complete the tuning-less operation. The screen in step 1 will appear again.

Note: If the gain level is changed, the automatically set notch filter will be canceled. If vibration occurs, however, the notch filter will be set again.

### (3) Alarm and Corrective Actions

The autotuning alarm (A.521) will occur if resonance is generated or excessive vibration occurs during position control.

#### ■ Resonance Sound

Take one of the following actions to correct the problem.

- Reduce the setting of the tuning adjustment level or load level.
- Reduce the setting of Pn170.3 or Pn170.2.

#### ■ Excessive Vibration during Position Control

Take one of the following actions to correct the problem.

- Increase the setting of the tuning load level or reduce the setting of the tuning adjustment level.
- Increase the setting of Pn170.3 or reduce the setting of Pn170.2.



#### (4) Parameters Disabled by Tuning-less Function

When the tuning-less function is enabled in the factory settings, the setting of these parameters are not available: Pn100, Pn101, Pn102, Pn103, Pn104, Pn105, Pn106, Pn160, Pn139, and Pn408. These gain-related parameters, however, may become effective depending on the executing conditions of the functions specified in the following table. If EasyFFT is executed when the tuning-less function is enabled, the settings in Pn100, Pn104, Pn101, Pn105, Pn102, Pn106, and Pn103, as well as the manual gain switch setting, will be enabled, but the settings in Pn408.3, Pn160.0, and Pn139.0 will be not enabled.

Parameters Disabled by Tuning-less Function			Related Functions and Parameters		
Item	Name	Pn Number	Force Control	Easy FFT	Mechanical Analysis (Vertical Axis Mode)
Gain	Speed Loop Gain 2nd Speed Loop Gain	Pn100 Pn104	○	○	○
	Speed Loop Integral Time Constant 2nd Speed Loop Integral Time Constant	Pn101 Pn105	×	○	○
	Position Loop Gain 2nd Position Loop Gain	Pn102 Pn106	×	○	○
	Mass Ratio	Pn103	○	○	○
	Advanced Control	Friction Compensation Function Selection	Pn408.3	×	×
Anti-resonance Control Related Switch		Pn160.0	×	×	×
Gain Switching	Gain Switching Selection Switch	Pn139.0	×	×	×

Note: ○: Available  
×: Not available

## 5.3 Advanced Autotuning (Fn201)

This section describes the adjustments with advanced autotuning.



**IMPORTANT**

- Advanced autotuning starts adjustments based on the set speed loop gain (Pn100). Therefore, precise adjustments cannot be made if there is vibration when starting adjustments. In this case, make adjustments after setting a fully stable gain using one-parameter tuning (Fn203).
- Before performing advanced autotuning with the tuning-less function enabled (Pn170.0 = 1: Factory setting), always set Jcalc to ON to calculate the mass. The tuning-less function will automatically be disabled, and the gain will be set by advanced autotuning.  
With Jcalc set to OFF so the mass is not calculated, "Error" will be displayed on the panel operator, and advanced autotuning will not be performed.
- If the operation conditions, such as the machine load or drive system, are changed by resetting Jcalc to ON to calculate the mass after advanced autotuning, then change the related parameters to disable any values that were adjusted before performing advanced autotuning once again. If advanced autotuning is performed without changing the parameters, machine vibration may occur, resulting in damage to the machine.  
Pn00B.0 = 1 (Displays all parameters.)  
Pn140.0 = 0 (Does not use model following control.)  
Pn160.0 = 0 (Does not use anti-resonance control.)  
Pn408 = n.00□□ (Does not use friction compensation, 1st notch filter, or 2nd notch filter.)

### 5.3.1 Advanced Autotuning

Advanced autotuning automatically operates the SERVOPACK (in reciprocating movement in the forward and reverse directions) within set limits and makes adjustment automatically according to the mechanical characteristics while the SERVOPACK is operating.

Advanced autotuning can be performed without connecting the host controller. The following automatic operation specifications apply.

- Max. motor speed: Rated motor speed  $\times 2/3$
- Acceleration force\*: Approximately 100% of rated motor force
- Travel distance: Set in unit of 1000 reference units. Factory setting is 90 mm.

\* The acceleration force varies with the influence of the mass ratio (Pn103), machine friction, and external disturbance.

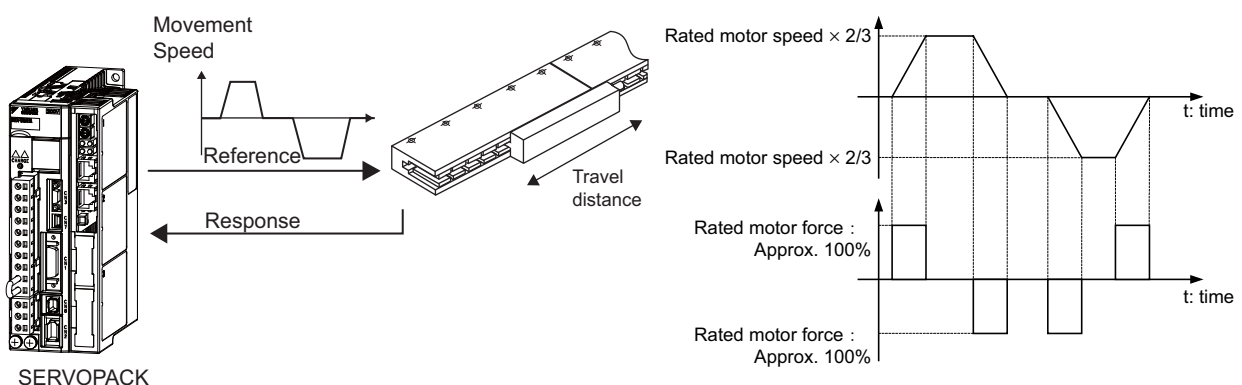

Advanced autotuning performs the following adjustments.

- Mass ratio
- Gains (e.g., position loop gain and speed loop gain)
- Filters (force reference filter and notch filter)
- Friction compensation
- Anti-resonance control
- Vibration suppression (Mode = 2 or 3)

Refer to 5.3.3 *Related Parameters* for parameters used for adjustments.

### CAUTION

- Because advanced autotuning adjusts the SERVOPACK during automatic operation, vibration or overshooting may occur. To ensure safety, perform advanced autotuning in a state where the SERVOPACK can come to an emergency stop at any time.

## (1) Before Performing Advanced Autotuning

Check the following settings before performing advanced autotuning.

The message “NO-OP” indicating that the settings are not appropriate will be displayed, if all of the following conditions are not met.

- The main circuit power supply must be ON.
- There must be no overtravel.
- The servomotor power must be OFF.
- The control method must not be set to force control.
- The gain selection switch must be in manual switching mode (Pn139.0 = 0).
- Gain setting 1 must be selected.
- The test without a motor function must be disabled (Pn00C.0 = 0).
- All alarms and warning must be cleared.
- The hardwire baseblock (HWBB) must be disabled.
- The write prohibited setting (Fn010) must not be set to write-protect parameters.
- Jcalc must be set to ON to calculate the mass when the tuning-less function is enabled (Pn170.0 = 1: factory setting) or the tuning-less function must be disabled (Pn170.0 = 0).

Note:

- If advanced autotuning is started while the SERVOPACK is in speed control, the mode will change to position control automatically to perform advanced autotuning. The mode will return to speed control after completing the adjustment. To perform advanced autotuning in speed control, set the mode to 1 (Mode = 1).

## (2) When Advanced Autotuning Cannot be Performed

Advanced autotuning cannot be performed normally under the following conditions. If any of the following conditions exists, perform advanced autotuning by reference or one-parameter tuning.

Refer to 5.4 *Advanced Autotuning by Reference (Fn202)* and 5.5 *One-parameter Tuning (Fn203)* for details.

- The machine system can work only in a single direction.
- The operating range is within 5 mm.

## (3) When Advanced Autotuning Cannot be Adjusted

Advanced autotuning may not be performed normally under the following conditions. If the result of autotuning is not satisfactory, perform advanced autotuning by reference (Fn202) or one-parameter tuning (Fn203.)

Refer to 5.4 *Advanced Autotuning by Reference (Fn202)* and 5.5 *One-parameter Tuning (Fn203)* for details.

- The operating range is not applicable.
- The mass changes within the set operating range.
- The machine has high friction.
- The rigidity of the load is low and vibration occurs when positioning is performed.
- The position integration function is used.
- P control operation (proportional control) is performed.

Note: If a setting is made for calculating the mass, an error will result when P control operation is selected using /P-CON signal while the mass is being calculated.

- The mode switch is used.

Note: If a setting is made for calculating the mass, the mode switch function will be disabled while the mass is being calculated. At that time, PI control will be used. The mode switch function will be enabled after calculating the mass.

- Speed feedforward or force feedforward is input.
- The positioning completed width (Pn522) is too small.

 <b>IMPORTANT</b>	<ul style="list-style-type: none"> <li>• Advanced autotuning makes adjustments based on the positioning completed width (Pn522). If the SERVOPACK is operated in position control, set the electronic gear ratio (Pn20E/Pn210) and positioning completed width (Pn522) to the actual value during operation. If the SERVOPACK is operated in speed control, use the factory settings.</li> <li>• Unless the positioning completed signal (/COIN) is turned ON within approximately 3 seconds after positioning has been completed, "WAITING" will blink. Furthermore, unless the positioning completed signal (/COIN) is turned ON within approximately 10 seconds, "Error" will blink for 2 seconds and tuning will be aborted.</li> </ul>
---	---

Change only the overshoot detection level (Pn561) to finely adjust the without changing the positioning completed width (Pn522). Because Pn561 is set by default to 100%, the allowable amount of overshooting is the same amount as that for the positioning completed width.

When Pn561 is set to 0%, the amount of overshooting can be adjusted to prevent any overshooting in the positioning completed width. If the setting of Pn561 is changed, however, the positioning time may be extended.

Pn561	Overshoot Detection Level				Classification	
			Speed	Position		Force
	Setting Range	Setting Unit	Factory Setting	When Enabled		
	0 to 100	1%	100	Immediately	Setup	

## 5.3.2 Advanced Autotuning Procedure

The following procedure is used for advanced autotuning.

Advanced autotuning is performed from the Digital Operator (option) or SigmaWin+.















The operating procedure from the Digital Operator is described here.





















For the basic operations of the Digital Operator, refer to the *Σ-V series User's Manual, Operation of Digital Operator* (SIEP S800000 55).

### CAUTION

- When using the SERVOPACK with Jcalc = OFF (mass is not calculated), be sure to set a suitable value for the mass ratio (Pn103). If the setting greatly differs from the actual mass ratio, normal control of the SERVOPACK may not be possible, and vibration may result.

#### (1) Operating Procedure

Step	Display after Operation	Keys	Operation
1	<pre>BB      —FUNCTION— Fn200: TuneLvl Set Fn201: AAT Fn202: Ref-AAT Fn203: OnePrmTun</pre>	  	Press the  Key to view the main menu for the utility function mode. Use the  or  Key to move through the list, select Fn201.
2	<pre>BB      Status Display BB      Advanced AT Jcalc=ON Mode=2 Type=2 Stroke=+00800000 (0003. 0) rev</pre>		Press the  Key to display the initial setting screen for advanced autotuning.
3	<pre>BB      Advanced AT Jcalc=ON Mode=2 Type=2 Stroke=+00800000 (0003. 0) rev</pre>	  	Press the  ,  or  Key and set the items in steps 3-1 to 3-4.
3-1	<p>■Calculating Mass            Select the mode to be used.            Usually, set Jcalc to ON.            Jcalc = ON: Calculates the mass. [Factory setting]            Jcalc = OFF: Does not calculate the mass.            Note:            If the mass is already known from the machine specifications, set the value in Pn103 and set Jcalc to OFF.</p>		
3-2	<p>■Mode Selection            Select the mode.            Mode = 1: Makes adjustments considering responsiveness and stability. (Standard level)            Mode = 2: Makes adjustments for positioning. [Factory setting]            Mode = 3: Makes adjustments for positioning, giving priority to overshooting suppression.</p>		
3-3	<p>■Type Selection            Select the type according to the machine element to be driven. If there is noise or the gain does not increase, better results may be obtained by changing rigid type.            Type = 1: For belt drive mechanisms.            Type = 2: For ball screw drive mechanisms [Factory setting].            Type = 3: For rigid systems, such as a gear.</p>		
3-4	<p>■STROKE (Travel Distance) Setting            Travel distance setting range:            The travel distance setting range is from -99990000 to +99990000. Specify the STROKE (travel distance) in increments of 1000 reference units. The negative (-) direction is for reverse movement, and the positive (+) direction is for forward movement.            Initial value: 90 mm            Notes:  <ul style="list-style-type: none"> <li>Set the travel distance of the linear servomotor to at least 5 mm; otherwise, “Error” will be displayed and the advanced autotuning cannot be performed.</li> <li>To calculate the mass ratio and ensure precise tuning, it is recommended to set the travel distance to 90 mm.</li> </ul> </p>		

Step	Display after Operation	Keys	Operation
4	<pre>BB      Advanced AT Pn103=00100 Pn100=0040.0 Pn101=0020.00 Pn102=0040.0</pre>		Press the  Key. The advanced autotuning execution screen will be displayed.
5	<pre>RUN      Advanced AT Pn103=00100 Pn100=0040.0 Pn101=0020.00 Pn141=0050.0</pre>		Press the  Key. The linear servomotor will become servo ON state and the display will change from “BB” to “RUN.” Note: If the mode is set to 2 or 3, the “Pn102” display will change to the “Pn141.”
6	<pre>ADJ      Advanced AT Pn103=00300 Pn100=0040.0 Pn101=0020.00 Pn141=0050.0</pre> <p>Display example: After the mass ratio is calculated.</p>	 	Calculates the mass ratio. Press the  Key if a positive (+) value is set in STROKE (travel distance), or press the  Key if a negative (-) value is set. Calculation of the mass ratio will start. While the mass ratio is being calculated, the set value for Pn103 will blink, and the “RUN” display will change to blinking “ADJ.” When the calculation has been completed, the set value will stop blinking and the calculated mass ratio will be displayed. The linear servomotor will remain in servo ON state, but the auto run operation will enter HOLD status. Notes: <ul style="list-style-type: none"> <li>• The wrong key for the set travel direction is pressed, the calculation will not start.</li> <li>• If the mass ratio is not calculated, the set value for Pn103 will be displayed but not blink.</li> <li>• If “NO-OP” or “Error” are displayed, press the  Key to cancel the function. Refer to (2) <i>Failure in Operation</i> and take a corrective action to enable operation.</li> </ul>
7		 	After the linear servomotor is temporarily stopped, press the  Key to save the calculated value of the mass ratio in the SERVOPACK. Then, “DONE” will blink for approx. 1 second, and “ADJ” will be displayed. To calculate the mass ratio but not save, press the  Key.
8	<pre>ADJ      Advanced AT Pn103=00300 Pn100=0100.0 Pn101=0006.36 Pn141=0150.0</pre>	 	<p>■Gain Adjustment</p> <p>When the  or  Key is pressed according to the sign (+ or -) of the value set for STROKE (travel distance), the calculated value of the mass ratio will be written to the SERVOPACK and the auto run operation will restart. While the linear servomotor is running, the gains and filters will be automatically set. “ADJ” will blink during the auto setting operation. Note: Precise adjustments cannot be made and “Error” will be displayed as the status if there is vibration when starting adjustments. If that occurs, make adjustments using one-parameter tuning (Fn203).</p>
9	<pre>ADJ      Advanced AT Pn103=00300 Pn100=0100.0 Pn101=0006.36 Pn141=0150.0</pre>		When the adjustment has been completed normally, the linear servomotor becomes the servo OFF state, and “END” will blink for approx. 2 seconds and “ADJ” will be displayed on the status display.
10	<pre>BB      Advanced AT Pn103=00300 Pn100=0100.0 Pn101=0006.36 Pn141=0150.0</pre>		Press the  Key. The adjusted values will be written to the SERVOPACK, “DONE” will blink for approx. 2 seconds, and “BB” will be displayed. Note: No to save the values, press the  Key. The display will return to the display in step 1.
11	To enable the change in the setting, turn OFF the power and ON again.		

## (2) Failure in Operation

This section describes the causes and corrective actions in case the operation has not been successfully completed.

### ■ If “NO-OP” is shown

Probable Cause	Corrective Actions
The main circuit power supply was OFF.	Turn ON the main circuit power supply.
An alarm or warning occurred.	Remove the cause of the alarm or the warning.
Overtraveling occurred.	Remove the cause of the overtravel.
Gain setting 2 was selected by gain switching.	Turn OFF the automatic gain switching.
The HWBB function operated.	Cancel the HWBB function.

### ■ If “Errors” is shown

Error	Probable Cause	Corrective Actions
The gain adjustment was not successfully completed.	<ul style="list-style-type: none"> <li>Machine vibration is occurring or the positioning completed signal (/COIN) is repeatedly turning ON and OFF.</li> </ul>	<ul style="list-style-type: none"> <li>Increase the set value for Pn522.</li> <li>Change the mode from 2 to 3.</li> <li>If machine vibration occurs, suppress the vibration with the anti-resonance control adjustment function and the vibration suppression function.</li> </ul>
An error occurred during the calculation of the mass ratio.	Refer to the following table ■ <i>Errors during Calculation of Mass Ratio</i> .	
Travel distance setting error	The travel distance is set to approximately 5 mm or less, which is less than the minimum adjustable travel distance.	Increase the travel distance. It is recommended to set the travel distance to around 90 mm.
The positioning completed signal (/COIN) did not turn ON within approximately 10 seconds after positioning adjustment was completed.	The positioning completed width is too narrow or the proportional control (P control) is being used.	<ul style="list-style-type: none"> <li>Increase the set value for Pn522.</li> <li>If P control is used, turn OFF the /P-CON signal.</li> </ul>
A setting error occurred in the mass ratio calculation when the tuning-less function was activated.	When the tuning-less function was activated, Jcalc was set to OFF, so the mass ratio was not calculated.	<ul style="list-style-type: none"> <li>Turn OFF the tuning-less function.</li> <li>Set Jcalc to ON, so the mass ratio will be calculated.</li> </ul>

### ■ Errors during Calculation of Mass Ratio

The following table shows the probable causes of errors that may occur during the calculation of the mass ratio with the Jcalc set to ON, along with corrective actions for the errors.

Error Display	Cause	Corrective Action
Err1	The SERVOPACK started calculating the mass ratio, but the calculation was not completed.	<ul style="list-style-type: none"> <li>Increase the speed loop gain (Pn100).</li> <li>Increase the STROKE (travel distance).</li> </ul>
Err2	The mass ratio fluctuated greatly and did not converge within 10 tries.	Set the calculation value based on the machine specifications in Pn103 and execute the calculation with the Jcalc set to OFF.
Err3	Low-frequency vibration was detected.	Double the mass calculating start level (Pn324).
Err4	The force limit was reached.	<ul style="list-style-type: none"> <li>Increase the force limit value.</li> <li>Double the mass calculating start level (Pn324).</li> </ul>
Err5	While calculating the mass ratio, the speed control was set to proportional control with P-CON input.	Operate the SERVOPACK with PI control while calculating the mass ratio.

### (3) Related Functions

This section describes the functions related to the advanced autotuning function.

#### ■ Notch Filter

Usually, set this function to Auto Setting. (The notch filter is factory-set to Auto Setting.)

If this function is set to Auto Setting, vibration will be detected automatically and the notch filter will be set.

Set this function to Not Auto Setting only if you do not change the notch filter setting before executing advanced autotuning.

Parameter		Function	When Enabled	Classification
<b>Pn460</b>	n.□□□0	Does not set the 1st notch filter automatically using the utility function.	Immediately	Tuning
	n.□□□1	Sets the 1st notch filter automatically using the utility function. [Factory setting]		
	n.□0□□	Does not set the 2nd notch filter automatically using the utility function.		
	n.□1□□	Sets the 2nd notch filter automatically using the utility function. [Factory setting]		

#### ■ Anti-Resonance Control Adjustment Function

This function reduces low vibration frequency; which the notch filter does not detect.

Usually, set this function to Auto Setting. (The anti-resonance control is factory-set to Auto Setting.)

When this function is set to Auto Setting, vibration will be automatically detected during advanced autotuning and anti-resonance control will be automatically adjusted and set.

Parameter		Function	When Enabled	Classification
<b>Pn160</b>	n.□□0□	Does not use the anti-resonance control automatically using the utility function.	Immediately	Tuning
	n.□□1□	Uses the anti-resonance control automatically using the utility function. [Factory setting]		

#### ■ Vibration Suppression

The vibration suppression function suppresses transitional vibration at frequency as low as 1 to 100 Hz that is generated mainly when positioning if the machine stand vibrates.

Usually, set this function to Auto Setting. (The vibration suppression function is factory-set to Auto Setting.)

When this function is set to Auto Setting, vibration will be automatically detected during advanced autotuning and model following control with vibration suppression will be automatically adjusted and set.

Set this function to Not Auto Setting only if you do not change the setting for model following control with vibration suppression before executing advanced autotuning.

Note: This function uses model following control. Therefore, the function can be executed only if the mode is set to 2 or 3.

#### Related Parameters

Parameter		Function	When Enabled	Classification
<b>Pn140</b>	n.□0□□	Does not use the vibration suppression function automatically using the utility function.	Immediately	Tuning
	n.□1□□	Uses the vibration suppression function automatically using the utility function. [Factory setting]		



## ■ Friction Compensation

This function compensates for changes in the following conditions.

- Changes in the viscous resistance of the lubricant, such as the grease, on the sliding parts of the machine
- Changes in the load resistance resulting from fluctuations in the machine assembly
- Secular changes in the load resistance

Conditions to which friction compensation is applicable depend on the mode. The friction compensation setting in Pn408.3 applies when the mode is 1.

Friction Compensation Selection		Mode		
		Mode = 1	Mode = 2	Mode = 3
Pn408	n.0□□□ [Factory setting]	Adjusted without the friction compensation function.	Adjusted with the friction compensation function.	Adjusted with the friction compensation function.
	n.1□□□	Adjusted with the friction compensation function.		

## ■ Feedforward

 <b>IMPORTANT</b>	<ul style="list-style-type: none"> <li>• Model following control is used to make optimum feedforward settings in the servo. Therefore, model following control from the host controller is not used together with either the speed feedforward input or force feedforward input. An improper speed feedforward input or force feedforward input may result in overshooting.</li> </ul>
--	--

If Pn140 is set to the factory setting and the mode setting is changed to 2 or 3, the feedforward gain (Pn109) (refer to 5.9.1) will become unavailable.

The following settings are required if model following control is used from the host controller (through the Command Option Module) together with the speed feedforward input or force feedforward input.

Parameter		Function	When Enabled	Classification
Pn140	n.0□□□	Does not use the model following control together with speed/force feedforward input. [Factory setting]	Immediately	Tuning
	n.1□□□	Uses the model following control together with speed/force feedforward input.		

### 5.3.3 Related Parameters

The following parameters are set automatically by using advanced autotuning function.

Parameter	Name
<b>Pn100</b>	Speed Loop Gain
<b>Pn101</b>	Speed Loop Integral Time Constant
<b>Pn102</b>	Position Loop Gain
<b>Pn121</b>	Friction Compensation Gain
<b>Pn123</b>	Friction Compensation Coefficient
<b>Pn124</b>	Friction Compensation Frequency Correction
<b>Pn125</b>	Friction Compensation Gain Correction
<b>Pn141</b>	Model Following Control Gain
<b>Pn143</b>	Model Following Control Bias (Forward Direction)
<b>Pn144</b>	Model Following Control Bias (Reverse Direction)
<b>Pn145</b>	Vibration Suppression 1 Frequency A
<b>Pn146</b>	Vibration Suppression 1 Frequency B
<b>Pn147</b>	Model Following Control Speed Feedforward Compensation
<b>Pn161</b>	Anti-Resonance Frequency
<b>Pn163</b>	Anti-Resonance Damping Gain
<b>Pn401</b>	Force Reference Filter Time Constant
<b>Pn408</b>	Notch Filter Selection/Friction Compensation Selection
<b>Pn409</b>	1st Notch Filter Frequency
<b>Pn40A</b>	1st Notch Filter Q Value
<b>Pn40C</b>	2nd Notch Filter Frequency
<b>Pn40D</b>	2nd Notch Filter Q Value

## 5.4 Advanced Autotuning by Reference (Fn202)

This section describes the adjustments with advanced autotuning by reference.



**IMPORTANT**

- Advanced autotuning by reference starts adjustments based on the set speed loop gain (Pn100). Therefore, precise adjustments cannot be made if there is vibration when starting adjustments. In this case, make adjustments after setting a fully stable gain using one-parameter tuning (Fn203).

### 5.4.1 Advanced Autotuning by Reference

Advanced autotuning by reference is used to automatically achieve optimum tuning of the SERVOPACK in response to the user reference inputs from the host controller.

Advanced autotuning by reference is performed generally to fine-tune the SERVOPACK after advanced autotuning of the SERVOPACK has been performed.

If the mass ratio is set correctly in Pn103, advanced autotuning by reference can be performed without performing advanced autotuning.

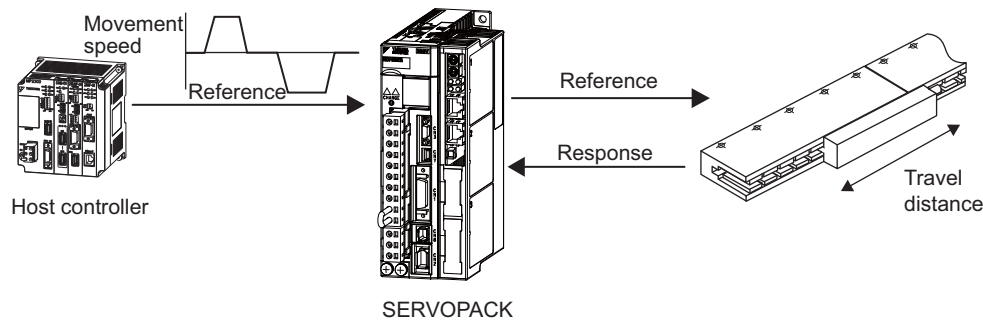

Advanced autotuning by reference performs the following adjustments.

- Gains (e.g., position loop gain and speed loop gain)
- Filters (force reference filter and notch filter)
- Friction compensation
- Anti-resonance control
- Vibration suppression

Refer to *5.4.3 Related Parameters* for parameters used for adjustments.

For information on how to input operation references, refer to the manual of the connected command option module.



**CAUTION**

- Because advanced autotuning by reference adjusts the SERVOPACK during automatic operation, vibration or overshooting may occur. To ensure safety, perform advanced autotuning by reference in a state where the SERVOPACK can come to an emergency stop at any time.
- Be sure to set a suitable value for the mass ratio (Pn103) using advanced autotuning before advanced autotuning by reference is performed. If the setting greatly differs from the actual mass ratio, normal control of the SERVOPACK may not be possible, and vibration may result.

## (1) Before Performing Advanced Autotuning by Reference

Check the following settings before performing advanced autotuning by reference. The message “NO-OP” indicating that the settings are not appropriate will be displayed, if all of the following conditions are not met.

- The SERVOPACK must be in Servo Ready status (Refer to 4.6.4).
- There must be no overtravel.
- The servomotor power must be OFF.
- The position control must be selected when the servomotor power is ON.
- The gain selection switch must be in manual switching mode (Pn139.0 = 0).
- Gain setting 1 must be selected.
- The test without a motor function must be disabled. (Pn00C.0 = 0).
- All warnings must be cleared.
- The write prohibited setting (Fn010) must not be set to write-protect parameters.
- The tuning-less function must be disabled (Pn170.0 = 0).

## (2) When Advanced Autotuning by Reference Cannot Be Adjusted

Advanced autotuning by reference may not be performed normally under the following conditions. If the result of autotuning is not satisfactory, perform one-parameter tuning. Refer to 5.5 *One-parameter Tuning (Fn203)* for details.

- The travel distance in response to references from the host controller is the same as or smaller than the set positioning completed width (Pn522).
- The motor speed in response to references from the host controller is the same as or smaller than the set zero speed level (Pn581).
- The stopping time, i.e., the period while the positioning completed /COIN signal is OFF, is 10 ms or shorter.
- The rigidity of the load is low and vibration occurs when positioning is performed.
- The position integration function is used.
- P control operation (proportional control) is performed.
- The mode switch is used.
- The positioning completed width (Pn522) is too small.

 <b>IMPORTANT</b>	<ul style="list-style-type: none"> <li>• Advanced autotuning by reference makes adjustments based on the positioning completed width (Pn522). Set the electronic gear ratio (Pn20E/Pn210) and positioning completed width (Pn522) to the actual value during operation.</li> <li>• Unless the positioning completed signal (/COIN) is turned ON within approximately 3 seconds after positioning has been completed, “WAITING” will blink. Furthermore, unless the positioning completed signal (/COIN) is turned ON within approximately 10 seconds, “Error” will blink for 2 seconds and tuning will be aborted.</li> </ul>
---	---

Change only the overshoot detection level (Pn561) to finely adjust the amount of overshooting without changing the positioning completed width (Pn522). Because Pn561 is set by default to 100%, the allowable amount of overshooting is the same amount as that for the positioning completed width.

When Pn561 is set to 0%, the amount of overshooting can be adjusted without any overshooting in the positioning completed width. If the setting of Pn561 is changed, however, the positioning time may be extended.

Pn561	Overshoot Detection Level				Classification	
			Speed	Position		Force
	Setting Range	Setting Unit	Factory Setting	When Enabled		
	0 to 100	1%	100	Immediately	Setup	

## 5.4.2 Advanced Autotuning by Reference Procedure





















The following procedure is used for advanced autotuning by reference.



Advanced autotuning by reference is performed from the Digital Operator (option) or SigmaWin+.

The operating procedure from the Digital Operator is described here.

For basic operations of the Digital Operator, refer to the *Σ-V series User's Manual, Operation of Digital Operator* (SIEP S800000 55).

### (1) Operating Procedure

Step	Display after Operation	Keys	Operation
1	<pre>BB      —FUNCTION— Fn201: AAT Fn202: Ref-AAT Fn203: OnePrmTun Fn204: A-Vib Sup</pre>	  	<p>Press the  Key to view the main menu for the utility function mode.</p> <p>Use the  or  Key to move through the list, select Fn202.</p>
2	<pre>— Status Display BB      Advanced AT Mode=3 Type=2</pre>		<p>Press the  Key to display the initial setting screen for advanced autotuning by reference.</p>
3	<pre>BB      Advanced AT Mode=3 Type=2</pre>	  	<p>Press the   or  Key and set the items in steps 3-1 and 3-2.</p>
3-1	<p>■Mode Selection Select the mode.</p> <p>Mode = 1: Makes adjustments considering responsiveness and stability. (Standard level) Mode = 2: Makes adjustments for positioning. [Factory setting] Mode = 3: Makes adjustments for positioning, giving priority to overshooting suppression.</p>		
3-2	<p>■Type Selection Select the type according to the machine element to be driven. If there is noise or the gain does not increase, better results may be obtained by changing the rigid type.</p> <p>Type = 1: For belt drive mechanisms. Type = 2: For ball screw drive mechanisms [Factory setting]. Type = 3: For rigid systems, such as a gear.</p>		
4	<pre>BB      Advanced AT Pn103=0000.0 Pn100=0040.0 Pn101=0020.00 Pn141=0050.0</pre>		<p>Press the  Key. The advanced autotuning execution screen will be displayed.</p> <p>Note: If the mode is set to 2 or 3, the “Pn102” display will change to the “Pn141”.</p>
5	<pre>RUN     Advanced AT Pn103=0030.0 Pn100=0040.0 Pn101=0020.00 Pn141=0050.0</pre>		<p>Input a servo ON command.</p>
6	<pre>ADJ     Advanced AT Pn103=0030.0 Pn100=0100.0 Pn101=0006.36 Pn141=0150.0</pre>	 	<p>Start to adjust using  or  Key. “ADJ” will blink on the status display.</p> <p>Note: Adjustment cannot be performed during “BB” is shown on the status display.</p>
7	<pre>ADJ     Advanced AT Pn103=0030.0 Pn100=0100.0 Pn101=0006.36 Pn141=0150.0</pre>		<p>When the adjustment has been completed normally, “END” will blink for approx. 2 seconds and “ADJ” will be displayed on the status display.</p>

Step	Display after Operation	Keys	Operation
8	<pre> RUN      Advanced AT Pn103=00300 Pn100=0100.0 Pn101=0006.36 Pn141=0150.0 </pre>		<p>Press the  Key. The adjusted values will be written to the SERVOPACK, “DONE” will blink for approx. 2 seconds, and then “RUN” will be displayed.</p> <p>Note: Not to save the values set in step 6, press the  Key. The display will return to the display in step 1.</p>
9	To enable the change in the setting, turn OFF the power and ON again.		

## (2) Failure in Operation

This section describes the causes and corrective actions in case the operation has not been successfully completed.

### ■ If “NO-OP” is shown

Probable Cause	Corrective Actions
The main circuit power supply was OFF.	Turn ON the main circuit power supply.
An alarm or warning occurred.	Remove the cause of the alarm or the warning.
Overtraveling occurred.	Remove the cause of the overtravel.
Gain setting 2 was selected by gain switching.	Turn OFF the automatic gain switching.
The HWBB function operated.	Cancel the HWBB function.

### ■ If “Error” is shown

Error	Probable Cause	Corrective Actions
The gain adjustment was not successfully completed.	Machine vibration is occurring or the positioning completed signal (/COIN) is repeatedly turning ON and OFF.	<ul style="list-style-type: none"> <li>• Increase the set value for Pn522.</li> <li>• Change the mode from 2 to 3.</li> <li>• If machine vibration occurs, suppress the vibration with the anti-resonance control adjustment function and the vibration suppression function.</li> </ul>
The positioning completed signal (/COIN) did not turn ON within approximately 10 seconds after positioning adjustment was completed.	The positioning completed width is too narrow or the proportional control (P control) is being used.	<ul style="list-style-type: none"> <li>• Increase the set value for Pn522.</li> <li>• If P control is used, turn OFF the /P-CON signal.</li> </ul>

### (3) Related Functions

This section describes the functions related to the advanced autotuning by reference.

#### ■ Notch Filter

Usually, set this function to Auto Setting. (The notch filter is factory-set to Auto Setting.)  
If this function is set to Auto Setting, vibration will be detected automatically and the notch filter will be set.

Set this function to Not Auto Setting only if you do not change the notch filter setting before executing advanced autotuning by reference.

Parameter		Function	When Enabled	Classification
<b>Pn460</b>	n.□□□0	Does not set the 1st notch filter automatically using the utility function.	Immediately	Tuning
	n.□□□1	Sets the 1st notch filter automatically using the utility function. [Factory setting]		
	n.□0□□	Does not set the 2nd notch filter automatically using the utility function.		
	n.□1□□	Sets the 2nd notch filter automatically using the utility function. [Factory setting]		

#### ■ Anti-Resonance Control Adjustment Function

This function reduces low vibration frequency; which the notch filter does not detect.

Usually, set this function to Auto Setting. (The anti-resonance control is factory-set to Auto Setting.)  
When this function is set to Auto Setting, vibration will be automatically detected during advanced autotuning by reference and anti-resonance control will be automatically adjusted and set.

Parameter		Function	When Enabled	Classification
<b>Pn160</b>	n.□□0□	Does not use the anti-resonance control automatically using the utility function.	Immediately	Tuning
	n.□□1□	Uses the anti-resonance control automatically using the utility function. [Factory setting]		

#### ■ Vibration Suppression

The vibration suppression function suppresses transitional vibration at frequency as low as 1 to 100 Hz that is generated mainly when positioning if the machine stand vibrates.

Usually, set this function to Auto Setting. (The vibration suppression function is factory-set to Auto Setting.)  
When this function is set to Auto Setting, vibration will be automatically detected during advanced autotuning by reference and model following control with vibration suppression will be automatically adjusted and set.  
Set this function to Not Auto Setting only if you do not change the setting for model following control with vibration suppression before executing advanced autotuning by reference.

Note: This function uses model following control. Therefore, the function can be executed only if the mode is set to 2 or 3.

#### Related Parameters

Parameter		Function	When Enabled	Classification
<b>Pn140</b>	n.□0□□	Does not use the vibration suppression function automatically using the utility function.	Immediately	Tuning
	n.□1□□	Uses the vibration suppression function automatically using the utility function. [Factory setting]		

### ■ Friction Compensation

This function compensates for changes in the following conditions.

- Changes in the viscous resistance of the lubricant, such as the grease, on the sliding parts of the machine
- Changes in the load resistance resulting from fluctuations in the machine assembly
- Secular changes in the load resistance

Conditions to which friction compensation is applicable depend on the mode. The friction compensation setting in Pn408.3 applies when the mode is 1.

Friction Compensation Selection		Mode		
		Mode = 1	Mode = 2	Mode = 3
Pn408	n.0□□□ [Factory setting]	Adjusted without the friction compensation function.	Adjusted with the friction compensation function.	Adjusted with the friction compensation function.
	n.1□□□	Adjusted with the friction compensation function.		

### ■ Feedforward

 <b>IMPORTANT</b>	<ul style="list-style-type: none"> <li>• Model following control is used to make optimum feedforward settings in the servo. Therefore, model following control is not used from the host controller together with either the speed feedforward input or force feedforward input. An improper speed feedforward input or force feedforward input may result in overshooting.</li> </ul>
--	--

If Pn140 is set to the factory setting and the mode setting is changed to 2 or 3, the feedforward reference (Pn109) (refer to 5.9.1) will be lost.

The following settings are required if model following control is used from the host controller (through the Command Option Module) together with the speed feedforward input or force feedforward input.

Parameter	Function	When Enabled	Classification
Pn140	n.0□□□ [Factory setting]	Immediately	Tuning
	n.1□□□		



### 5.4.3 Related Parameters

The following parameters are set automatically by using advanced autotuning by reference. Manual adjustments are not required.

Parameter	Name
<b>Pn100</b>	Speed Loop Gain
<b>Pn101</b>	Speed Loop Integral Time Constant
<b>Pn102</b>	Position Loop Gain
<b>Pn121</b>	Friction Compensation Gain
<b>Pn123</b>	Friction Compensation Coefficient
<b>Pn124</b>	Friction Compensation Frequency Correction
<b>Pn125</b>	Friction Compensation Gain Correction
<b>Pn141</b>	Model Following Control Gain
<b>Pn143</b>	Model Following Control Bias (Forward Direction)
<b>Pn144</b>	Model Following Control Bias (Reverse Direction)
<b>Pn145</b>	Vibration Suppression 1 Frequency A
<b>Pn146</b>	Vibration Suppression 1 Frequency B
<b>Pn147</b>	Model Following Control Speed Feedforward Compensation
<b>Pn161</b>	Anti-Resonance Frequency
<b>Pn163</b>	Anti-Resonance Damping Gain
<b>Pn401</b>	Force Reference Filter Time Constant
<b>Pn408</b>	Notch Filter Selection/Friction Compensation Selection
<b>Pn409</b>	1st Notch Filter Frequency
<b>Pn40A</b>	1st Notch Filter Q Value
<b>Pn40C</b>	2nd Notch Filter Frequency
<b>Pn40D</b>	2nd Notch Filter Q Value

## 5.5 One-parameter Tuning (Fn203)

This section describes the adjustments with one-parameter tuning.

### 5.5.1 One-parameter Tuning

One-parameter tuning is used to manually make tuning level adjustments during operation with a position reference or speed reference input from the host controller.

One-parameter tuning enables automatically setting related servo gain settings to balanced conditions by adjusting one or two autotuning levels.

One-parameter tuning performs the following adjustments.

- Gains (e.g., position loop gain and speed loop gain)
- Filters (force reference filter and notch filter)
- Friction compensation
- Anti-resonance control

Refer to *5.5.4 Related Parameters* for parameters used for adjustments.

For information on how to input position references or speed references, refer to the manual of the connected command option module.

Perform one-parameter tuning if satisfactory responsiveness is not obtained with advanced autotuning or advanced autotuning by reference.

To fine-tune each servo gain after one-parameter tuning, refer to *5.8 Additional Adjustment Function*.



### CAUTION

- Vibration or overshooting may occur during adjustment. To ensure safety, perform one-parameter tuning in a state where the SERVOPACK can come to an emergency stop at any time.
- Be sure to set a suitable value for the mass ratio (Pn103) using advanced autotuning before one-parameter tuning is performed. If the setting greatly differs from the actual mass ratio, normal control of the SERVOPACK may not be possible, and vibration may result.

#### (1) Before Performing One-parameter Tuning

Check the following settings before performing one-parameter tuning.

- a) A message (NO-OP) indicating that no operations are possible will be displayed, if all of the following conditions are not met.
  - The tuning-less function must not be enabled.
  - Test without motor function must not be enabled. (Pn00C.0 = 0)
- b) Observe the following condition to ensure operation.
  - The write prohibited setting (Fn010) must not be set.
  - The tuning mode must be set to 0 or 1 in speed control.

#### (2) Usage Restrictions

The tuning mode is restricted to 0 or 1 if speed control is used.

## 5.5.2 One-parameter Tuning Procedure

The following procedure is used for one-parameter tuning.

Operation procedures will vary in accordance with the tuning mode being used.























- When the tuning mode is set to 0 with priority given to stability or when the tuning mode is set to 1 with priority given to responsiveness, refer to (1) *Setting the Tuning Mode to 0 or 1*.
- When the tuning mode is set to 2 or 3 for adjustments in positioning, refer to (2) *Setting the Tuning Mode to 2 or 3*.











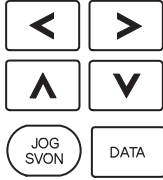





One-parameter tuning is performed from the Digital Operator (option) or SigmaWin+.

The operating procedure from the Digital Operator is described here.























For basic operations of the Digital Operator, refer to the  $\Sigma$ -V series *User's Manual, Operation of Digital Operator* (SIEP S800000 55).











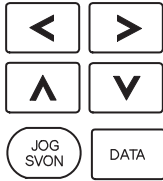





### (1) Setting the Tuning Mode to 0 or 1

Step	Display after Operation	Keys	Operation
1	<pre> RUN      —FUNCTION— Fn202: Ref-AAT Fn203: OnePrmTun Fn204: A-Vib Sup Fn205: Vib Sup           </pre>	  	<p>Press the  Key to view the main menu for the utility function mode.</p> <p>Use the  or  Key to move through the list, select Fn203.</p>
2	<pre> — Status Display — BB      —OnePrmTun— Pn103=00300           </pre>		<p>Press the  Key to display the mass ratio set in Pn103 at present. To change the setting, move the cursor with the  or  Key and change the set value with the  or  Key.</p> <p>Note: If the display does not switch and “NO-OP” is displayed, take corrective action after checking the items given in 5.5.1 (1) <i>Before Performing One-parameter Tuning</i>.</p>
3	<pre> BB      —OnePrmTun— Setting Tuning Mode = 2 Type = 2           </pre>		<p>Press the  Key to display the initial setting screen for one-parameter tuning.</p>
4	<pre> BB      —OnePrmTun— Setting Tuning Mode = 2 Type = 2           </pre>	  	<p>Press the ,  or  Key and set the items in steps 4-1 and 4-2.</p>
4-1	<p>■ <b>Tuning Mode Selection</b> Select the tuning Mode. Select the tuning mode 0 or 1. Tuning Mode = 0: Makes adjustments giving priority to stability. Tuning Mode = 1: Makes adjustments giving priority to responsiveness.</p>		
4-2	<p>■ <b>Type Selection</b> Select the type according to the machine element to be driven. If there is noise or the gain does not increase, better results may be obtained by changing the rigid type. Type = 1: For belt drive mechanisms. Type = 2: For ball screw drive mechanisms [Factory setting]. Type = 3: For rigid systems, such as a gear.</p>		
5			<p>Input a servo ON command from the host controller. The display will change from “BB” to “RUN.”</p>
6	<pre> RUN      —OnePrmTun— Pn100=0040.0 Pn101=0020.00 Pn102=0040.0           </pre>		<p>Press the  Key to display the set value.</p>

Step	Display after Operation	Keys	Operation
7	<pre> RUN  —OnePrmTun—       LEVEL = 0050 NF1  NF2   ARES </pre>		<p>Adjust the responsiveness by changing the level. After pressing the  Key, the present level will be displayed.</p> <p>Move the cursor with the  or  Keys and adjust the level with  or  Keys, and press the  Key.</p> <p>&lt;When vibration occurs&gt;</p> <p>The higher the level, the greater the responsiveness will be. If the value is too large, however, vibration will occur.</p> <p>If that occurs, press the  Key. The SERVOPACK will automatically detect the vibration frequencies and make notch filter or anti-resonance control settings.</p> <p>When the notch filter is set, “NF1” or “NF2” will be displayed on the bottom row.</p> <p>When anti-resonance control is set, “ARES” is displayed.</p> <p>Note: If the vibration is great, the vibration frequency will be detected even if the  Key is not pressed and a notch filter or anti-resonance control will be set.</p>
8	<pre> RUN  —OnePrmTun— Pn100=0050.0 Pn101=0016.0 Pn102=0050.0 </pre>		<p>Press the  Key. A confirmation screen is displayed after level adjustment.</p>
9	<pre> RUN  —OnePrmTun— Pn100=0050.0 Pn101=0016.0 Pn102=0050.0 </pre>		<ul style="list-style-type: none"> <li>• Press the  Key. The adjusted values will be written to the SERVOPACK. “DONE” will be displayed for approx. 2 seconds, and then “RUN” will be displayed.</li> <li>• Not to save the values set in step 7, press the  Key.</li> <li>• To readjust the responsiveness by changing the level before saving the values set in step 7, press the  Key. The screen in step 7 will appear.</li> </ul>
10	<pre> RUN  —FUNCTION— Fn202: Ref-AAT Fn203: OnePrmTun Fn204: A-Vib Sup Fn205: Vib Sup </pre>		<p>Press the  Key to complete the one-parameter tuning operation. The screen in step 1 will appear again.</p>

## (2) Setting the Tuning Mode to 2 or 3

Step	Display after Operation	Keys	Operation
1	<pre> RUN      —FUNCTION— Fn202:Ref-AAT Fn203:OnePrmTun Fn204:A-Vib Sup Fn205:Vib Sup           </pre>	  	<p>Press the  Key to view the main menu for the utility function mode.</p> <p>Use the  or  Key to move through the list, select Fn203.</p>
2	<pre> — Status Display BB —OnePrmTun— Pn103=00300           </pre>		<p>Press the  Key to display the mass ratio set in Pn103 at present. To change the setting, move the cursor with the  or  Key and change the set value with the  or  Key.</p> <p>Note: If the display does not switch and “NO-OP” is displayed, take corrective action after checking the items given in 5.5.1 (1) Before Performing One-parameter Tuning.</p>
3	<pre> BB —OnePrmTun— Setting Tuning Mode = 2 Type = 2           </pre>		<p>Press the  Key to display the initial setting screen for one-parameter tuning.</p>
4	<pre> BB —OnePrmTun— Setting Tuning Mode = 2 Type = 2           </pre>	  	<p>Press the ,  or  Key and set the items in steps 4-1 and 4-2.</p>
4-1	<p>■Tuning Mode Selection  Select the tuning Mode. Select the tuning mode 2 or 3.  Tuning Mode = 2: Enables the model following control, and makes adjustments for positioning.  Tuning Mode = 3: Enables the model following control, and makes adjustments for positioning, giving priority to overshooting suppression.</p>		
4-2	<p>■Type Selection  Select the type according to the machine element to be driven.  If there is noise or the gain does not increase, better results may be obtained by changing the rigid type.  Type = 1: For belt drive mechanisms.  Type = 2: For ball screw drive mechanisms [Factory setting].  Type = 3: For rigid systems, such as a gear.</p>		
5			<p>Input an servo ON command from the host controller. The display will change from “BB” to “RUN.”</p>
6	<pre> RUN      —OnePrmTun— Pn100=0040.0 Pn101=0020.00 Pn141=0050.0           </pre>		<p>Press the  Key to display the set value.</p>

Step	Display after Operation	Keys	Operation
7	<pre> RUN  —OnePrmTun— FF LEVEL=0050.0 FB LEVEL=0040.0  NF1  NF2  ARES </pre>		<p>Adjust the responsiveness by changing the FF and FB levels.</p> <p>Press the  Key to display the present level. Move the cursor with the  Key and change the set value with the  or  Keys.</p> <p>After the setting is changed, press the  Key.</p> <p>&lt;When vibration occurs&gt;</p> <p>The higher the level, the greater the responsiveness will be. If the value is too large, however, vibration will occur.</p> <p>If that occurs, press the  Key. The SERVOPACK will automatically detect the vibration frequencies and make notch filter or anti-resonance control settings. When the notch filter is set, “NF1” or “NF2” will be displayed on the bottom row.</p> <p>When the anti-resonance control is set, “ARES” is displayed.</p> <p>Notes:</p> <ul style="list-style-type: none"> <li>• If the vibration is great, the vibration frequency will be detected even if the  Key is not pressed and a notch filter or anti-resonance control will be set.</li> <li>• The higher the FF level, the shorter the positioning time will be. If the level is too high, however, overshooting will occur.</li> <li>• If the FF level is changed when the linear servomotor is stopped and no reference is input, this new value will be effective, and the linear servomotor’s responsiveness will be changed. To safely adjust the FF level, wait until all operations have been completed and check the responsiveness. When the FF level is changed largely, vibration may occur because the responsiveness is changed rapidly.</li> <li>• The message, “FF LEVEL”, blinks until the machine reaches the effective FF level. If the linear servomotor does not stop approximately 10 seconds after the FF level is changed, the setting is no longer effective and will automatically return to the previous setting.</li> <li>• If the vibration is too small, the SERVOPACK may not automatically detect the vibration frequencies. If so, press the  Key to forcibly start the detection.</li> </ul>
8	<pre> RUN  —OnePrmTun— Pn100=0040.0 Pn101=0020.00 Pn141=0050.0 NF1 </pre>		<p>Press the  Key. A confirmation screen is displayed after level adjustment.</p>
9	<pre> RUN  —OnePrmTun— Pn100=0040.0 Pn101=0020.00 Pn141=0050.0 NF1 </pre>		<ul style="list-style-type: none"> <li>• Press the  Key. The adjusted values will be written to the SERVOPACK, “DONE” will be displayed for approx. 2 seconds, and then “RUN” will be displayed.</li> <li>• Not to save the values set in step 7, press the  Key.</li> <li>• To readjust responsiveness by changing the level before saving the values set in step 7, press the  Key. The screen in step 7 will appear.</li> </ul>
10	<pre> RUN  —FUNCTION— Fn202:Ref-AAT Fn203:OnePrmTun Fn204:A-Vib Sup Fn205:Vib Sup </pre>		<p>Press the  Key to complete the one-parameter tuning operation. The screen in step 1 will appear again.</p>

### (3) Related Functions

This section describes functions related to one-parameter tuning.

#### ■ Notch Filter

Usually, set this function to Auto Setting. (The notch filter is factory-set to Auto Setting.)

If this function is set to Auto Setting, vibration will be detected automatically and the notch filter will be set.

Set this function to Not Auto Setting only if you do not change the notch filter setting before executing one-parameter tuning.

Parameter	Function	When Enabled	Classification
<b>Pn460</b>	n.□□□0	Does not set the 1st notch filter automatically using the utility function.	Immediately Tuning
	n.□□□1	Sets the 1st notch filter automatically using the utility function. [Factory setting]	
	n.□0□□	Does not set the 2nd notch filter automatically using the utility function.	
	n.□1□□	Sets the 2nd notch filter automatically using the utility function. [Factory setting]	

#### ■ Anti-Resonance Control Adjustment Function

This function reduces low vibration frequency; which the notch filter does not detect.

Usually, set this function to Auto Setting. (The anti-resonance control is factory-set to Auto Setting.)

When this function is set to Auto Setting, vibration will be automatically detected during one-parameter tuning and anti-resonance control will be automatically adjusted and set.

Parameter	Function	When Enabled	Classification
<b>Pn160</b>	n.□□0□	Does not use the anti-resonance control automatically using the utility function.	Immediately Tuning
	n.□□1□	Uses the anti-resonance control automatically using the utility function. [Factory setting]	

“ARES” will blink on the digital operator when anti-resonance control adjustment function is set.

```

RUN    -OnePrmTun-
FF LEVEL = 0050
FB LEVEL = 0040

NF1 NF2  ARES

```

### ■ Friction Compensation

This function compensates for changes in the following conditions.

- Changes in the viscous resistance of the lubricant, such as the grease, on the sliding parts of the machine
- Changes in the load resistance resulting from fluctuations in the machine assembly
- Secular changes in the load resistance

Conditions to which friction compensation is applicable depend on the tuning mode. The friction compensation setting in Pn408.3 applies when the mode is 0 or 1.

Friction Compensation Selecting		Mode			
		Tuning Mode = 0	Tuning Mode = 1	Tuning Mode = 2	Tuning Mode = 3
Pn408	n.0□□□ [Factory setting]	Adjusted without the friction compensation function.	Adjusted without the friction compensation function.	Adjusted with the friction compensation function.	Adjusted with the friction compensation function.
	n.1□□□	Adjusted with the friction compensation function.	Adjusted with the friction compensation function.		

### ■ Feedforward

 <b>IMPORTANT</b>	<ul style="list-style-type: none"> <li>• Model following control is used to make optimum feedforward settings in the servo. Therefore, model following control from the host controller is not used together with either the speed feedforward input or force feedforward input. An improper speed feedforward input or force feedforward input may result in overshooting.</li> </ul>
--	--

If Pn140 is set to the factory setting and the mode setting is changed to 2 or 3, the feedforward gain (Pn109) (refer to 5.9.1) will be lost.

The following settings are required if model following control is used from the host controller (through the Command Option Module) together with speed feedforward input or force feedforward input.

Parameter	Function	When Enabled	Classification
Pn140	n.0□□□ [Factory setting]	Immediately	Tuning
	n.1□□□		



### 5.5.3 One-parameter Tuning Example

The following procedure is used for one-parameter tuning on the condition that the tuning mode is set to 2, or 3. This mode is used to reduce positioning time.

Step	Measuring Instrument Display Example	Operation
1		<p>Measure the positioning time after setting the mass ratio (Pn103) correctly. Tuning will be completed if the specifications are met here. Save the tuning results in the SERVOPACK.</p>
2		<p>The positioning time will become shorter if the FF level is increased. The tuning will be completed if the specifications are met. Save the tuning results in the SERVOPACK. If overshooting occurs before the specifications are met, go to step 3.</p>
3		<p>Overshooting will be reduced if the FB level is increased. If the overshooting is solved, go to step 4.</p>
4		<p>The graph shows overshooting generated with the FF level increased in step 3. In this state, the overshooting occurs, but the positioning setting time is short. The tuning will be completed if the specifications are met. Save the adjustment results in the SERVOPACK. If overshooting occurs before the specifications are met, repeat steps 3 and 4. If vibration occurs before the overshooting is eliminated, suppress the vibration by the notch filter and anti-resonance control. Note: The vibration frequencies may not be detected if the vibration is too small. If that occurs, press the  Key to forcibly detect the vibration frequencies.</p>
5		<p>Save the adjustment results in the SERVOPACK.</p>

### 5.5.4 Related Parameters

The following parameters are set automatically by using one-parameter tuning. Manual adjustments are not required.

Parameter	Name
<b>Pn100</b>	Speed Loop Gain
<b>Pn101</b>	Speed Loop Integral Time Constant
<b>Pn102</b>	Position Loop Gain
<b>Pn121</b>	Friction Compensation Gain
<b>Pn123</b>	Friction Compensation Coefficient
<b>Pn124</b>	Friction Compensation Frequency Correction
<b>Pn125</b>	Friction Compensation Gain Correction
<b>Pn141</b>	Model Following Control Gain
<b>Pn143</b>	Model Following Control Bias (Forward Direction)
<b>Pn144</b>	Model Following Control Bias (Reverse Direction)
<b>Pn147</b>	Model Following Control Speed Feedforward Compensation
<b>Pn161</b>	Anti-Resonance Frequency
<b>Pn163</b>	Anti-Resonance Damping Gain
<b>Pn401</b>	Force Reference Filter Time Constant
<b>Pn408</b>	Notch Filter Selection/Friction Compensation Selection
<b>Pn409</b>	1st Notch Filter Frequency
<b>Pn40A</b>	1st Notch Filter Q Value
<b>Pn40C</b>	2nd Notch Filter Frequency
<b>Pn40D</b>	2nd Notch Filter Q Value

## 5.6 Anti-resonance Control Adjustment Function (Fn204)

This section describes how to adjust the anti-resonance control.

### 5.6.1 Anti-resonance Control Adjustment Function

The anti-resonance control adjustment function increases the effectiveness of the vibration suppression after one-parameter tuning.

The anti-resonance control adjustment function (Pn204) is an effective way to control the frequent vibration between 100 Hz and 1000 Hz when the control gain increases.

Perform one-parameter tuning (Fn203) or use another method to increase the responsiveness after performing this function. If the vibration gain is increased with one-parameter tuning performed, vibration may result again. If that occurs, perform this function again to fine-tune the settings.

#### CAUTION

- If this function is executed, related parameters will be set automatically. Therefore, there will be a large response change after this function is enabled or disabled. Enable the function in a state where the machine can come to an emergency stop at any time to ensure the safety operation of the machine.
- Be sure to set a suitable value for the mass ratio (Pn103) using advanced autotuning before executing the anti-resonance control adjustment function. If the setting greatly differs from the actual mass ratio, normal control of the SERVOPACK may not be possible, and vibration may result.

#### IMPORTANT

- This function detects vibration between 100 and 1,000 Hz. Vibration will not be detected for frequencies outside of this range, and instead, "F----" will be displayed. If that occurs, use one-parameter tuning with tuning mode 2 selected to automatically set a notch filter or use the vibration suppression function (Fn205).
- Vibration can be reduced more effectively by increasing the present damping gain (Pn163). The amplitude of vibration may become larger if the damping gain is excessively high. Increase the vibration gain from about 0% to 200% in 10% increments while checking the effect of vibration reduction. If the effect of vibration reduction is still insufficient at a gain of 200%, cancel the setting, and lower the control gain using a different method, such as one-parameter tuning.

#### (1) Before Performing Anti-Resonance Control Adjustment Function

Check the following settings before performing anti-resonance control adjustment function.

- a) A message (NO-OP) indicating that no operations are possible will be displayed, if all of the following conditions are not met.
  - The tuning-less function must not be enabled.
  - Test without motor function must not be enabled. (Pn00C.0=0)
  - Force control must not be selected.
- b) Observe the following condition to ensure operation.
  - The write prohibited setting (Fn010) must not be set.

## 5.6.2 Anti-resonance Control Adjustment Function Operating Procedure

With this function, a control reference is sent, and the function is executed while vibration is occurring.

Anti-resonance control adjustment function is performed from the Digital Operator (option) or SigmaWin+.















The following three methods can be used for the anti-resonance control adjustment function. Select and use the best method.











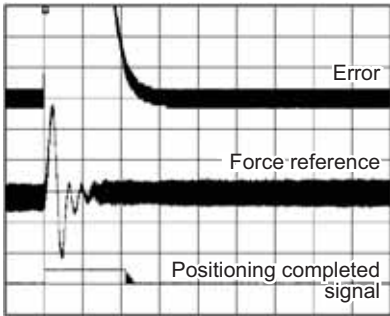









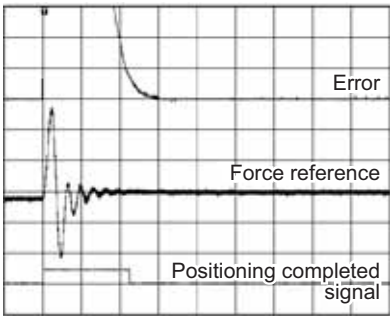



1. With Undetermined Vibration Frequency Before Adjusting the Anti-resonance Control
2. With Determined Vibration Frequency Before Adjusting the Anti-resonance Control
3. For Fine-tuning After Adjusting the Anti-resonance Control

The operating procedures from the Digital Operator are described here.























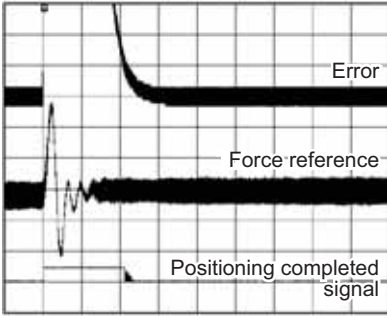

Refer to the  *$\Sigma V$  series User's Manual, Operation of Digital Operator (SIEP S800000 55)* for basic key operations of the Digital Operator.











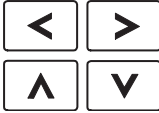

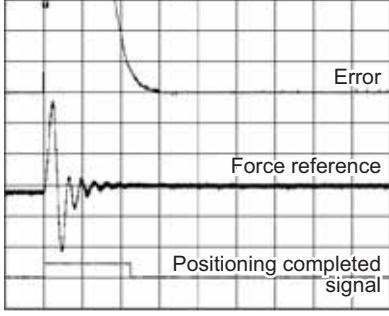

### (1) With Undetermined Vibration Frequency Before Adjusting the Anti-resonance Control

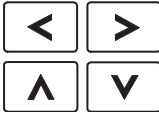
Step	Display after Operation	Keys	Operation
1	<pre> RUN      --FUNCTION-- Fn203: OnePrmTun Fn204: A-Vib Sup Fn205: Vib Sup Fn206: Easy FFT           </pre>	  	<p>Press the  Key to view the main menu for the utility function mode.</p> <p>Use the  or  Key to move through the list, select Fn204.</p>
2	<pre> Status Display RUN --Vib Sup-- Tuning Mode = 0           </pre>		<p>Press the  Key to display the initial setting screen for tuning mode.</p> <p>Note: If the display does not switch and "NO-OP" is displayed, take corrective action after checking the items given in 5.6.1 (1) Before Performing Anti-resonance Control Adjustment Function.</p>
3	<pre> RUN --Vib Sup-- Tuning Mode = 0           </pre>	 	<p>Press the  or  Key and select the tuning mode "0".</p>
4	<pre> RUN --Vib Sup-- freq = ---- Hz damp = 0000           </pre>		<p>Press the  Key while "Tuning Mode = 0" is displayed. The screen shown on the left will appear. The detection of vibration frequencies will start and "freq" will blink. Return to step 3 if vibration is not detected.</p> <p>Note: If a vibration is not detected even though a vibration has occurred, lower the vibration detection sensibility (Pn311). When this parameter is lowered, the detection sensitivity will be increased. Vibration may not be detected accurately if too small value is set.</p>

































Step	Display after Operation	Keys	Operation
5	<pre> RUN      - Vib Sup - freq = 0400 Hz damp = 0000                     </pre>		<p>The vibration frequency will be displayed if vibration is detected.</p>  <p>Waveform</p>
6	<pre> RUN      - Vib Sup - freq = 0400 Hz damp = 0000_                     </pre>		<p>Press the  Key. The cursor will move to “damp,” and the blinking of “freq” will stop.</p>
7	<pre> RUN      - Vib Sup - freq = 0400 Hz damp = 0120_                     </pre>	   	<p>Move the cursor with the  or  Keys and press the  or  Keys to set the damping gain.</p>  <p>Waveform</p> <p>Note:                  Increase the damping gain from about 0% to 200% in 10% increments while checking the effect of vibration reduction. If vibration reduction is still insufficient at a gain of 200%, cancel the setting, and lower the control gain by using a different method, such as one-parameter tuning.</p>
8	<pre> RUN      - Vib Sup - freq = 0400 Hz damp = 0120                     </pre>		<p>If fine-tuning of the frequency is necessary, press the  Key. The cursor will move from “damp” to “freq”.</p> <p>If fine-tuning is not necessary, skip step 9 and go to step 10.</p>
9	<pre> RUN      - Vib Sup - freq = 0420 Hz damp = 0120                     </pre>	   	<p>Move the cursor with the  or  Keys and press the  or  Keys to fine-tune the frequency.</p>
10	<pre> RUN      - Vib Sup - freq = 0420 Hz damp = 0120                     </pre>		<p>Press  Key to save the settings. “DONE” will blink for approx. 2 seconds and “RUN” will be displayed.</p>
11	<pre> RUN      -FUNCTION- Fn203: OnePrmTun Fn204: A-Vib Sup Fn205: Vib Sup Fn206: Easy FFT                     </pre>		<p>Press the  Key to complete the anti-resonance control adjustment function. The screen in step 1 will appear again.</p>

(2) With Determined Vibration Frequency Before Adjusting the Anti-resonance Control

Step	Display after Operation	Keys	Operation
1	<pre> RUN      -FUNCTION- Fn203: OnePrmTun Fn204: A-Vib Sup Fn205: Vib Sup Fn206: Easy FFT                     </pre>	  	<p>Press the  Key to view the main menu for the utility function mode.</p> <p>Use the  or  Key to move through the list, select Fn204.</p>
2	<pre> RUN      - Vib Sup - Tuning Mode = 0                     </pre>		<p>Press the  Key to display the initial setting screen for tuning mode.</p> <p>Note: If the display does not switch and “NO-OP” is displayed, take corrective action after checking the items given in 5.6.1 (1) Before Performing Anti-Resonance Control Adjustment Function.</p>
3	<pre> RUN      -FUNCTION- Tuning Mode = 1                     </pre>	 	<p>Press the  or  Key and select the tuning mode “1”.</p>
4	<pre> RUN      - Vib Sup - freq = 0100 Hz damp = 0000                     </pre>		<p>Press the  Key while “Tuning Mode = 1” is displayed. The screen shown on the left will appear and “freq” will blink.</p>  <p style="text-align: center;">Waveform</p>
5	<pre> RUN      - Vib Sup - freq = 0100 Hz damp = 0000                     </pre>	   	<p>Move the cursor with the  or  Keys and press the  or  Keys to adjust the frequency.</p>
6	<pre> RUN      - Vib Sup - freq = 0400 Hz damp = 000<u>0</u>                     </pre>		<p>Press the  Key. The cursor will move to “damp”.</p>

Step	Display after Operation	Keys	Operation
7	<pre> RUN      - Vib Sup - freq = 0400 Hz damp = 0020                     </pre>		<p>Move the cursor with the  or  Key and press the  or  Key to adjust the damping gain.</p>  <p>Waveform</p> <p>Note: Increase the damping gain from about 0% to 200% in 10% increments while checking the effect of vibration reduction. If vibration reduction is still insufficient at a gain of 200%, cancel the setting, and lower the control gain by using a different method, such as one-parameter tuning.</p>
8	<pre> RUN      - Vib Sup - freq = 0400 Hz damp = 0120                     </pre>		<p>If fine-tuning of the frequency is necessary, press the  Key. The cursor will move from “damp” to “freq”.</p> <p>If fine-tuning is not necessary, skip step 9 and go to step 10.</p>
9	<pre> RUN      - Vib Sup - freq = 0400 Hz damp = 0120                     </pre>		<p>Move the cursor with  or  Keys and press the  or  Keys to fine-tune the frequency.</p>
10	<pre> RUN      - Vib Sup - freq = 0400 Hz damp = 0120                     </pre>		<p>Press  Key to save the settings.</p> <p>“DONE” will blink for approx. 2 seconds and “RUN” will be displayed.</p>
11	<pre> RUN      -FUNCTION- Fn203: OnePrmTun Fn204: A-Vib Sup Fn205: Vib Sup Fn206: Easy FFT                     </pre>		<p>Press the  Key to complete the anti-resonance control adjustment function. The screen in step 1 will appear again.</p>

## (3) For Fine-tuning After Adjusting the Anti-resonance Control

Step	Display after Operation	Keys	Operation
1	<pre> RUN      —FUNCTION— Fn203: OnePrmTun Fn204: A-Vib Sup Fn205: Vib Sup Fn206: Easy FFT </pre>	  	<p>Press the  Key to view the main menu for the utility function mode.</p> <p>Use the  or  Key to move through the list, select Fn204.</p>
2	<pre> RUN      —FUNCTION— Tuning Mode = 1 </pre>		<p>Press the  Key to display the “Tuning Mode = 1” as shown on the left.</p> <p>Note: If the display does not switch and “NO-OP” is displayed, take corrective action after checking the items given in 5.6.1 (1) Before Performing Anti-Resonance Control Adjustment Function.</p>
3	<pre> RUN      —Vib Sup— freq = 0400 Hz damp = 0120 </pre>		<p>Press the  Key while “Tuning Mode = 1” is displayed. The screen shown on the left will appear and “damp” will blink.</p>
4	<pre> RUN      —Vib Sup— freq = 0400 Hz damp = 0150 </pre>	   	<p>Move the cursor with the  or  Keys and press the  or  Keys to set the damping gain.</p> <p>Note: Increase the damping gain from about 0% to 200% in 10% increments while checking the effect of vibration reduction. If vibration reduction is still insufficient at a gain of 200%, cancel the setting, and lower the control gain by using a different method, such as one-parameter tuning.</p>
5	<pre> RUN      —Vib Sup— freq = 0400 Hz damp = 0150 </pre>		<p>If fine-tuning of the frequency is necessary, press the  Key. The cursor will move from “damp” to “freq”.</p> <p>If fine-tuning is not necessary, skip step 6 and go to step 7.</p>
6	<pre> RUN      —Vib Sup— freq = 0420 Hz damp = 0150 </pre>	   	<p>Select a digit with  or  Keys, and press the  or  Keys to fine-tune the frequency.</p>
7	<pre> RUN      —Vib Sup— freq = 0420 Hz damp = 0150 </pre>		<p>Press  Key to save the settings in the SERVO-PACK.</p> <p>“DONE” will blink for approx. 2 seconds and “RUN” will be displayed.</p>
8	<pre> RUN      —FUNCTION— Fn203: OnePrmTun Fn204: A-Vib Sup Fn205: Vib Sup Fn206: Easy FFT </pre>		<p>Press the  Key to complete the anti-resonance control adjustment function. The screen in step 1 will appear again.</p>

## 5.6.3 Related Parameters

Pn160 and Pn161 are set automatically. The other parameters are not set automatically but the respective set values in the parameters will apply.

Parameter	Name
<b>Pn160</b>	Anti-resonance Control Related Switch
<b>Pn161</b>	Anti-resonance Frequency
<b>Pn162</b>	Anti-resonance Gain Compensation
<b>Pn163</b>	Anti-resonance Damping Gain
<b>Pn164</b>	Anti-resonance Filter Time Constant 1 Compensation
<b>Pn165</b>	Anti-resonance Filter Time Constant 2 Compensation



## 5.7 Vibration Suppression Function (Fn205)

This section describes the vibration suppression function.

### 5.7.1 Vibration Suppression Function

The vibration suppression function suppresses transitional vibration at frequency as low as 1 to 100 Hz that is generated mainly when positioning if the machine stand vibrates.

This function is set automatically when advanced autotuning or advanced autotuning by reference is executed. In most cases, this function is not necessary. Use this function only if fine-tuning is required or readjustment is required as a result of a failure to detect vibration.

Perform one-parameter tuning (Fn203) or use another method to increase the responsiveness after performing this function.

#### CAUTION

- If this function is executed, related parameters will be set automatically. Therefore, the response before and after using this function may vary greatly. Enable the function in a state where the machine can come to an emergency stop at any time to ensure the safety operation of the machine.
- Be sure to set a suitable value for the mass ratio (Pn103) using advanced autotuning before executing this function. If the setting greatly differs from the actual mass ratio, normal control of the SERVOPACK may not be possible, and vibration may result.



- This function detects vibration frequency between 1 to 100 Hz. Vibration will not be detected for frequencies outside of this range, and instead, "F-----" will be displayed.
- Frequency detection will not be performed if no vibration results from position error or the vibration frequencies are outside the range of detectable frequencies. If so, use a device, such as a displacement sensor or vibration sensor, to measure the vibration.
- If vibration frequencies automatically detected are not suppressed, the actual frequency and the detected frequency may differ. Fine-tune the detected frequency if necessary.

#### (1) Before Performing Vibration Suppression Function

Check the following settings before performing the vibration suppression function.

- a) A message (NO-OP) indicating that no operations are possible will be displayed, if all of the following conditions are not met.
  - The control must be set to position control.
  - The tuning-less function must not be enabled.
  - Test without motor function must not be enabled. (Pn00C.0 = 0)
- b) Observe the following condition to ensure operation.
  - The write prohibited setting (Fn010) must not be set.

#### (2) Items Influencing Performance

If continuous vibration occurs when the linear servomotor is running, the vibration suppression function cannot be used to suppress the vibration effectively. If the result is not satisfactory, perform anti-resonance control adjustment function (Fn204) or one-parameter tuning (Fn203).

#### (3) Detection of Vibration Frequencies

No frequency detection may be possible if the vibration does not appear as a position error or the vibration resulting from the position error is too small.

The detection sensitivity can be adjusted by changing the setting for the remained vibration detection width (Pn560) which is set in accordance with the value of the positioning completed width (Pn522). Perform the detection of vibration frequencies after adjusting the remained vibration detection width (Pn560).

Pn560	Remained Vibration Detection Width <span style="border: 1px solid black; padding: 2px;">Position</span>				Classification
	Setting Range	Setting Unit	Factory Setting	When Enabled	
	1 to 3000	0.1%	400	Immediately	Setup

Note: Use a set value of 10% as a guideline. The smaller the set value is, the higher the detection sensitivity will be. If the value is too small, however, the vibration may not be detected accurately.

Vibration frequencies automatically detected may vary more or less during each positioning operation. Perform positioning several times and make adjustments while checking the effect of vibration suppression.

## 5.7.2 Vibration Suppression Function Operating Procedure

The following procedure is used for vibration suppression function.

Vibration suppression function is performed from the Digital Operator (option) or SigmaWin+.

The operating procedure from the Digital Operator is described here.

For basic operations of the Digital Operator, refer to the *Σ-V series User's Manual, Operation of Digital Operator* (SIEP S800000 55).







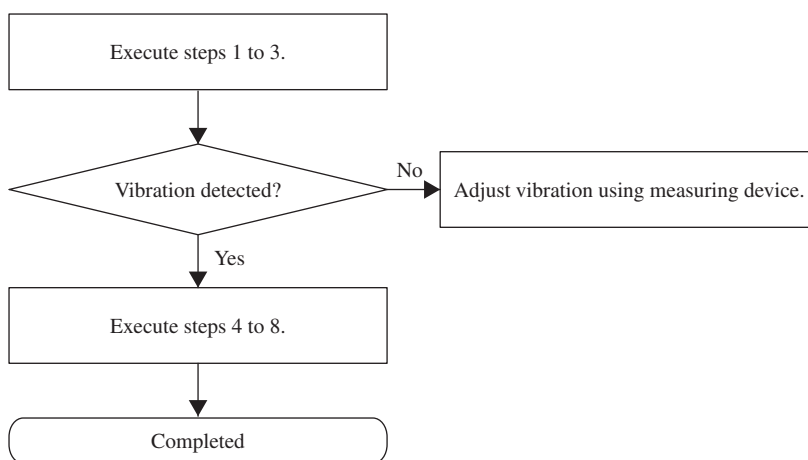











Note: If this function is aborted by pressing the  Key, the SERVOPACK will continue operating until the linear servomotor comes to a stop. After the linear servomotor stops, the set value will return to the previous value.

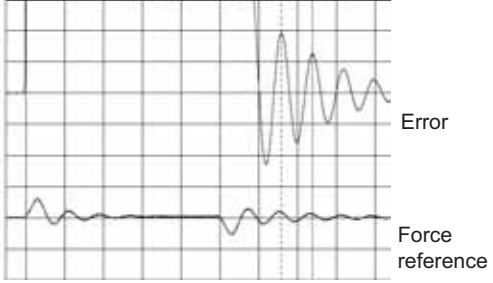





The operation flow of the vibration suppression function is shown below.

### (1) Operation Flow

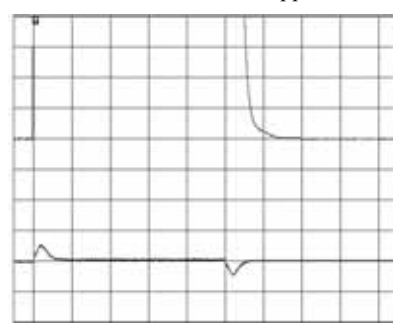

(2) Operating Procedure

Step	Display after Operation	Keys	Operation
1	Input a control reference and take the following steps while repeating positioning.		
2	<pre> RUN      -FUNCTION- Fn204:A-Vib Sup Fn205:Vib Sup Fn206:Easy FFT Fn207:V-Monitor                     </pre>	  	<p>Press the  Key to view the main menu for the utility function mode.</p> <p>Use the  or  Key to move through the list, select Fn205.</p>
3	<pre> RUN      -Vib Sup- Measure f=-----Hz Setting f=050.0Hz                     </pre>		<p>Press the  Key. The display shown on the left will appear.</p> <p>Measure f: Measurement frequency                      Setting f: Setting frequency [Factory-set to the set value for Pn145]</p> <p>Notes:</p> <ul style="list-style-type: none"> <li>If the setting frequency and actual operating frequency are different, "Setting" will blink. The detected vibration frequency will be displayed.</li> </ul> <pre> RUN      -Vib Sup- Measure f=010.4Hz Setting f=050.0Hz                     </pre> <ul style="list-style-type: none"> <li>Frequency detection will not be performed if there is no vibration or the vibration frequency is outside the range of detectable frequencies. The following screen will be displayed if vibration is not detected. If the vibration frequencies are not detected, prepare a means of detecting and measuring the vibration. When the vibration frequencies are measured, go to step 5 and manually set the measured vibration frequency.</li> </ul> <pre> RUN      -Vib Sup- Measure f=-----Hz Setting f=050.0Hz                     </pre>
4	<pre> RUN      -Vib Sup- Measure f=010.4Hz Setting f=010.4Hz                     </pre>		<p>Press the  Key. The displayed "Measure f" value will be displayed as the "Setting f" value as well.</p>  <p style="text-align: center;">Waveform</p>
5	<pre> RUN      -Vib Sup- Measure f=010.4Hz Setting f=012.4Hz                     </pre>	   	<p>If the vibration is not completely suppressed, press the  or  Key to move the cursor, and press the  or  Key to fine-tune the frequency. Skip this step and go to step 7 if the fine-tuning of the frequency is not necessary.</p> <p>Note:                      If the setting frequency and actual operating frequency are different, "Setting" will blink.</p>

Step	Display after Operation	Keys	Operation
6	<pre> RUN      -Vib Sup- Measure f=010.4Hz Setting f=012.4Hz                     </pre>		<p>Press the  Key. The “Setting f” will change to usual display and the frequency currently displayed will be set for the vibration suppression function.</p> 
7	<pre> RUN      -Vib Sup- Measure f-----Hz Setting f=012.4Hz                     </pre>		<p>Press the  Key to save the settings in the SER-VOPACK.  “DONE” will blink for approx. 2 seconds and “RUN” will be displayed.</p>
8	<pre> RUN      -FUNCTION- Fn204 Fn205 Fn206 Fn207                     </pre>		<p>Press the  Key to complete the vibration suppression function. The screen in step 1 will appear again.</p>



**IMPORTANT**

No settings related to the vibration suppression function will be changed during operation.

If the linear servomotor does not stop approximately 10 seconds after the setting changes, a timeout error will result and the previous setting will be enabled again.

The vibration suppression function will be enabled when the parameter is set in step 6. The linear servomotor response, however, will change when the linear servomotor comes to a stop with no reference input.

(3) Related Function

This section describes a function related to vibration suppression.

■ Feedforward



**IMPORTANT**

- Model following control is used to make optimum feedforward settings in the servo. Therefore, model following control from the host controller is not used together with either the speed feedforward input or force feedforward input. An improper speed feedforward input or force feedforward input may result in overshooting.

If this function is performed, the feedforward reference (Pn109) will be ignored because model following control will be enabled.

The following settings are required if model following control is used from the host controller (through the command option module) together with speed feedforward input or force feedforward input.

Parameter	Function	When Enabled	Classification
<b>Pn140</b>	n.0□□□	Immediately	Tuning
	n.1□□□		

### 5.7.3 Related Parameters

The following parameters are set automatically by using vibration suppression function. Manual adjustments are not required.

Parameter	Name
<b>Pn140</b>	Model Following Control Related Switch
<b>Pn141</b>	Model Following Control Gain
<b>Pn145</b>	Vibration Suppression 1 Frequency A
<b>Pn146</b>	Vibration Suppression 1 Frequency B

## 5.8 Additional Adjustment Function

This section describes the functions that can be used for additional fine tuning after making adjustments with advanced autotuning, advanced autotuning by references, or one-parameter tuning.

- Switching gain settings
- Friction compensation
- Current Control Mode Selection
- Current Gain Level Setting
- Speed Detection Method Selection

### 5.8.1 Switching Gain Settings

Two gain switching functions are available, manual switching and automatic switching. The manual switching function uses an external input signal to switch gains, and the automatic switching function switches gains automatically.

Parameter		Function	When Enabled	Classification
Pn139	n.□□□0	Manual gain switching [Factory setting]	Immediately	Tuning
	n.□□□2	Automatic gain switching		

Note: n.□□□1 is reserved. Do not set.

For the gain combinations for switching, refer to (1) *Gain Combinations for Switching*.

For the manual gain switching, refer to the manual of the connected command option module.

For the automatic gain switching, refer to (3) *Automatic Gain Switching*.

#### (1) Gain Combinations for Switching

Setting	Speed Loop Gain	Speed Loop Integral Time Constant	Position Loop Gain	Force Reference Filter	Model Following Control Gain	Model Following Control Gain Compensation	Friction Compensation Gain
Gain Setting 1	Pn100 Speed Loop Gain	Pn101 Speed Loop Integral Time Constant	Pn102 Position Loop Gain	Pn401 Force Reference Filter Time Constant	Pn141* Model Following Control Gain	Pn142* Model Following Control Gain Compensation	Pn121 Friction Compensation Gain
Gain Setting 2	Pn104 2nd Speed Loop Gain	Pn105 2nd Speed Loop Integral Time Constant	Pn106 2nd Position Loop Gain	Pn412 1st Step 2nd Force Reference Filter Time Constant	Pn148* 2nd Model Following Control Gain	Pn149* 2nd Model Following Control Gain Compensation	Pn122 2nd Gain for Friction Compensation

\* The switching gain settings for the model following control gain and the model following control gain compensation are available only for manual gain switching. To enable the gain switching of these parameters, a gain switching input signal must be sent, and the following conditions must be met.

- No command being executed.
- Motor having been completely stopped.

If these conditions are not satisfied, these parameters will not be switched although the other parameters shown in this table will be switched.

#### (2) Manual Gain Switching

Manual gain switching uses a command (/G\_SEL) from the Command Option Module to switch between gain setting 1 and gain setting 2.

For details, refer to the manual of the connected Command Option Module.

### (3) Automatic Gain Switching

Automatic gain switching is performed under the following settings and conditions.

Parameter Setting	Switching Setting	Setting	Switching Wait Time	Switching Time
<b>Pn139 = n.□□□2 (Automatic Switching)</b>	Condition A established.	Gain Setting 1 to Gain Setting 2	Gain Switching Waiting Time 1 Pn135	Gain Switching Time 1 Pn131
	Condition A not established.	Gain Setting 2 to Gain Setting 1	Gain Switching Waiting Time 2 Pn136	Gain Switching Time 2 Pn132

Select one of the following setting for switching condition A.

Parameter		Switching Condition A		When Enabled	Classification
		Position Control	Other than Position Control		
<b>Pn139</b>	n.□□0□	Positioning completed signal (/COIN) ON	Fixed in gain setting 1	Immediately	Tuning
	n.□□1□	Positioning completed signal (/COIN) OFF	Fixed in gain setting 2		
	n.□□2□	NEAR signal (/NEAR) ON	Fixed in gain setting 1		
	n.□□3□	Near signal (/NEAR) OFF	Fixed in gain setting 2		
	n.□□4□	No output for position reference filter and reference pulse input OFF	Fixed in gain setting 1		
	n.□□5□	Position reference pulse input ON	Fixed in gain setting 2		

Automatic switching pattern 1 (Pn139.0 = 2)

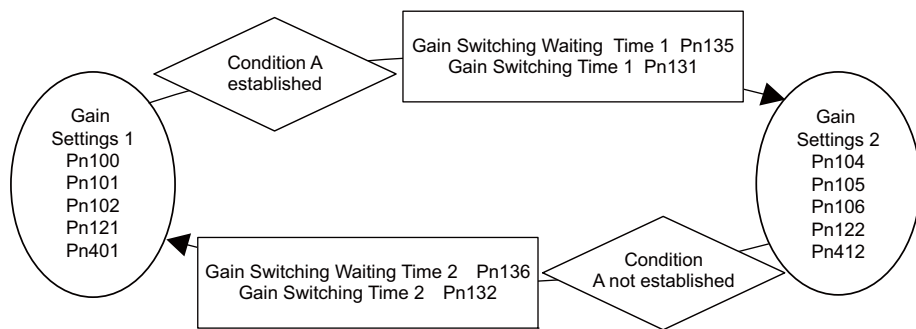

### ■ Relationship between the Gain Switching Waiting Time and the Switching Time Constant

In this example, the “positioning completion signal (/COIN) ON” condition is set as condition A for automatic gain switching. The position loop gain is switched from the value in Pn102 (Position Loop Gain) to the value in Pn106 (2nd Position Loop Gain). When the /COIN signal goes ON, the switching operation begins after the waiting time set in Pn135. The switching operation changes the position loop gain linearly from Pn102 to Pn106 over the switching time set in Pn131.

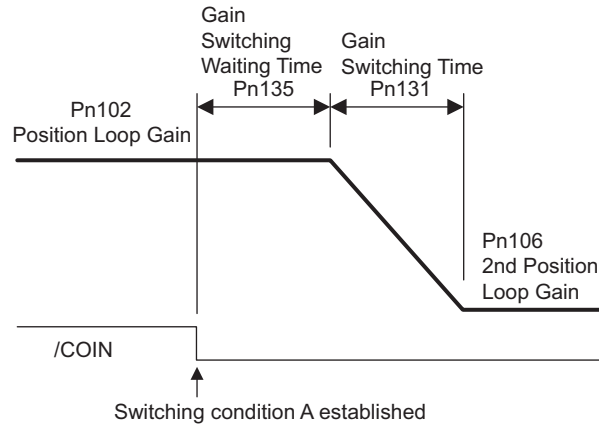

Note: Automatic gain switching is available in the PI and I-P controls. (Pn10B)



## (4) Related Parameters

Pn100	Speed Loop Gain <span style="float:right">Speed Position</span>				Classification
	Setting Range	Setting Unit	Factory Setting	When Enabled	
	10 to 20000	0.1 Hz	400	Immediately	Tuning
Pn101	Speed Loop Integral Time Constant <span style="float:right">Speed Position</span>				Classification
	Setting Range	Setting Unit	Factory Setting	When Enabled	
	15 to 51200	0.01 ms	2000	Immediately	Tuning
Pn102	Position Loop Gain <span style="float:right">Position</span>				Classification
	Setting Range	Setting Unit	Factory Setting	When Enabled	
	10 to 20000	0.1/s	400	Immediately	Tuning
Pn141	Model Following Control Gain <span style="float:right">Position</span>				Classification
	Setting Range	Setting Unit	Factory Setting	When Enabled	
	10 to 20000	0.1/s	500	Immediately	Tuning
Pn142	Model Following Control Gain Compensation <span style="float:right">Position</span>				Classification
	Setting Range	Setting Unit	Factory Setting	When Enabled	
	500 to 2000	0.1%	1000	Immediately	Tuning
Pn104	2nd Speed Loop Gain <span style="float:right">Speed Position</span>				Classification
	Setting Range	Setting Unit	Factory Setting	When Enabled	
	10 to 20000	0.1 Hz	400	Immediately	Tuning
Pn105	2nd Speed Loop Integral Time Constant <span style="float:right">Speed Position</span>				Classification
	Setting Range	Setting Unit	Factory Setting	When Enabled	
	15 to 51200	0.01 ms	2000	Immediately	Tuning
Pn106	2nd Position Loop Gain <span style="float:right">Position</span>				Classification
	Setting Range	Setting Unit	Factory Setting	When Enabled	
	10 to 20000	0.1/s	400	Immediately	Tuning
Pn121	Friction Compensation Gain <span style="float:right">Speed Position</span>				Classification
	Setting Range	Setting Unit	Factory Setting	When Enabled	
	10 to 1000	0.1%	100	Immediately	Tuning
Pn122	2nd Gain for Friction Compensation <span style="float:right">Speed Position</span>				Classification
	Setting Range	Setting Unit	Factory Setting	When Enabled	
	10 to 1000	1%	100	Immediately	Tuning
Pn148	2nd Model Following Control Gain <span style="float:right">Position</span>				Classification
	Setting Range	Setting Unit	Factory Setting	When Enabled	
	10 to 20000	0.1/s	500	Immediately	Tuning
Pn149	2nd Model Following Control Gain Compensation <span style="float:right">Position</span>				Classification
	Setting Range	Setting Unit	Factory Setting	When Enabled	
	500 to 2000	0.1 %	1000	Immediately	Tuning
Pn401	Force Reference Filter Time Constant <span style="float:right">Speed Position Force</span>				Classification
	Setting Range	Setting Unit	Factory Setting	When Enabled	
	0 to 65535	0.01 ms	100	Immediately	Tuning

<b>Pn412</b>	1st Step 2nd Force Reference Filter Time Constant <input type="checkbox"/> Speed <input type="checkbox"/> Position <input type="checkbox"/> Force				Classification
	Setting Range	Setting Unit	Factory Setting	When Enabled	
	0 to 65535	0.01 ms	100	Immediately	Tuning

## (5) Parameters for Automatic Gain Switching

<b>Pn131</b>	Gain Switching Time 1 <input type="checkbox"/> Position				Classification
	Setting Range	Setting Unit	Factory Setting	When Enabled	
	0 to 65535	1 ms	0	Immediately	Tuning
<b>Pn132</b>	Gain Switching Time 2 <input type="checkbox"/> Position				Classification
	Setting Range	Setting Unit	Factory Setting	When Enabled	
	0 to 65535	1 ms	0	Immediately	Tuning
<b>Pn135</b>	Gain Switching Waiting Time 1 <input type="checkbox"/> Position				Classification
	Setting Range	Setting Unit	Factory Setting	When Enabled	
	0 to 65535	1 ms	0	Immediately	Tuning
<b>Pn136</b>	Gain Switching Waiting Time 2 <input type="checkbox"/> Position				Classification
	Setting Range	Setting Unit	Factory Setting	When Enabled	
	0 to 65535	1 ms	0	Immediately	Tuning

## (6) Related Monitor

Monitor No. (Un)	Name	Value	Remarks
Un014	Effective gain monitor	1	For gain setting 1
		2	For gain setting 2

Note: When using the tuning-less function, gain setting 1 is enabled.

Parameter	Analog Monitor	Name	Output Value	Remarks
Pn006	n.□□0B	Active gain	1 V	Gain setting 1 is enabled.
Pn007			2 V	Gain setting 2 is enabled.

## 5.8.2 Friction Compensation

Friction compensation rectifies the viscous friction change and regular load change.

The factors causing load changes include grease viscosity resistance changes resulting from temperature changes in addition to viscous friction and regular load changes resulting from equipment variations and secular changes.

Friction compensation is automatically adjusted by the following settings.

1. The advanced autotuning level is set to mode 2 or 3.
2. The one-parameter tuning mode is set to 2 or 3.

Refer to the following description and make adjustments only if manual adjustment is required.

### (1) Required Parameter Settings

The following parameter settings are required to use friction compensation.

Parameter	Function			When Enabled	Classification	
<b>Pn408</b>	n.0□□□	Does not use friction compensation. [Factory setting]			Immediately	Setup
	n.1□□□	Uses friction compensation.				
<b>Pn121</b>	Friction Compensation Gain <span style="float:right">[Speed] [Position]</span>				Classification	
	Setting Range	Setting Unit	Factory Setting	When Enabled		
	10 to 1000	1 %	100	Immediately	Tuning	
<b>Pn123</b>	Friction Compensation Coefficient <span style="float:right">[Speed] [Position]</span>				Classification	
	Setting Range	Setting Unit	Factory Setting	When Enabled		
	0 to 100	1 %	0	Immediately	Tuning	
<b>Pn124</b>	Friction Compensation Frequency Correction <span style="float:right">[Speed] [Position]</span>				Classification	
	Setting Range	Setting Unit	Factory Setting	When Enabled		
	-10000 to 10000	0.1 Hz	0	Immediately	Tuning	
<b>Pn125</b>	Friction Compensation Gain Correction <span style="float:right">[Speed] [Position]</span>				Classification	
	Setting Range	Setting Unit	Factory Setting	When Enabled		
	1 to 1000	1 %	100	Immediately	Tuning	

## (2) Operating Procedure for Friction Compensation

The following procedure is used for friction compensation.

<b>CAUTION</b>
<p>Before using friction compensation, set the mass ratio (Pn103) as correctly as possible. If the wrong mass ratio is set, vibration may result.</p>

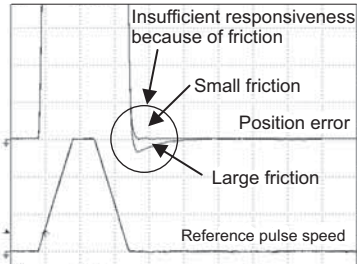
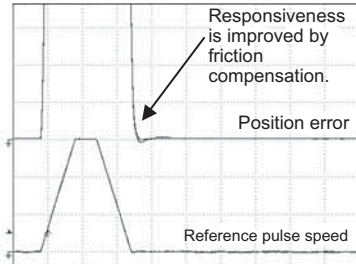
Step	Operation
1	<p>Set the following parameters for friction compensation to the factory setting as follows. Friction compensation gain (Pn121): 100 Friction compensation coefficient (Pn123): 0 Friction compensation frequency correction (Pn124): 0 Friction compensation gain correction (Pn125): 100</p> <p>Note: Always use the factory-set values for friction compensation frequency correction (Pn124) and friction compensation gain correction (Pn125).</p>
2	<p>To check the effect of friction compensation, increase the friction compensation coefficient (Pn123).</p> <p>Note: Normally, set the upper limit of the friction compensation coefficient (Pn123) to 95% max.</p>
3	<p>If the friction compensation is insufficient in step 2, increase the set value in Pn121 to where the equipment does not vibrate.</p> <p>Note: The SERVOPACK may vibrate if Pn121 is set to a value the same as or higher than the resonance frequency of the equipment. If necessary, adjust Pn121 in increments of 10%.</p> <p><b>Effect of Adjustment</b> The following graph shows the responsiveness with and without proper adjustment.</p> <div style="display: flex; justify-content: space-around; align-items: flex-start;"> <div style="text-align: center;">  <p>Without friction compensation</p> </div> <div style="text-align: center;">  <p>With friction compensation</p> </div> </div> <p><b>Effect of Adjustment Parameters</b></p> <p><b>Pn121: Friction Compensation Gain</b> This parameter sets the responsiveness for external disturbance. The higher the set value is, the better the responsiveness will be. If the equipment has a resonance frequency, however, vibration may result if the set value is the same as or high than the resonance frequency.</p> <p><b>Pn123: Friction Compensation Coefficient</b> This parameter sets the effect of friction compensation. The higher the set value is, the more effective friction compensation will be. If the set value is excessively high, however, the vibration will occur easily. Usually, set the value to 95% or less.</p>

### 5.8.3 Current Control Mode Selection

This function reduces high-frequency noises while the linear servomotor is being stopped. This function is enabled by default and set to be effective under different application conditions.

Input Voltage	Applicable SERVOPACK Model SGD V-
200 V	120A□□A, 180A□□A, 200A□□A, 330A□□A, 550A□□A
400 V	3R5D□□A, 5R4D□□A, 8R4D□□A, 120D□□A, 170D□□A, 260D□□A

Parameter	Meaning	When Enabled	Classification
Pn009	n. □□0□	After restart	Tuning
	n. □□1□		



IMPORTANT

- When this function is executed, the load ratio may increase while the linear servomotor is being stopped.

### 5.8.4 Current Gain Level Setting

This function reduces noises by adjusting the parameter value for current control inside the SERVOPACK according to the speed loop gain (Pn100). The noise level can be reduced by reducing the current gain level (Pn13D) from its factory setting of 2000% (disabled). If the set value of Pn13D is decreased, the level of noise will be lowered, but the response characteristics of the SERVOPACK will also be degraded. Adjust the current gain level within the allowable range at which SERVOPACK response characteristics can be secured.

Pn13D	Current Gain Level				Classification
			Speed	Position	
	Setting Range	Setting Unit	Factory Setting	When Enabled	
	100 to 2000	1 %	2000	Immediately	Tuning



IMPORTANT

- If the parameter setting of the current gain level is changed, the responsiveness characteristic of the speed loop will also change. The servo must, therefore, be readjusted again.

### 5.8.5 Speed Detection Method Selection

This function can ensure smooth movement of the linear servomotor while the linear servomotor is running. This function is disabled by default. Set the value of Pn009.2 = 1 to enable this function. When the linear scale pitch is long, noise produced while the linear servomotor is running can be reduced by using this function.

Parameter	Meaning	When Enabled	Classification
Pn009	n. □0□□	After restart	Tuning
	n. □1□□		



IMPORTANT

- If this function is changed, the responsiveness characteristic of the speed loop will also change. The servo must, therefore, be readjusted again.

## 5.9 Compatible Adjustment Function

The  $\Sigma$ -V series SERVOPACKs have the adjustment functions explained in sections 5.1 to 5.8 that can be used to make machine adjustments. This section explains compatible functions provided by earlier models, such as the  $\Sigma$ -III SERVOPACK.

### 5.9.1 Feedforward Reference

Applies feedforward control compensation in position control inside the SERVOPACK. Use this parameter to shorten positioning time.

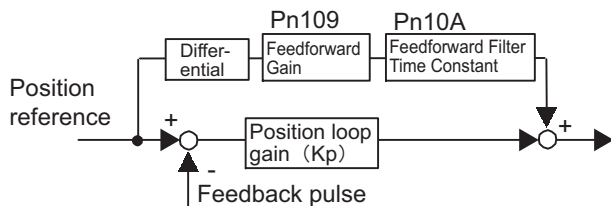

<b>Pn109</b>	Feedforward Gain <span style="float: right;">Position</span>				Classification
	Setting Range	Setting Unit	Factory Setting	When Enabled	
	0 to 100	1%	0	Immediately	Tuning
<b>Pn10A</b>	Feedforward Filter Time Constant <span style="float: right;">Position</span>				Classification
	Setting Range	Setting Unit	Factory Setting	When Enabled	
	0 to 6400	0.01 ms	0	Immediately	Tuning

If the Feedforward Gain (Pn109) is set to a value that is too high, the machine may vibrate. The gain setting should be set to a value less than 80%.

### 5.9.2 Using the Mode Switch (P/PI Switching)

Use the mode switch (P/PI switching\*) function in the following cases:

- To suppress overshooting during acceleration or deceleration (for speed control)
- To suppress overshooting during positioning and reduce the settling time (for position control)

\* P Control: Proportional control  
 PI Control: Proportional/integral control

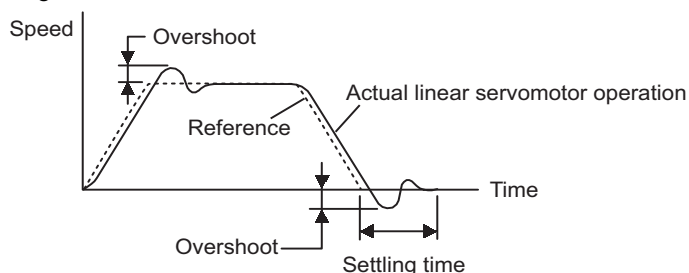

To enable the mode switch, set Pn10B.0 to 0 to 3. The mode switch changes the speed-control mode to PI (proportional/integral) control or P (proportional) control.

Notes:

- Monitoring the speed response waveform and position error waveform is required for adjustment.
- If I-P control is selected for speed loop control, the mode switching function will be disabled.

### (1) Related Parameters

Select the conditions to switch modes (P or PI control switching) by using the following parameters.

Parameter	Mode Switch Selection	Parameter Containing Detection Point Setting	When Enabled	Classification
<b>Pn10B</b>	n.□□□0	Uses a force reference level for detection point. [Factory setting]	Pn10C	Immediately Setup
	n.□□□1	Uses a speed reference level for detection point.	Pn181	
	n.□□□2	Uses an acceleration level for detection point.	Pn182	
	n.□□□3	Uses an position error pulse level for detection point.	Pn10F	
	n.□□□4	Does not use mode switch function.	–	

#### ■ Parameters to set the detection point

<b>Pn10C</b>	Mode Switch (Force Reference) <span style="float:right">Speed <input type="checkbox"/> Position <input type="checkbox"/></span>				Classification
	Setting Range	Setting Unit	Factory Setting	When Enabled	
	0 to 800	1%	200	Immediately	Tuning
<b>Pn181</b>	Mode Switch (Speed Reference) <span style="float:right">Speed <input type="checkbox"/> Position <input type="checkbox"/></span>				Classification
	Setting Range	Setting Unit	Factory Setting	When Enabled	
	0 to 10000	1 mm/s	0	Immediately	Tuning
<b>Pn182</b>	Mode Switch (Acceleration) <span style="float:right">Speed <input type="checkbox"/> Position <input type="checkbox"/></span>				Classification
	Setting Range	Setting Unit	Factory Setting	When Enabled	
	0 to 30000	1 mm/s <sup>2</sup>	0	Immediately	Tuning
<b>Pn10F</b>	Mode Switch (Position Error Pulse) <span style="float:right">Position <input type="checkbox"/></span>				Classification
	Setting Range	Setting Unit	Factory Setting	When Enabled	
	0 to 10000	1 reference unit	0	Immediately	Tuning

Mode switch functions according to the detection point are as follows.

#### ■ Using the Force Reference Level to Switch Modes (Factory Setting)

With this setting, the speed loop is switched to P control when the value of force reference input exceeds the force set in Pn10C.

The factory setting for the force reference detection point is 200% of the rated force.

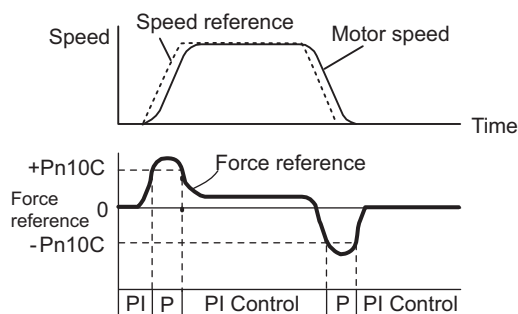

<Example>

If the mode switch function is not being used and the SERVOPACK is always operated with PI control, the speed of the linear servomotor may overshoot due to force saturation during acceleration or deceleration. The mode switch function suppresses force saturation and eliminates the overshooting of the motor speed.

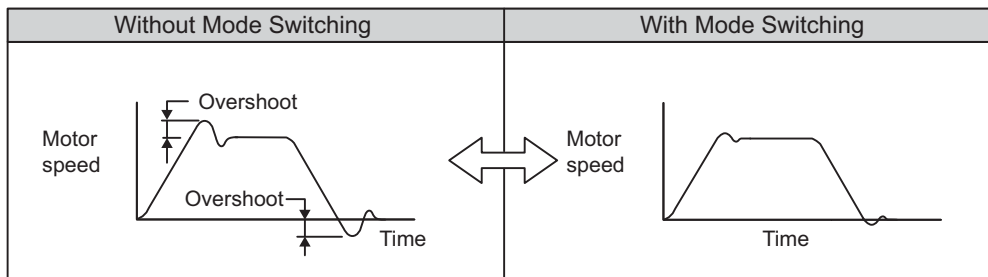

■ Using the Speed Reference Level to Switch Modes

With this setting, the speed loop is switched to P control when the value of speed reference input exceeds the speed set in Pn181.

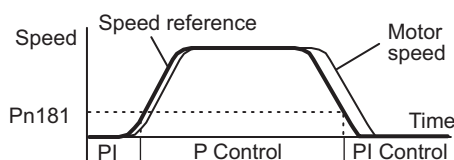

<Example>

In this example, the mode switch is used to reduce the settling time. It is necessary to increase the speed loop gain to reduce the settling time. Using the mode switch suppresses overshooting when speed loop gain is increased.

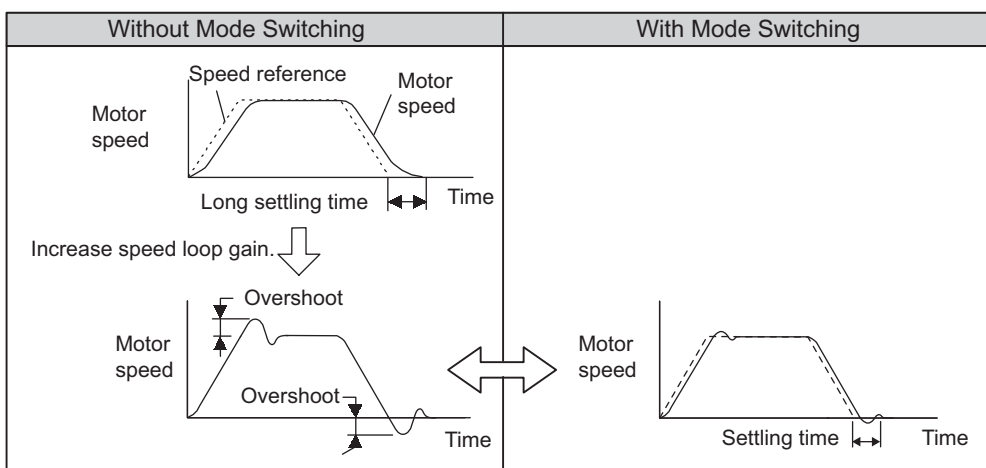



### ■ Using the Acceleration Level to Switch Modes

With this setting, the speed loop is switched to P control when the speed reference exceeds the acceleration rate set in Pn182.

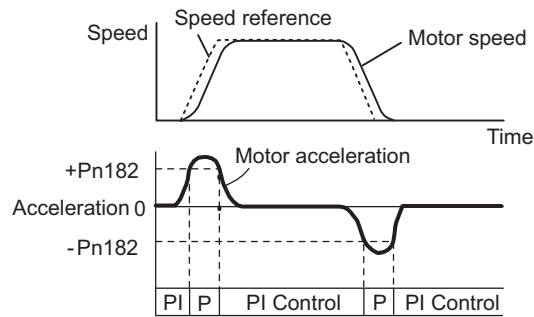

#### <Example>

If the mode switch function is not being used and the SERVOPACK is always operated with PI control, the speed of the linear servomotor may overshoot due to force saturation during acceleration or deceleration. The mode switch function suppresses force saturation and eliminates the overshooting of the linear servomotor speed.

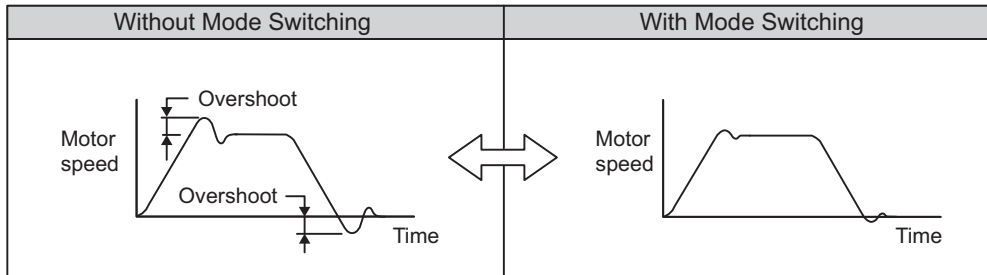

■ Using the Position Error Pulse Level to Switch Modes

With this setting, the speed loop is switched to P control when the position error pulse exceeds the value set in Pn10F.

This setting is effective with position control only.

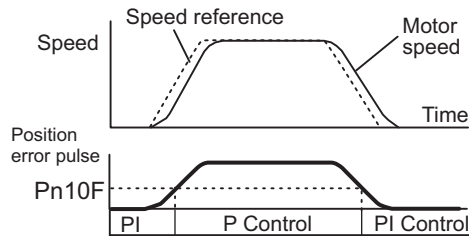

<Example>

In this example, the mode switch is used to reduce the settling time. It is necessary to increase the speed loop gain to reduce the settling time. Using the mode switch suppresses overshooting when speed loop gain is increased.

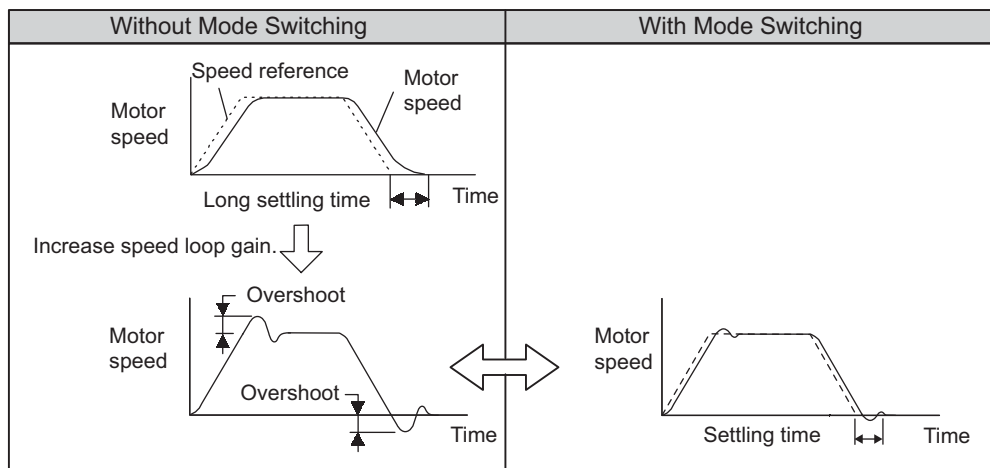

### 5.9.3 Force Reference Filter

As shown in the following diagram, the force reference filter contains first order lag filter and notch filters arrayed in series, and each filter operates independently. The notch filters can be enabled and disabled with the Pn408.

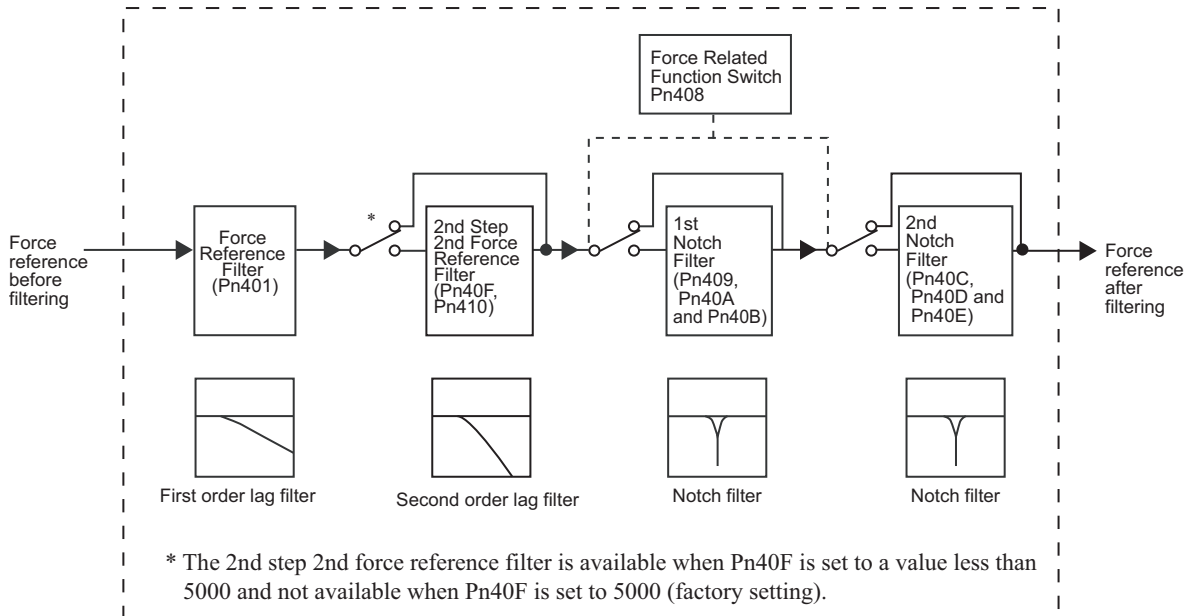

#### (1) Force Reference Filter

If you suspect that machine vibration is being caused by the servo drive, try adjusting the force reference filter time constants. This may stop the vibration. The lower the value, the better the speed control response will be, but there is a lower limit that depends on the machine conditions.

<b>Pn401</b>	Force Reference Filter Time Constant <span style="float:right">Speed Position Force</span>				Classification
	Setting Range	Setting Unit	Factory Setting	When Enabled	
	0 to 65535	0.01 ms	100	Immediately	Tuning

#### ■ Force Reference Filter Guide

Use the speed loop gain (Pn100 [Hz]) and the force reference filter time constant (Pn401 [ms]).

Adjusted value for stable control:  $Pn401 [ms] \leq 1000 / (2\pi \times Pn100 [Hz] \times 4)$

Critical gains:  $Pn401 [ms] < 1000 / (2\pi \times Pn100 [Hz] \times 1)$

<b>Pn40F</b>	2nd Step 2nd Force Reference Filter Frequency <span style="float:right">Speed Position Force</span>				Classification
	Setting Range	Setting Unit	Factory Setting	When Enabled	
	100 to 5000	1 Hz	5000*	Immediately	Tuning
<b>Pn410</b>	2nd Step 2nd Force Reference Filter Q Value <span style="float:right">Speed Position Force</span>				Classification
	Setting Range	Setting Unit	Factory Setting	When Enabled	
	50 to 1000	0.01	50	Immediately	Tuning

\* Setting the Pn40F to 5000 disables the force reference filter.

## (2) Notch Filter

The notch filter can eliminate specific frequency vibration generated by sources such as resonances of ball screw axes.

The notch filter puts a notch in the gain curve at the specific vibration frequency. The frequency components near the notch frequency can be eliminated with this characteristic.

A higher notch filter Q value produces a sharper notch and phase delay.

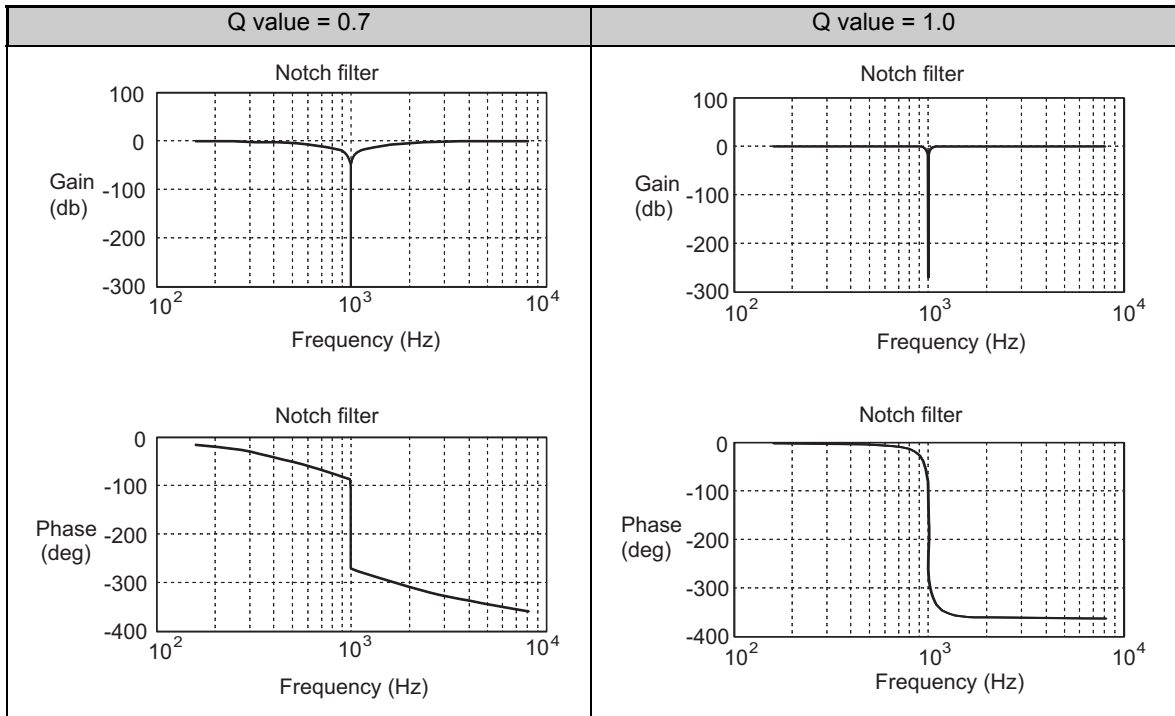

Set the notch filter enabled/disabled with Pn408.

Parameter	Function	When Enabled	Classification
<b>Pn408</b>	n.□□□0	Immediately	Setup
	n.□□□1		
	n.□0□□		
	n.□1□□		

Set the machine's vibration frequency in the parameter of a notch filter that is being used.

Pn409	1st Notch Filter Frequency <span style="float:right">Speed   Position   Force</span>				Classification
	Setting Range	Setting Unit	Factory Setting	When Enabled	
	50 to 5000	1 Hz	5000	Immediately	Tuning
Pn40A	1st Notch Filter Q Value <span style="float:right">Speed   Position   Force</span>				Classification
	Setting Range	Setting Unit	Factory Setting	When Enabled	
	50 to 1000	0.01	70	Immediately	Tuning
Pn40B	1st Notch Filter Depth <span style="float:right">Speed   Position   Force</span>				Classification
	Setting Range	Setting Unit	Factory Setting	When Enabled	
	0 to 1000	0.001	0	Immediately	Tuning
Pn40C	2nd Notch Filter Frequency <span style="float:right">Speed   Position   Force</span>				Classification
	Setting Range	Setting Unit	Factory Setting	When Enabled	
	50 to 5000	1 Hz	5000	Immediately	Tuning
Pn40D	2nd Notch Filter Q Value <span style="float:right">Speed   Position   Force</span>				Classification
	Setting Range	Setting Unit	Factory Setting	When Enabled	
	50 to 1000	0.01	70	Immediately	Tuning
Pn40E	2nd Notch Filter Depth <span style="float:right">Speed   Position   Force</span>				Classification
	Setting Range	Setting Unit	Factory Setting	When Enabled	
	0 to 1000	0.001	0	Immediately	Tuning



**IMPORTANT**

- Sufficient precautions must be taken when setting the notch filter frequencies. Do not set the notch filter frequencies (Pn409 or Pn40C) that is close to the speed loop's response frequency. Set the frequencies at least four times higher than the speed loop's response frequency. (The Pn103 must be set correctly.) Setting the notch filter frequency too close to the response frequency may cause vibration and damage the machine.
- Change the notch filter frequency (Pn409 or Pn40C) only when the linear servomotor is stopped. Vibration may occur if the notch filter frequency is changed when the linear servomotor is running.

### 5.9.4 Position Integral Time Constant

This function adds an integral control operation to the position loop. It is effective for electronic cam or electronic shaft applications.

Pn11F	Position Integral Time Constant <span style="float:right">Position</span>				Classification
	Setting Range	Setting Unit	Factory Setting	When Enabled	
	0 to 50000	0.1 ms	0	Immediately	Tuning

## Utility Functions (Fn□□□)

6.1 List of Utility Functions	6-2
6.2 Alarm History Display (Fn000)	6-3
6.3 JOG Operation (Fn002)	6-4
6.4 Origin Search (Fn003)	6-6
6.5 Program JOG Operation (Fn004)	6-8
6.6 Initializing Parameter Settings (Fn005)	6-14
6.7 Clearing Alarm History (Fn006)	6-15
6.8 Offset Adjustment of Analog Monitor Output (Fn00C)	6-16
6.9 Gain Adjustment of Analog Monitor Output (Fn00D)	6-18
6.10 Automatic Offset-Signal Adjustment of the Motor Current Detection (Fn00E)	6-20
6.11 Manual Offset-Signal Adjustment of the Motor Current Detection (Fn00F)	6-21
6.12 Write Prohibited Setting (Fn010)	6-22
6.13 Servomotor Model Display (Fn011)	6-24
6.14 Software Version Display (Fn012)	6-25
6.15 Resetting Configuration Error of Option Module (Fn014)	6-26
6.16 Vibration Detection Level Initialization (Fn01B)	6-27
6.17 Display of SERVOPACK and Servomotor ID (Fn01E)	6-29
6.18 Software Reset (Fn030)	6-30
6.19 EasyFFT (Fn206)	6-31
6.20 Online Vibration Monitor (Fn207)	6-36

## 6.1 List of Utility Functions

Utility functions are used to execute the functions related to linear servomotor operation and adjustment. Each utility function has a number starting with Fn.

The following table lists the utility functions and reference section.

Function No.	Function	Reference Section
Fn000	Alarm history display	6.2
Fn002	JOG operation	6.3
Fn003	Origin search	6.4
Fn004	Program JOG operation	6.5
Fn005	Initializing parameter settings	6.6
Fn006	Clearing alarm history	6.7
Fn00C	Offset adjustment of analog monitor output	6.8
Fn00D	Gain adjustment of analog monitor output	6.9
Fn00E	Automatic offset-signal adjustment of motor current detection signal	6.10
Fn00F	Manual offset-signal adjustment of motor current detection signal	6.11
Fn010	Write prohibited setting	6.12
Fn011	Servomotor model display	6.13
Fn012	Software version display	6.14
Fn014	Resetting configuration error of option module	6.15
Fn01B	Vibration detection level initialization	6.16
Fn01E	Display of SERVOPACK and servomotor ID	6.17
Fn020	Origin setting*	4.5.3
Fn030	Software reset	6.18
Fn080	Polarity detection*	4.5.2
Fn200	Tuning-less level setting	5.2.2
Fn201	Advanced autotuning	5.3.2
Fn202	Advanced autotuning by reference	5.4.2
Fn203	One-parameter tuning	5.5.2
Fn204	Anti-resonance control adjustment function	5.6.2
Fn205	Vibration suppression function	5.7.2
Fn206	EasyFFT	6.19
Fn207	Online vibration monitor	6.20

\* For details, refer to *Σ-V Series User's Manual Setup Linear Motor* (SIEP S800000 44).

Note 1. If the write prohibited setting (Fn010) is enabled, "NO-OP" is displayed on the status display of the digital operator if the user attempts to execute the above utility functions. To execute these utility functions, set Fn010 to write permitted. For details, refer to *6.12 Write Prohibited Setting (Fn010)*.

2. If the utility functions given above are executed using SigmaWin+ or the option module, "NO-OP" will be displayed if an attempt is made to execute the utility function using the digital operator.

## 6.2 Alarm History Display (Fn000)

This function displays the alarm history to check the ten latest alarms.

The latest ten alarm numbers and time stamps\* can be checked.

\* Time Stamps

A function that measures the ON times of the control power supply and main circuit power supply in 100-ms units and displays the operating time when an alarm occurs. The time stamp operates around the clock for approximately 13 years.

<Example of Time Stamps>













If 36000 is displayed,

360000 [ms] = 3600 [s]

= 60 [min]

= 1 [h] Therefore, the total number of operating hours is 1.

Follow the steps below to confirm the alarm histories.

Step	Display Example	Keys	Operation
1	<pre> BB      -FUNCTION- Fn207: V-Monitor Fn000: Alm History Fn002: JOG Fn003: Z-Search           </pre>	  	Press the  Key to open the Utility Function Mode main menu and select Fn000.
2	<pre> 0: D00  00001207196 1: 720  00000032651 2: 511  00000009043 3: ----           </pre> <p>Alarm History No. "0" is the latest, "9" is the oldest.</p> <p>Alarm No.      Time stamps</p>		Press the  Key. Then, the alarm history will appear.
3	<pre> A.D00  -ALARM- 0: D00  00001207196 1: 720  00000032651 2: 511  00000009043 3: ----           </pre> <pre> A.D00  -ALARM- 1: 720  00000032651 2: 511  00000009043 3: ---- 4: ----           </pre> <pre> A.D00  -ALARM- 2: 511  00000009043 3: ---- 4: ---- 5: ----           </pre>	 	Press the  or  Key to scroll through the alarm history.
4	<pre> BB      -FUNCTION- Fn207: V-Monitor Fn000: Alm History Fn002: JOG Fn003: Z-Search           </pre>		Press the  Key to return to the Utility Function Mode main menu.

<Notes>

- If the same alarm occurs again more than one hour later, a record of this alarm is also saved.
- The message "□: \_\_\_" indicates that no alarm occurs.
- Delete the alarm history using the parameter Fn006. The alarm history is not cleared on alarm reset or when the SERVOPACK power is turned OFF.



## 6.3 JOG Operation (Fn002)

JOG operation is used to check the operation of the linear servomotor under speed control without connecting the SERVOPACK to the host controller.

### CAUTION

While the SERVOPACK is in JOG operation, the overtravel function will be disabled. Consider the operating range of the machine when performing JOG operation for the SERVOPACK.

#### (1) Settings before Operation























The following settings are required before performing JOG operation.









- If a servo ON command is input, send a servo OFF command.
- Considering the operating range of the machine, set the JOG operation speed in Pn383.

Pn383	JOG Speed				Classification
	Setting Range	Setting Unit	Factory Setting	When Enabled	
	0 to 10000	1 mm/s	500	Immediately	

#### (2) Operating Procedure

Follow the steps below to set the JOG speed. The following example is given when the movement direction of linear servomotor is set as Pn000.0 = 0 (linear scale counting up direction is regarded as the forward run).

Step	Display Example	Keys	Operation
1	<pre> BB      -FUNCTION- Fn000: Alm History Fn002: JOG Fn003: Z-Search Fn004: Program JOG           </pre>	  	<p>Press the  Key to view the main menu for the utility function mode.</p> <p>Use the  or  Key to move through the list, select Fn002.</p>
2	<pre> BB      -JOG- Pn383=00500 Un000= 00000 Un002= 00000 Un00D=00000000           </pre>		<p>Press the  Key. The display is switched to the execution display of Fn002.</p> <p>Note: If the display is not switched and “NO-OP” is displayed in the status display, change the following settings. (Refer to 6.12.)</p> <ul style="list-style-type: none"> <li>• If Write Prohibited is set in Fn010: → Cancel the Write Prohibited setting.</li> <li>• If a servo ON command is input: → Send a servo OFF command.</li> </ul>
3	<pre> BB      -JOG- Pn383=0050<u>0</u> Un000= 00000 Un002= 00000 Un00D=00000000           </pre>		<p>Press the  Key.</p> <p>The cursor moves to the setting side (the right side) of Pn383 (JOG speed).</p>
4	<pre> BB      -JOG- Pn383=01<u>0</u>00 Un000= 00000 Un002= 00000 Un00D=00000000           </pre>	   	<p>Press the  or  Key and the  or  Key to set the JOG speed to 1000 (mm/s).</p>
5	<pre> BB      -JOG- Pn383=01000 Un000= 00000 Un002= 00000 Un00D=00000000           </pre>		<p>Press the  Key.</p> <p>The setting value is entered, and the cursor moves to the parameter number side (the left side).</p>
6	<pre> RUN     -JOG- Pn383=01000 Un000= 00000 Un002= 00000 Un00D=00000000           </pre>		<p>Press the  Key.</p> <p>“RUN” is displayed in the status display, and power is applied to the linear servomotor.</p>

Step	Display Example	Keys	Operation
7	<pre> RUN                -JOG- Pn383=01000 Un000= 00000 Un002= 00000 Un00D=00000000 </pre>		<p>The linear servomotor will move at the present speed set in Pn383 while the  Key (in forward direction) or  Key (in reverse direction) is pressed.</p> <p>  Forward   Reverse </p>
8	<pre> BB                -JOG- Pn383=01000 Un000= 00000 Un002= 00000 Un00D=00000000 </pre>		<p>After having confirmed the correct motion of linear servomotor, press the  Key. “BB” is displayed in the status display, and power is not applied to the linear servomotor.</p>
9	<pre> BB                -FUNCTION- Fn000: Alm History Fn002: JOG Fn003: Z-Search Fn004: Program JOG </pre>		<p>Press the  Key to return to the Utility Function Mode main menu.</p>
10	After JOG operation, turn OFF the SERVOPACK power supply and then turn ON again.		

## 6.4 Origin Search (Fn003)

The origin search is designed to position the origin pulse position of the linear scale (phase C) and to clamp at the position.

### CAUTION

- The forward run prohibited (P-OT) and reverse run prohibited (N-OT) signals are not effective in origin search mode.

This mode is used when the motor shaft needs to be aligned to the machine. Motor speed at the time of execution: 15 mm/s.



















### (1) Settings before Operation



The following settings are required before performing an origin search.

- If a servo ON command is input, send a servo OFF command.

### (2) Operating Procedure

Follow the steps below to execute the origin search.

Step	Display Example	Keys	Operation
1	<pre> BB      —FUNCTION— Fn002 : JOG Fn003 : Z-Search Fn004 : Program JOG Fn005 : Prm Init           </pre>	  	<p>Press the  Key to view the main menu for the utility function mode.</p> <p>Use the  or  Key to move through the list, select Fn003.</p>
2	<pre> BB      —Z-Search— Un000 = 00000 Un002 = 00000 Un003 = 00774 Un00D = 00000000           </pre>		<p>Press the  Key. The display is switched to the execution display of Fn003.</p> <p>Note: If the display is not switched and “NO-OP” is displayed in the status display, change the following settings. (Refer to 6.12.)</p> <ul style="list-style-type: none"> <li>• If Write Prohibited is set in Fn010: → Cancel the Write Prohibited setting.</li> <li>• If a servo ON command is input: → Send a servo OFF command.</li> </ul>
3	<pre> BB      —Z-Search— Un000 = 00000 Un002 = 00000 Un003 = 00774 Un00D = 00000000           </pre>		<p>Press the  Key.</p> <p>“RUN” is displayed in the status display, and power is applied to the linear servomotor.</p> <p>Note: If the linear servomotor is already at the zero position, “-Complete-” is displayed.</p>
4	<pre> RUN      —Complete— Un000 = 00000 Un002 = 00000 Un003 = 00000 Un00D = 00001D58           </pre>	 	<p>When the parameter is set to Pn000.0 = 0 (factory setting), pressing the  Key will run the linear servomotor in the forward direction.</p> <p>Pressing the  Key will run the linear servomotor in the reverse direction. When the parameter is set to Pn000.0 = 1, the movement direction of the linear servomotor is reversed.</p> <p>Press the  or  Key until the linear servomotor stops. If the origin search completed normally, “-Complete-” is displayed on the right top on the screen.</p>
5	<pre> BB      —Z-Search— Un000 = 00000 Un002 = 00000 Un003 = 00774 Un00D = 00001D58           </pre>		<p>When the origin search is completed, press the  Key.</p> <p>“BB” is displayed in the status display, and power will not be applied to the linear servomotor. The display “-Complete-” changes to “-Z-Search.”</p>

Step	Display Example	Keys	Operation
6	<pre> BB      —FUNCTION— Fn002: JOG Fn003: Z-Search Fn004: Program JOG Fn005: Prm Init </pre>		Press the  Key to return to the Utility Function Mode main menu.
7	After origin search operation, turn OFF the SERVOPACK power supply and then turn ON again.		

## 6.5 Program JOG Operation (Fn004)

The Program JOG Operation is a utility function, that allows continuous automatic operation determined by the preset operation pattern, movement distance, movement speed, acceleration/deceleration time, waiting time, and number of times of movement.

This function can be used to move the linear servomotor without it having to be connected to a host controller for the machine as a trial operation in JOG operation mode. Program JOG Operation can be used to confirm the operation and for simple positioning operations.

### (1) Settings before Operation

The following settings are required before performing a program JOG operation.

- Consider the machine operation range and safe operation speed when setting the movement distance and movement speed correctly.
- If a servo ON command has been input, send a servo OFF command.
- The main power is supplied.
- No alarm is detected.
- The overtravel does not occur.
- HWBB function is disable.

Note:

- The functions that are applicable for position control, such as position reference filter, can be used.
- The overtravel function is enabled in this function.

### (2) Related Parameters

<b>Pn530</b>	Program JOG Operation Related Switch <span style="float:right">Speed Position Force</span>				Classification
	Setting Range	Setting Unit	Factory Setting	When Enabled	
	0000 to 0005	–	0000	Immediately	Setup
<b>Pn531</b>	Program JOG Movement Distance <span style="float:right">Speed Position Force</span>				Classification
	Setting Range	Setting Unit	Factory Setting	When Enabled	
	1 to 1073741824(2 <sup>30</sup> )	1 reference unit	32768	Immediately	Setup
<b>Pn585</b>	Program JOG Movement Speed <span style="float:right">Speed Position Force</span>				Classification
	Setting Range	Setting Unit	Factory Setting	When Enabled	
	1 to 10000	1 mm/s	500	Immediately	Setup
<b>Pn534</b>	Program JOG Acceleration/Deceleration Time <span style="float:right">Speed Position Force</span>				Classification
	Setting Range	Setting Unit	Factory Setting	When Enabled	
	2 to 10000	1 ms	100	Immediately	Setup
<b>Pn535</b>	Program JOG Waiting Time <span style="float:right">Speed Position Force</span>				Classification
	Setting Range	Setting Unit	Factory Setting	When Enabled	
	0 to 10000	1 ms	100	Immediately	Setup
<b>Pn536</b>	Number of Times of Program JOG Movement <span style="float:right">Speed Position Force</span>				Classification
	Setting Range	Setting Unit	Factory Setting	When Enabled	
	0 to 1000	1 time	1	Immediately	Setup

Parameter	Contents	Factory Setting	
Pn530	n.□□□0	(Waiting time Pn535 → Forward movement Pn531) × Number of times of movement Pn536	0
	n.□□□1	(Waiting time Pn535 → Reverse movement Pn531) × Number of times of movement Pn536	
	n.□□□2	(Waiting time Pn535 → Forward movement Pn531) × Number of times of movement Pn536 (Waiting time Pn535 → Reverse movement Pn531) × Number of times of movement Pn536	
	n.□□□3	(Waiting time Pn535 → Reverse movement Pn531) × Number of times of movement Pn536 (Waiting time Pn535 → Forward movement Pn531) × Number of times of movement Pn536	
	n.□□□4	(Waiting time Pn535 → Forward movement Pn531 → Waiting time Pn535 → Reverse movement Pn531) × Number of times of movement Pn536	
	n.□□□5	(Waiting time Pn535 → Reverse movement Pn531 → Waiting time Pn535 → Forward movement Pn531) × Number of times of movement Pn536	

Note: For details of Pn530, refer to (3) Setting Infinite Time Operation and (4) Program JOG Operation Patterns.

### (3) Setting Infinite Time Operation

- When 0, 1, 4 or 5 is set to Pn530.0, setting 0 to Pn536 (Number of Times of Program JOG Movement) enables infinite time operation.
- Program JOG operation pattern follows the setting of Pn530.0. Only number of times of program JOG movement is infinite. For details, refer to (4) Program JOG Operation Patterns.
- To stop infinite time operation, press the JOG/SVON Key to turn the linear servomotor power OFF.

Note: 2 or 3 is set to Pn530.0, infinite time operation is disabled.  
0 or 1 is set to Pn530.0, movement is one direction. Take note of movable range.

### (4) Program JOG Operation Patterns

The following example is given when the movement direction of the linear servomotor is set as Pn000.0 = 0 (Linear scale counting up direction as forward direction).

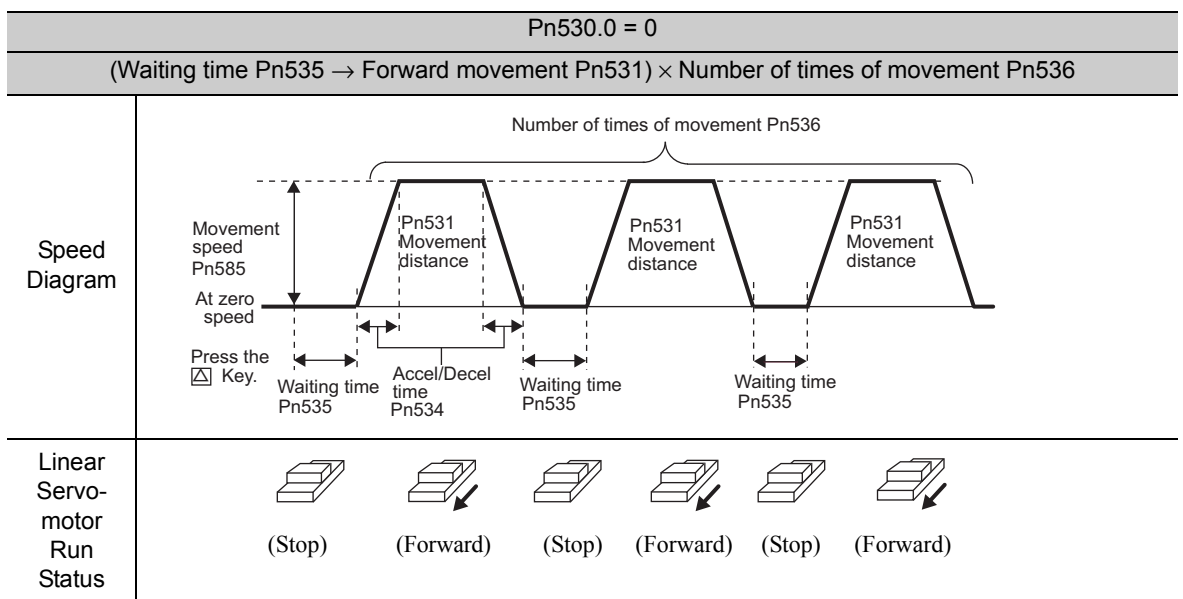

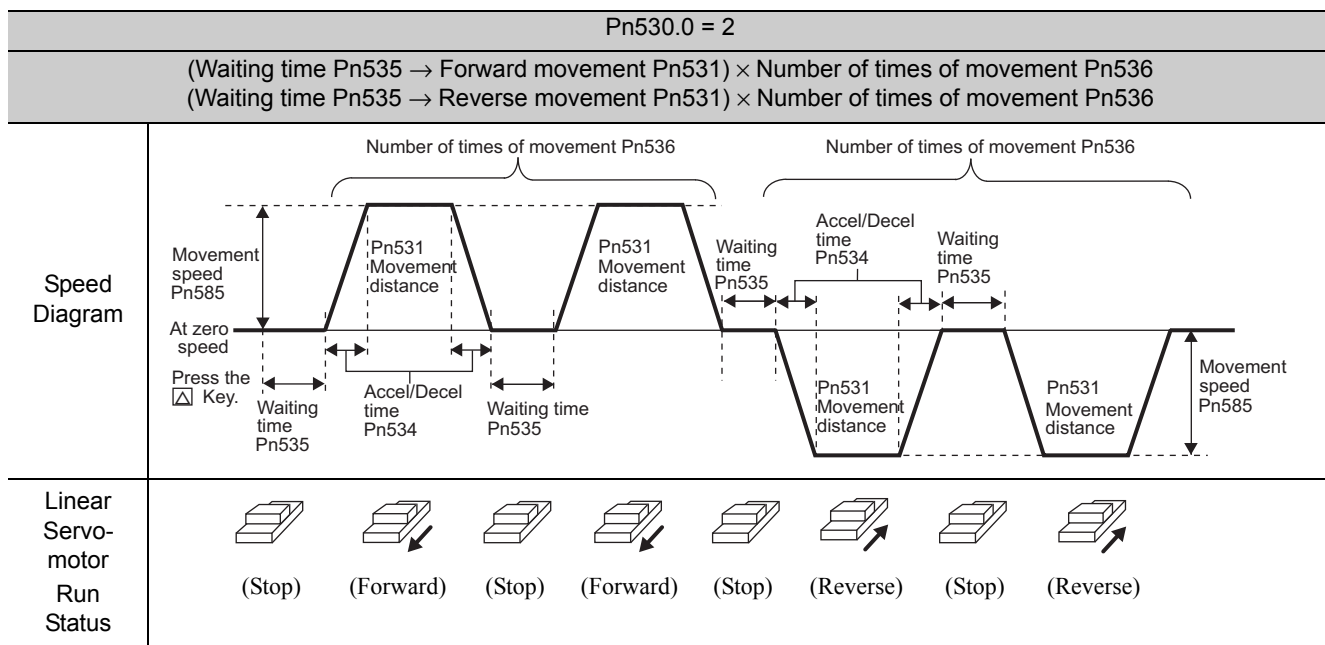
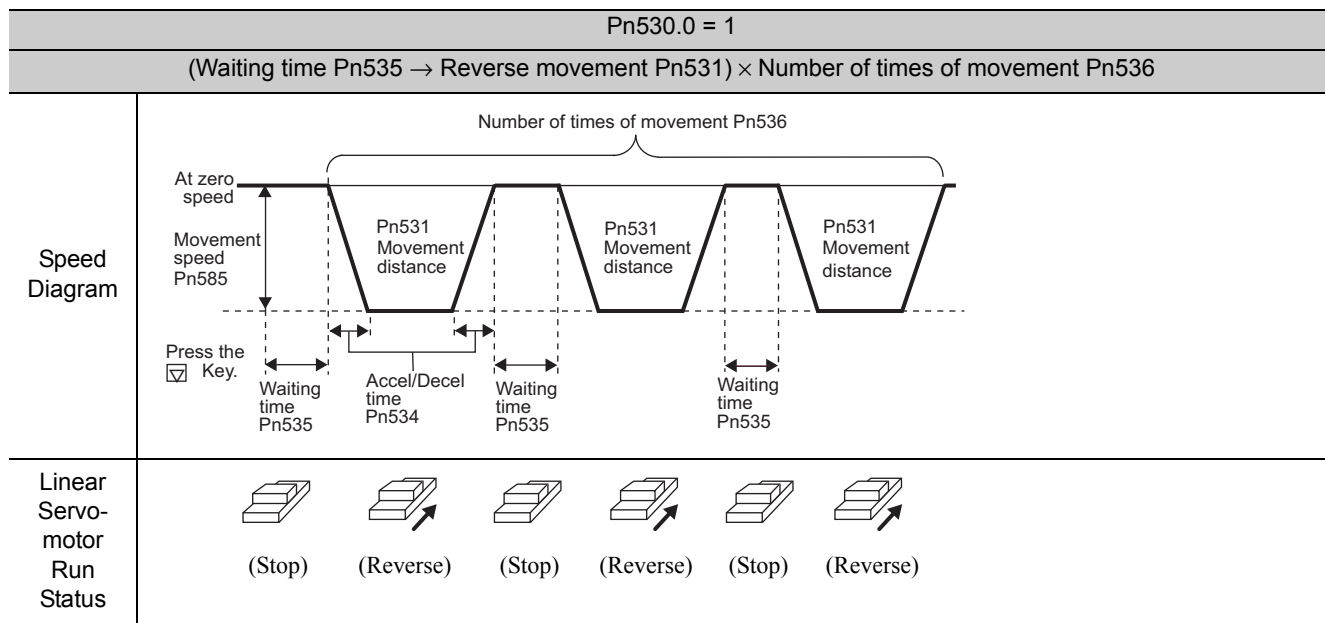

Note: When 2 is set to Pn530.0, infinite time operation is disabled.

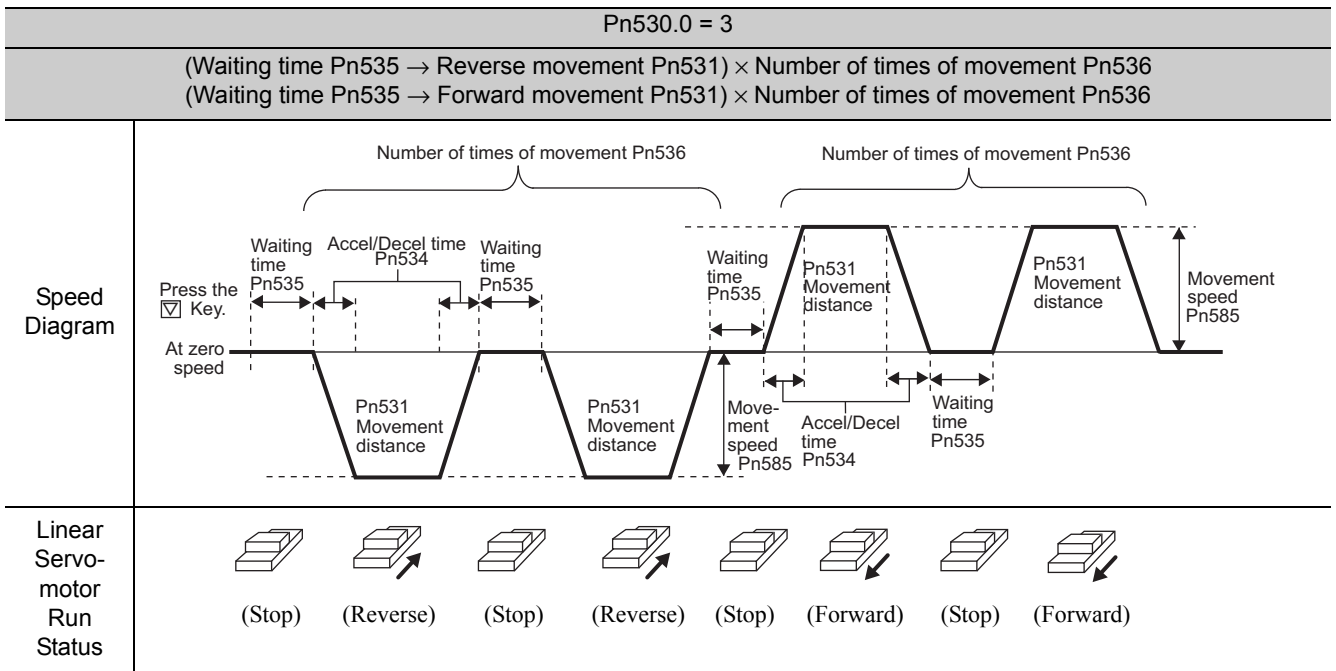

Note: When 3 is set to Pn530.0, infinite time operation is disabled.

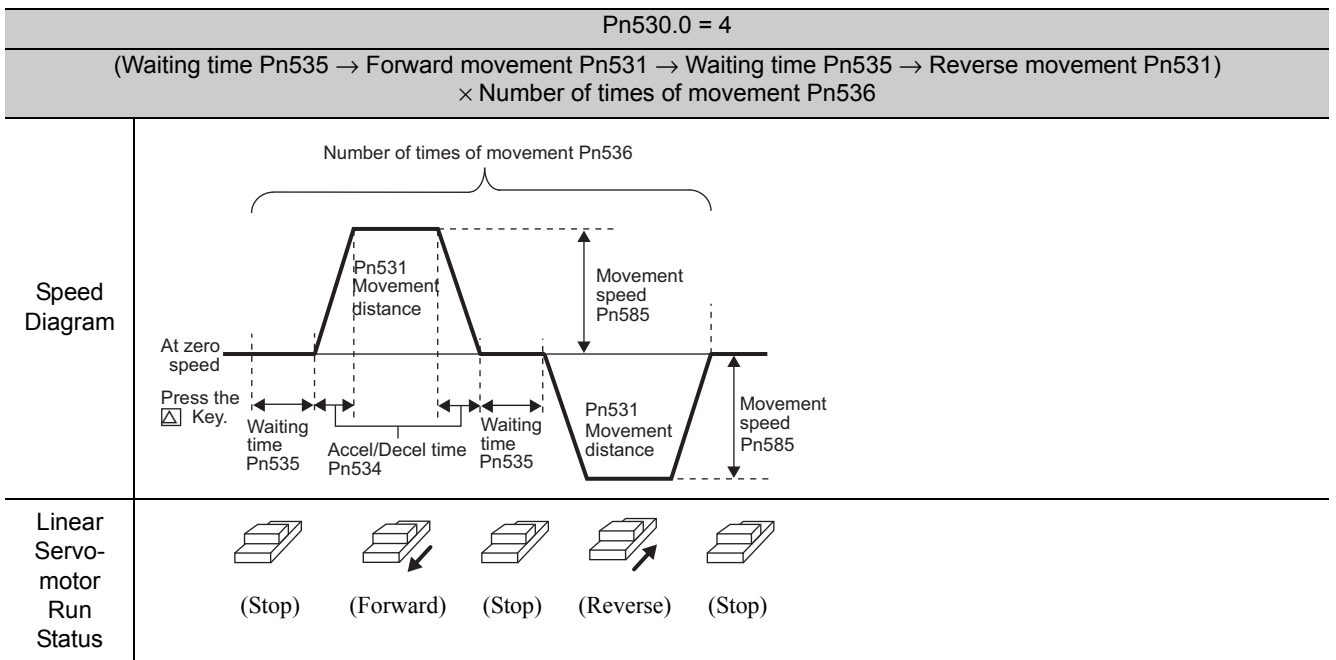



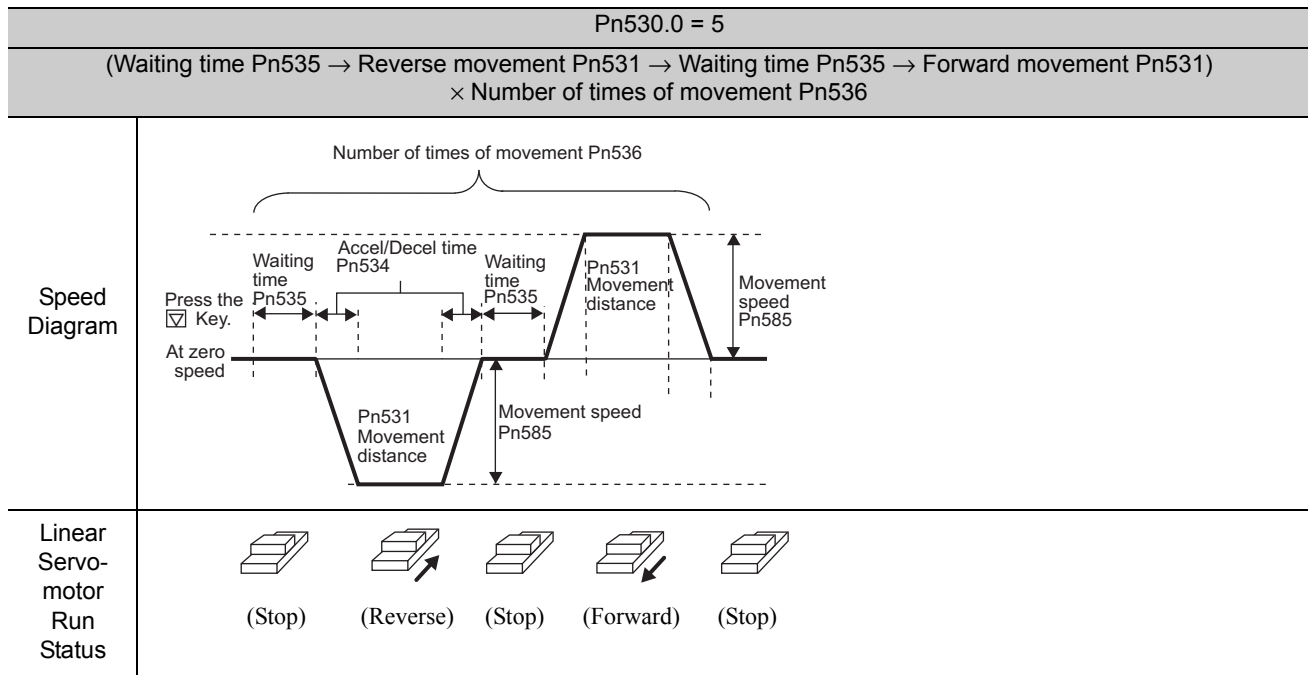



























## (5) Operating Procedure

Follow the steps below to perform the program JOG operation after setting a program for JOG operation.











Step	Display Example	Keys	Operation
1	<pre>BB      -FUNCTION- Fn003: Z-Search Fn004: Program JOG Fn005: Prm Init Fn006: AlmHist Clr</pre>	  	<p>Press the  Key to view the main menu for the utility function mode.</p> <p>Use the  or  Key to move through the list, select Fn004.</p>
2	<pre>BB      -PRG JOG- Pn531=00032768 Pn533=00500 Pn534=00100 Pn536=00001</pre>		<p>Press the  Key. The display is switched to the execution display of Fn004.</p> <p>Note: If the display is not switched and “NO-OP” is displayed in the status display, change the following settings. (Refer to 6.12.)</p> <ul style="list-style-type: none"> <li>• If Write Prohibited is set in Fn010: → Cancel the Write Prohibited setting.</li> <li>• If a servo ON command is input: → Send a servo OFF command.</li> </ul>
3	<pre>BB      -PRG JOG- Pn531=00032768 Pn533=00500 Pn534=00100 Pn536=00001</pre>		<p>Press the  Key to select a parameter to be set. In this example, Pn536 has been selected.</p>
4	<pre>BB      -PRG JOG- Pn531=00032768 Pn533=00500 Pn534=00100 Pn536=0000<u>1</u></pre>		<p>Press the  Key to move the cursor to the setting side (the right side) of Pn536.</p>
5	<pre>BB      -PRG JOG- Pn531=00032768 Pn533=00500 Pn534=00100 Pn536=000<u>10</u></pre>	 	<p>Press the  or  Key to change “1” to “10.”</p>
6	<pre>RUN     -PRG JOG- Pn531=00032768 Pn533=00500 Pn534=00100 Pn536=000<u>10</u></pre>		<p>Press the  Key to turn the linear servomotor power ON. The status of the display changes to “RUN”.</p>
		 	<p>Press the  (forward movement start) or  (reverse movement start) Key according to the first movement direction of the preset operation pattern for one second. The linear servomotor starts moving after the preset waiting time in Pn535.</p> <p>Note: Pressing the  Key again changes the status to “BB” (Servomotor power OFF) and stops movement even during operation.</p>
7	<pre>END     -PRG JOG- Pn531=00032768 Pn533=00500 Pn534=00100 Pn536=000<u>10</u></pre>		<p>When the set program JOG operation movement is completed, “END” will be displayed for one second, and then “RUN” will be displayed.</p> <p>Press the  Key. The linear servomotor enters BB status and the display returns to the Utility Function Mode main menu.</p>
8	After program JOG operation, turn OFF the SERVOPACK power supply and then turn ON again.		

## 6.6 Initializing Parameter Settings (Fn005)

This function is used when returning to the factory settings after changing parameter settings.

 <b>IMPORTANT</b>	<ul style="list-style-type: none"> <li>• Be sure to initialize the parameter settings while the linear servomotor power is OFF.</li> <li>• After initialization, turn OFF the SERVOPACK power supply and then turn ON again to validate the settings.</li> <li>• The parameters of the option module will not be initialized. For information on how to initialize the parameters of the option module, refer to the manual of the connected option module.</li> </ul>
---	--

Follow the steps below to initialize the parameter setting.











Step	Display Example	Keys	Operation
1	<pre>BB      -FUNCTION- Fn004: Program JOG Fn005: Prm Init Fn006: AlmHist Clr Fn008: Mturn Clr</pre>	  	<p>Press the  Key to view the main menu for the utility function mode.</p> <p>Use the  or  Key to move through the list, select Fn005.</p>
2	<pre>BB Parameter Init Start : [DATA] Return: [SET]</pre>		<p>Press the  Key. The display is switched to the execution display of Fn005.</p> <p>Note: If the display is not switched and “NO-OP” is displayed in the status display, change the following settings. (Refer to 6.12.)</p> <ul style="list-style-type: none"> <li>• If Write Prohibited is set in Fn010: → Cancel the Write Prohibited setting.</li> <li>• If a servo ON command is input: → Send a servo OFF command.</li> </ul>
3	<pre>BB Parameter Init Start : [DATA] Return: [SET]</pre>		<p>Press the  Key to initialize parameters. During initialization, “Parameter Init” is blinking in the display. After the initialization is completed, “Parameter Init” stops blinking and the status display changes as follows: “BB” to “DONE.”</p> <p>Note: Press the  Key not to initialize parameters. The display returns to the Utility Function Mode main menu.</p>
4	Turn OFF the SERVOPACK power supply and then turn it ON again to validate the new setting.		

## 6.7 Clearing Alarm History (Fn006)

The clear alarm history function deletes all of the alarm history recorded in the SERVOPACK.

Note: The alarm history can be deleted only with this function. The alarm history is not deleted when the alarm reset is executed or the main circuit power supply of the SERVOPACK is turned OFF.

Follow the steps below to clear the alarm history.

Step	Display Example	Keys	Operation
1	<pre>BB      -FUNCTION- Fn005:Prm Init Fn006:AlmHist Clr Fn008:Mturn Clr Fn009:Ref Adj</pre>	  	<p>Press the  Key to view the main menu for the utility function mode.</p> <p>Use the  or  Key to move through the list, select Fn006.</p>
2	<pre>BB Alarm History   Data Clear   Start : [DATA]   Return: [SET]</pre>		<p>Press the  Key. The display is switched to the execution display of Fn006.</p> <p>Note: If the display is not switched and “NO-OP” is displayed in the status display, the Write Prohibited Setting (Fn010 = 0001) is set. Check the setting and reset. (Refer to 6.12.)</p>
3	<pre>DONE Alarm History   Data Clear   Start : [DATA]   Return: [SET]</pre>		<p>Press the  Key to clear the alarm history. While clearing the data, “DONE” is displayed in the status display. After the data has been successfully cleared, “BB” is displayed.</p> <p>Note: Press the  Key not to clear the alarm history. The display returns to the Utility Function Mode main menu.</p>

## 6.8 Offset Adjustment of Analog Monitor Output (Fn00C)

This function is used to manually adjust the offsets for the analog monitor outputs (force reference monitor output and motor speed monitor output). The offsets for the force reference monitor output and motor speed monitor output can be adjusted individually. The offset values are factory-set before shipping. Therefore, the user need not usually use this function.

### (1) Adjustment Example

An example of offset adjustment to the motor speed monitor is shown below.

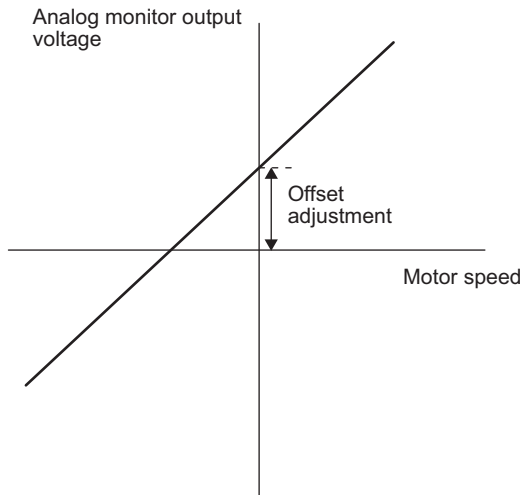









Item	Specifications
Zero-adjustment Range	-2.4 V to +2.4 V
Adjustment Unit	18.9 mV/LSB















#### <Notes>

- Offset adjustment cannot be made if write protection is set in Fn010.
- The adjustment value will not be initialized when parameter settings are initialized using Fn005.
- Make offset adjustment with a measuring instrument connected, so that the analog monitor output is zero. An example of settings for a zero analog monitor output is shown below.
  - While the motor is not turned ON, set the monitor signal to the force reference.
  - In speed control, set the monitor signal to the position error.

### (2) Operating Procedure

Follow the steps below to perform the offset adjustment of analog monitor output.

Step	Display Example	Keys	Operation
1	<pre> BB      -FUNCTION- Fn00B:Trq Adj Fn00C:MonZero Adj Fn00D:MonGain Adj Fn00E:Cur AutoAdj           </pre>	  	Press the  Key to view the main menu for the utility function mode. Use the  or  Key to move through the list, select Fn00C.
2	<pre> BB      -Zero ADJ- CH1=-0000<u>2</u> CH2= 00001 Un002= 00000 Un000= 00000           </pre>		Press the  Key. The display is switched to the execution display of Fn00C. Note: If the display is not switched and “NO-OP” is displayed in the status display, the Write Prohibited Setting (Fn010 = 0001) is set. Check the setting and reset. (Refer to 6.12.)

Step	Display Example	Keys	Operation
3	<pre> BB      -Zero ADJ- CH1=-0000<u>5</u> CH2= 00001 Un002= 00000 Un000= 00000 </pre>	 	<p>Press the  or  Key to adjust the offset of CH1 (force reference monitor). Adjust the offset so that the measurement instrument reading is as close to 0 V as possible.</p>
4	<pre> BB      -Zero ADJ- CH1=-00005 CH2= 0000<u>1</u> Un002= 00000 </pre>		<p>After the offset adjustment of CH1 has completed, press the  Key. The cursor moves to CH2 (motor speed monitor) side.</p>
5	<pre> BB      -Zero ADJ- CH1=-00005 CH2= 0000<u>6</u> Un002= 00000 Un000= 00000 </pre>	 	<p>Press the  or  Key to adjust the offset of CH2. Adjust the offset so that the measurement instrument reading is as close to 0 V as possible.</p>
6	<pre> DONE    -Zero ADJ- CH1=-00005 CH2= 0000<u>6</u> Un002= 00000 Un000= 00000 </pre>		<p>After having completed the offset adjustment both for CH1 and CH2, press the  Key. The adjustment results are saved in the SERVO-PACK. "DONE" is displayed in the status display after saving is completed.</p>
7	<pre> BB      -FUNCTION- Fn00B:Trq Adj Fn00C:MonZero Adj Fn00D:MonGain Adj Fn00E:Cur AutoAdj </pre>		<p>Press the  Key to return to the Utility Function Mode main menu.</p>

## 6.9 Gain Adjustment of Analog Monitor Output (Fn00D)

This function is used to manually adjust the gains for the analog monitor outputs (force reference monitor output and motor speed monitor output). The gains for the force reference monitor output and motor speed monitor output can be adjusted individually. The gain values are factory-set before shipping. Therefore, the user need not usually use this function.

### (1) Adjustment Example

An example of gains adjustment to the motor speed monitor is shown below.

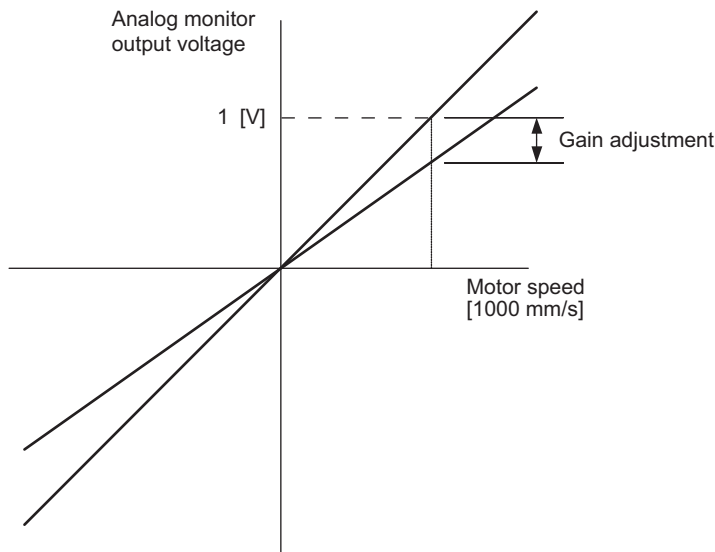

Item	Specifications
Gain-adjustment Range	50% to 150%
Adjustment Unit	0.4%/LSB

The gain adjustment width is made with a 100% output set as a center value (adjustment range: 50% to 150%). A setting example is shown below.

#### <Setting the Set Value to -125>

$$100\% + (-125 \times 0.4) = 50\%$$

Therefore, the monitor output voltage is 0.5 times as high.

#### <Setting the Set Value to 125>

$$100\% + (125 \times 0.4) = 150\%$$























Therefore, the monitor output voltage is 1.5 times as high.

#### <Notes>

- Gain adjustment cannot be made if write protection is set in Fn010.
- The adjustment value will not be initialized when parameter settings are initialized using Fn005.

## (2) Operating Procedure

Follow the steps below to perform the gain adjustment of analog monitor output.

Step	Display Example	Keys	Operation
1	<pre>BB      -FUNCTION- Fn00C: MonZero Adj Fn00D: MonGain Adj Fn00E: Cur AutoAdj Fn00F: Cur ManuAdj</pre>	  	<p>Press the  Key to view the main menu for the utility function mode.</p> <p>Use the  or  Key to move through the list, select Fn00D.</p>
2	<pre>BB      -Gain ADJ- CH1=-0000<u>1</u> CH2=-00001 Un002= 00000 Un000= 00000</pre>		<p>Press the  Key. The display is switched to the execution display of Fn00D.</p> <p>Note: If the display is not switched and “NO-OP” is displayed in the status display, the Write Prohibited Setting (Fn010 = 0001) is set. Check the setting and reset. (Refer to 6.12.)</p>
3	<pre>BB      -Gain ADJ- CH1= 0012<u>5</u> CH2=-00001 Un002= 00000 Un000= 00000</pre>	 	<p>Press the  or  Key to adjust the gain adjustment width of CH1 (force reference monitor).</p>
4	<pre>BB      -Gain ADJ- CH1= 00125 CH2=-0000<u>1</u> Un002= 00000 Un000= 00000</pre>		<p>After the gain adjustment of CH1, press the  Key. The cursor moves to CH2 (motor speed monitor) side.</p>
5	<pre>BB      -Gain ADJ- CH1= 00125 CH2=-0012<u>5</u> Un002= 00000 Un000= 00000</pre>	 	<p>Press the  or  Key to adjust the gain adjustment width of CH2.</p>
6	<pre>DONE    -Gain ADJ- CH1= 00125 CH2=-0012<u>5</u> Un002= 00000 Un000= 00000</pre>		<p>After having completed the adjustment both for CH1 and CH2, press the  Key.</p> <p>The adjustment results are saved in the SERVO-PACK. After the saving is completed, “DONE” is displayed in the status display.</p>
7	<pre>BB      -FUNCTION- Fn00C: MonZero Adj Fn00D: MonGain Adj Fn00E: Cur AutoAdj Fn00F: Cur ManuAdj</pre>		<p>Press the  Key to return to the Utility Function Mode main menu.</p>



## 6.10 Automatic Offset-Signal Adjustment of the Motor Current Detection (Fn00E)













Perform this adjustment only if highly accurate adjustment is required for reducing force ripple. Basically, the user need not perform this adjustment.



IMPORTANT

- Be sure to perform this function while the linear servomotor power is OFF.
- Execute the automatic offset adjustment if the force ripple is too big when compared with that of other SERVOPACKs.

Follow the steps below.























Step	Display Example	Keys	Operation
1	<pre> BB      -FUNCTION- Fn00D: MonGain Adj Fn00E: Cur AutoAdj Fn00F: Cur ManuAdj Fn010: Prm Protect           </pre>	  	<p>Press the  Key to view the main menu for the utility function mode.</p> <p>Use the  or  Key to move through the list, select Fn00E.</p>
2	<pre> BB Auto Offset-ADJ of Motor Current Start : [DATA] Return: [SET]           </pre>		<p>Press the  Key. The display is switched to the execution display of Fn00E.</p> <p>Note: If the display is not switched and “NO-OP” is displayed in the status display, change the following settings. (Refer to 6.12.)</p> <ul style="list-style-type: none"> <li>• If Write Prohibited is set in Fn010: → Cancel the Write Prohibited setting.</li> <li>• If a servo ON command is input: → Send a servo OFF command.</li> </ul>
3	<pre> DONE Auto Offset-ADJ of Motor Current Start : [DATA] Return: [SET]           </pre>	 	<p>Press the  Key to start the automatic offset-signal adjustment of motor current detection.</p> <p>When the adjustment is completed, “DONE” is displayed in the status display.</p> <p>Note: Press the  Key to cancel the automatic adjustment. The display returns to the Utility Function Mode main menu.</p>

## 6.11 Manual Offset-Signal Adjustment of the Motor Current Detection (Fn00F)

Use this function only if the force ripple is still high after the automatic offset adjustment of the motor current detection signal (Fn00E).

 <b>IMPORTANT</b>	<p>If this function is executed carelessly, it may worsen the characteristics. Observe the following precautions when performing manual servo tuning.</p> <ul style="list-style-type: none"> <li>• Run the linear servomotor at a speed of approximately 100 mm/s.</li> <li>• Adjust the offset until the force reference monitor ripple is minimized, monitoring the force reference by using the analog monitor.</li> <li>• Adjust the offset amounts of phase U and phase V of the linear servomotor alternately several times until these offsets are well balanced.</li> </ul>
---	---

Follow the steps below.

Step	Display Example	Keys	Operation
1	<pre> RUN      -FUNCTION- Fn00F: Cur ManuAdj Fn010: Prm Protect Fn011: Motor Info Fn012: Soft Ver           </pre>	  	<p>Press the  Key to view the main menu for the utility function mode.</p> <p>Use the  or  Key to move through the list, select Fn00F.</p>
2	<pre> RUN Manual Offset-ADJ of Motor Current ZADJIU= 0000<u>9</u> ZADJIV= 00006           </pre>		<p>Press the  Key. The display is switched to the execution display of Fn00F.</p> <p>Note: If the display is not switched and “NO-OP” is displayed in the status display, the Write Prohibited Setting (Fn010 = 0001) is set. Check the setting and reset. (Refer to 6.12.)</p>
3	<pre> RUN Manual Offset-ADJ of Motor Current ZADJIU= 0001<u>9</u> ZADJIV= 00006           </pre>	 	<p>Press the  or  Key to adjust the offset amount of phase-U.</p> <p>Adjust the offset amount by 10 in the direction that the force ripple is reduced.</p> <p>Adjustment range: -512 to +511</p>
4	<pre> RUN Manual Offset-ADJ of Motor Current ZADJIU= 00019 ZADJIV= 0000<u>6</u>           </pre>		<p>Press the  Key. The cursor moves to the phase-V side.</p>
5	<pre> RUN Manual Offset-ADJ of Motor Current ZADJIU= 00019 ZADJIV= 0001<u>6</u>           </pre>	 	<p>Press the  or  Key to adjust the offset amount of phase-V.</p> <p>Adjust the offset amount by 10 in the direction that the force ripple is reduced.</p> <p>Adjustment range: -512 to +511</p>
6	<p>Repeat the above operations (phase-U and-V alternately) until adjusting the offset amounts both for phase-U and -V in both directions cannot reduce the force ripple any more. Then, perform the same operation by adjusting by smaller amount.</p>		
7	<pre> DONE Manual Offset-ADJ of Motor Current ZADJIU= 00019 ZADJIV= 0001<u>6</u>           </pre>		<p>Press the  Key to save the result of adjustment in the SERVOPACK.</p> <p>When the saving is completed, “DONE” is displayed in the status display.</p>
8	<pre> RUN      -FUNCTION- Fn00F: Cur ManuAdj Fn010: Prm Protect Fn011: Motor Info Fn012: Soft Ver           </pre>		<p>Press the  Key to return to the Utility Function Mode main menu.</p>

## 6.12 Write Prohibited Setting (Fn010)

Prohibiting writing prevents writing parameters by mistake.

The following operations can be write-protected using the Fn010 parameter.

- Parameter settings from the digital operator (Pn□□□)
- Utility functions shown in (1) *Utility Functions That Can Be Write-protected* (Fn□□□)

### (1) Utility Functions That Can Be Write-protected

Function No.	Function	Write Prohibited Setting	Reference Section
Fn000	Alarm history display	×	6.2
Fn002	JOG operation	○	6.3
Fn003	Origin search	○	6.4
Fn004	Program JOG operation	○	6.5
Fn005	Initializing parameter settings	○	6.6
Fn006	Clearing alarm history	○	6.7
Fn00C	Offset adjustment of analog monitor output	○	6.8
Fn00D	Gain adjustment of analog monitor output	○	6.9
Fn00E	Automatic offset-signal adjustment of motor current detection signal	○	6.10
Fn00F	Manual offset-signal adjustment of motor current detection signal	○	6.11
Fn010	Write prohibited setting	–	6.12
Fn011	Servomotor model display	×	6.13
Fn012	Software version display	×	6.14
Fn014	Resetting configuration error of option module	○	6.15
Fn01B	Vibration detection level initialization	○	6.16
Fn01E	Display of SERVOPACK and servomotor ID	×	6.17
Fn020	Origin setting	×	4.5.3
Fn030	Software reset	×	6.18
Fn080	Polarity detection	×	4.5.2
Fn200	Tuning-less level setting	○	5.2.2
Fn201	Advanced autotuning	○	5.3.2
Fn202	Advanced autotuning by reference	○	5.4.2
Fn203	One-parameter tuning	○	5.5.2
Fn204	Anti-resonance control adjustment function	○	5.6.2
Fn205	Vibration suppression function	○	5.7.2
Fn206	EasyFFT	○	6.19
Fn207	Online vibration monitor	○	6.20

Note 1. ○: Possible, ×: Impossible















2. If the write prohibited setting (Fn010) is enabled, “NO-OP” is displayed on the status display of the Digital Operator if the user attempts to execute the above utility functions. To execute these utility functions, set Fn010 to write permitted by using the procedure shown in (2) *Operating Procedure*.

## (2) Operating Procedure

Follow the steps below to set “write prohibited” or “write permitted.”

Setting values are as follows:











- “P.0000”: Write permitted (Releases write prohibited mode.) [Factory setting]
- “P.0001”: Write prohibited (Parameters become write prohibited from the next power ON.)

Step	Display Example	Keys	Operation
1	<pre> BB      -FUNCTION- Fn00F:Cur ManuAdj Fn010:Prm Protect Fn011:Motor Info Fn012:Soft Ver           </pre>	  	<p>Press the  Key to view the main menu for the utility function mode.</p> <p>Use the  or  Key to move through the list, select Fn010.</p>
2	<pre> BB Parameter Write Protect  P. 000<u>0</u>           </pre>		<p>Press the  Key. The display switches to the execution display of Fn010.</p>
3	<pre> BB Parameter Write Protect  P. 000<u>1</u>           </pre>	 	<p>Press the  Key to select one of the following settings.</p> <p>P.0000: Write permitted [Factory setting] P.0001: Write prohibited</p>
4	<pre> DONE Parameter Write Protect  P. 000<u>1</u>           </pre>		<p>Press the  Key to save the setting value in the SERVOPACK. When the saving is completed, “DONE” is displayed in the status display.</p>
5	<pre> BB      -FUNCTION- Fn00F:Cur ManuAdj Fn010:Prm Protect Fn011:Motor Info Fn012:Soft Ver           </pre>		<p>Press the  Key to return to the Utility Function Mode main menu.</p>
6	Turn OFF the SERVOPACK power supply and then turn it ON again to validate the new setting.		

## 6.13 Servomotor Model Display (Fn011)

This function is used to check the linear servomotor model, voltage, capacity, linear scale type, and encoder resolution. If the SERVOPACK has been custom-made, you can also check the specification codes of SERVOPACKs.

Follow the steps below.

Step	Display Example	Keys	Operation
1	<pre> RUN  -FUNCTION- Fn010: Prm Protect Fn011: Motor Info Fn012: Soft Ver Fn013: MturnLmSet           </pre>	  	Press the  Key to view the main menu for the utility function mode. Use the  or  Key to move through the list, select Fn011.
2	<pre> BB  -MotorInfo- TYPE 40 AC200V       400W ENCODER 01 8bit           </pre> <p>(Example)</p>		Press the  Key to switch to the display of Fn011.
3	<pre> RUN  -FUNCTION- Fn010: Prm Protect Fn011: Motor Info Fn012: Soft Ver Fn013: MturnLmSet           </pre>		Press the  Key to return to the Utility Function Mode main menu.



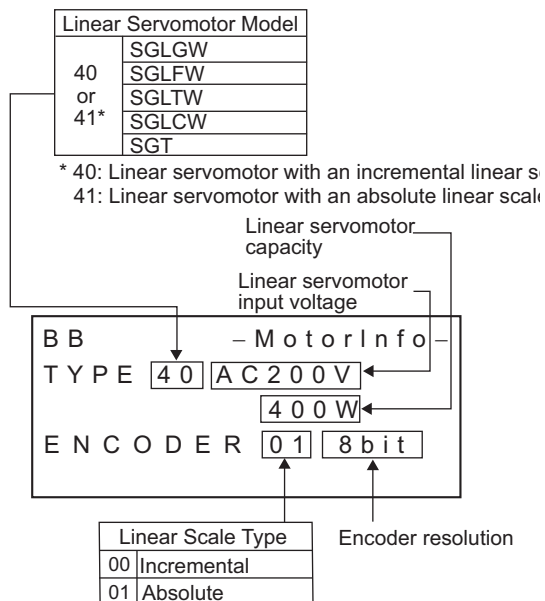















### ■ Display Designation



## 6.14 Software Version Display (Fn012)

Select Fn012 to check the SERVOPACK and linear scale software version numbers.

Follow the steps below.

Step	Display Example	Keys	Operation
1	<pre>BB      -FUNCTION- Fn011:Motor Info Fn012:Soft Ver Fn013:MturnLmSet Fn014:Opt Init</pre>	  	<p>Press the  Key to view the main menu for the utility function mode.</p> <p>Use the  or  Key to move through the list, select Fn012.</p>
2	<pre>BB      -Soft Ver- DRIVER Ver.=0001 ENCODER Ver.=0003</pre>		<p>Press the  Key. The software versions of the SERVOPACK and the connected linear scale will be displayed.</p> <p>Note: If the linear servomotor is not connected, “Not connect” is displayed under “ENCODER” instead of the version number.</p>
3	<pre>BB      -Soft Ver- OPTION ENCODER Ver.=0001</pre>		<p>Press the  Key. The software version of the linear scale will be displayed.</p> <p>Note: If a linear scale is not connected, “Not connect” will be displayed.</p>
4	<pre>BB      -Soft Ver- COMMAND Ver.=0001</pre>		<p>Press the  Key. The software version of the command option module will be displayed.</p> <p>Note: If a command option module is not connected, “Not connect” will be displayed.</p>
5	<pre>BB      -Soft Ver- SAFETY Ver.=0001</pre>		<p>Press the  Key. The software version of the safety option module will be displayed.</p> <p>Note: If a safety option module is not connected, “Not connect” will be displayed.</p>
6	<pre>BB      -Soft Ver- FEEDBACK Ver.=0001</pre>		<p>Press the  Key. The software version of the feedback option module will be displayed.</p> <p>Note: If a feedback option module is not connected, “Not connect” will be displayed.</p>
7	<pre>BB      -FUNCTION- Fn011:Motor Info Fn012:Soft Ver Fn013:MturnLmSet Fn014:Opt Init</pre>		<p>Press the  Key to return to the Utility Function Mode main menu.</p>

## 6.15 Resetting Configuration Error of Option Module (Fn014)

The SERVOPACK with option module recognizes installation status and types of option module which is connected to SERVOPACK. If an error is detected, the SERVOPACK issues an alarm.

This function resets the following alarms.

- Command Option Module Unmatched Error (A.E80)
- Feedback Option Module Detection Failure (A.E72)



















For alarm types and corrective actions, refer to 8 *Troubleshooting*.

Note 1. The alarms above can be cleared only by this function. These alarms cannot be cleared by alarm reset or turning OFF the SERVOPACK main circuit power supply.

2. Before clearing the alarm, perform corrective action for the alarm.

### (1) Operating Procedure

Follow the steps below.

Step	Display Example	Keys	Operation
1	<pre> BB      - FUNCTION - Fn013:MturnLmSet Fn014:Opt Init Fn01B:Vibl_vl Init Fn01E:SvMotOp ID           </pre>	  	<p>Press the  Key to view the main menu for the utility function mode.</p> <p>Use the  or  Key to move through the list, select Fn014.</p>
2	<pre> BB      - Opt Init - 01:Command Opt 02:Safety Opt 03:Feedback Opt           </pre>		<p>Press the  Key. The display changes to the execution display of Fn014.</p>
3	<pre> BB      - Opt Init - Command Opt Initialize Start  :[DATA] Return:[SET]           </pre>	  	<p>Press the  or  Key to select an option module to be cleared and then press the  Key.</p> <p>Note: If the display is not switched and “NO-OP” is displayed in the status display, the Write Prohibited Setting (Fn010 = 0001) is set. Check the setting and reset. (Refer to 6.12.)</p>
4	<pre> DONE    - Opt Init - Command Opt Initialize Start  :[DATA] Return:[SET]           </pre>		<p>Press the  Key again to clear the configuration error of the option module.</p>
5	<pre> RUN     - FUNCTION - Fn013:MturnLmSet Fn014:Opt Init Fn01B:Vibl_vl Init Fn01E:SvMotOp ID           </pre>		<p>Press the  key to return to the Utility Function Mode main menu.</p>
6	Turn OFF the SERVOPACK power supply and then turn it ON again to validate the new setting.		

## 6.16 Vibration Detection Level Initialization (Fn01B)

This function detects vibration when linear servomotor is connected to a machine and automatically adjusts the vibration detection level (Pn384) to output more exactly the vibration alarm (A.520) or warning (A.911).

The vibration detection function detects vibration elements according to the linear servomotor speed.

Parameter	Meaning	When Enabled	Classification	
Pn310	n.□□□0	Does not detect vibration. (Factory setting)	Immediately	Setup
	n.□□□1	Outputs the warning (A.911) when vibration is detected.		
	n.□□□2	Outputs the alarm (A.520) when vibration is detected.		

If the vibration exceeds the detection level calculated by the following formula, the alarm or warning will be output according to the setting of vibration detection switch (Pn310).

$$\text{Detection level} = \frac{\text{Vibration detection level (Pn384 [mm/s])} \times \text{Detection sensibility (Pn311 [\%])}{100}$$

### <Notes>

- Use this function if the vibration alarm (A520) or vibration warning (A.911) is not displayed at a correct timing when a vibration is detected at the factory-setting level of Pn384 (Vibration Detection Level.)
- The vibration alarm or warning detection sensibility differs depending on the machine conditions. In this case, a detection sensibility fine adjustment can be set in the detection sensibility Pn311.











**IMPORTANT**







- The vibration may not be detected because of improper servo gains. Also, not all kinds of vibrations can be detected. Use the detection result as a guideline.
- Set a proper mass ratio (Pn103). Improper setting may result in the vibration alarm, warning misdetection, or non-detection.
- The references that are used to operate your system must be input to execute this function.
- Execute this function under the operation condition for which the vibration detection level should be set.
- Execute this function to set the vibration detection level while the motor speed reaches at least 10% of its maximum.

### (1) Operating Procedure

Follow the steps to adjust the parameter Pn384.







Step	Display Example	Keys	Operation
1	<pre> RUN      - FUNCTION - Fn014: Opt Init Fn01B: Vibl_vl Init Fn01E: SvMotOp ID Fn01F: FBOpMot ID           </pre>	  	<p>Press the  Key to view the main menu for the utility function mode.</p> <p>Use the  or  Key to move through the list, select Fn01B.</p>
2	<pre> RUN Vibration Detect Level Init Start : [DATA] Return: [SET]           </pre>		<p>Press the  Key. The display is switched to the execution display of Fn01B.</p> <p>Note: If the display is not switched and “NO-OP” is displayed in the status display, the Write Prohibited Setting (Fn010 = 0001) is set. Check the setting and reset. (Refer to 6.12.)</p>



Step	Display Example	Keys	Operation
3	<pre> RUN Vibration Detect Level Init  Init </pre>		<p>Press the  Key.</p> <p>“Init” is displayed blinking, and the vibration level is detected and adjusted. Detection and adjustment continue until the  Key is pressed again.</p> <p>Notes:</p> <ul style="list-style-type: none"> <li>• Operate the SERVOPACK with the references that will be used for actual operation.</li> <li>• If the linear servomotor is moving at 10% or less of the maximum speed, “Error” will be displayed.</li> </ul>
4	<pre> DONE Vibration Detect Level Init  DONE </pre>		<p>Press the  Key. The display changes from “Init” to “DONE,” and the setting becomes enabled.</p>
5	<pre> RUN          -FUNCTION- Fn014:Opt Init Fn01B:Vibl_vl Init Fn01E:Sv Mot Op ID Fn01F:FB Op Mot ID </pre>		<p>Press the  key to return to the Utility Function Mode main menu.</p>

## (2) Related Parameters

Use the following parameters as required.

<b>Pn311</b>	Vibration Detection Sensibility   				Classification
	Setting Range	Setting Unit	Factory Setting	When Enabled	
	50 to 500	1%	100	Immediately	Tuning
<b>Pn384</b>	Vibration Detection Level   				Classification
	Setting Range	Setting Unit	Factory Setting	When Enabled	
	0 to 5000	1 mm/s	50	Immediately	Tuning

Note: Vibration Detection Level (Pn384) is set by Fn01B (Vibration Detection Level Initialization) automatically, so it is not necessary to adjust it.

## 6.17 Display of SERVOPACK and Servomotor ID (Fn01E)

This function displays ID information for SERVOPACK, linear servomotor, linear scale and option module connected to the SERVOPACK. Note that the ID information of some option modules is not stored in the SERVOPACK. “Not available” will be displayed for these option modules.

The following items can be displayed.

ID	Items to be Displayed
SERVOPACK	<ul style="list-style-type: none"> <li>• SERVOPACK model</li> <li>• SERVOPACK serial number</li> <li>• SERVOPACK manufacturing date</li> <li>• SERVOPACK input voltage (V)</li> <li>• Maximum applicable motor capacity (W)</li> <li>• Maximum applicable motor rated current (Arms)</li> </ul>
Servomotor	<ul style="list-style-type: none"> <li>• Servomotor model</li> <li>• Servomotor order number</li> <li>• Servomotor manufacturing date</li> <li>• Servomotor input voltage (V)</li> <li>• Servomotor capacity (W)</li> <li>• Servomotor rated current (Arms)</li> </ul>
Encoder	<ul style="list-style-type: none"> <li>• Linear scale model</li> <li>• Linear scale serial number</li> <li>• Linear scale manufacturing date</li> <li>• Linear scale type/resolution</li> </ul>
Command Option Module*	<ul style="list-style-type: none"> <li>• Command option module model</li> <li>• Command option module serial number</li> <li>• Command option module manufacturing date</li> <li>• Command option module ID number</li> </ul>
Safety Option Module*	<ul style="list-style-type: none"> <li>• Safety option module model</li> <li>• Safety option module serial number</li> <li>• Safety option module manufacturing date</li> <li>• Safety option module ID number</li> </ul>
Feedback Option Module*	<ul style="list-style-type: none"> <li>• Feedback option module model</li> <li>• Feedback option module serial number (Reserved area)</li> <li>• Feedback option module manufacturing date</li> <li>• Feedback option module ID</li> </ul>

\* If an option module is not connected, “Not connect” will be displayed after the module name.

## 6.18 Software Reset (Fn030)

This function enables resetting the SERVOPACK internally from software. The operation of turning OFF the power and then turning ON again to validate the setting can be omitted by executing this function.

 <b>IMPORTANT</b>	<ul style="list-style-type: none"> <li>• Start software reset operation when the servomotor power is OFF.</li> <li>• This function resets the SERVOPACK independently from host controller. The SERVOPACK carries out the same processing as when the power supply is turned ON and outputs the ALM signal. The status of other output signals may be forcibly changed.</li> </ul>
---	--

















### (1) Setting before Operation

The following settings are required before executing the software reset function.

- If a servo ON command is input, send a servo OFF command.

### (2) Operating Procedure

Follow the steps below to reset the SERVOPACK internally.

Step	Display Example	Keys	Operation
1	<pre> BB      - FUNCTION - Fn020: S-Orig Set Fn030: Soft Reset Fn080: Pole Detect Fn200: TuneLvl Set           </pre>	  	Press the  Key to view the main menu for the utility function mode. Use the  or  Key to move through the list, select Fn030.
2	<pre> BB Software Reset RESET1           </pre>		Press the  Key. The display is switched to the execution display of Fn030.
3	<pre> BB Software Reset RESET5           </pre>	 	Press the  or  Key to select RESET5.
4	<pre> BB Software Reset           </pre>		Press the  Key to execute the software reset. "RESET5" is no longer displayed.
5	<pre> File First Loading Please Wait...           </pre>		After the reset has been successfully completed, the screen which appears when the power is turned ON will be displayed. Then, the mode changes to the parameter/monitor display mode.
6	<pre> BB      - FUNCTION - Fn020: S-Orig Set Fn030: Soft Reset Fn080: Pole Detect Fn200: TuneLvl Set           </pre>		Press the  Key to return to the Utility Function Mode main menu.

## 6.19 EasyFFT (Fn206)

EasyFFT sends a frequency waveform reference from the SERVOPACK to the linear servomotor and moves the linear servomotor at minimal speed a number of times over a certain period, thus causing machine vibration. The SERVOPACK detects the resonance frequency from the generated vibration and makes notch filter settings according to the resonance frequency detection. The notch filter is effective for the elimination of high-frequency vibration and noise.

### ⚠ WARNING

- The linear servomotor moves at minimal speed when EasyFFT is executed. Do not touch the linear servomotor or machine during execution of EasyFFT, otherwise injury may result.

### ⚠ CAUTION

- Use the EasyFFT when the servo gain is low, such as in the initial stage of servo adjustment. If EasyFFT is executed after increasing the gain, the servo system may vibrate depending on the machine characteristics or gain balance.

Machine vibration may be suppressed by setting a notch filter according to the detected vibration frequency.

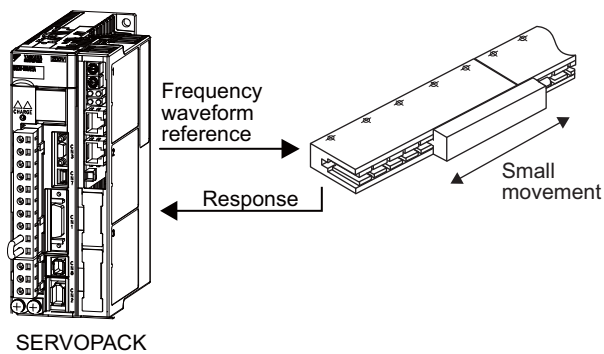

In addition to this function, Online Vibration Monitor (Fn207) can be used to detect machine vibration and automatically make notch filter settings. Use the following flowchart to determine which function should be used.

When using mainly for servo gain adjustment, etc.

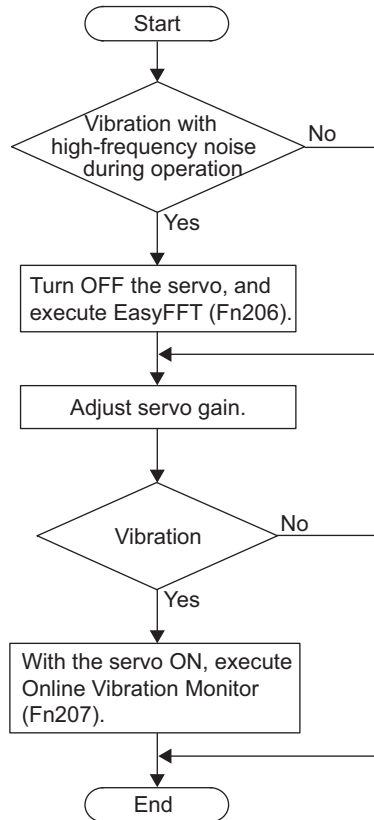





























IMPORTANT

- Starts EasyFFT when the linear servomotor power is OFF.
- Do not input the reference from outside because EasyFFT outputs the special reference from the SERVOPACK.

## (1) Operating Procedure

Follow the steps below.

Step	Display Example	Keys	Operation
1	<pre>BB      -FUNCTION- Fn205:Vib Sup Fn206:Easy FFT Fn207:V-Monitor Fn000:Alm History</pre>	  	<p>Press the  Key to view the main menu for the utility function mode.</p> <p>Use the  or  Key to move through the list, select Fn206.</p>
2	<pre>BB      -Easy FFT- Setting Input = 015%</pre>		<p>Press the  Key. The display is switched to the execution display of Fn206.</p> <p>Note: If the display is not switched and “NO-OP” is displayed in the status display, change the following settings. (Refer to 6.12.)</p> <ul style="list-style-type: none"> <li>• If Write Prohibit is set in Fn010: → Cancel the Write Prohibited setting.</li> <li>• If a servo ON command is input: → Send a servo OFF command.</li> </ul>
3	<pre>BB      -Easy FFT- Setting Input = 015%</pre>	 	<p>The cursor is on the setting of "Input." Press the  or  Key to set the sweep force reference amplitude (Pn456). Setting range: 1 to 800.</p> <p>Note: When making the initial settings for EasyFFT, do not change the setting for the reference amplitude. Start with the original value of 15. Increasing reference amplitude increases the detection accuracy, but the vibration and noise from the machine will increase. Increase the amplitude value little by little.</p>
4	<pre>RUN     -Easy FFT- Ready Input = 015%</pre>		<p>Press the  Key to turn the linear servomotor power ON. The display “BB” and “Setting” changes to “RUN” and “Ready.”</p>
5	<pre>RUN     -Easy FFT- Measure Input = 015%</pre>	 	<p>Press the  (forward run start) Key or  (reverse run start) Key to run the linear servomotor and start the frequency measurement. "Measure" is displayed blinking during the measurement.</p> <p>&lt;Linear Servomotor Movement during Detection&gt; Within 10 mm, the linear servomotor will move forward and then in reverse several times. The total operation time is between 1 and 45 seconds.</p> <p>Note: The actions of the linear servomotor are very minute in this operation. Also at the same time, the linear servomotor emits a noise. To ensure safety, do not enter the working envelopment of the machine.</p>

Step	Display Example	Keys	Operation
6	<pre> RUN      -Easy FFT- Result Input = 015 % Res =    1250 Hz Filter1 1375 Hz </pre>		<p>When the detection has completed normally, the result and the notch filter value to be set are displayed.</p> <p>Press the  Key to turn OFF the power to the servomotor.</p> <p>&lt; Important &gt;</p> <p>If 2 seconds or more are required for the operation although detection was successfully completed, the detection accuracy might be insufficient. Increasing reference amplitude more than 15 increases the detection accuracy, but the vibration and noise from the machine will increase. Increase the amplitude value little by little.</p> <p>Notes:</p> <ul style="list-style-type: none"> <li>• If a notch filter has been set and is being used, "*" is displayed on the second line.</li> <li>• If the first notch filter has been set, the second notch filter value is displayed. If the first and second notch filters have been set, only the result of frequency detection is displayed.</li> <li>• If the  Key is pressed while the linear servomotor is running, the linear servomotor will stop, and the frequency detection will be canceled.</li> <li>• If the detection is not completed normally, "No Measure" is displayed.</li> </ul>
7	<pre> RUN      -Easy FFT- Ready Input = 015% </pre>	 	<p>Press the  Key to exit the EasyFFT function at this stage. The power to the linear servomotor is turned OFF and the display returns to the Utility Function Mode main menu.</p> <p>Press the  Key to return to "Ready" display.</p>
8	<pre> DONE     -Easy FFT- Result Input = 015 % Res =    1250 Hz Filter1 1375 Hz </pre>		<p>Press the  Key after the normal completion of frequency detection. The notch filter frequencies are automatically updated to the optimum values. If the first notch filter frequency has been set (Pn408.0 = 1), set the second notch filter frequency (Pn40C).</p> <p>Notes:</p> <ul style="list-style-type: none"> <li>• If the second notch filter frequency has already been set (Pn408.2 = 1), the notch filter frequency cannot be set.</li> <li>• If the frequency detected by this function is not used, set the notch filter to be invalid (Pn408.0 = 0).</li> </ul>
9	<pre> BB      -FUNCTION- Fn205: Vib Sup Fn206: Easy FFT Fn207: V-Monitor Fn000: Alm History </pre>		<p>Press the  Key to return to the Utility Function Mode main menu.</p>
10	Turn OFF the SERVOPACK power supply and then turn ON again to validate the setting.		

## (2) Related Parameters

The Easy FFT related parameters are listed below. These parameters will be automatically set and the user need not set them manually.

Parameter	Meaning	When Enabled	Classification	
<b>Pn408</b>	n.□□□0	Disables 1st notch filter. (Factory setting)	Immediately	Setup
	n.□□□1	Uses 1st notch filter.		
	n.□0□□	Disables 2nd notch filter. (Factory setting)		
	n.□1□□	Uses 2nd notch filter.		

<b>Pn409</b>	1st Notch Filter Frequency <input type="text" value="Speed"/> <input type="text" value="Position"/> <input type="text" value="Force"/>				Classification
	Setting Range	Setting Unit	Factory Setting	When Enabled	
	50 to 5000	1 Hz	5000	Immediately	Tuning

<b>Pn40C</b>	2nd Notch Filter Frequency <input type="text" value="Speed"/> <input type="text" value="Position"/> <input type="text" value="Force"/>				Classification
	Setting Range	Setting Unit	Factory Setting	When Enabled	
	50 to 5000	1 Hz	5000	Immediately	Tuning

<b>Pn456</b>	Sweep Force Reference Amplitude <input type="text" value="Speed"/> <input type="text" value="Position"/> <input type="text" value="Force"/>				Classification
	Setting Range	Setting Unit	Factory Setting	When Enabled	
	1 to 800	1%	15	Immediately	Tuning



## 6.20 Online Vibration Monitor (Fn207)

The machine vibration can sometimes be suppressed by setting a notch filter or force reference filter for the vibration frequencies.

When online, vibration frequencies caused by machine resonance will be detected and the frequency that has the highest peak will be displayed on the Panel Operator. The effective force reference filter or notch filter frequency for the vibration frequency will be automatically selected and the related parameters will be automatically set.





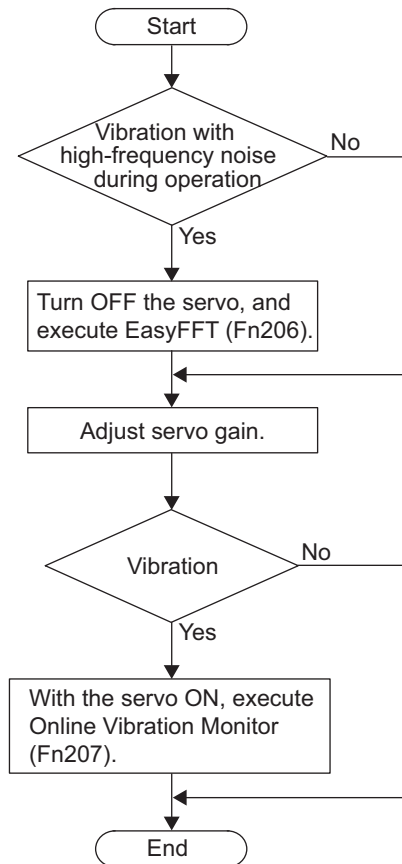









In addition to this function, EasyFFT (Fn206) can be used to detect machine vibration and automatically make notch filter settings. Use the following flowchart to determine which function should be used.

When using mainly for servo gain adjustment, etc.



## (1) Operating Procedure

Follow the steps below.

Step	Display Example	Keys	Operation
1	<pre> RUN      -FUNCTION- Fn206: Easy FFT Fn207: V-Monitor Fn000: Alm History Fn001: JOG           </pre>	  	<p>Press the  Key to view the main menu for the utility function mode.</p> <p>Use the  or  Key to move through the list, select Fn207.</p>
2	<pre> RUN      -V-MONITOR- Measure F1=----- F2=----- F3=-----           </pre>		<p>Press the  Key. The display is switched to the execution display of Fn207.</p> <p>Note: If the display is not switched and “NO-OP” is displayed in the status display, the Write Prohibit is set in Fn010. Check the setting and reset. (Refer to 6.12.)</p>
3	<pre> RUN      -V-MONITOR- Measure F1=----- F2=----- F3=-----           </pre>		<p>Press the  Key for 1 second.</p> <p>The message, “Measure,” blinks, and vibration detection will start.</p>
4	<pre> RUN      -V-MONITOR- Measure F1= 0850 [Hz] F2= 1600 [Hz] F3= 0225 [Hz]           </pre>		<p>When the vibration detection has completed, “Measure” stops blinking and the detection ends automatically. When the detection has completed normally, the vibrations with three largest peak values in vibration frequency are displayed for F1, F2, and F3.</p> <p>Notes:</p> <ul style="list-style-type: none"> <li>• Press the  Key to quit the online vibration monitor function. The display returns to the Utility Function Mode main menu.</li> <li>• Three detected frequencies can be displayed. For a vibration with undetectable peak frequency, “----” is displayed. If no frequency was detected, “----” is displayed for F1, F2, and F3.</li> <li>• If the frequency could not be successfully detected, “NO MONITOR” is displayed.</li> </ul>
5	<pre> DONE     -V-MONITOR- SETTING DONE F1= 0850 [Hz] F2= 1600 [Hz] F3= 0225 [Hz]           </pre>		<p>After the detection has normally completed, press the  Key. The optimum frequency (time constant) of notch filter or force reference filter for F1 is set automatically. At the same time, the parameter Pn409 is updated for a notch filter, or the parameter Pn401 is updated for a force reference filter.</p>
6	<pre> RUN      -FUNCTION- Fn206: Easy FFT Fn207: V-Monitor Fn000: Alm History Fn001: JOG           </pre>		<p>Press the  Key to return to the Utility Function Mode main menu.</p>

## (2) Related Parameters

The following parameters are set automatically by using online vibration monitor.

Parameter	Meaning
<b>Pn401</b>	Force Reference Filter Time Constant
<b>Pn408</b>	Force Related Function Switch
<b>Pn409</b>	1st Notch Filter Frequency

---

## Monitor Modes (Un□□□)

7.1 List of Monitor Modes .....	7-2
7.2 Monitor Displays .....	7-3

## 7.1 List of Monitor Modes

The monitor mode can be used for monitoring the reference values, I/O signal status, and SERVOPACK internal status on the digital operator.

Refer to the following table.

Parameter No.	Content of Display	Unit
Un000	Motor movement speed	mm/s
Un001	Speed reference (for speed control)	mm/s
Un002	Internal force reference (in percentage to the rated force)	%
Un003	Electric angle 1	pulse (linear scale resolution)
Un004	Electric angle 2 (angle from the polarity origin)	deg
Un005	Input signal monitor	–
Un006	Output signal monitor	–
Un007	Reference speed (for position control)	mm/s
Un008	Position error (for position control)	reference unit
Un009	Accumulated load ratio (in percentage to the rated force: effective force in cycle of 10 seconds)	%
Un00A	Regenerative load ratio (in percentage to the processable regenerative power: regenerative power consumption in cycle of 10 seconds)	%
Un00B	Power consumed by DB resistance (in percentage to the processable power at DB activation: displayed in cycle of 10 seconds)	%
Un00C	Reference counter	reference unit
Un00D	Feedback pulse counter	pulse (linear scale resolution) <sup>*1</sup>
Un010	Maximum allowable motor speed or maximum allowable encoder output resolution	–
Un011	Hall sensor signal monitor	–
Un012	Total operation time	100 ms
Un013	Feedback pulse counter	reference unit
Un014	Effective gain monitor (gain setting 1 = 1, gain setting 2 = 2)	–
Un015	Safety I/O signal monitor	–
Un020	Motor rated speed	mm/s
Un021	Motor maximum speed	mm/s
Un084	Linear scale pitch <sup>*2</sup>	pm
Un085	Linear scale pitch index <sup>*2</sup>	–

\*1. For details, refer to 4.2.4 *Electronic Gear*.

\*2. Scale pitch =  $Un084 \times 10^{Un085}$  [pm]

## 7.2 Monitor Displays

























Monitor mode can be checked in the Parameter/Monitor Mode (-PRM/MON-) window of the digital operator.

The following four Un numbers are displayed as the factory settings.

BB	-PRM/MON-
Un00 <u>0</u>	= 00000
Un00 <u>2</u>	= 00000
Un00 <u>8</u>	= 00000
Un00 <u>D</u>	= 00000000

← Indicates that the value of Un000 (motor speed) is 0 mm/s.

To view other Un numbers, press the  or  Key to scroll through the list in monitor mode.

Motor speed	Un00 <u>0</u> = 00000
	   
Speed reference	Un00 <u>1</u> = 00000
	   
Internal force reference	Un00 <u>2</u> = 00000
	   
Electric angle 1	Un00 <u>3</u> = 00000
	   
Electric angle 2 (angle from the polarity origin)	Un00 <u>4</u> = 00090
	   
	   
Feedback pulse counter	Un00 <u>D</u> = 00000000

---

## Troubleshooting

8.1 Troubleshooting .....	8-2
8.1.1 List of Alarms .....	8-2
8.1.2 Troubleshooting of Alarms .....	8-6
8.2 Warning Displays .....	8-23
8.2.1 List of Warnings .....	8-23
8.2.2 Troubleshooting of Warnings .....	8-25
8.3 Troubleshooting Malfunction Based on Operation and Conditions of the Linear Servomotor .....	8-29

## 8.1 Troubleshooting

The following sections describe troubleshooting in response to alarm displays.

The alarm name, alarm meaning, alarm stopping method, and alarm reset capability are listed in order of the alarm numbers in *8.1.1 List of Alarms*.

The causes of alarms and troubleshooting methods are provided in *8.1.2 Troubleshooting of Alarms*.

### 8.1.1 List of Alarms

The list of alarms is given below.

#### ■ Alarm Stopping Method

Gr.1: The linear servomotor is stopped according to the settings in Pn001.0 if an alarm occurs. Pn001.0 is factory-set to stop the linear servomotor by applying the DB.

Gr.2: The linear servomotor is stopped according to the setting in Pn00B.1 if an alarm occurs. Pn00B.1 is factory-set to stop the linear servomotor by setting the speed reference to "0." The linear servomotor under force control will always use the Gr.1 method to stop. By setting Pn00B.1 to 1, the linear servomotor stops using the same method as Gr.1. When coordinating a number of linear servomotors, use this alarm stop method to prevent machine damage that may result due to differences in the stop method.

#### ■ Alarm Reset Capability

Available: Removing the cause of alarm and then executing the alarm reset can clear the alarm.

N/A: Executing the alarm reset cannot clear the alarm.

Alarm Display	Alarm Name	Meaning	Servomotor Stop Method	Alarm Reset
A.020	Parameter Checksum Error	The data of the parameter in the SERVOPACK is incorrect.	Gr.1	N/A
A.021	Parameter Format Error	The data format of the parameter in the SERVOPACK is incorrect.	Gr.1	N/A
A.022	System Checksum Error	The data of the parameter in the SERVOPACK is incorrect.	Gr.1	N/A
A.030	Main Circuit Detector Error	Detection data for power circuit is incorrect.	Gr.1	Available
A.040	Parameter Setting Error	The parameter setting is outside the allowable setting range.	Gr.1	N/A
A.041	Encoder Output Pulse Setting Error	The encoder output resolution setting (Pn281) is outside the allowable setting range or does not satisfy the setting conditions.	Gr.1	N/A
A.042	Parameter Combination Error	Combination of some parameters exceeds the setting range.	Gr.1	N/A
A.044	Semi-closed/Fully-closed Loop Control Parameter Setting Error	The settings of the fully-closed option module and Pn00B.3, Pn002.3 do not match.	Gr.1	N/A
A.04A	Parameter Setting Error 2	There is an error in settings of parameters reserved by the system.	Gr.1	N/A
A.050	Combination Error	The SERVOPACK and the linear servomotor capacities do not match each other.	Gr.1	Available
A.051	Unsupported Device Alarm	The unsupported device unit was connected.	Gr.1	N/A
A.080	Linear Scale Pitch Setting Error	The setting of the linear scale pitch (Pn282) has not been changed from the default setting.	Gr.1	N/A
A.0b0	Cancelled Servo ON Command Alarm	The Servo ON command was sent from the host controller after the utility function was executed to turn the power to the linear servomotor ON.	Gr.1	Available
A.100	Overcurrent or Heat Sink Overheated	An overcurrent flowed through the IGBT. Heat sink of the SERVOPACK was overheated.	Gr.1	N/A
A.300	Regeneration Error	Regenerative circuit or regenerative resistor is faulty.	Gr.1	Available
A.320	Regenerative Overload	Regenerative energy exceeds regenerative resistor capacity.	Gr.2	Available

Alarm Display	Alarm Name	Meaning	Servomotor Stop Method	Alarm Reset
A.330	Main Circuit Power Supply Wiring Error	<ul style="list-style-type: none"> <li>Setting of AC input/DC input is incorrect.</li> <li>Power supply wiring is incorrect.</li> </ul>	Gr.1	Available
A.400	Overvoltage	Main circuit DC voltage is excessively high.	Gr.1	Available
A.410	Undervoltage	Main circuit DC voltage is excessively low.	Gr.2	Available
A.450	Main-Circuit Capacitor Overvoltage	The capacitor of the main circuit has deteriorated or is faulty.	Gr.1	N/A
A.510	Overspeed	The linear servomotor speed is over the maximum allowable speed.	Gr.1	Available
A.511	Overspeed of Encoder Output Pulse Rate	The set value of the encoder output resolution (Pn281) exceeds the speed limit.	Gr.1	Available
A.520	Vibration Alarm	Vibration at the motor speed was detected.	Gr.1	Available
A.521	Autotuning Alarm	Vibration was detected while performing tuning-less function.	Gr.1	Available
A.550	Maximum Speed Setting Error	The Pn385 setting is greater than the maximum speed.	Gr.1	Available
A.710	Overload: High Load	The linear servomotor was operating for several seconds to several tens of seconds under a force largely exceeding ratings.	Gr.2	Available
A.720	Overload: Low Load	The linear servomotor was operating continuously under a force largely exceeding ratings.	Gr.1	Available
A.730 A.731	Dynamic Brake Overload	When the dynamic brake was applied, moving energy exceeded the capacity of dynamic brake resistor.	Gr.1	Available
A.740	Overload of Surge Current Limit Resistor	The main circuit power was frequently turned ON and OFF.	Gr.1	Available
A.7A0	Heat Sink Overheated	The temperature of the SERVOPACK heat sink exceeded 100°C.	Gr.2	Available
A.7AB	Built-in Fan in SERVOPACK Stopped	The fan inside the SERVOPACK stopped.	Gr.1	Available
A.820	Encoder Checksum Error	The checksum results of linear scale memory is incorrect.	Gr.1	N/A
A.840	Encoder Data Error	Data in the linear scale is incorrect.	Gr.1	N/A
A.850	Encoder Overspeed	The linear scale was operating at high speed when the power was turned ON.	Gr.1	N/A
A.860	Encoder Overheated	The internal temperature of linear scale is too high.	Gr.1	N/A
A.890	Encoder Scale Error	A linear scale fault occurred.	Gr.1	N/A
A.891	Encoder Module Error	Linear scale is faulty.	Gr.1	N/A
A.b31	Current Detection Error 1 (Phase-U)	The current detection circuit for phase-U is faulty.	Gr.1	N/A
A.b32	Current Detection Error 2 (Phase-V)	The current detection circuit for phase-V is faulty.	Gr.1	N/A
A.b33	Current Detection Error 3 (Current detector)	The detection circuit for the current is faulty.	Gr.1	N/A
A.bF0	System Alarm 0	"Internal program error 0" occurred in the SERVOPACK.	Gr.1	N/A
A.bF1	System Alarm 1	"Internal program error 1" occurred in the SERVOPACK.	Gr.1	N/A
A.bF2	System Alarm 2	"Internal program error 2" occurred in the SERVOPACK.	Gr.1	N/A
A.bF3	System Alarm 3	"Internal program error 3" occurred in the SERVOPACK.	Gr.1	N/A
A.bF4	System Alarm 4	"Internal program error 4" occurred in the SERVOPACK.	Gr.1	N/A
A.C10	Servo Overrun Detected	The linear servomotor ran out of control.	Gr.1	Available
A.C20	Phase Detection Error	The detection of the phase is incorrect.	Gr.1	N/A
A.C21	Hall Sensor Error	The hall sensor is faulty.	Gr.1	N/A
A.C22	Phase Information Disagreement	The phase information does not match.	Gr.1	N/A
A.C50	Polarity Detection Error	The polarity detection failed.	Gr.1	N/A



## 8.1.1 List of Alarms

Alarm Display	Alarm Name	Meaning	Servomotor Stop Method	Alarm Reset
A.C51	Overtravel Detection at Polarity Detection	The overtravel signal was detected at polarity detection.	Gr.1	Available
A.C52	Polarity Detection Uncompleted	The linear servomotor was turned ON under the condition of polarity detection uncompleted.	Gr.1	Available
A.C53	Out of Range for Polarity Detection	The movement distance exceeded the set value of Pn48E during polarity detection.	Gr.1	N/A
A.C54	Polarity Detection Error 2	The polarity detection failed.	Gr.1	N/A
A.C80	Absolute Encoder Clear Error	The data of the absolute linear scale was not properly cleared or set.	Gr.1	N/A
A.C90	Encoder Communications Error	Communications between the SERVOPACK and the linear scale is not possible.	Gr.1	N/A
A.C91	Encoder Communications Position Data Error	A linear scale position data calculation error occurred.	Gr.1	N/A
A.C92	Encoder Communications Timer Error	An error occurs in the communications timer between the linear scale and the SERVOPACK.	Gr.1	N/A
A.CA0	Encoder Parameter Error	Linear scale parameters are faulty.	Gr.1	N/A
A.Cb0	Encoder Echoback Error	Contents of communications with linear scale is incorrect.	Gr.1	N/A
A.CF1	Feedback Option Module Communications Error (Reception error)	Reception from the feedback option module is faulty.	Gr.1	N/A
A.CF2	Feedback Option Module Communications Error (Timer stop)	Timer for communications with the feedback option module is faulty.	Gr.1	N/A
A.d00	Position Error Pulse Overflow	Position error pulses exceeded the value set for parameter (Pn520) (Excessive Position Error Alarm Level).	Gr.1	Available
A.d01	Position Error Pulse Overflow Alarm at Servo ON	Position error pulses accumulated too much.	Gr.1	Available
A.d02	Position Error Pulse Overflow Alarm by Speed Limit at Servo ON	After a position error pulse has been input, Pn584 limits the speed if the servo ON command is received. If Pn584 limits the speed in such a state, this alarm occurs when the position references are input and the number of position error pulses exceeds the value set for parameter Pn520 (Excessive Position Error Alarm Level).	Gr.2	Available
A.d30	Position Data Overflow	The position feedback data exceeded $\pm 1879048192$ .	Gr.1	N/A
A.E00	Command Option Module IF Initialization Timeout Error	Communications initialization failed between the SERVOPACK and the command option module.	Gr.2	Available
A.E02	Command Option Module IF Synchronization Error 1	A synchronization error occurred between the SERVOPACK and the command option module.	Gr.1	Available
A.E03	Command Option Module IF Communications Data Error	An error occurred in the data of communications between the SERVOPACK and the command option module.	Gr.1	Available
A.E40	Command Option Module IF Communications Setting Error	An error occurred in establishing communications (settings) between the SERVOPACK and the command option module.	Gr.2	Available
A.E50	Command Option Module IF Synchronization Error 2	A error occurred in synchronization between the SERVOPACK and the command option module.	Gr.2	Available
A.E51	Command Option Module IF Synchronization Establishment Error	A error occurred in establishing communications between the SERVOPACK and the command option module.	Gr.2	Available
A.E60	Command Option Module IF Data Communications Error	A error occurred in communications between the SERVOPACK and the command option module.	Gr.2	Available
A.E61	Command Option Module IF Synchronization Error 3	There was a change in timing of synchronization between the SERVOPACK and the command option module.	Gr.2	Available
A.E70	Command Option Module Detection Failure	Detection of the command option module failed.	Gr.1	N/A
A.E71	Safety Option Module Detection Failure	Detection of the safety option module failed.	Gr.1	N/A

Alarm Display	Alarm Name	Meaning	Servomotor Stop Method	Alarm Reset
<b>A.E72</b>	Feedback Option Module Detection Failure	Detection of the feedback option module failed.	Gr.1	N/A
<b>A.E73</b>	Unsupported Command Option Module	An unsupported command option module was connected.	Gr.1	N/A
<b>A.E74</b>	Unsupported Safety Option Module	An unsupported safety option module was connected.	Gr.1	N/A
<b>A.E75</b>	Unsupported Feedback Option Module	An unsupported feedback option module was connected.	Gr.1	N/A
<b>A.E80</b>	Command Option Module Unmatched Error	The command option module was replaced with a different model.	Gr.1	N/A
<b>A.EA2</b>	DRV Alarm 2 (SERVOPACK WDC error)	A DRV 0 error of the SERVOPACK occurred.	Gr.2	Available
<b>A.Eb1</b>	Safety Device Signal Input Timing Error	There is an error in the timing of the safety function input signal.	Gr.1	N/A
<b>A.ED1</b>	Command Option Module IF Command Timeout Error	Processing of reference from the command option module was not completed.	Gr.2	Available
<b>A.F10</b>	Main Circuit Cable Open Phase	With the main power supply ON, voltage was low for more than 1 second in phase-R, -S or -T.	Gr.2	Available
<b>CPF00</b>	Digital Operator Transmission Error 1	Digital operator (JUSP-OP05A) fails to communicate with the SERVOPACK (e.g., CPU error).	–	N/A
<b>CPF01</b>	Digital Operator Transmission Error 2		–	N/A
<b>A.--</b>	Not an error	Normal operation status	–	–

## 8.1.2 Troubleshooting of Alarms

When an error occurs in SERVOPACKs, an alarm is displayed such as A.□□□ and CPF□□ on the panel operator. Refer to the following table to identify the cause of an alarm and the action to be taken.

Contact your Yaskawa representative if the problem cannot be solved by the described corrective action.

Alarm: Alarm Name	Cause	Investigative Actions	Corrective Actions
A.020: Parameter Checksum Error (The parameter data in the SERVOPACK is incorrect.)	The power supply voltage suddenly dropped.	Measure the power supply voltage.	Set the power supply voltage within the specified range, and initialize the parameter (Fn005).
	The power supply went OFF while changing a parameter setting.	Note the circumstances when the power supply went OFF.	Initialize the parameter (Fn005) and then set the parameter again.
	The number of times that parameters were written exceeded the limit.	Were the parameters frequently changed through the host controller?	The SERVOPACK may be faulty. Repair or replace the SERVOPACK. Reconsider the method of writing parameters.
	Malfunction caused by noise from the AC power supply or grounding line, static electricity noise, etc.	Turn the power supply ON and OFF several times. If the alarm still occurs, there may be noise interference.	Take countermeasures against noise.
	Gas, water drops, or cutting oil entered the SERVOPACK and caused failure of the internal components.	Check the installation conditions.	The SERVOPACK may be faulty. Replace the SERVOPACK.
	A SERVOPACK fault occurred.	Turn the power supply ON and OFF several times. If the alarm still occurs, the SERVOPACK is faulty.	The SERVOPACK may be faulty. Replace the SERVOPACK.
A.021: Parameter Format Error (The parameter data format in the SERVOPACK is incorrect.)	The software version of SERVOPACK that caused the alarm is older than that of the written parameter.	Check Fn012 to see if the set software version agrees with that of the SERVOPACK. If not, an alarm may occur.	Write the parameter of another SERVOPACK of the same model with the same software version. Then turn the power OFF and then ON again.
	A SERVOPACK fault occurred.	—	The SERVOPACK may be faulty. Replace the SERVOPACK.
A.022: System Checksum Error (The parameter data in the SERVOPACK is incorrect.)	The power supply voltage suddenly dropped.	Measure the power supply voltage.	The SERVOPACK may be faulty. Replace the SERVOPACK.
	The power supply went OFF while setting an utility function.	Note the circumstances when the power supply went OFF.	The SERVOPACK may be faulty. Replace the SERVOPACK.
	A SERVOPACK fault occurred.	Turn the power supply ON and OFF several times. If the alarm still occurs, the SERVOPACK is faulty.	The SERVOPACK may be faulty. Replace the SERVOPACK.
A.030: Main Circuit Detector Error	A SERVOPACK fault occurred.	—	The SERVOPACK may be faulty. Replace the SERVOPACK.
A.040: Parameter Setting Error (The parameter setting was out of the allowable setting range.)	The SERVOPACK and linear servomotor capacities do not match each other.	Check the combination of SERVOPACK and linear servomotor capacities.	Select the proper combination of SERVOPACK and linear servomotor capacities.
	A SERVOPACK fault occurred.	—	The SERVOPACK may be faulty. Replace the SERVOPACK.
	The parameter setting is out of the specified range.	Check the setting ranges of the parameters that have been changed.	Set the parameter to a value within the specified range.
	The electronics gear ratio is out of the setting range.	Check the electronic gear ratio. The ratio must satisfy: $0.001 < (Pn20E/Pn210) < 4000$ .	Set the electronic gear ratio in the range: $0.001 < (Pn20E/Pn210) < 4000$ .
A.041: Encoder Output Pulse Setting Error	The encoder output resolution (Pn281) is out of the setting range and does not satisfy the setting conditions.	Check the parameter Pn281.	Set Pn281 to a correct value.

Alarm: Alarm Name	Cause	Investigative Actions	Corrective Actions
A.042: Parameter Combination Error	The speed of program JOG operation (Fn004) is lower than the setting range after having changed the electronic gear ratio (Pn20E/Pn210) or the linear servomotor.	Check if the detection conditions* are satisfied.	Reduce the electronic gear ratio (Pn20E/Pn210).
	The speed of program JOG operation (Fn004) is lower than the setting range after having changed the setting of Pn585 "Program JOG Movement Speed."	Check if the detection conditions* are satisfied.	Increase the setting for Pn585 "Program JOG Movement Speed."
	The movement speed during advanced autotuning is lower than the setting range after having changed the electronic gear ratio (Pn20E/Pn210) or the linear servomotor.	Check if the detection conditions* are satisfied.	Reduce the electronic gear ratio (Pn20E/Pn210).
A.044: Semi-closed/Fully-closed Loop Control Parameter Setting Error	The setting of the option module does not match with that of Pn002.3.	Check the settings of Pn002.3.	The setting of option module must be compatible with the settings of Pn002.3.
A.04A: Parameter Setting Error 2	A parameter reserved by the system was changed.	—	Set the following reserved parameters to the factory settings. Pn200.2 Pn207.1 Pn50A.0 Pn50A.1 Pn50A.2 Pn50C Pn50D
A.050: Combination Error (The SERVOPACK and servomotor capacities do not correspond.)	The SERVOPACK and linear servomotor capacities do not match each other.	Check the capacities if they satisfy the following equation: $1/4 \leq (\text{Linear servomotor capacity}) / (\text{SERVOPACK capacity}) \leq 4$ .	Select the proper combination of SERVOPACK and linear servomotor capacities.
	A linear scale fault occurred.	Replace the linear servomotor and see if the alarm occurs again.	Replace the linear servomotor (linear scale).
	A SERVOPACK fault occurred.	—	The SERVOPACK may be faulty. Replace the SERVOPACK.

\* Detection conditions

If one of the following conditions is detected, an alarm occurs.

- $\frac{\text{Pn585}[\text{mm/s}]}{\text{Linear scale pitch} [\mu\text{m}]} \times \frac{\text{Number of divisions of serial converter unit}}{10} \leq \frac{\text{Pn20E}}{\text{Pn210}}$
- $\frac{\text{Pn385} [100 \text{ mm/s}]}{\text{Linear scale pitch} [\mu\text{m}]} \times \frac{\text{Number of divisions of serial converter unit}}{\text{About } 6.10 \times 10^5} \geq \frac{\text{Pn20E}}{\text{Pn210}}$

Alarm: Alarm Name	Cause	Investigative Actions	Corrective Actions
A.051: Unsupported Device Alarm	An unsupported serial converter unit or linear scale is connected to the SERVOPACK.	Check the product specifications.	Select the correct combination of units.
A.080: Linear Scale Pitch Setting Error	The setting of the linear scale pitch (Pn282) has not been changed from the default setting.	Check the value of Pn282.	Correct the value of Pn282.
A.0b0: Cancelled Servo ON Command Alarm	After executing the utility function to turn ON the power to the servomotor, the Servo ON command was sent from the host controller.	–	Turn the SERVOPACK power supply OFF and then ON.
A.100: Overcurrent or Heat Sink Overheated (An overcurrent flowed through the IGBT or heat sink of SERVOPACK overheated.)	Incorrect wiring or contact fault of main circuit cable or motor main circuit cable.	Check the wiring. Refer to 3.1 <i>Main Circuit Wiring</i> .	Correct the wiring.
	Short-circuit or ground fault of main circuit cable or linear servomotor main circuit cable.	Check for short-circuits across the linear servomotor terminal phase-U, -V, and -W, or between the grounding and linear servomotor terminal U, V, or W. Refer to 3.1 <i>Main Circuit Wiring</i> .	Some cables may be damaged. Replace damaged cables.
	Short-circuit or ground fault inside the linear servomotor.	Check for short-circuits across the linear servomotor terminal phase-U, -V, and -W, or between the grounding and linear servomotor terminal U, V, or W. Refer to 3.1 <i>Main Circuit Wiring</i> .	The linear servomotor may be faulty. Replace the linear servomotor.
	Short-circuit or ground fault inside the SERVOPACK.	Check for short-circuits across the linear servomotor connection terminals U, V, and W on the SERVOPACK, or between the grounding and terminal U, V, or W. Refer to 3.1 <i>Main Circuit Wiring</i> .	The SERVOPACK may be faulty. Replace the SERVOPACK.
	Incorrect wiring or contact fault of the regenerative resistor.	Check the wiring. Refer to 3.7 <i>Regenerative Resistors Connections</i> .	Correct the wiring.
	The dynamic brake (DB: Emergency stop executed from the SERVOPACK) was frequently activated, or the DB overload alarm occurred.	Check the resistor power consumption monitor Un00B to see how many times the DB has been used. Or, check the alarm history Fn000 to see if the DB overload alarm A.730 or A.731 was reported.	Change the SERVOPACK model, operation conditions, or the mechanism so that the DB does not need to be used so frequently.
	The generated regenerative energy exceeded the SERVOPACK regenerative energy processing capacity.	Check the regenerative load ratio monitor Un00A to see how many times the regenerative resistor has been used.	Check the operation condition including overload, and reconsider the regenerative resistor value.
	The SERVOPACK regenerative resistance is too small.	Check the regenerative load ratio Un00A to see how many times the regenerative resistor has been used.	Change the regenerative resistance value to a value larger than the SERVOPACK minimum allowable resistance value.
	A heavy load was applied while the linear servomotor was stopped or running at low speed.	Check to see if the operating conditions are outside servo drive specifications.	Reduce the load applied to the linear servomotor or increase the operation speed.
	Malfunction caused by noise interference.	Improve the wiring or installation environment, such as by reducing noise, and check to see if the alarm recurs.	Take countermeasures for noise, such as correct wiring of the FG. Use an FG wire size equivalent to the SERVOPACK main circuit wire size.
A SERVOPACK fault occurred.	–	Turn the power supply OFF and then ON again. If the alarm still occurs, the SERVOPACK may be faulty. Replace the SERVOPACK.	

Alarm: Alarm Name	Cause	Investigative Actions	Corrective Actions
A.300: Regeneration Error	Regenerative resistor capacity (Pn600) is set to a value other than 0 for a SGDVR70, -R90, -1R6, or -2R8 SERVOPACK, and an external regenerative resistor is not connected.	Check the external regenerative resistor connection and the value of the Pn600.	Connect the external regenerative resistor, or set Pn600 to 0 if no regenerative resistor is required.
	The jumper between the power supply terminals B2 and B3 is removed.	Confirm that a jumper is mounted between the power supply terminals B2 and B3.	Correctly mount a jumper.
	The external regenerative resistor is incorrectly wired, or is removed or disconnected.	Check the external regenerative resistor connection.	Correctly connect the external regenerative resistor.
	A SERVOPACK fault occurred.	–	While the main circuit power supply is OFF, turn the control power supply OFF and then turn ON again. If the alarm still occurs, the SERVOPACK may be faulty. Replace the SERVOPACK.
A.320: Regenerative Overload	The power supply voltage exceeds the specified limit.	Measure the power supply voltage.	Set the power supply voltage within the specified range.
	Incorrect external regenerative resistance. Insufficient SERVOPACK capacity or regenerative resistor capacity. Or, regenerative power has been continuously flowing back.	Check the operation condition or the capacity using the capacity selection Software SigmaJunma-Size+, etc.	Change the regenerative resistance, regenerative resistor capacity, or SERVOPACK capacity. Reconsider the operation conditions using the capacity selection software SigmaJunmaSize+, etc.
	Regenerative power continuously flowed back because negative load was continuously applied.	Check the load to the linear servomotor during operation.	Reconsider the system including servo, machine, and operation conditions.
	The setting of parameter Pn600 is smaller than the external regenerative resistor's capacity.	Check the external regenerative resistor connection and the value of the Pn600.	Set the Pn600 to a correct value.
	The external regenerative resistance is too high.	Check the regenerative resistance.	Change the regenerative resistance to a correct value or use an external regenerative resistor of appropriate capacity.
	A SERVOPACK fault occurred.	–	The SERVOPACK may be faulty. Replace the SERVOPACK.
	A.330: Main Circuit Power Supply Wiring Error (Detected when the power to the main circuit is turned ON.)	The regenerative resistor disconnected when the SERVOPACK power voltage was increased.	Measure the resistance of the regenerative resistor.
In the AC power input mode, DC power was supplied.		Check the power supply to see if it is a DC power supply.	Correct the settings to match the actual power supply specifications.
In the DC power input mode, AC power was supplied.		Check the power supply to see if it is a AC power supply.	Correct the settings to match the actual power supply specifications.
Regenerative resistor capacity (Pn600) is not set to 0 even though the regenerative resistor is disconnected.		Is the regenerative resistor connected? If it is, check the regenerative resistor capacity.	Set Pn600 to 0.
A SERVOPACK fault occurred.		–	The SERVOPACK may be faulty. Replace the SERVOPACK.

Alarm: Alarm Name	Cause	Investigative Actions	Corrective Actions
A.400: Overvoltage (Detected in the SERVOPACK's main circuit power supply section.)	<ul style="list-style-type: none"> <li>For 100 VAC SERVOPACKs: The AC power supply voltage exceeded 145 V.</li> <li>For 200 VAC SERVOPACKs: The AC power supply voltage exceeded 290 V.</li> <li>For 400 VAC SERVOPACKs: The AC power supply voltage exceeded 580 V.</li> <li>For 200 VAC SERVOPACKs with DC power supply input: The power supply voltage exceeded 410 V.</li> <li>For 400 VAC SERVOPACKs with DC power supply input: The power supply voltage exceeded 820 V.</li> </ul>	Measure the power supply voltage.	Set AC/DC power supply voltage within the specified range.
	The power supply is unstable, or was influenced by a lightning surge.	Measure the power supply voltage.	Improve the power supply conditions by installing a surge absorber, etc. Then, turn the power supply ON again. If the alarm still occurs, the SERVOPACK may be faulty. Replace the SERVOPACK.
	Acceleration/deceleration was executed under the following conditions. <ul style="list-style-type: none"> <li>The AC power supply voltage of 100 VAC SERVOPACK was in the range between 115 V and 135 V.</li> <li>The AC power supply voltage of 200 VAC SERVOPACK was in the range between 230 V and 270 V.</li> <li>The AC power supply voltage of 400 VAC SERVOPACK was in the range between 480 V and 560 V.</li> </ul>	Check the power supply voltage and the speed and force during operation.	Set AC power supply voltage within the specified range.
	The external regenerative resistance is too high for the actual operation conditions.	Check the operation conditions and the regenerative resistance.	Select a regenerative resistance value appropriate for the operation conditions and load.
	The mass exceeded the allowable value.	Confirm that the mass ratio is within the allowable load.	Increase the deceleration time, or reduce the load.
	A SERVOPACK fault occurred.	—	Turn the control power OFF and then ON again while the main circuit power supply is OFF. If the alarm still occurs, the SERVOPACK may be faulty. Replace the SERVOPACK.

Alarm: Alarm Name	Cause	Investigative Actions	Corrective Actions
A.410: Undervoltage (Detected in the SERVOPACK main circuit power supply section.)	<ul style="list-style-type: none"> <li>For 100 VAC SERVOPACKs: The power supply voltage is 49 V or less.</li> <li>For 200 VAC SERVOPACKs: The power supply voltage is 120 V or less.</li> <li>For 400 VAC SERVOPACKs: The power supply voltage is 240 V or less.</li> </ul>	Measure the power supply voltage.	Set the power supply voltage within the specified range.
	The power supply voltage dropped during operation.	Measure the power supply voltage.	Increase the power supply capacity.
	Occurrence of instantaneous power interruption.	Measure the power supply voltage.	When the instantaneous power cut hold time Pn509 is set, decrease the setting.
	The SERVOPACK fuse is blown out.	–	Replace the SERVOPACK, connect an AC/DC reactor, and run the SERVOPACK.
	A SERVOPACK fault occurred.	–	The SERVOPACK may be faulty. Replace the SERVOPACK.
A.450: Main-Circuit Capacitor Overvoltage	A SERVOPACK fault occurred.	–	Replace the SERVOPACK.
A.510: Overspeed (The servomotor speed exceeds the maximum.)	The order of phases U, V, and W in the linear servomotor wiring is incorrect.	Check the linear servomotor wiring.	Confirm that the linear servomotor is correctly wired.
	A reference value exceeding the overspeed detection level was input.	Check the input value.	Reduce the reference value or adjust the gain.
	The motor speed exceeded the maximum.	Check the linear servomotor speed waveform.	Reduce the speed reference input gain, adjust the servo gain, or reconsider the operation conditions.
	A SERVOPACK fault occurred.	–	The SERVOPACK may be faulty. Replace the SERVOPACK.
A.511: Overspeed of Encoder Output Pulse Rate	The encoder output pulse output frequency exceeded the limit.	Check the encoder output pulse output setting.	Decrease the setting of the encoder output resolution (Pn281).
	The encoder output pulse output frequency exceeded the limit because the motor speed was too high.	Check the encoder output pulse output setting and the motor speed.	Decrease the motor speed.
A.520: Vibration Alarm	Abnormal vibration was detected at the motor speed.	Check for abnormal noise from the linear servomotor, and check the speed and force waveform during operation.	Reduce the motor speed or reduce the speed loop gain (Pn100).
	The mass ratio (Pn103) value is greater than the actual value or is greatly changed.	Check the mass ratio.	Set the mass ratio (Pn103) to an appropriate value.
A.521: Autotuning Alarm (Vibration was detected while executing the advanced autotuning, one-parameter tuning, EasyFFT, or tuning-less function.)	The linear servomotor vibrated considerably while performing tuning-less function (factory setting).	Check the motor speed waveform.	Reduce the load so that the mass ratio falls within the allowable value, or raise the tuning level or reduce the gain level using the tuning-less function (Fn200).
	The linear servomotor vibrated considerably during advanced autotuning, one-parameter tuning, or EasyFFT.	Check the motor speed waveform.	Check the operation procedure of corresponding function and take a corrective action.



## 8.1.2 Troubleshooting of Alarms

Alarm: Alarm Name	Cause	Investigative Actions	Corrective Actions
A.550: Maximum Speed Setting Error	The Pn385 setting is greater than the maximum speed.	Check the value of Pn385 and Un010 (maximum allowable motor speed or maximum allowable encoder output resolution).	Set Pn385 to a value equal to or lower than the motor maximum speed.
A.710: A.720: Overload A.710: High Load A.720: Low Load	Incorrect wiring or contact fault of linear servomotor and linear scale.	Check the wiring.	Confirm that the linear servomotor and linear scale are correctly wired.
	Operation beyond the overload protection characteristics.	Check the linear servomotor overload characteristics and executed run command.	Reconsider the load conditions and operation conditions. Or, increase the linear servomotor capacity.
	Excessive load was applied during operation because the linear servomotor was not driven due to mechanical problems.	Check the executed run command and linear servomotor speed.	Remove the mechanical problems.
	The setting of the linear scale pitch (Pn282) is incorrect.	Check the setting of Pn282.	Correct the setting of Pn282.
	The setting of the motor phase selection (Pn080.1) is incorrect.	Check the setting of Pn080.1.	Correct the setting of Pn080.1.
	A SERVOPACK fault occurred.	–	The SERVOPACK may be faulty. Replace the SERVOPACK.
A.730: A.731: Dynamic Brake Overload (An excessive power consumption of dynamic brake was detected.)	The linear servomotor moves because of external force.	Check the operation status.	Take measures to ensure the linear servomotor will not move because of external force.
	The moving energy at a DB stop exceeds the DB resistance capacity.	Check the DB resistor power consumption (Un00B) to see how many times the DB has been used.	<ul style="list-style-type: none"> <li>• Reduce the linear servomotor reference speed.</li> <li>• Reduce the mass ratio.</li> <li>• Reduce the number of times of the DB stop operation.</li> </ul>
	A SERVOPACK fault occurred.	–	The SERVOPACK may be faulty. Replace the SERVOPACK.
A.740: Overload of Surge Current Limit Resistor (The main circuit power is turned ON/OFF too frequently.)	The inrush current limit resistor operation frequency at the main circuit power supply ON/OFF operation exceeds the allowable range.	–	Reduce the frequency of turning the main circuit power supply ON/OFF.
	A SERVOPACK fault occurred.	–	The SERVOPACK may be faulty. Replace the SERVOPACK.
A.7A0: Heat Sink Overheated (Detected when the heat sink temperature exceeds 100°C.)	The surrounding air temperature is too high.	Check the surrounding air temperature using a thermostat.	Decrease the surrounding air temperature by improving the SERVOPACK installation conditions.
	The overload alarm has been reset by turning OFF the power too many times.	Check the alarm history display (Fn000) to see if the overload alarm was reported.	Change the method for resetting the alarm.
	Excessive load or operation beyond the regenerative energy processing capacity.	Check the accumulated load ratio (Un009) to see the load during operation, and the regenerative load ratio (Un00A) to see the regenerative energy processing capacity.	Reconsider the load and operation conditions.
	Incorrect SERVOPACK installation orientation or/and insufficient space around the SERVOPACK.	Check the SERVOPACK installation conditions.	Install the SERVOPACK correctly as specified.
	A SERVOPACK fault occurred.	–	The SERVOPACK may be faulty. Replace the SERVOPACK.
A.7AB: Built-in Fan in SERVOPACK Stopped	The fan inside the SERVOPACK stopped.	Check for foreign matter or debris inside the SERVOPACK.	Remove foreign matter or debris from the SERVOPACK. If the alarm still occurs, the SERVOPACK may be faulty. Replace the SERVOPACK.

Alarm: Alarm Name	Cause	Investigative Actions	Corrective Actions
A.820: Encoder Checksum Error (Detected on the linear scale side.)	A linear scale fault occurred.	—	The linear scale may be faulty. Replace the linear scale.
	A SERVOPACK fault occurred.	—	The SERVOPACK may be faulty. Replace the SERVOPACK.
A.840: Encoder Data Error (Detected on the linear scale side.)	A linear scale fault occurred.	—	Turn the power supply OFF and then ON again. If the alarm still occurs, the linear scale may be faulty. Replace the linear scale.
	Malfunction of linear scale because of noise interference, etc.	—	Correct the wiring around the linear scale by separating the cable for linear scale from the linear servomotor main circuit cable or by checking the grounding and other wiring.
A.850: Encoder Overspeed (Detected when the control power supply was turned ON.) (Detected on the linear scale side.)	The motor speed was higher than the specified speed when the control power supply was turned ON.	Check the motor speed (Un000) to confirm the motor speed when the power is turned ON.	Reduce the motor speed to a value below the speed specified by the linear scale manufacturer, and turn ON the control power supply.
	A linear scale fault occurred.	—	Turn the power supply OFF and then ON again. If the alarm still occurs, the linear servomotor may be faulty. Replace the linear servomotor.
	A SERVOPACK fault occurred.	—	Turn the power supply OFF and then ON again. If the alarm still occurs, the SERVOPACK may be faulty. Replace the SERVOPACK.
A.860: Encoder Overheated (Detected only when an absolute linear scale is connected.) (Detected on the linear scale side.)	The ambient operating temperature of the linear servomotor is too high.	Measure the ambient operating temperature of the linear servomotor.	The ambient operating temperature of the linear servomotor must be 40°C or less.
	The linear servomotor load is greater than the rated load.	Check the accumulated load ratio (Un009) to see the load.	The linear servomotor load must be within the specified range.
	A linear scale fault occurred.	—	Turn the power supply OFF and then ON again. If the alarm still occurs, the linear servomotor may be faulty. Replace the linear servomotor.
	A SERVOPACK fault occurred.	—	Turn the power supply OFF and then ON again. If the alarm still occurs, the SERVOPACK may be faulty. Replace the SERVOPACK.
A.890: Encoder Scale Error	A linear scale fault occurred.	—	The linear scale may be faulty. Replace the linear scale.
A.891: Encoder Module Error	A linear scale fault occurred.	—	Turn the power supply OFF and then ON again. If the alarm still occurs, the linear servomotor may be faulty. Replace the linear servomotor.
A.b31: Current Detection Error 1 (Phase-U)	The current detection circuit for phase U is faulty.	—	Turn the power supply OFF and then ON again. If the alarm still occurs, the SERVOPACK may be faulty. Replace the SERVOPACK.
A.b32: Current Detection Error 2 (Phase-V)	The current detection circuit for phase V is faulty.	—	Turn the power supply OFF and then ON again. If the alarm still occurs, the SERVOPACK may be faulty. Replace the SERVOPACK.

Alarm: Alarm Name	Cause	Investigative Actions	Corrective Actions
A.b33: Current Detection Error 3 (Current detector)	The detection circuit for the current is faulty.	—	Turn the power supply OFF and then ON again. If the alarm still occurs, the SERVOPACK may be faulty. Replace the SERVOPACK.
	The linear servomotor main circuit cable is disconnected.	Check for disconnection of the linear servomotor main circuit cable.	Correct the linear servomotor wiring.
A.bF0: System Alarm 0	A SERVOPACK fault occurred.	—	Turn the power supply OFF and then ON again. If the alarm still occurs, the SERVOPACK may be faulty. Replace the SERVOPACK.
A.bF1: System Alarm 1	A SERVOPACK fault occurred.	—	Turn the power supply OFF and then ON again. If the alarm still occurs, the SERVOPACK may be faulty. Replace the SERVOPACK.
A.bF2: System Alarm 2	A SERVOPACK fault occurred.	—	Turn the power supply OFF and then ON again. If the alarm still occurs, the SERVOPACK may be faulty. Replace the SERVOPACK.
A.bF3: System Alarm 3	A SERVOPACK fault occurred.	—	Turn the power supply OFF and then ON again. If the alarm still occurs, the SERVOPACK may be faulty. Replace the SERVOPACK.
A.bF4: System Alarm 4	A SERVOPACK fault occurred.	—	Turn the power supply OFF and then ON again. If the alarm still occurs, the SERVOPACK may be faulty. Replace the SERVOPACK.
A.C10: Servo Overrun Detected (Detected when the servomotor power is ON.)	The order of phases U, V, and W in the linear servomotor wiring is incorrect.	Check the linear servomotor wiring.	Confirm that the linear servomotor is correctly wired.
	The setting of the motor phase selection (Pn080.1) is incorrect.	Check the setting of Pn080.1.	Correct the setting of Pn080.1.
	A linear scale fault occurred.	—	If the alarm still occurs after turning the power OFF and then ON again, even though the linear servomotor is correctly wired, the linear servomotor may be faulty. Replace the linear servomotor.
	A SERVOPACK fault occurred.	—	Turn the power supply OFF and then ON again. If the alarm still occurs, the SERVOPACK may be faulty. Replace the SERVOPACK.
A.C20: Phase Detection Error	The linear scale signal is weak.	Check the voltage of the linear scale signal.	Fine-adjust the installation status of the linear scale head, or replace the linear scale.
	The count-up direction of the linear scale does not match the forward direction of the motor moving coil.	Check the setting of Pn080.1 (Motor Phase Selection). Check the installation directions for the linear scale and motor moving coil.	Change the setting of Pn080.1 (Motor Phase Selection). Correctly reinstall the linear scale and motor moving coil.
	The hall sensor signal is affected by noise.	—	Correct the FG wiring and take measures against noise for the hall sensor wiring.
A.C21: Hall Sensor Error	The hall sensor is protruding from the motor magnetic way.	Check the hall sensor.	Correctly reinstall the motor moving coil or motor magnetic way.
	The setting of the linear scale pitch (Pn282) is incorrect.	Check the setting of the linear scale pitch (Pn282).	Correct the value of Pn282.
	The hall sensor wiring is incorrect.	Check the hall sensor wiring.	Correct the hall sensor wiring.
	A hall sensor fault occurred.	—	Replace the hall sensor.

Alarm: Alarm Name	Cause	Investigative Actions	Corrective Actions
A.C22: Phase Information Disagreement	The SERVOPACK phase data does not match that of the linear scale.	—	Execute polarity detection (Fn080).
A.C50: Polarity Detection Error	Parameter settings are incorrect.	Check the linear scale specifications and feedback signal status.	The settings of the linear scale pitch (Pn282) and motor phase selection (Pn080.1) may not match the actual product requirements. Set these parameters to the correct values.
	Noise interference occurred on the scale signal.	Check the wiring to see if: <ul style="list-style-type: none"> <li>• Each FG of the serial converter unit and linear servomotor is connected to the FG of the SERVOPACK.</li> <li>• The FG of the SERVOPACK is connected to the FG of the power supply.</li> <li>• The linear scale connection cables are securely shielded.</li> </ul> Check to see if the detection reference is repeatedly output in one direction.	Take measures to avoid noise interference by correctly connecting FG lines, shielding the linear scale connection cables, etc.
	An external force was applied to the motor moving coil.	—	The polarity cannot be properly detected if the detection reference is 0 (zero), but the speed feedback is not 0 (zero) because of an external force, such as cable tension, applied to the motor moving coil. Take measures to reduce the external force so that the speed feedback becomes 0 for a 0 detection reference. If external force cannot be reduced, increase the polarity detection speed loop gain (Pn481).
	The linear scale resolution is too low.	Check the linear scale pitch to see if it is within 100 $\mu\text{m}$ .	If the linear scale pitch is 100 $\mu\text{m}$ or longer, the SERVOPACK cannot detect the correct speed feedback. Use a scale pitch with higher accuracy (a pitch within 40 $\mu\text{m}$ recommended.) Or, increase the value of the polarity detection reference speed (Pn485). However, note that increasing the value of Pn485 will widen the linear servomotor movement range required for polarity detection.
A.C51: Overtravel Detection at Polarity Detection	An overtravel signal was detected during polarity detection.	Check the position after overtravel.	Perform the wiring for an overtravel signal. Execute polarity detection at a position where an overtravel signal is not detected.
A.C52: Polarity Detection Uncompleted	The servo has been turned ON under the following circumstances. <ul style="list-style-type: none"> <li>• An absolute linear scale is being used.</li> <li>• The polarity detection selection for the absolute linear scale was set to not execute. (Pn587.0 = 0)</li> <li>• Polarity was not yet detected.</li> </ul>	—	When using an absolute linear scale, set the parameter Pn587.0 to 1 to execute polarity detection.
A.C53: Out of Range for Polarity Detection	The movement distance exceeded the set value of Pn48E in the middle of detection.	—	Increase the value of the polarity detection range (Pn48E). Or, increase the polarity detection speed loop gain (Pn481).

## 8.1.2 Troubleshooting of Alarms

Alarm: Alarm Name	Cause	Investigative Actions	Corrective Actions
A.C54: Polarity Detection Error 2	External force was applied to the linear servomotor.	—	Increase the value of the polarity detection confirmation force reference (Pn495). Increase the value of the polarity detection allowable error range (Pn498). (Note that increasing the allowable error range will also increase the motor temperature.)
A.C80: Absolute Encoder Clear Error	A linear scale fault occurred.	—	Turn the power supply OFF and then ON again. If the alarm still occurs, the linear servomotor may be faulty. Replace the linear servomotor.
	A SERVOPACK fault occurred.	—	Turn the power supply OFF and then ON again. If the alarm still occurs, the SERVOPACK may be faulty. Replace the SERVOPACK.
A.C90: Encoder Communications Error	Contact fault of cable connector for linear scale or incorrect wiring.	Check the status of cable connector contact for linear scale.	Re-insert the cable connectors for linear scale and confirm that the linear scale is correctly wired.
	Disconnection or short-circuit of the cable for linear scale. Or, incorrect cable impedance.	Check the linear scale connection cables.	Use the linear scale connection cables with the specified rating.
	<ul style="list-style-type: none"> <li>• Corrosion caused by improper temperature, humidity, or gas.</li> <li>• Short-circuit caused by intrusion of water drops or cutting oil.</li> <li>• Connector contact fault caused by vibration.</li> </ul>	Check the operating environment.	Improve the operating environmental conditions, and replace the cable. If the alarm still occurs, replace the SERVOPACK.
	Malfunction caused by noise interference.	—	Correct the wiring around the linear scale to avoid noise interference (Separate the linear scale connection cables from the linear servomotor main circuit cable, improve grounding, etc.)
	A SERVOPACK fault occurred.	—	Connect the linear servomotor to another SERVOPACK, and turn ON the control power. If no alarm occurs, the SERVOPACK may be faulty. Replace the SERVOPACK.
A.C91: Encoder Communications Position Data Error	The noise interference occurred on the input/output signal line because the linear scale connection cables are bent and the sheath is damaged.	Check the cables and connectors for linear scale.	Confirm that there is no problem with the layout of the linear scale connection cables.
	The linear scale connection cables are bundled with a high-current line or near a high-current line.	Check the layout of the linear scale connection cables.	Confirm that there is no surge voltage on the linear scale connection cables.
	The FG potential varies because of influence from machines on the servomotor side, such as the welder.	Check the layout of the linear scale connection cables.	Properly ground the device to separate from the linear scale side FG.

Alarm: Alarm Name	Cause	Investigative Actions	Corrective Actions
A.C92: Encoder Communications Timer Error	Noise interference occurred on the input/output signal line from the linear scale.	–	Take countermeasures against noise.
	Excessive vibration and shocks were applied to the linear scale.	Check the operating environment.	Reduce the machine vibration or correctly install the linear servomotor.
	A linear scale fault occurred.	–	Turn the power supply OFF and then ON again. If the alarm still occurs, the linear servomotor may be faulty. Replace the linear servomotor.
	A SERVOPACK fault occurred.	–	Turn the power supply OFF and then ON again. If the alarm still occurs, the SERVOPACK may be faulty. Replace the SERVOPACK.
A.CA0: Encoder Parameter Error	A linear scale fault occurred.	–	Turn the power supply OFF and then ON again. If the alarm still occurs, the linear servomotor may be faulty. Replace the linear servomotor.
	A SERVOPACK fault occurred.	–	Turn the power supply OFF and then ON again. If the alarm still occurs, the SERVOPACK may be faulty. Replace the SERVOPACK.
A.Cb0: Encoder Echoback Error	The linear scale wiring and contact are incorrect.	Check the linear scale wiring.	Correct the linear scale wiring.
	Noise interference occurred due to incorrect specifications of the linear scale connection cables.	–	Use tinned annealed copper twisted-pair or shielded twisted-pair cable with a core of at least 0.12 mm <sup>2</sup> .
	Noise interference occurred because the wiring distance of the linear scale connection cables is too long.	–	The wiring distance must be 20 m max.
	The FG potential varies because of influence from machines, such as welder, on the linear servomotor side.	Check the cables and connectors for linear scale.	Make the grounding for the machine separately from linear scale side FG.
	Excessive vibration and shocks were applied to the linear scale.	Check the operating environment.	Reduce the machine vibration or correctly install the linear servomotor.
	A linear scale fault occurred.	–	Turn the power supply OFF and then ON again. If the alarm still occurs, the linear servomotor may be faulty. Replace the linear servomotor.
	A SERVOPACK fault occurred.	–	Turn the power supply OFF and then ON again. If the alarm still occurs, the SERVOPACK may be faulty. Replace the SERVOPACK.

Alarm: Alarm Name	Cause	Investigative Actions	Corrective Actions
A.CF1: Feedback Option Module Communications Error (Reception error)	Wiring of cable between serial converter unit and SERVOPACK is incorrect or contact is faulty.	Check the linear scale wiring.	Correct the cable wiring.
	The specified cable is not used between serial converter unit and SERVOPACK.	Confirm the linear scale wiring specifications.	Use the specified cable.
	Cable between serial converter unit and SERVOPACK is too long.	Measure the length of the cable for connecting the serial converter unit.	The cable between serial converter unit and SERVOPACK must be 20 m max.
	Sheath of cable between serial converter unit and SERVOPACK is broken.	Check the cable for connecting the serial converter unit.	Replace the cable.
A.CF2: Feedback Option Module Communications Error (Timer stop)	Noise interferes with the cable between serial converter unit and SERVOPACK.	–	Correct the wiring around serial converter unit, e.g., separating input/output signal line from main circuit cable or grounding.
	A serial converter unit fault occurred.	–	Replace the serial converter unit.
	A SERVOPACK fault occurred.	–	Replace the SERVOPACK.
A.d00: Position Error Pulse Overflow (Position error exceeded the value set in the excessive position error alarm level (Pn520))	The contact in the linear servomotor U, V, and W wirings is faulty.	Check the linear servomotor main circuit cable connection.	Confirm that there is no contact fault in the linear servomotor wiring and linear scale wiring.
	The SERVOPACK gains are too low.	Check the SERVOPACK gains to see if they are not too low.	Increase the servo gains (Pn100, Pn102, etc.)
	The frequency of the position reference is too high.	Reduce the reference frequency, and operate the SERVOPACK.	Reduce the position reference frequency or reference acceleration. Or, reconsider the electronic gear ratio.
	The position reference acceleration is too fast.	Reduce the reference acceleration, and operate the SERVOPACK.	Apply the smoothing function, such as using position reference acceleration/deceleration time constant (Pn216).
	Setting of the Pn520 (Excessive Position Error Alarm Level) is too low for the operating condition.	Check the alarm level (Pn520) to see if it is set to an appropriate value.	Set the Pn520 to proper value.
	A SERVOPACK fault occurred.	–	Turn the power supply OFF and then ON again. If the alarm still occurs, the SERVOPACK may be faulty. Replace the SERVOPACK.
A.d01: Position Error Pulse Overflow Alarm at Servo ON	When setting not to clear position error, the linear servomotor moved while the servo was OFF, resulting in position error overflow.	Check the error counter (Un008) while the linear servomotor power is OFF.	Make the setting so that the position error is cleared when the servo is OFF. Or, correct the excessive position error alarm level at servo ON (Pn526).
A.d02: Position Error Pulse Overflow Alarm by Speed Limit at Servo ON	The servo was turned ON while the position error accumulated, and the reference was input while the linear servomotor was running at the speed limit (Pn584). As a result, the position error count exceeded the excessive position error alarm level (Pn520).	–	Set position error to be cleared while in servo OFF status. Or, correct the excessive position error alarm level (Pn520). Or, adjust the speed limit level (Pn584) when servo turns ON.
A.d30: Position Data Overflow	The position data exceeded $\pm 1879048192$ .	Check the reference counter (Un00C).	Reconsider the operating specifications.

Alarm: Alarm Name	Cause	Investigative Actions	Corrective Actions
A.E00: Command Option Module IF Initialization Timeout Error	The connection between the SERVOPACK and the command option module is faulty.	Check the connection between the SERVOPACK and the command option module.	Correctly connect the command option module.
	A command option module fault occurred.	—	Replace the command option module.
	A SERVOPACK fault occurred.	—	Replace the SERVOPACK.
A.E02: Command Option Module IF Synchronization Error 1	The timing of synchronization between the SERVOPACK and command option module changed due to change in the communications cycle of the host controller connected to the command option module.	—	Turn the power supply OFF and then ON again. If the alarm occurs again, restart communications processing from the host controller.
	The connection between the SERVOPACK and the command option module is faulty.	Check the connection between the SERVOPACK and the command option module.	Correctly connect the command option module.
	A command option module fault occurred.	—	Replace the command option module.
	A SERVOPACK fault occurred.	—	Replace the SERVOPACK.
A.E03: Command Option Module IF Communications Data Error	An error occurred due to noise in the communications between the SERVOPACK and the command option module.	—	Take measures against noise.
	The connection between the SERVOPACK and the command option module is faulty.	Check the connection between the SERVOPACK and the command option module.	Correctly connect the command option module.
	A command option module fault occurred.	—	Replace the command option module.
	A SERVOPACK fault occurred.	—	Replace the SERVOPACK.
A.E40: Command Option Module IF Communications Setting Error	A command option module fault occurred.	—	Replace the command option module.
A.E50: Command Option Module IF Synchronization Error 2	The timing of synchronization between the SERVOPACK and command option module changed due to change in the communications cycle of the host controller connected to the command option module.	—	Turn the power supply OFF and then ON again. If the alarm occurs again, restart communications processing from the host controller.
A.E51: Command Option Module IF Synchronization Establishment Error	A command option module fault occurred.	—	Replace the command option module.
A.E60: Command Option Module IF Data Communications Error	An error occurred due to noise in the communications between the SERVOPACK and the command option module.	—	Take measures against noise.
	The connection between the SERVOPACK and the command option module is faulty.	Check the connection between the SERVOPACK and the command option module.	Correctly connect the command option module.
	A command option module fault occurred.	—	Replace the command option module.
	A SERVOPACK fault occurred.	—	Replace the SERVOPACK.



Alarm: Alarm Name	Cause	Investigative Actions	Corrective Actions
A.E61: Command Option Module IF Synchronization Error 3	The timing of synchronization between the SERVOPACK and command option module changed due to change in the communications cycle of the host controller connected to the command option module.	–	Turn the power supply OFF and then ON again. If the alarm occurs again, restart communications processing from the host controller.
	The connection between the SERVOPACK and the command option module is faulty.	Check the connection between the SERVOPACK and the command option module.	Correctly connect the command option module.
	A command option module fault occurred.	–	Replace the command option module.
	A SERVOPACK fault occurred.	–	Replace the SERVOPACK.
A.E70: Command Option Module Detection Failure	The connection between the SERVOPACK and the command option module is faulty.	Check the connection between the SERVOPACK and the command option module.	Correctly connect the command option module.
	The command option module is not connected.	–	Correctly connect the command option module.
	A command option module fault occurred.	–	Replace the command option module.
	A SERVOPACK fault occurred.	–	Replace the SERVOPACK.
A.E71: Safety Option Module Detection Failure	The connection between the SERVOPACK and the safety option module is faulty.	Check the connection between the SERVOPACK and the safety option module.	Correctly connect the safety option module.
	The safety option module was disconnected.	–	Execute Fn014 (Resetting configuration error of option module) with using the digital operator or SigmaWin+ and turn the power supply OFF and then ON again.
	A safety option module fault occurred.	–	Replace the safety option module.
	A SERVOPACK fault occurred.	–	Replace the SERVOPACK.
A.E72: Feedback Option Module Detection Failure	The connection between the SERVOPACK and the feedback option module is faulty.	Check the connection between the SERVOPACK and the feedback option module.	Correctly connect the feedback option module.
	The feedback option module was disconnected.	–	Execute Fn014 (Resetting configuration error of option module) with the digital operator or SigmaWin+ and turn the power supply OFF and then ON again.
	A feedback option module fault occurred.	–	Replace the feedback option module.
	A SERVOPACK fault occurred.	–	Replace the SERVOPACK.
A.E73: Unsupported Option Module	A command option module fault occurred.	–	Replace the command option module.
	A unsupported command option module was connected.	Refer to the catalog of the connected command option module.	Connect a compatible command option module.
A.E74: Unsupported Safety Option Module	A safety option module fault occurred.	–	Replace the safety option module.
	A unsupported safety option module was connected.	Refer to the catalog of the connected safety option module.	Connect a compatible safety option module.

Alarm: Alarm Name	Cause	Investigative Actions	Corrective Actions
A.E75: Unsupported Feedback Option Module	A feedback option module fault occurred.	–	Replace the feedback option module.
	A unsupported feedback option module was connected.	Refer to the catalog of the connected feedback option module or the manual of the SERVOPACK.	Connect a compatible feedback option module.
A.E80: Command Option Module Unmatched Error	The command option module was replaced with a different model.	–	Execute Fn014 (Resetting configuration error of option module) with the digital operator or SigmaWin+ and turn the power supply OFF and then ON again.
A.EA2: DRV Alarm 2 (SERVOPACK WDC error)	The timing of synchronization between the SERVOPACK and command option module changed due to change in the communications cycle of the host controller connected to the command option module.	–	Turn the power supply OFF and then ON again. If the alarm occurs again, restart communications processing from the host controller.
	The connection between the SERVOPACK and the command option module is faulty.	Check the connection between the SERVOPACK and the command option module.	Correctly connect the command option module.
	A command option module fault occurred.	–	Replace the command option module.
	A SERVOPACK fault occurred.	–	Replace the SERVOPACK.
A.Eb1: Safety Function Signal Input Timing Error	The lag between activations of the input signals /HWBB1 and /HWBB2 for the HWBB function is 10 seconds or more.	Measure the time lag between the /HWBB1 and /HWBB2 signals.	The host controller output signal circuits or devices for /HWBB1 and /HWBB2 or the SERVOPACK input signal circuits may be faulty. Alternatively, the input signal cables may be disconnected. Repair or replace them.
A.ED1: Command Option Module IF Command Timeout Error	Processing of the sensor ON command from the command option module is not completed.	–	Input a servo ON command when the linear servomotor is stopped.
	Processing of the sensor ON command from the command option module is not completed.	–	Check that the linear scale is connected correctly and input a sensor ON command when the linear servomotor is stopped.
A.F10: Main Circuit Cable Open Phase (With the main power supply ON, voltage was low for more than 1 sec- ond in an R, S, or T phase.) (Detected when the main power supply was turned ON.)	The three-phase power supply wiring is incorrect.	Check the power supply wiring.	Confirm that the power supply is correctly wired.
	The three-phase power supply is unbalanced.	Measure the voltage at each phase of the three-phase power supply.	Balance the power supply by changing phases.
	A single-phase power is input without setting Pn00B.2 (power supply method for three-phase SERVOPACK) to 1 (single-phase power supply).	Check the power supply and the parameter setting.	Match the parameter setting to the power supply.
	A SERVOPACK fault occurred.	–	Turn the power supply OFF and then ON again. If the alarm still occurs, the SERVOPACK may be faulty. Replace the SERVOPACK.
CPF00: Digital Operator Transmission Error 1	The contact between the digital operator and the SERVOPACK is faulty.	Check the connector contact.	Insert securely the connector or replace the cable.
	Malfunction caused by noise interference	–	Keep the digital operator or the cable away from noise sources.

Alarm: Alarm Name	Cause	Investigative Actions	Corrective Actions
CPF01: Digital Operator Transmission Error 2	A digital operator fault occurred.	–	Disconnect the digital operator and then re-connect it. If the alarm still occurs, the digital operator may be faulty. Replace the digital operator.
	A SERVOPACK fault occurred.	–	Turn the power supply OFF and then ON again. If the alarm still occurs, the SERVOPACK may be faulty. Replace the SERVOPACK.

## 8.2 Warning Displays

The following sections describe troubleshooting in response to warning displays.

The warning name, warning meaning, and warning code output are listed in order of the warning numbers in *8.2.1 List of Warnings*.

The causes of alarms and troubleshooting methods are provided in *8.2.2 Troubleshooting of Warnings*.

### 8.2.1 List of Warnings

The relation between warning displays and warning code outputs are shown below.

Warning Display	Warning Name	Meaning
A.900	Position Error Pulse Overflow	Position error pulse exceeded the parameter settings (Pn520×Pn51E/100).
A.901	Position Error Pulse Overflow Alarm at Servo ON	When the linear servomotor power is turned ON, the position error pulses exceeded the parameter setting (Pn526×Pn528/100).
A.910	Overload	This warning occurs before the overload alarms (A.710 or A.720) occur. If the warning is ignored and operation continues, an overload alarm may occur.
A.911	Vibration	Abnormal vibration at the motor speed was detected. The detection level is the same as A.520. Set whether to output an alarm or warning by “Vibration Detection Switch” of Pn310.
A.920	Regenerative Overload	This warning occurs before the regenerative overload alarm (A.320) occurs. If the warning is ignored and operation continues, a regenerative overload alarm may occur.
A.921	Dynamic Brake Overload	This warning occurs before Dynamic Brake Overload (A.731) alarm occurs. If the warning is ignored and operation continues, a dynamic brake overload alarm may occur.
A.94A	Command Option Module IF Data Setting Warning 1	This warning occurs when there is an error in a parameter number sent to the SERVOPACK from the host controller or command option module.
A.94B	Command Option Module IF Data Setting Warning 2	This warning occurs when out-of-range data is sent to the SERVOPACK from the host controller or command option module.
A.94C	Command Option Module IF Data Setting Warning 3	This warning occurs when there is an error in the parameter data sent to in the SERVOPACK from the host controller or command option module.
A.94D	Command Option Module IF Data Setting Warning 4	This warning occurs when there is an error in the data size sent to the SERVOPACK from the host controller or command option module.
A.94E	Command Option Module IF Data Setting Warning 5	This warning occurs when there is an error in the latch mode settings sent to the SERVOPACK from the host controller or command option module.
A.95A	Command Option Module IF Command Warning 1	This warning occurs when the host controller or command option module outputs an operating command when the operation execution conditions in the SERVOPACK have not been met.
A.95B	Command Option Module IF Command Warning 2	This warning occurs when there is an error in the reference output from the command option module to the SERVOPACK.
A.95D	Command Option Module IF Command Warning 4	This warning occurs when a latch command is output from the command option module to the SERVOPACK during latch operation.
A.95E	Command Option Module IF Command Warning 5	This warning occurs when an unallowed command combination is output to the SERVOPACK from the command option module.
A.95F	Command Option Module IF Command Warning 6	This warning occurs when there is an error in the command output to the SERVOPACK from the command option module.
A.960	Command Option Module IF Communications Warning	This warning occurs when an error occurred in communications between the SERVOPACK and command option module.

Warning Display	Warning Name	Meaning
<b>A.971</b>	Undervoltage	This warning occurs before Undervoltage (A.410) alarm occurs. If the warning is ignored and operation continues, an undervoltage alarm may occur.

- Note 1. Set Pn001.3 = 1 (Outputs both Alarm Codes and Warning Codes) to output warning codes.  
2. If Pn008.2 = 1 (Does not detect warning) is selected, no warnings will be detected.

## 8.2.2 Troubleshooting of Warnings

Refer to the following table to identify the cause of a warning and the action to be taken. Contact your Yaskawa representative if the problem cannot be solved by the described corrective action.

Warning Display	Warning Name	Situation at Warning Occurrence	Cause	Corrective Actions
A.900	Position Error Pulse Overflow	Wiring of the linear servomotor U, V, or W line is incorrect.	Check the wiring of the cable for linear servomotor main circuit.	Check whether there is any loose connection in linear servomotor wiring or linear scale wiring.
		The SERVOPACK gain is too low.	Check the SERVOPACK gain.	Increase the servo gain by using the function such as advanced autotuning.
		The position reference acceleration is too high.	Lower the position reference acceleration.	Apply a smoothing function, such as a position reference acceleration/deceleration time constant (Pn216).
		The excessive position error alarm level (Pn520) is too low for the operating conditions.	Check the excessive position error alarm level (Pn520).	Set an appropriate value for the Pn520.
		A SERVOPACK fault occurred.	—	Turn the power supply OFF and then ON again. If the alarm still occurs, the SERVOPACK may be faulty. Replace the SERVOPACK.
A.901	Position Error Pulse Overflow Alarm at Servo ON	When the linear servomotor power was OFF, the linear servomotor moved without clearing the counter for position error pulses. The number of position error pulses exceeded the maximum number of pulses allowed.	Check the error counter (Un008) in servo OFF state.	Make the setting so that the position error pulse is cleared when the linear servomotor power is OFF. Or, set an appropriate value for the excessive position error warning level at servo ON (Pn528).
A.910	Overload: Warning before alarm A.710 or A.720 occurs	The linear servomotor or linear scale wiring is incorrect or the connection is faulty.	Check the wiring.	Correct the linear servomotor and linear scale wiring if they are wrong.
		The linear servomotor is in excess of the overload protective characteristics.	Check the overload characteristics of the linear servomotor and reference input.	Reconsider the load and operation conditions. Or, check the linear servomotor capacity.
		The linear servomotor is not driven due to a mechanical factor and the operating load has become excessive.	Check the reference input and motor speed.	Improve the mechanical factor.
		A SERVOPACK fault occurred.	—	The SERVOPACK may be faulty. Replace the SERVOPACK.
A.911	Vibration	Abnormal vibration was detected while the linear servomotor was moving.	Check whether unusual sound is generated from the linear servomotor, and check the speed and force waveform of the linear servomotor.	Lower the motor speed or the lower the servo gain by using the function such as one-parameter tuning.
		The mass ratio (Pn103) is larger than the actual value or greatly changes.	Check the mass value.	Set an appropriate value for the mass ratio (Pn103).

Warning Display	Warning Name	Situation at Warning Occurrence	Cause	Corrective Actions
A.920	Regenerative Overload: Warning before the alarm A.320 occurs	The power supply voltage exceeds the specified range.	Measure the power supply voltage.	Set the power supply voltage within the specified range.
		The external regenerative resistance, SERVOPACK capacity, or regenerative resistor capacity is insufficient or a continuous regenerative state occurs.	Check the operating conditions or capacity using the capacity selection software SigmaJunmaSize+, etc.	Change the regenerative resistance, regenerative resistor capacity, or SERVOPACK capacity. Reconsider the operating conditions using the capacity selection software SigmaJunmaSize+, etc.
		Regenerative power continuously flowed back because negative load was continuously applied.	Check the load on the linear servomotor during operation.	Reconsider the system including the servo, machine, and operation conditions.
A921	Dynamic Brake Overload: Warning before the alarm A.731 occurs	The linear servomotor is driven by an external force.	Check the operating conditions.	Do not drive the linear servomotor with external force.
		The moving energy at a DB stop exceeds the DB resistance capacity.	Check the operating frequency of the DB with power consumed by DB resistance (Un00B).	<ul style="list-style-type: none"> <li>Reduce the linear servomotor reference speed.</li> <li>Reduce the mass.</li> <li>Reduce the number of times of the DB stop operation.</li> </ul>
		A SERVOPACK fault occurred.	—	The SERVOPACK may be faulty. Replace the SERVOPACK.
A.94A	Command Option Module IF Data Setting Warning 1	An incorrect parameter number was sent to the SERVOPACK from the host controller or command option module.	—	Specify the correct parameter number.
A.94B	Command Option Module IF Data Setting Warning 2	Out-of-range data was sent to the SERVOPACK from the host controller or command option module.	—	Specify the value of the parameter within the allowable range.
A.94C	Command Option Module IF Data Setting Warning 3	Incorrect parameter data was sent to the SERVOPACK from the host controller or command option module.	—	Specify the value of the parameter within the allowable range.
A.94D	Command Option Module IF Data Setting Warning 4	The incorrect parameter size was sent to the SERVOPACK from the host controller or command option module.	—	Specify the correct parameter size.
A.94E	Command Option Module IF Data Setting Warning 5	Incorrect latch mode settings were sent to the SERVOPACK from the host controller or command option module.	—	Set a proper value for the latch mode.
A.95A	Command Option Module IF Command Warning 1	The host controller or command option module sent a operating command when the operation execution conditions in the SERVOPACK had not been satisfied.	—	Send a command after the operation conditions are satisfied.

Warning Display	Warning Name	Situation at Warning Occurrence	Cause	Corrective Actions
<b>A.95B</b>	Command Option Module IF Command Warning 2	The command option module sent a command that is not supported by the SERVOPACK.	—	Send a command that is supported by the SERVOPACK.
<b>A.95D</b>	Command Option Module IF Command Warning 4	A latch command was sent from the command option module during latch operation.	—	Review the input sequence for the latch command.
<b>A.95E</b>	Command Option Module IF Command Warning 5	An unallowed command combination was output to the SERVOPACK from the command option module.	—	Send a command that can be combined.
<b>A.95F</b>	Command Option Module IF Command Warning 6	The command option module sent a command that is not supported by the SERVOPACK.	—	Send a command that is supported by the SERVOPACK.
<b>A.960</b>	Command Option Module IF Communications Warning	An error occurred in communications between the SERVOPACK and command option module due to noise.	—	Take measures against noise.
		The connection between the SERVOPACK and the command option module is faulty.	Check the connection between the SERVOPACK and the command option module.	Correctly connect the command option module.
		A command option module fault occurred.	—	Replace the command option module.
		A SERVOPACK fault occurred.	—	Replace the SERVOPACK.



Warning Display	Warning Name	Situation at Warning Occurrence	Cause	Corrective Actions
<b>A.971</b>	Undervoltage	<ul style="list-style-type: none"> <li>• For 100-VAC SERVOPACKs: The AC power supply voltage is 60 V or below.</li> <li>• For 200-VAC SERVOPACKs: The AC power supply voltage is 140 V or below.</li> <li>• For 400-VAC SERVOPACKs: The AC power supply voltage is 280 V or below.</li> </ul>	Measure the power supply voltage.	Use a power supply voltage within the specified range.
		The power supply voltage dropped during operation.	Measure the power supply voltage.	Increase the power supply capacity.
		An instantaneous power failure occurred.	Measure the power supply voltage.	Lower the instantaneous power cut hold time (Pn509).
		The fuse in the SERVOPACK is burned out.	—	Replace the SERVOPACK and connect an AC/DC reactor to the SERVOPACK.
		A SERVOPACK fault occurred.	—	The SERVOPACK may be faulty. Replace the SERVOPACK.

## 8.3 Troubleshooting Malfunction Based on Operation and Conditions of the Linear Servomotor

Troubleshooting for the malfunctions based on the operation and conditions of the linear servomotor is provided in this section.

Be sure to turn OFF the servo system before troubleshooting items outlined in bold in the table.

Problem	Probable Cause	Investigative Actions	Corrective Actions
Linear Servomotor Does Not Start When Using JOG Operation or Host Controller Reference.	The control power supply is not ON.	Check voltage between control power supply terminals.	Correct the control power circuit.
	The main circuit power supply is not ON.	Check the voltage between power supply terminals.	Correct the power circuit.
	Wrong wiring or disconnection of I/O signal connector CN1	Check if the connector CN1 is properly inserted and connected.	Correct the connector CN1 connection.
	Linear servomotor or serial converter unit wiring disconnected.	Check the wiring.	Correct the wiring.
	The polarity detection is not executed.	Check the parameter Pn080.	Correct the setting of Pn080.
		Check the command sent from the host controller.	When using an incremental linear scale, send the servo ON command. When using an absolute linear scale, execute polarity detection (Fn080).
	The safety input signal (/HWBB1 or /HWBB2) remains OFF.	Check the /HWBB1 or /HWBB2 input signal.	Set the /HWBB1 or /HWBB2 input signal to ON. When not using the safety function, mount the safety function jumper connector (provided as an accessory) on the CN8.
A SERVOPACK fault occurred.	–	Replace the SERVOPACK.	
Linear Servomotor Starts in JOG Operation but Does Not Start by Host Controller Reference.	Overloaded	Run under no load.	Reduce load or replace with a larger capacity linear servomotor.
	Speed/position references not input	Check reference input pins.	Input speed/position references correctly.
	Settings for Pn50A and Pn50B "Input Signal Selection" are incorrect.	Check settings of parameters Pn50A and Pn50B.	Correct the settings for Pn50A and Pn50B "Input Signal Selection."
	Linear scale type differs from parameter setting (Pn002.2).	Check the linear scale type and setting of parameter Pn002.2.	Set parameter Pn002.2 to the linear scale type being used.
	A servo ON command was not input.	Check the command sent from the host controller.	Send a servo ON command.
	A sensor ON command was not input.	Check the command sent from the host controller.	Send the command in the correct sequence to the SERVOPACK.
	The forward run prohibited (P-OT) or reverse run prohibited (N-OT) input signal is turned OFF.	Check P-OT or N-OT input signal.	Turn P-OT or N-OT input signal ON.

Problem	Probable Cause	Investigative Actions	Corrective Actions
Linear Servomotor Moves Instantaneously, and then Stops	Linear servomotor wiring is incorrect.	Check the linear servomotor wiring.	Correct the linear servomotor wiring.
	Serial converter unit wiring is incorrect.	Check the serial converter unit wiring.	Correct the serial converter unit wiring.
	Linear scale wiring is incorrect.	Check the linear scale wiring.	Correct the linear scale wiring.
	Linear scale pitch (Pn282) is incorrect.	Check the setting of Pn282.	Correct the setting of Pn282.
	Linear scale counting up direction and motor moving coil forward direction do not agree.	Check the directions.	Change the setting of Pn080.1 (Motor Phase Selection). Match the linear scale direction and moving coil direction.
	Polarity detection is not performed correctly.	Check if the value of Un004 (Electric Angle 2, angle from polarity origin) at an arbitrary position is between $\pm 10$ degrees.	Correct the settings for the polarity detection related parameter.
Linear Servomotor Speed Unstable	Wiring connection to linear servomotor is defective.	Check connection of power lead (phases U, V, and W) and the connectors of linear scale connection cables.	Tighten any loose terminals or connectors.
Linear Servomotor Moves Without Reference Input	A SERVOPACK fault occurred.	–	Replace the SERVOPACK.
	Linear scale counting up direction and motor moving coil forward direction do not agree.	Check the directions.	Change the setting of Pn080.1 (Motor Phase Selection). Match the linear scale direction and moving coil direction.
	Polarity detection is not performed correctly.	Check if the value of Un004 (Electric Angle 2, angle from polarity origin) at an arbitrary position is between $\pm 10$ degrees.	Correct the settings for the polarity detection related parameter.
DB (dynamic brake) Does Not Operate	Improper setting of parameter Pn001.0	Check the setting of parameter Pn001.0 (Servo OFF or Alarm Gr.1 Stop Mode).	Correct the setting of parameter Pn001.0.
	DB resistor disconnected	Check if excessive mass, motor overspeed, or DB frequent activation has occurred.	Replace the SERVOPACK, and reconsider the load.
	DB drive circuit fault	–	DB circuit parts are faulty. Replace the SERVOPACK.
Abnormal Noise from Linear Servomotor	The linear servomotor largely vibrated during execution of tuning-less function (factory setting).	Check the motor speed waveform.	Reduce the load so that the mass ratio becomes within the allowable value, or increase the load level or lower the rigidity level for the tuning-less level setting (Fn200).
	Mounting not secured	Check if there are any loosen mounting screws.	Tighten the mounting screws.
	Vibration source on the driven machine	Check the machine movable section for foreign matter, damage or deformity.	Contact the machine manufacturer.
	Noise interference due to incorrect I/O signal cable specifications	The specifications of I/O signal cables must be: Twisted-pair or twisted-pair shielded wire with core $0.12 \text{ mm}^2$ min. and tinned annealed copper twisted wire.	Use the specified I/O signal cables.
	Noise interference due to long distance of I/O signal cable	Check the I/O signal cable length.	Shorten the I/O signal cable length to 3 m or less.

Problem	Probable Cause	Investigative Actions	Corrective Actions
Abnormal Noise from Linear Servomotor (cont'd)	Noise interference due to incorrect specifications of cable for connecting serial converter unit.	The specifications of cable for connecting serial converter unit must be: Twisted-pair or twisted-pair shielded wire with core 0.12 mm <sup>2</sup> min. and tinned annealed copper twisted wire.	Use the specified cable for connecting serial converter unit.
	Noise interference because the cable for connecting serial converter unit is too long	Check the length of the cable for connecting serial converter unit.	The length of cable for connecting serial converter unit must be 20 m max.
	Noise interference because the cable for connecting serial converter unit is damaged	Check the cable for connecting serial converter unit to see if it is not damaged or bent.	Replace the cable for connecting serial converter unit, and reconsider the layout of the cable for connecting serial converter unit.
	Excessive noise to the cable for connecting serial converter unit	Check if the cable for connecting serial converter unit is not bundled with high-current line or not near the high-current line.	Modify the cable layout so that no surge from high-current line is applied to the cable for connecting serial converter unit.
	FG electrical potential varies by influence of such machines on the linear servomotor side as welders.	Check if the machine is correctly grounded.	Ground the machine separately from linear scale side FG.
	SERVOPACK pulse counting error due to noise	Check if there is noise interference on the I/O signal cable from the serial converter unit.	Take measure against noise for the serial converter unit wiring.
	Excessive vibration and shock to the serial converter unit	Check if vibration from the machine occurred or serial converter unit installation is incorrect. (Mounting surface accuracy, or fixing.)	Reduce vibration from the machine, or correct the serial converter unit installation.
	A serial converter unit fault occurred.	–	Replace the serial converter unit.
	A linear scale fault occurred.	–	Replace the linear scale.
Linear Servomotor Vibrates at about 200 to 400 Hz	Unbalanced servo gains	Check to see if the servo gains have been correctly adjusted.	Execute the advanced autotuning.
	Speed loop gain value (Pn100) is too high.	Check the speed loop gain value (Pn100). Factory setting: $K_v = 40.0$ Hz	Reduce the speed loop gain (Pn100).
	Position loop gain value (Pn102) is too high.	Check the position loop gain value (Pn102). Factory setting: $K_p = 40.0/s$	Reduce the position loop gain (Pn102).
	Incorrect speed loop integral time constant (Pn101) setting	Check the speed loop integral time constant (Pn101) setting. Factory setting: $T_i = 20.0$ ms	Correct the speed loop integral time constant (Pn101) setting.
	Incorrect mass ratio (Pn103) setting	Check the mass ratio (Pn103) setting.	Correct the mass ratio (Pn103) setting.

Problem	Probable Cause	Investigative Actions	Corrective Actions
High Speed Overshoot on Starting and Stopping	Unbalanced servo gains	Check to see if the servo gains have been correctly adjusted.	Execute the advanced autotuning.
	Speed loop gain value (Pn100) is too high.	Check the speed loop gain value (Pn100). Factory setting: $K_v = 40.0$ Hz	Reduce the speed loop gain (Pn100).
	Position loop gain value (Pn102) is too high.	Check the position loop gain value (Pn102). Factory setting: $K_p = 40.0/s$	Reduce the position loop gain (Pn102).
	Incorrect speed loop integral time constant (Pn101) setting	Check the speed loop integral time constant (Pn101) setting. Factory setting: $T_i = 20.0$ ms	Correct the speed loop integral time constant (Pn101) setting.
	Incorrect mass ratio (Pn103) setting	Check the mass ratio (Pn103) setting.	Correct the mass ratio (Pn103) setting.
	The force reference is saturated.	Check the force reference waveform.	Use the mode switch function.
	The force limit (Pn483, Pn484) is set to the initial value.	Initial value of force limit: Pn483 = 30% Pn484 = 30%	Set Pn483 and Pn484 (Force Limit) to an appropriate value.
Overtravel (OT)	Forward or reverse run prohibited signal is input.	Check if the voltage of input signal external power supply (+24 V) is correct.	Correct external power supply (+24 V) voltage.
		Check if the overtravel limit switch operates properly.	Correct the overtravel limit switch.
		Check if the overtravel limit switch is connected correctly.	Correct the overtravel limit switch wiring.
		Check the settings for Pn50A and Pn50B.	Set the parameters correctly.
	Forward or reverse run prohibited signal is malfunctioning.	Check the fluctuation of the input signal external power supply (+24 V) voltage.	Stabilize the external power supply (+24 V) voltage.
		Check if the overtravel limit switch operates correctly.	Stabilize the operation of the overtravel limit switch.
		Check if the overtravel limit switch wiring is correct. (check for damaged cables or loosen screws.)	Correct the overtravel limit switch wiring.
	Incorrect forward or reverse run prohibited signal (P-OT/N-OT) allocation (parameters Pn50A.3, Pn50B.0)	Check if the P-OT signal is allocated in Pn50A.3.	If another signal is allocated in Pn50A.3, select P-OT.
		Check if the N-OT signal is allocated in Pn50B.0.	If another signal is allocated in Pn50B.0, select N-OT.
	Incorrect servomotor stop method selection	Check Pn001.0 and Pn001.1 when the linear servomotor power is OFF.	Select a linear servomotor stop method other than "coast to stop."
Check Pn001.0 and Pn001.1 when in force control.		Select a linear servomotor stop method other than "coast to stop."	
Improper Position to Stop by Overtravel (OT) Signal	Improper limit switch position and dog length	–	Install the limit switch at the appropriate position.
	The overtravel limit switch position is too short for the coasting distance.	–	Install the overtravel limit switch at the appropriate position.

Problem	Probable Cause	Investigative Actions	Corrective Actions
Position Error (without alarm)	Noise interference due to improper specifications of the cable for connecting serial converter unit.	The specifications of the cable for connecting serial converter unit must be: Twisted-pair or twisted-pair shielded wire with core 0.12 mm <sup>2</sup> min. and tinned annealed copper twisted wire.	Use the cable for connecting serial converter unit with the specified specifications.
	Noise interference because the length of the cable for connecting serial converter unit is too long.	Check the length of the cable for connecting serial converter unit.	The length of the cable for connecting serial converter unit must be 20 m max.
	Noise influence due to damaged cable for connecting serial converter unit	Check the cable for connecting serial converter unit to see if it is bent or its sheath is damaged.	If the cable is damaged, replace the cable for connecting serial converter unit, and correct the cable layout.
	Excessive noise interference to the cable for connecting serial converter unit	Check if the cable for connecting serial converter unit is bundled with a high-current line or near high-current line.	Change the layout of the cable for connecting serial converter unit so that no surge voltage is applied.
	FG electrical potential varies by influence of such machines on the linear servomotor side as welders.	Check if the machine is correctly grounded.	Ground the machine separately from encoder side FG.
	SERVOPACK pulse count error due to noise	Check if the I/O signal cable from the serial converter unit is influenced by noise.	Take a measure against noise for the serial converter unit wiring.
	Excessive vibration and shock to the serial converter unit	Check if machine vibration occurred or serial converter unit mounting such as mounting surface precision, fixing is incorrect.	Reduce the machine vibration or mount the serial converter unit securely.
	Noise interference due to improper I/O signal cable specifications	The specifications of the I/O signal cable must be: Twisted-pair or twisted-pair shielded wire with core 0.12 mm <sup>2</sup> min. and tinned annealed copper twisted wire.	Use I/O signal cable with the specified specifications.
	Noise interference due to length of I/O signal cable	Check the I/O signal cable length.	The I/O signal cable length must be less than 3 m.
	A linear scale fault occurred. (The pulse count does not change.)	–	Replace the linear servomotor.
A SERVOPACK fault occurred.	–	Replace the SERVOPACK.	
Servomotor Overheated	Ambient operating temperature is too high.	Measure the linear servomotor ambient operating temperature.	Reduce the ambient operating temperature to 40°C max.
	Linear servomotor surface is dirty.	Check visually.	Clean dust and oil from linear servomotor surface.
	Linear servomotor overloaded	Check the load status with monitor.	If overloaded, reduce load or replace with larger capacity SERVOPACK and linear servomotor.
	Polarity detection is not performed correctly.	Check if the value of Un004 (Electric Angle 2) at an arbitrary position is between ±10 degrees.	Correct the settings for the polarity detection related parameter.

---

## Appendix

9.1 List of Parameters .....	9-2
9.1.1 Utility Functions .....	9-2
9.1.2 Parameters .....	9-3
9.2 Monitor Modes .....	9-23
9.3 Parameter Recording Table .....	9-24

## 9.1 List of Parameters

### 9.1.1 Utility Functions

The following table lists the available utility functions. .

Function No.	Function	Reference Section
Fn000	Alarm history display	6.2
Fn002	JOG operation	6.3
Fn003	Origin search	6.4
Fn004	Program JOG operation	6.5
Fn005	Initializing parameter settings	6.6
Fn006	Clearing alarm history	6.7
Fn00C	Offset adjustment of analog monitor output	6.8
Fn00D	Gain adjustment of analog monitor output	6.9
Fn00E	Automatic offset-signal adjustment of motor current detection signal	6.10
Fn00F	Manual offset-signal adjustment of motor current detection signal	6.11
Fn010	Write prohibited setting	6.12
Fn011	Servomotor model display	6.13
Fn012	Software version display	6.14
Fn014	Resetting configuration error of option module	6.15
Fn01B	Vibration detection level initialization	6.16
Fn01E	Display of SERVOPACK and servomotor ID	6.17
Fn020	Origin setting*	4.5.3
Fn030	Software reset	6.18
Fn080	Polarity detection*	4.5.2
Fn200	Tuning-less level setting	5.2.2
Fn201	Advanced autotuning	5.3.2
Fn202	Advanced autotuning by reference	5.4.2
Fn203	One-parameter tuning	5.5.2
Fn204	Anti-resonance control adjustment function	5.6.2
Fn205	Vibration suppression function	5.7.2
Fn206	EasyFFT	6.19
Fn207	Online vibration monitor	6.20

\* For details, refer to *Σ-V Series User's Manual Setup for Linear Motor* (SIEP S800000 44).

Note: A setting may be write-prohibited if the digital operator displays "NO-OP" when any of the above utility function is executed. For details, refer to 6.12 *Write Prohibited Setting (Fn010)*.



## 9.1.2 Parameters

Parameter No.	Name	Setting Range	Units	Factory Setting	When Enabled	Classification	Reference Section																																	
Pn000	Basic Function Select Switch 0	0000 to 00B3	–	0000	After restart	Setup	–																																	
	<table border="0"> <tr> <td style="text-align: center;">4th digit</td> <td style="text-align: center;">3rd digit</td> <td style="text-align: center;">2nd digit</td> <td style="text-align: center;">1st digit</td> <td colspan="4"></td> </tr> <tr> <td style="text-align: center;">n.</td> <td style="text-align: center;"><input type="checkbox"/></td> <td style="text-align: center;"><input type="checkbox"/></td> <td style="text-align: center;"><input type="checkbox"/></td> <td style="text-align: center;"><input type="checkbox"/></td> <td colspan="3"></td> <td></td> </tr> </table>								4th digit	3rd digit	2nd digit	1st digit					n.	<input type="checkbox"/>	<input type="checkbox"/>	<input type="checkbox"/>	<input type="checkbox"/>																			
	4th digit	3rd digit	2nd digit	1st digit																																				
	n.	<input type="checkbox"/>	<input type="checkbox"/>	<input type="checkbox"/>	<input type="checkbox"/>																																			
	<table border="1"> <tr> <td colspan="4">Direction Selection</td> <td colspan="4">(Refer to 4.2.2)</td> </tr> <tr> <td style="text-align: center;">0</td> <td colspan="7">Sets the linear scale counting up (phase-A lead) direction as forward direction.</td> </tr> <tr> <td style="text-align: center;">1</td> <td colspan="7">Sets the linear scale counting down (phase-B lead) direction as forward direction. (Reverse Movement Mode)</td> </tr> <tr> <td style="text-align: center;">2 to 3</td> <td colspan="7">Reserved (Do not change.)</td> </tr> </table>								Direction Selection				(Refer to 4.2.2)				0	Sets the linear scale counting up (phase-A lead) direction as forward direction.							1	Sets the linear scale counting down (phase-B lead) direction as forward direction. (Reverse Movement Mode)							2 to 3	Reserved (Do not change.)						
	Direction Selection				(Refer to 4.2.2)																																			
	0	Sets the linear scale counting up (phase-A lead) direction as forward direction.																																						
	1	Sets the linear scale counting down (phase-B lead) direction as forward direction. (Reverse Movement Mode)																																						
	2 to 3	Reserved (Do not change.)																																						
	Reserved (Do not change.)																																							
Reserved (Do not change.)																																								
Reserved (Do not change.)																																								
Reserved (Do not change.)																																								
Reserved (Do not change.)																																								
Reserved (Do not change.)																																								
Pn001	Application Function Select Switch 1	0000 to 1122	–	0000	After restart	Setup	–																																	
	<table border="0"> <tr> <td style="text-align: center;">4th digit</td> <td style="text-align: center;">3rd digit</td> <td style="text-align: center;">2nd digit</td> <td style="text-align: center;">1st digit</td> <td colspan="4"></td> </tr> <tr> <td style="text-align: center;">n.</td> <td style="text-align: center;"><input type="checkbox"/></td> <td style="text-align: center;"><input type="checkbox"/></td> <td style="text-align: center;"><input type="checkbox"/></td> <td style="text-align: center;"><input type="checkbox"/></td> <td colspan="3"></td> <td></td> </tr> </table>								4th digit	3rd digit	2nd digit	1st digit					n.	<input type="checkbox"/>	<input type="checkbox"/>	<input type="checkbox"/>	<input type="checkbox"/>																			
	4th digit	3rd digit	2nd digit	1st digit																																				
	n.	<input type="checkbox"/>	<input type="checkbox"/>	<input type="checkbox"/>	<input type="checkbox"/>																																			
	<table border="1"> <tr> <td colspan="4">Servomotor Power OFF or Alarm Gr.1 Stop Mode</td> <td colspan="4">(Refer to 4.2.8)</td> </tr> <tr> <td style="text-align: center;">0</td> <td colspan="7">Stops the linear servomotor by applying DB (dynamic brake).</td> </tr> <tr> <td style="text-align: center;">1</td> <td colspan="7">Stops the linear servomotor by applying dynamic brake (DB) and then releases DB.</td> </tr> <tr> <td style="text-align: center;">2</td> <td colspan="7">Makes the linear servomotor coast to a stop state without using the dynamic brake (DB).</td> </tr> </table>								Servomotor Power OFF or Alarm Gr.1 Stop Mode				(Refer to 4.2.8)				0	Stops the linear servomotor by applying DB (dynamic brake).							1	Stops the linear servomotor by applying dynamic brake (DB) and then releases DB.							2	Makes the linear servomotor coast to a stop state without using the dynamic brake (DB).						
	Servomotor Power OFF or Alarm Gr.1 Stop Mode				(Refer to 4.2.8)																																			
	0	Stops the linear servomotor by applying DB (dynamic brake).																																						
	1	Stops the linear servomotor by applying dynamic brake (DB) and then releases DB.																																						
	2	Makes the linear servomotor coast to a stop state without using the dynamic brake (DB).																																						
	<table border="1"> <tr> <td colspan="4">Overtravel (OT) Stop Mode</td> <td colspan="4">(Refer to 4.2.3)</td> </tr> <tr> <td style="text-align: center;">0</td> <td colspan="7">Same setting as Pn001.0 (Stops the linear servomotor by applying DB or by coasting).</td> </tr> <tr> <td style="text-align: center;">1</td> <td colspan="7">Sets the force of Pn406 to the maximum value, decelerates the linear servomotor to a stop, and then sets it to servolock state.</td> </tr> <tr> <td style="text-align: center;">2</td> <td colspan="7">Sets the force of Pn406 to the maximum value, decelerates the linear servomotor to a stop, and then sets it to coasting state.</td> </tr> </table>								Overtravel (OT) Stop Mode				(Refer to 4.2.3)				0	Same setting as Pn001.0 (Stops the linear servomotor by applying DB or by coasting).							1	Sets the force of Pn406 to the maximum value, decelerates the linear servomotor to a stop, and then sets it to servolock state.							2	Sets the force of Pn406 to the maximum value, decelerates the linear servomotor to a stop, and then sets it to coasting state.						
Overtravel (OT) Stop Mode				(Refer to 4.2.3)																																				
0	Same setting as Pn001.0 (Stops the linear servomotor by applying DB or by coasting).																																							
1	Sets the force of Pn406 to the maximum value, decelerates the linear servomotor to a stop, and then sets it to servolock state.																																							
2	Sets the force of Pn406 to the maximum value, decelerates the linear servomotor to a stop, and then sets it to coasting state.																																							
<table border="1"> <tr> <td colspan="4">AC/DC Power Input Selection</td> <td colspan="4">(Refer to 3.1.5)</td> </tr> <tr> <td style="text-align: center;">0</td> <td colspan="7">Not applicable to DC power input: Input AC power supply through L1, L2 (, and L3) terminals.</td> </tr> <tr> <td style="text-align: center;">1</td> <td colspan="7">Applicable to DC power input: Input DC power supply between B1/ + and – , or input DC power supply between B1 and –2.</td> </tr> </table>								AC/DC Power Input Selection				(Refer to 3.1.5)				0	Not applicable to DC power input: Input AC power supply through L1, L2 (, and L3) terminals.							1	Applicable to DC power input: Input DC power supply between B1/ + and – , or input DC power supply between B1 and –2.															
AC/DC Power Input Selection				(Refer to 3.1.5)																																				
0	Not applicable to DC power input: Input AC power supply through L1, L2 (, and L3) terminals.																																							
1	Applicable to DC power input: Input DC power supply between B1/ + and – , or input DC power supply between B1 and –2.																																							
Reserved (Do not change.)																																								
Reserved (Do not change.)																																								
Reserved (Do not change.)																																								
Reserved (Do not change.)																																								

Parameter No.	Name	Setting Range	Units	Factory Setting	When Enabled	Classification	Reference Section	
Pn002	Application Function Select Switch 2	0000 to 4113	–	0000	After restart	Setup	–	
	<div style="display: flex; justify-content: space-around;"> <span>4th digit</span> <span>3rd digit</span> <span>2nd digit</span> <span>1st digit</span> </div> n. <input type="checkbox"/> <input type="checkbox"/> <input type="checkbox"/> <input type="checkbox"/>	<b>Force Limit Reference Selection for Command Option Module*1</b>						
		0	Disables the force limit reference from the Command Option Module.					
		1	Enables the force limit reference from the Command Option Module.					
		2	Reserved (Do not change.)					
	3	Enables the force limit reference from the Command Option Module when external input signals P-CL and N-CL are enabled.						
		<b>Speed Limit Reference Selection for Command Option Module*1</b>						
		0	Disables the speed limit reference when force limit is used from the Command Option Module.					
	1	Enables the speed limit reference when force limit is used from the Command Option Module.						
		<b>Absolute Linear Scale Usage</b>						
		0	Uses absolute linear scale as an absolute linear scale.					
	1	Uses absolute linear scale as an incremental linear scale.						
		<b>Reserved (Do not change.)</b>						
	Pn006	Application Function Select Switch 6	0000 to 005F	–	0002	Immediately	Setup	–
		<div style="display: flex; justify-content: space-around;"> <span>4th digit</span> <span>3rd digit</span> <span>2nd digit</span> <span>1st digit</span> </div> n. <input type="checkbox"/> <input type="checkbox"/> <input type="checkbox"/> <input type="checkbox"/>	<b>Analog Monitor 1 Signal Selection (Refer to 5.1.3)</b>					
00			Motor speed (1 V/1000 mm/s)					
01			Speed reference (1 V/1000 mm/s)					
02			Force reference (1 V/100%)					
03		Position error (0.05 V/1 reference unit)						
04		Position amplifier error (after electronic gears) (0.05 V/ 1 encoder pulse unit)						
05		Position reference speed (1 V/1000 mm/s)						
06		Reserved (Do not change.)						
07		Reserved (Do not change.)						
08		Positioning completion (positioning completed: 5 V, positioning not completed: 0 V)						
09		Speed feedforward (1 V/1000 mm/s)						
0A		Force feedforward (1 V/100%)						
0B		Active gain (1st gain: 1 V, 2nd gain: 2 V)						
0C		Completion of position reference (completed: 5 V, not completed: 0 V)						
0D		Reserved (Do not change.)						
		<b>Reserved (Do not change.)</b>						
		<b>Reserved (Do not change.)</b>						

\*1. For details on this function, refer to the manual of the connected Command Option Module.

Parameter No.	Name	Setting Range	Units	Factory Setting	When Enabled	Classification	Reference Section																																																			
Pn007	Application Function Select Switch 7	0000 to 005F	–	0000	Immediately	Setup	–																																																			
	<div style="display: flex; align-items: flex-start;"> <div style="margin-right: 20px;"> <p>n. <input type="checkbox"/> 4th digit</p> <p><input type="checkbox"/> 3rd digit</p> <p><input type="checkbox"/> 2nd digit</p> <p><input type="checkbox"/> 1st digit</p> </div> <table border="1" style="width: 100%; border-collapse: collapse;"> <tr> <td colspan="2" style="text-align: right;"><b>Analog Monitor 2 Signal Selection</b></td> <td style="text-align: right;">(Refer to 5.1.3)</td> </tr> <tr><td>00</td><td>Motor speed (1 V/1000 mm/s)</td><td></td></tr> <tr><td>01</td><td>Speed reference (1 V/1000 mm/s)</td><td></td></tr> <tr><td>02</td><td>Force reference (1 V/100%)</td><td></td></tr> <tr><td>03</td><td>Position error (0.05 V/1 reference unit)</td><td></td></tr> <tr><td>04</td><td>Position amplifier error (after electronic gears) (0.05 V/ 1 encoder pulse unit)</td><td></td></tr> <tr><td>05</td><td>Position reference speed (1 V/1000 mm/s)</td><td></td></tr> <tr><td>06</td><td>Reserved (Do not change.)</td><td></td></tr> <tr><td>07</td><td>Reserved (Do not change.)</td><td></td></tr> <tr><td>08</td><td>Positioning completion reference (positioning completed: 5 V, positioning not completed: 0 V)</td><td></td></tr> <tr><td>09</td><td>Speed feedforward (1 V/1000 mm/s)</td><td></td></tr> <tr><td>0A</td><td>Force feedforward (1 V/100%)</td><td></td></tr> <tr><td>0B</td><td>Active gain (1st gain: 1 V, 2nd gain: 2 V)</td><td></td></tr> <tr><td>0C</td><td>Completion of position reference (completed: 5 V not completed: 0 V)</td><td></td></tr> <tr><td>0D</td><td>Reserved (Do not change.)</td><td></td></tr> <tr><td colspan="3" style="background-color: #cccccc;">Reserved (Do not change.)</td></tr> <tr><td colspan="3" style="background-color: #cccccc;">Reserved (Do not change.)</td></tr> </table> </div>							<b>Analog Monitor 2 Signal Selection</b>		(Refer to 5.1.3)	00	Motor speed (1 V/1000 mm/s)		01	Speed reference (1 V/1000 mm/s)		02	Force reference (1 V/100%)		03	Position error (0.05 V/1 reference unit)		04	Position amplifier error (after electronic gears) (0.05 V/ 1 encoder pulse unit)		05	Position reference speed (1 V/1000 mm/s)		06	Reserved (Do not change.)		07	Reserved (Do not change.)		08	Positioning completion reference (positioning completed: 5 V, positioning not completed: 0 V)		09	Speed feedforward (1 V/1000 mm/s)		0A	Force feedforward (1 V/100%)		0B	Active gain (1st gain: 1 V, 2nd gain: 2 V)		0C	Completion of position reference (completed: 5 V not completed: 0 V)		0D	Reserved (Do not change.)		Reserved (Do not change.)			Reserved (Do not change.)		
	<b>Analog Monitor 2 Signal Selection</b>		(Refer to 5.1.3)																																																							
	00	Motor speed (1 V/1000 mm/s)																																																								
	01	Speed reference (1 V/1000 mm/s)																																																								
	02	Force reference (1 V/100%)																																																								
	03	Position error (0.05 V/1 reference unit)																																																								
	04	Position amplifier error (after electronic gears) (0.05 V/ 1 encoder pulse unit)																																																								
	05	Position reference speed (1 V/1000 mm/s)																																																								
	06	Reserved (Do not change.)																																																								
	07	Reserved (Do not change.)																																																								
	08	Positioning completion reference (positioning completed: 5 V, positioning not completed: 0 V)																																																								
	09	Speed feedforward (1 V/1000 mm/s)																																																								
	0A	Force feedforward (1 V/100%)																																																								
	0B	Active gain (1st gain: 1 V, 2nd gain: 2 V)																																																								
	0C	Completion of position reference (completed: 5 V not completed: 0 V)																																																								
	0D	Reserved (Do not change.)																																																								
	Reserved (Do not change.)																																																									
	Reserved (Do not change.)																																																									
	Pn008	Application Function Select Switch 8	0000 to 7121	–	4000	After restart	Setup	–																																																		
		<div style="display: flex; align-items: flex-start;"> <div style="margin-right: 20px;"> <p>n. <input type="checkbox"/> 4th digit</p> <p><input type="checkbox"/> 3rd digit</p> <p><input type="checkbox"/> 2nd digit</p> <p><input type="checkbox"/> 1st digit</p> </div> <table border="1" style="width: 100%; border-collapse: collapse;"> <tr><td colspan="3" style="background-color: #cccccc;">Reserved (Do not change.)</td></tr> <tr> <td colspan="2" style="text-align: right;"><b>Function Selection for Insufficient voltage</b></td> <td style="text-align: right;">(Refer to 4.2.11)</td> </tr> <tr><td>0</td><td>Disables detection of insufficient voltages.</td><td></td></tr> <tr><td>1</td><td>Detects warning and limits force by host controller.</td><td></td></tr> <tr><td>2</td><td>Detects warning and limits force by Pn424 and Pn425.</td><td></td></tr> <tr> <td colspan="2" style="text-align: right;"><b>Warning Detection Selection</b></td> <td style="text-align: right;">(Refer to 8.2.1)</td> </tr> <tr><td>0</td><td>Detects warning.</td><td></td></tr> <tr><td>1</td><td>Does not detect warning.</td><td></td></tr> <tr><td colspan="3" style="background-color: #cccccc;">Reserved (Do not change.)</td></tr> </table> </div>							Reserved (Do not change.)			<b>Function Selection for Insufficient voltage</b>		(Refer to 4.2.11)	0	Disables detection of insufficient voltages.		1	Detects warning and limits force by host controller.		2	Detects warning and limits force by Pn424 and Pn425.		<b>Warning Detection Selection</b>		(Refer to 8.2.1)	0	Detects warning.		1	Does not detect warning.		Reserved (Do not change.)																									
Reserved (Do not change.)																																																										
<b>Function Selection for Insufficient voltage</b>		(Refer to 4.2.11)																																																								
0		Disables detection of insufficient voltages.																																																								
1		Detects warning and limits force by host controller.																																																								
2		Detects warning and limits force by Pn424 and Pn425.																																																								
<b>Warning Detection Selection</b>		(Refer to 8.2.1)																																																								
0		Detects warning.																																																								
1		Does not detect warning.																																																								
Reserved (Do not change.)																																																										

Parameter No.	Name	Setting Range	Units	Factory Setting	When Enabled	Classification	Reference Section	
<b>Pn009</b>	Application Function Select Switch 9	0000 to 0111	–	0010	After restart	Tuning	–	
	Reserved (Do not change.)							
	Current Control Method Selection (Refer to 5.8.3)							
	0	Current control method 1						
	1	Current control method 2						
	Speed Detection Method Selection (Refer to 5.8.5)							
	0	Speed detection 1						
	1	Speed detection 2						
	Reserved (Do not change.)							
<b>Pn00B</b>	Application Function Select Switch B	0000 to 1111	–	0000	After restart	Setup	–	
	Parameter Display Selection (Refer to 2.3.1)							
	0	Setup parameters						
	1	All parameters						
	Alarm Gr.2 Stop Method Selection (Refer to 4.2.8)							
	0	Stops the linear servomotor by setting the speed reference to "0".						
	1	Same setting as Pn001.0 (Stops the linear servomotor by applying DB or by coasting)						
	Power Supply Method for Three-phase SERVOPACK (Refer to 3.1.4)							
	0	Three-phase power supply						
1	Single-phase power supply							
Reserved (Do not change.)								

Parameter No.	Name	Setting Range	Units	Factory Setting	When Enabled	Classification	Reference Section
Pn00C	Application Function Select Switch C	0000 to 0111	–	0000	After restart	Setup	–
	<b>Selection of Test without Motor</b> (Refer to 4.3.3)						
	0   Disables Test without motor.						
	1   Enables Test without motor.						
	Reserved (Do not change.)						
	<b>Encoder Type for Test without Motor</b> (Refer to 4.3.3)						
	0   Incremental linear scale						
	0   Absolute linear scale						
	Reserved (Do not change.)						
Pn00D	Application Function Select Switch D	0000 to 0001	–	0000	After restart	Setup	–
	<b>Stand-alone Mode (Test Operation) Selection</b>						
	0   Enables connection with the command option module.						
	1   Disables connection with the command option module.						
	Reserved (Do not change.)						
	Reserved (Do not change.)						
	Reserved (Do not change.)						
	Reserved (Do not change.)						
	Reserved (Do not change.)						
Pn010	Axis Address Selection	0000 to 007F	–	0001	After restart	Setup	–
Pn080	Application Function Select Switch 80	0000 to 1111	–	0000	After restart	Setup	–
	<b>Hall Sensor Selection</b>						
	0   Enables selection.						
	1   Disables selection.						
	<b>Motor Phase Selection</b>						
	0   Sets phase A lead as phase sequence of U, V, W.						
	1   Sets phase B lead as phase sequence of U, V, W.						
	Reserved (Do not change.)						
	<b>Calculation Method for Maximum Speed or Divided Output Pulses</b>						
0   Determines divided output pulses with fixed maximum speed.							
1   Determines maximum speed with fixed divided output pulses.							

9.1.2 Parameters

Parameter No.	Name	Setting Range	Units	Factory Setting	When Enabled	Classification	Reference Section															
<b>Pn100</b>	Speed Loop Gain	10 to 20000	0.1 Hz	400	Immediately	Tuning	5.8.1															
<b>Pn101</b>	Speed Loop Integral Time Constant	15 to 51200	0.01 ms	2000	Immediately	Tuning																
<b>Pn102</b>	Position Loop Gain	10 to 20000	0.1/s	400	Immediately	Tuning																
<b>Pn103</b>	Mass Ratio	0 to 20000	1%	100	Immediately	Tuning																
<b>Pn104</b>	2nd Speed Loop Gain	10 to 20000	0.1 Hz	400	Immediately	Tuning																
<b>Pn105</b>	2nd Speed Loop Integral Time Constant	15 to 51200	0.01 ms	2000	Immediately	Tuning																
<b>Pn106</b>	2nd Position Loop Gain	10 to 20000	0.1/s	400	Immediately	Tuning	5.9.1															
<b>Pn109</b>	Feedforward Gain	0 to 100	1%	0	Immediately	Tuning																
<b>Pn10A</b>	Feedforward Filter Time Constant	0 to 6400	0.01 ms	0	Immediately	Tuning																
<b>Pn10B</b>	Application Function for Gain Select Switch	0000 to 5334	–	0000	–	–	–															
	<table border="1"> <thead> <tr> <th colspan="2">Mode Switch Selection (Refer to 5.9.2)</th> <th>When Enabled</th> <th>Classification</th> </tr> </thead> <tbody> <tr> <td>0</td> <td>Uses internal force reference as the condition (Level setting: Pn10C).</td> <td rowspan="5">Immediately</td> <td rowspan="5">Setup</td> </tr> <tr> <td>1</td> <td>Uses speed reference as the condition (Level setting: Pn181).</td> </tr> <tr> <td>2</td> <td>Uses acceleration as the condition (Level setting: Pn182).</td> </tr> <tr> <td>3</td> <td>Uses position error pulse as the condition (Level setting: Pn10F).</td> </tr> <tr> <td>4</td> <td>No mode switch function available.</td> </tr> </tbody> </table>						Mode Switch Selection (Refer to 5.9.2)		When Enabled	Classification	0	Uses internal force reference as the condition (Level setting: Pn10C).	Immediately	Setup	1	Uses speed reference as the condition (Level setting: Pn181).	2	Uses acceleration as the condition (Level setting: Pn182).	3	Uses position error pulse as the condition (Level setting: Pn10F).	4	No mode switch function available.
	Mode Switch Selection (Refer to 5.9.2)		When Enabled	Classification																		
	0	Uses internal force reference as the condition (Level setting: Pn10C).	Immediately	Setup																		
	1	Uses speed reference as the condition (Level setting: Pn181).																				
	2	Uses acceleration as the condition (Level setting: Pn182).																				
	3	Uses position error pulse as the condition (Level setting: Pn10F).																				
	4	No mode switch function available.																				
	<table border="1"> <thead> <tr> <th colspan="2">Speed Loop Control Method</th> <th>When Enabled</th> <th>Classification</th> </tr> </thead> <tbody> <tr> <td>0</td> <td>PI control</td> <td rowspan="3">After restart</td> <td rowspan="3">Setup</td> </tr> <tr> <td>1</td> <td>I-P control</td> </tr> <tr> <td>2 and 3</td> <td>Reserved (Do not change.)</td> </tr> </tbody> </table>						Speed Loop Control Method		When Enabled	Classification	0	PI control	After restart	Setup	1	I-P control	2 and 3	Reserved (Do not change.)				
Speed Loop Control Method		When Enabled	Classification																			
0	PI control	After restart	Setup																			
1	I-P control																					
2 and 3	Reserved (Do not change.)																					
Reserved (Do not change.)																						
Reserved (Do not change.)																						
<b>Pn10C</b>	Mode Switch (force reference)	0 to 800	1%	200	Immediately	Tuning	5.9.2															
<b>Pn10F</b>	Mode Switch (position error pulse)	0 to 10000	1 reference unit	0	Immediately	Tuning																
<b>Pn11F</b>	Position Integral Time Constant	0 to 50000	0.1 ms	0	Immediately	Tuning	5.9.4															
<b>Pn121</b>	Friction Compensation Gain	10 to 1000	1%	100	Immediately	Tuning	5.8.2															
<b>Pn122</b>	2nd Gain for Friction Compensation	10 to 1000	1%	100	Immediately	Tuning																
<b>Pn123</b>	Friction Compensation Coefficient	0 to 100	1%	0	Immediately	Tuning																
<b>Pn124</b>	Friction Compensation Frequency Correction	-10000 to 10000	0.1 Hz	0	Immediately	Tuning																
<b>Pn125</b>	Friction Compensation Gain Correction	1 to 1000	1%	100	Immediately	Tuning																
<b>Pn131</b>	Gain Switching Time 1	0 to 65535	1 ms	0	Immediately	Tuning	5.8.1															
<b>Pn132</b>	Gain Switching Time 2	0 to 65535	1 ms	0	Immediately	Tuning																
<b>Pn135</b>	Gain Switching Waiting Time 1	0 to 65535	1 ms	0	Immediately	Tuning																
<b>Pn136</b>	Gain Switching Waiting Time 2	0 to 65535	1 ms	0	Immediately	Tuning																

Parameter No.	Name	Setting Range	Units	Factory Setting	When Enabled	Classification	Reference Section	
Pn139	Automatic Gain Changeover Related Switch 1	0000 to 0052	–	0000	Immediately	Tuning	–	
	<div style="display: flex; justify-content: space-around; align-items: flex-start;"> <div style="text-align: center;"> <p>4th digit</p> <input type="checkbox"/> </div> <div style="text-align: center;"> <p>3rd digit</p> <input type="checkbox"/> </div> <div style="text-align: center;"> <p>2nd digit</p> <input type="checkbox"/> </div> <div style="text-align: center;"> <p>1st digit</p> <input type="checkbox"/> </div> </div> <p>n.</p>							
			<b>Gain Switching Selection Switch*1</b>				(Refer to 5.8.1)	
			0	Manual gain switching Switches between 1st gain and 2nd gain using the gain switching reference from the Command Option Module.				
			1	Reserved (Do not change.)				
			2	Automatic gain switching pattern 1 Changes automatically 1st gain to 2nd gain when the switching condition A is satisfied. Changes automatically 2nd gain to 1st gain when the switching condition A is not satisfied.				
			<b>Gain Switching Condition A</b>				(Refer to 5.8.1)	
			0	Positioning completion signal (/COIN) ON				
			1	Positioning completion signal (/COIN) OFF				
			2	NEAR signal (/NEAR) ON				
		3	NEAR signal (/NEAR) OFF					
		4	No output for position reference filter and reference pulse input OFF					
		5	Position reference pulse input ON					
		Reserved (Do not change.)						
		Reserved (Do not change.)						
Pn13D	Current Gain Level	100 to 2000	1%	2000	Immediately	Tuning	5.8.4	
Pn140	Model Following Control Related Switch	0000 to 1121	–	0100	Immediately	Tuning	–	
	<div style="display: flex; justify-content: space-around; align-items: flex-start;"> <div style="text-align: center;"> <p>4th digit</p> <input type="checkbox"/> </div> <div style="text-align: center;"> <p>3rd digit</p> <input type="checkbox"/> </div> <div style="text-align: center;"> <p>2nd digit</p> <input type="checkbox"/> </div> <div style="text-align: center;"> <p>1st digit</p> <input type="checkbox"/> </div> </div> <p>n.</p>							
			<b>Model Following Control Selection</b>					
			0	Does not use model following control.				
			1	Uses model following control.				
			<b>Vibration Suppression Selection</b>					
			0	Does not perform vibration suppression.				
			1	Performs vibration suppression over the specified frequency.				
			2	Performs vibration suppression over two different kinds of frequencies.				
			<b>Vibration Suppression Adjustment Selection</b>				(Refer to 5.3.1, 5.4.1, 5.5.1, 5.7.1)	
		0	Does not adjust vibration suppression automatically using utility function.					
		1	Adjusts vibration suppression automatically using utility function.					
		<b>Selection of Speed Feedforward (VFF) / Force Feedforward (TFF)</b>				(Refer to 5.3.1, 5.4.1)		
		0	Does not use model following control together with speed/force feedforward together.					
		1	Uses model following control together with speed/force feedforward together.					
Pn141	Model Following Control Gain	10 to 20000	0.1/s	500	Immediately	Tuning	–	
Pn142	Model Following Control Gain Compensation	500 to 2000	0.1%	1000	Immediately	Tuning	–	

\*1. For details on this function, refer to the manual of the connected Command Option Module.

9.1.2 Parameters

Parameter No.	Name	Setting Range	Units	Factory Setting	When Enabled	Classification	Reference Section						
<b>Pn143</b>	Model Following Control Bias (Forward Direction)	0 to 10000	0.1%	1000	Immediately	Tuning	–						
<b>Pn144</b>	Model Following Control Bias (Reverse Direction)	0 to 10000	0.1%	1000	Immediately	Tuning	–						
<b>Pn145</b>	Vibration Suppression 1 Frequency A	10 to 2500	0.1 Hz	500	Immediately	Tuning	–						
<b>Pn146</b>	Vibration Suppression 1 Frequency B	10 to 2500	0.1 Hz	700	Immediately	Tuning	–						
<b>Pn147</b>	Model Following Control Speed Feedforward Compensation	0 to 10000	0.1%	1000	Immediately	Tuning	–						
<b>Pn148</b>	2nd Model Following Control Gain	10 to 20000	0.1/s	500	Immediately	Tuning	–						
<b>Pn149</b>	2nd Model Following Control Gain Compensation	500 to 2000	0.1%	1000	Immediately	Tuning	–						
<b>Pn14A</b>	Vibration Suppression 2 Frequency	10 to 2000	0.1 Hz	800	Immediately	Tuning	–						
<b>Pn14B</b>	Vibration Suppression 2 Compensation	10 to 1000	1%	100	Immediately	Tuning	–						
<b>Pn14F</b>	Reserved (Do not change.)	–	–	0011	–	–	–						
<b>Pn160</b>	Anti-Resonance Control Related Switch	0000 to 0011	–	0010	Immediately	Tuning	–						
	<table border="1"> <thead> <tr> <th colspan="2">Anti-Resonance Control Selection (Refer to 5.3.1, 5.4.1, 5.5.1, 5.7.1)</th> </tr> </thead> <tbody> <tr> <td>0</td> <td>Does not use anti-resonance control.</td> </tr> <tr> <td>1</td> <td>Uses anti-resonance control.</td> </tr> </tbody> </table>							Anti-Resonance Control Selection (Refer to 5.3.1, 5.4.1, 5.5.1, 5.7.1)		0	Does not use anti-resonance control.	1	Uses anti-resonance control.
	Anti-Resonance Control Selection (Refer to 5.3.1, 5.4.1, 5.5.1, 5.7.1)												
	0	Does not use anti-resonance control.											
	1	Uses anti-resonance control.											
<table border="1"> <thead> <tr> <th colspan="2">Anti-Resonance Control Adjustment Selection (Refer to 5.3.1, 5.4.1, 5.5.1, 5.7.1)</th> </tr> </thead> <tbody> <tr> <td>0</td> <td>Does not use adjust anti-resonance control automatically using the utility function.</td> </tr> <tr> <td>1</td> <td>Adjusts anti-resonance control automatically using the utility function.</td> </tr> </tbody> </table>							Anti-Resonance Control Adjustment Selection (Refer to 5.3.1, 5.4.1, 5.5.1, 5.7.1)		0	Does not use adjust anti-resonance control automatically using the utility function.	1	Adjusts anti-resonance control automatically using the utility function.	
Anti-Resonance Control Adjustment Selection (Refer to 5.3.1, 5.4.1, 5.5.1, 5.7.1)													
0	Does not use adjust anti-resonance control automatically using the utility function.												
1	Adjusts anti-resonance control automatically using the utility function.												
Reserved (Do not change.)													
Reserved (Do not change.)													
<b>Pn161</b>	Anti-Resonance Frequency	10 to 20000	0.1 Hz	1000	Immediately	Tuning	–						
<b>Pn162</b>	Anti-Resonance Gain Compensation	1 to 1000	1%	100	Immediately	Tuning	–						
<b>Pn163</b>	Anti-Resonance Damping Gain	0 to 300	1%	0	Immediately	Tuning	–						
<b>Pn164</b>	Anti-Resonance Filter Time Constant 1 Compensation	-1000 to 1000	0.01 ms	0	Immediately	Tuning	–						
<b>Pn165</b>	Anti-Resonance Filter Time Constant 2 Compensation	-1000 to 1000	0.01 ms	0	Immediately	Tuning	–						



Parameter No.	Name	Setting Range	Units	Factory Setting	When Enabled	Classification	Reference Section	
<b>Pn170</b>	Tuning-less Function Related Switch	0000 to 2411	–	1401	–	–	–	
	Tuning-less Function Selection (Refer to 5.2)				When Enabled	Classification		
	0	Tuning-less function disabled			After restart	Setup		
	1	Tuning-less function enabled						
	Control Method during Speed Control (Refer to 5.2)				When Enabled	Classification		
	0	Uses as speed control.			After restart	Setup		
	1	Uses as speed control and uses the host controller for position control.						
	Tuning-less Tuning Level (Refer to 5.2)				When Enabled	Classification		
	0 to 4	Sets tuning-less tuning level.			Immediately	Setup		
Tuning-less Load Level (Refer to 5.2)				When Enabled	Classification			
0 to 2	Sets tuning-less load level.			Immediately	Setup			
<b>Pn181</b>	Mode Switch (Speed Reference)	0 to 10000	1 mm/s	0	Immediately	Tuning	5.9.2	
<b>Pn182</b>	Mode Switch (Acceleration)	0 to 30000	1 mm/s <sup>2</sup>	0	Immediately	Tuning	5.9.2	
<b>Pn190</b>	Reserved (Do not change.)	–	–	0010	–	–	–	
<b>Pn200</b>	Reserved (Do not change.)	–	–	0100	–	–	–	
<b>Pn207</b>	Position Control Function Switch	0000 to 2210	–	0010	After restart	Setup	–	
	Reserved (Do not change.)							
	Reserved (Do not change.)							
	Reserved (Do not change.)							
COIN Output Timing								
0	Outputs when the position error absolute value is the same or less than the positioning completion width (Pn522).							
1	Outputs when the position error absolute value is the position completion width (Pn522) or less and the reference after position reference filtering is 0.							
2	When the absolute value of the position error is below the positioning completed width setting (Pn522), and the position reference input is 0.							
<b>Pn20E</b>	Electronic Gear Ratio (Numerator)	1 to 1073741824 (2 <sup>30</sup> )	1	4	After restart	Setup	4.2.4	
<b>Pn210</b>	Electronic Gear Ratio (Denominator)	1 to 1073741824 (2 <sup>30</sup> )	1	1	After restart	Setup		
<b>Pn216</b>	Reserved (Do not change.)	–	–	0	–	–	–	
<b>Pn217</b>	Reserved (Do not change.)	–	–	0	–	–	–	

9.1.2 Parameters

Parameter No.	Name	Setting Range	Units	Factory Setting	When Enabled	Classification	Reference Section														
<b>Pn281</b>	Encoder Output Resolution	1 to 4096	1 edge/pitch	20	After restart	Setup	–														
<b>Pn282</b>	Linear Scale Pitch	0 to 65536	0.01 μm	0	After restart	Setup	–														
<b>Pn300</b>	Reserved (Do not change.)	–	–	600	–	–	–														
<b>Pn301</b>	Reserved (Do not change.)	–	–	100	–	–	–														
<b>Pn302</b>	Reserved (Do not change.)	–	–	200	–	–	–														
<b>Pn303</b>	Reserved (Do not change.)	–	–	300	–	–	–														
<b>Pn305</b>	Soft Start Acceleration Time	0 to 10000	1 ms	0	Immediately	Setup	–														
<b>Pn306</b>	Soft Start Deceleration Time	0 to 10000	1 ms	0	Immediately	Setup															
<b>Pn307</b>	Reserved (Do not change.)	–	–	40	–	–	–														
<b>Pn310</b>	Vibration Detection Switch	0000 to 0002	–	0000	Immediately	Setup	–														
	<table border="1" style="margin-left: 20px;"> <tr> <td colspan="2">Vibration Detection Selection (Refer to 6.16)</td> </tr> <tr> <td>0</td> <td>No detection.</td> </tr> <tr> <td>1</td> <td>Outputs warning (A.911) when vibration is detected.</td> </tr> <tr> <td>2</td> <td>Outputs alarm (A.520) when vibration is detected.</td> </tr> <tr> <td colspan="2">Reserved (Do not change.)</td> </tr> <tr> <td colspan="2">Reserved (Do not change.)</td> </tr> <tr> <td colspan="2">Reserved (Do not change.)</td> </tr> </table>							Vibration Detection Selection (Refer to 6.16)		0	No detection.	1	Outputs warning (A.911) when vibration is detected.	2	Outputs alarm (A.520) when vibration is detected.	Reserved (Do not change.)		Reserved (Do not change.)		Reserved (Do not change.)	
	Vibration Detection Selection (Refer to 6.16)																				
	0	No detection.																			
	1	Outputs warning (A.911) when vibration is detected.																			
2	Outputs alarm (A.520) when vibration is detected.																				
Reserved (Do not change.)																					
Reserved (Do not change.)																					
Reserved (Do not change.)																					
<b>Pn311</b>	Vibration Detection Sensibility	50 to 500	1%	100	Immediately	Tuning	6.16														
<b>Pn324</b>	Mass Calculating Start Level	0 to 20000	1%	300	Immediately	Setup	–														
<b>Pn380</b>	Reserved (Do not change.)	–	–	10	–	–	–														
<b>Pn381</b>	Reserved (Do not change.)	–	–	20	–	–	–														
<b>Pn382</b>	Reserved (Do not change.)	–	–	30	–	–	–														
<b>Pn383</b>	JOG Speed	0 to 10000	1 mm/s	50	Immediately	Setup	6.3														
<b>Pn384</b>	Vibration Detection Level	0 to 5000	1 mm/s	10	Immediately	Tuning	6.16														
<b>Pn385</b>	Motor Max. Speed	1 to 100	100 mm/s	50	After restart	Setup	4.2.10														
<b>Pn400</b>	Reserved (Do not change.)	–	–	30	–	–	–														
<b>Pn401</b>	Force Reference Filter Time Constant	0 to 65535	0.01 ms	100	Immediately	Tuning	5.9.3														
<b>Pn404</b>	Forward External Force Limit	0 to 800	1%	100	Immediately	Setup	4.4.2														
<b>Pn405</b>	Reverse External Force Limit	0 to 800	1%	100	Immediately	Setup															
<b>Pn406</b>	Emergency Stop Force	0 to 800	1%	800	Immediately	Setup	4.2.3														

Parameter No.	Name	Setting Range	Units	Factory Setting	When Enabled	Classification	Reference Section	
<b>Pn408</b>	Force Related Function Switch	0000 to 1111	–	0000	–	–	–	
	<b>1st Step Notch Filter Selection (Refer to 5.9.3)</b>						When Enabled	Classification
	0	N/A					Immediately	Setup
	1	Uses 1st step notch filter for force reference.						
	<b>Speed Limit Selection</b>						When Enabled	Classification
	0	Uses the smaller value between motor max. speed and parameter Pn480 as speed limit value.					After restart	Setup
	1	Uses the smaller value between overspeed detection speed and parameter Pn480 as speed limit value.						
	<b>2nd Step Notch Filter Selection (Refer to 5.9.3)</b>						When Enabled	Classification
	0	N/A					Immediately	Setup
	1	Uses 2nd step notch filter for force reference.						
	<b>Friction Compensation Function Selection (Refer to 5.8.2)</b>						When Enabled	Classification
	0	Disables use friction compensation function.					Immediately	Setup
	1	Enables friction compensation function.						
	<b>Pn409</b>	1st Notch Filter Frequency	50 to 5000	1 Hz	5000	Immediately	Tuning	5.9.3
	<b>Pn40A</b>	1st Notch Filter Q Value	50 to 1000	0.01	70	Immediately	Tuning	
<b>Pn40B</b>	1st Notch Filter Depth	0 to 1000	0.001	0	Immediately	Tuning		
<b>Pn40C</b>	2nd Notch Filter Frequency	50 to 5000	1 Hz	5000	Immediately	Tuning		
<b>Pn40D</b>	2nd Notch Filter Q Value	50 to 1000	0.01	70	Immediately	Tuning		
<b>Pn40E</b>	2nd Notch Filter Depth	0 to 1000	0.001	0	Immediately	Tuning		
<b>Pn40F</b>	2nd Step 2nd Force Reference Filter Frequency	100 to 5000	1 Hz	5000	Immediately	Tuning	5.8.1	
<b>Pn410</b>	2nd Step 2nd Force Reference Filter Q Value	50 to 100	0.01	50	Immediately	Tuning		
<b>Pn412</b>	1st Step 2nd Force Reference Filter Time Constant	0 to 65535	0.01 ms	100	Immediately	Tuning	4.2.10	
<b>Pn423</b>	Reserved (Do not change.)	–	–	0000	–	–		
<b>Pn424</b>	Force Limit at Main Circuit Voltage Drop	0 to 100	1%	50	Immediately	Setup		
<b>Pn425</b>	Release Time for Force Limit at Main Circuit Voltage Drop	0 to 1000	1 ms	100	Immediately	Setup		
<b>Pn456</b>	Sweep Force Reference Amplitude	1 to 800	1%	15	Immediately	Tuning	6.19	

Parameter No.	Name	Setting Range	Units	Factory Setting	When Enabled	Classification	Reference Section								
<b>Pn460</b>	Notch Filter Adjustment Switch	0000 to 0101	–	0101	Immediately	Tuning	5.2.1 5.3.1 5.5.1								
	<p>4th digit   3rd digit   2nd digit   1st digit</p> <p>n. <input type="checkbox"/> <input type="checkbox"/> <input type="checkbox"/> <input type="checkbox"/></p> <p>Notch Filter Adjustment Selection 1</p> <table border="1"> <tr> <td>0</td> <td>Does not set the 1st step notch filter automatically using the utility function.</td> </tr> <tr> <td>1</td> <td>Sets the 1st step notch filter automatically using the utility function.</td> </tr> </table> <p>Reserved (Do not change.)</p> <p>Notch Filter Adjustment Selection 2</p> <table border="1"> <tr> <td>0</td> <td>Does not set the 2nd step notch filter automatically using the utility function.</td> </tr> <tr> <td>1</td> <td>Sets the 2nd step notch filter automatically using the utility function.</td> </tr> </table> <p>Reserved (Do not change.)</p>							0	Does not set the 1st step notch filter automatically using the utility function.	1	Sets the 1st step notch filter automatically using the utility function.	0	Does not set the 2nd step notch filter automatically using the utility function.	1	Sets the 2nd step notch filter automatically using the utility function.
	0	Does not set the 1st step notch filter automatically using the utility function.													
	1	Sets the 1st step notch filter automatically using the utility function.													
	0	Does not set the 2nd step notch filter automatically using the utility function.													
	1	Sets the 2nd step notch filter automatically using the utility function.													
	<b>Pn480</b>	Speed Limit during Force Control	0 to 10000	1 mm/s	10000	Immediately	Setup	–							
	<b>Pn481</b>	Polarity Detection Speed Loop Gain	10 to 20000	0.1 Hz	400	Immediately	Tuning	–							
	<b>Pn482</b>	Polarity Detection Speed Loop Integral Time Constant	15 to 51200	0.01 ms	3000	Immediately	Tuning	–							
	<b>Pn483</b>	Forward Force Limit	0 to 800	1%	30	Immediately	Setup	4.4.1							
<b>Pn484</b>	Reverse Force Limit	0 to 800	1%	30	Immediately	Setup									
<b>Pn485</b>	Polarity Detection Reference Speed	0 to 100	1 mm/s	20	Immediately	Setup	–								
<b>Pn486</b>	Polarity Detection Reference Accel/Decel Time	0 to 100	1 ms	25	Immediately	Tuning	–								
<b>Pn487</b>	Polarity Detection Constant Speed Time	0 to 300	1 ms	0	Immediately	Tuning	–								
<b>Pn488</b>	Polarity Detection Reference Waiting Time	50 to 500	1 ms	100	Immediately	Tuning	–								
<b>Pn48E</b>	Polarity Detection Range	1 to 65535	1 mm	10	Immediately	Tuning	–								
<b>Pn490</b>	Polarity Detection Load Level	0 to 20000	1%	100	Immediately	Tuning	–								
<b>Pn495</b>	Polarity Detection Confirmation Force Reference	0 to 200	1%	100	Immediately	Tuning	–								
<b>Pn498</b>	Polarity Detection Allowable Error Range	0 to 30	1 deg	10	Immediately	Tuning	–								
<b>Pn501</b>	Reserved (Do not change.)	–	–	10	–	–	–								
<b>Pn506</b>	Brake Reference - Servo OFF Delay Time	0 to 50	10 ms	0	Immediately	Setup	4.2.7								
<b>Pn508</b>	Waiting Time for Brake Signal When Motor Running	10 to 100	10 ms	50	Immediately	Setup									
<b>Pn509</b>	Instantaneous Power Cut Hold time	20 to 1000	1 ms	20	Immediately	Setup	4.2.9								

Parameter No.	Name	Setting Range	Units	Factory Setting	When Enabled	Classification	Reference Section	
<b>Pn50A</b>	Input Signal Selection 1	0000 to FFF1	–	1881	After restart	Setup	–	
	<div style="display: flex; align-items: center;"> <div style="margin-right: 10px;">n.</div> <div style="display: flex; flex-direction: column; gap: 5px;"> <div style="display: flex; align-items: center;"> <div style="width: 15px; height: 15px; border: 1px solid black; margin-right: 5px;"></div> <div style="font-size: 8px;">4th digit</div> </div> <div style="width: 15px; height: 15px; border: 1px solid black; margin-right: 5px;"></div> <div style="font-size: 8px;">3rd digit</div> </div> <div style="display: flex; flex-direction: column; gap: 5px;"> <div style="width: 15px; height: 15px; border: 1px solid black; margin-right: 5px;"></div> <div style="font-size: 8px;">2nd digit</div> </div> <div style="display: flex; flex-direction: column; gap: 5px;"> <div style="width: 15px; height: 15px; border: 1px solid black; margin-right: 5px;"></div> <div style="font-size: 8px;">1st digit</div> </div> </div>							
	Reserved (Do not change.)							
	Reserved (Do not change.)							
	Reserved (Do not change.)							
	P-OT Signal Mapping						(Refer to 4.2.3)	
	0		Valid when CN1-13 input signal is ON (L-level).					
	1		Valid when CN1-7 input signal is ON (L-level).					
	2		Valid when CN1-8 input signal is ON (L-level).					
	3		Valid when CN1-9 input signal is ON (L-level).					
	4		Valid when CN1-10 input signal is ON (L-level).					
	5		Valid when CN1-11 input signal is ON (L-level).					
	6		Valid when CN1-12 input signal is ON (L-level).					
	7		Forward run prohibited.					
	8		Forward run allowed.					
	9		Valid when CN1-13 input signal is OFF (H-level).					
	A		Valid when CN1-7 input signal is OFF (H-level).					
	B		Valid when CN1-8 input signal is OFF (H-level).					
C		Valid when CN1-9 input signal is OFF (H-level).						
D		Valid when CN1-10 input signal is OFF (H-level).						
E		Valid when CN1-11 input signal is OFF (H-level).						
F		Valid when CN1-12 input signal is OFF (H-level).						

Parameter No.	Name	Setting Range	Units	Factory Setting	When Enabled	Classification	Reference Section																																																				
<b>Pn50B</b>	Input Signal Selection 2	0000 to FFFF	–	8882	After restart	Setup	–																																																				
	<div style="display: flex; justify-content: space-around; align-items: flex-start;"> <div style="text-align: center;">             4th digit  <input type="checkbox"/> </div> <div style="text-align: center;">             3rd digit  <input type="checkbox"/> </div> <div style="text-align: center;">             2nd digit  <input type="checkbox"/> </div> <div style="text-align: center;">             1st digit  <input type="checkbox"/> </div> </div> <p>n. <input type="checkbox"/> <input type="checkbox"/> <input type="checkbox"/> <input type="checkbox"/></p>		<table border="1" style="width: 100%; border-collapse: collapse;"> <thead> <tr style="background-color: #cccccc;"> <th colspan="2">N-OT Signal Mapping</th> <th style="text-align: right;">(Refer to 4.2.3)</th> </tr> </thead> <tbody> <tr><td>0</td><td colspan="2">Valid when CN1-13 input signal is ON (L-level).</td></tr> <tr><td>1</td><td colspan="2">Valid when CN1-7 input signal is ON (L-level).</td></tr> <tr><td>2</td><td colspan="2">Valid when CN1-8 input signal is ON (L-level).</td></tr> <tr><td>3</td><td colspan="2">Valid when CN1-9 input signal is ON (L-level).</td></tr> <tr><td>4</td><td colspan="2">Valid when CN1-10 input signal is ON (L-level).</td></tr> <tr><td>5</td><td colspan="2">Valid when CN1-11 input signal is ON (L-level).</td></tr> <tr><td>6</td><td colspan="2">Valid when CN1-12 input signal is ON (L-level).</td></tr> <tr><td>7</td><td colspan="2">Reverse run prohibited.</td></tr> <tr><td>8</td><td colspan="2">Reverse run allowed.</td></tr> <tr><td>9</td><td colspan="2">Valid when CN1-13 input signal is OFF (H-level).</td></tr> <tr><td>A</td><td colspan="2">Valid when CN1-7 input signal is OFF (H-level).</td></tr> <tr><td>B</td><td colspan="2">Valid when CN1-8 input signal is OFF (H-level).</td></tr> <tr><td>C</td><td colspan="2">Valid when CN1-9 input signal is OFF (H-level).</td></tr> <tr><td>D</td><td colspan="2">Valid when CN1-10 input signal is OFF (H-level).</td></tr> <tr><td>E</td><td colspan="2">Valid when CN1-11 input signal is OFF (H-level).</td></tr> <tr><td>F</td><td colspan="2">Valid when CN1-12 input signal is OFF (H-level).</td></tr> </tbody> </table>						N-OT Signal Mapping		(Refer to 4.2.3)	0	Valid when CN1-13 input signal is ON (L-level).		1	Valid when CN1-7 input signal is ON (L-level).		2	Valid when CN1-8 input signal is ON (L-level).		3	Valid when CN1-9 input signal is ON (L-level).		4	Valid when CN1-10 input signal is ON (L-level).		5	Valid when CN1-11 input signal is ON (L-level).		6	Valid when CN1-12 input signal is ON (L-level).		7	Reverse run prohibited.		8	Reverse run allowed.		9	Valid when CN1-13 input signal is OFF (H-level).		A	Valid when CN1-7 input signal is OFF (H-level).		B	Valid when CN1-8 input signal is OFF (H-level).		C	Valid when CN1-9 input signal is OFF (H-level).		D	Valid when CN1-10 input signal is OFF (H-level).		E	Valid when CN1-11 input signal is OFF (H-level).		F	Valid when CN1-12 input signal is OFF (H-level).	
	N-OT Signal Mapping		(Refer to 4.2.3)																																																								
	0	Valid when CN1-13 input signal is ON (L-level).																																																									
	1	Valid when CN1-7 input signal is ON (L-level).																																																									
	2	Valid when CN1-8 input signal is ON (L-level).																																																									
	3	Valid when CN1-9 input signal is ON (L-level).																																																									
	4	Valid when CN1-10 input signal is ON (L-level).																																																									
	5	Valid when CN1-11 input signal is ON (L-level).																																																									
	6	Valid when CN1-12 input signal is ON (L-level).																																																									
7	Reverse run prohibited.																																																										
8	Reverse run allowed.																																																										
9	Valid when CN1-13 input signal is OFF (H-level).																																																										
A	Valid when CN1-7 input signal is OFF (H-level).																																																										
B	Valid when CN1-8 input signal is OFF (H-level).																																																										
C	Valid when CN1-9 input signal is OFF (H-level).																																																										
D	Valid when CN1-10 input signal is OFF (H-level).																																																										
E	Valid when CN1-11 input signal is OFF (H-level).																																																										
F	Valid when CN1-12 input signal is OFF (H-level).																																																										
		Reserved (Do not change.)																																																									
		/P-CL Signal Mapping																																																									
		0 to F   Same as N-OT signal mapping																																																									
		/N-CL Signal Mapping																																																									
		0 to F   Same as N-OT signal mapping																																																									
<b>Pn50C</b>	Reserved (Do not change.)	–	–	8888	–	–	–																																																				
<b>Pn50D</b>	Reserved (Do not change.)	–	–	8888	–	–	–																																																				

Parameter No.	Name	Setting Range	Units	Factory Setting	When Enabled	Classification	Reference Section											
Pn50E	Output Signal Selection 1	0000 to 3333	–	0000	After restart	Setup	3.3.2											
	<table border="1"> <tr> <th colspan="2">Positioning Completion Signal Mapping (/COIN)</th> </tr> <tr> <td>0</td> <td>Disabled (the above signal is not used.)</td> </tr> <tr> <td>1</td> <td>Outputs the signal from CN1-1, 2 output terminal.</td> </tr> <tr> <td>2</td> <td>Outputs the signal from CN1-23, 24 output terminal.</td> </tr> <tr> <td>3</td> <td>Outputs the signal from CN1-25, 26 output terminal.</td> </tr> </table>								Positioning Completion Signal Mapping (/COIN)		0	Disabled (the above signal is not used.)	1	Outputs the signal from CN1-1, 2 output terminal.	2	Outputs the signal from CN1-23, 24 output terminal.	3	Outputs the signal from CN1-25, 26 output terminal.
	Positioning Completion Signal Mapping (/COIN)																	
	0	Disabled (the above signal is not used.)																
	1	Outputs the signal from CN1-1, 2 output terminal.																
	2	Outputs the signal from CN1-23, 24 output terminal.																
	3	Outputs the signal from CN1-25, 26 output terminal.																
	<table border="1"> <tr> <th colspan="2">Speed Coincidence Detection Signal Mapping (/V-CMP) <span style="float:right">(Refer to 4.6.3)</span></th> </tr> <tr> <td>0 to 3</td> <td>Same as /COIN</td> </tr> </table>								Speed Coincidence Detection Signal Mapping (/V-CMP) <span style="float:right">(Refer to 4.6.3)</span>		0 to 3	Same as /COIN						
	Speed Coincidence Detection Signal Mapping (/V-CMP) <span style="float:right">(Refer to 4.6.3)</span>																	
0 to 3	Same as /COIN																	
<table border="1"> <tr> <th colspan="2">Servomotor Movement Detection Signal Mapping (/TGON)</th> </tr> <tr> <td>0 to 3</td> <td>Same as /COIN</td> </tr> </table>								Servomotor Movement Detection Signal Mapping (/TGON)		0 to 3	Same as /COIN							
Servomotor Movement Detection Signal Mapping (/TGON)																		
0 to 3	Same as /COIN																	
<table border="1"> <tr> <th colspan="2">Servo Ready Signal Mapping (/S-RDY) <span style="float:right">(Refer to 4.6.4)</span></th> </tr> <tr> <td>0 to 3</td> <td>Same as /COIN</td> </tr> </table>								Servo Ready Signal Mapping (/S-RDY) <span style="float:right">(Refer to 4.6.4)</span>		0 to 3	Same as /COIN							
Servo Ready Signal Mapping (/S-RDY) <span style="float:right">(Refer to 4.6.4)</span>																		
0 to 3	Same as /COIN																	
Pn50F	Output Signal Selection 2	0000 to 3333	–	0100	After restart	Setup	3.3.2											
	<table border="1"> <tr> <th colspan="2">Force Limit Detection Signal Mapping (/CLT)</th> </tr> <tr> <td>0</td> <td>Disabled (the above signal is not used.)</td> </tr> <tr> <td>1</td> <td>Outputs the signal from CN1-1, 2 output terminal.</td> </tr> <tr> <td>2</td> <td>Outputs the signal from CN1-23, 24 output terminal.</td> </tr> <tr> <td>3</td> <td>Outputs the signal from CN1-25, 26 output terminal.</td> </tr> </table>								Force Limit Detection Signal Mapping (/CLT)		0	Disabled (the above signal is not used.)	1	Outputs the signal from CN1-1, 2 output terminal.	2	Outputs the signal from CN1-23, 24 output terminal.	3	Outputs the signal from CN1-25, 26 output terminal.
	Force Limit Detection Signal Mapping (/CLT)																	
	0	Disabled (the above signal is not used.)																
	1	Outputs the signal from CN1-1, 2 output terminal.																
	2	Outputs the signal from CN1-23, 24 output terminal.																
	3	Outputs the signal from CN1-25, 26 output terminal.																
	<table border="1"> <tr> <th colspan="2">Speed Limit Detection Signal Mapping (/VLT)</th> </tr> <tr> <td>0 to 3</td> <td>Same as /CLT</td> </tr> </table>								Speed Limit Detection Signal Mapping (/VLT)		0 to 3	Same as /CLT						
	Speed Limit Detection Signal Mapping (/VLT)																	
0 to 3	Same as /CLT																	
<table border="1"> <tr> <th colspan="2">Brake Signal Mapping (/BK)</th> </tr> <tr> <td>0 to 3</td> <td>Same as /CLT</td> </tr> </table>								Brake Signal Mapping (/BK)		0 to 3	Same as /CLT							
Brake Signal Mapping (/BK)																		
0 to 3	Same as /CLT																	
<table border="1"> <tr> <th colspan="2">Warning Signal Mapping (/WARN)</th> </tr> <tr> <td>0 to 3</td> <td>Same as /CLT</td> </tr> </table>								Warning Signal Mapping (/WARN)		0 to 3	Same as /CLT							
Warning Signal Mapping (/WARN)																		
0 to 3	Same as /CLT																	

Parameter No.	Name	Setting Range	Units	Factory Setting	When Enabled	Classification	Reference Section																
<b>Pn510</b>	Output Signal Selection 3	0000 to 0033	–	0000	After restart	Setup	–																
	<div style="display: flex; align-items: flex-start;"> <div style="margin-right: 20px;"> <p>n. <input type="checkbox"/> <input type="checkbox"/> <input type="checkbox"/> <input type="checkbox"/></p> <p style="margin-left: 10px;">4th digit   3rd digit   2nd digit   1st digit</p> </div> <table border="1" style="border-collapse: collapse;"> <tr> <th colspan="2">Near Signal Mapping (/NEAR)</th> </tr> <tr> <td style="text-align: center;">0</td> <td>Disabled (the above signal is not used.)</td> </tr> <tr> <td style="text-align: center;">1</td> <td>Outputs the signal from CN1-1, -2 terminal.</td> </tr> <tr> <td style="text-align: center;">2</td> <td>Outputs the signal from CN1-23, -24 terminal.</td> </tr> <tr> <td style="text-align: center;">3</td> <td>Outputs the signal from CN1-25, -26 terminal.</td> </tr> <tr> <td colspan="2">Reserved (Do not change.)</td> </tr> <tr> <td colspan="2">Reserved (Do not change.)</td> </tr> <tr> <td colspan="2">Reserved (Do not change.)</td> </tr> </table> </div>							Near Signal Mapping (/NEAR)		0	Disabled (the above signal is not used.)	1	Outputs the signal from CN1-1, -2 terminal.	2	Outputs the signal from CN1-23, -24 terminal.	3	Outputs the signal from CN1-25, -26 terminal.	Reserved (Do not change.)		Reserved (Do not change.)		Reserved (Do not change.)	
	Near Signal Mapping (/NEAR)																						
	0	Disabled (the above signal is not used.)																					
	1	Outputs the signal from CN1-1, -2 terminal.																					
2	Outputs the signal from CN1-23, -24 terminal.																						
3	Outputs the signal from CN1-25, -26 terminal.																						
Reserved (Do not change.)																							
Reserved (Do not change.)																							
Reserved (Do not change.)																							



Parameter No.	Name	Setting Range	Units	Factory Setting	When Enabled	Classification	Reference Section	
<b>Pn511</b>	Input Signal Selection 5	0000 to FFFF	–	6543	After restart	Setup	–	
	<div style="display: flex; justify-content: space-around; align-items: center;"> <div style="text-align: center;">4th digit <input type="checkbox"/></div> <div style="text-align: center;">3rd digit <input type="checkbox"/></div> <div style="text-align: center;">2nd digit <input type="checkbox"/></div> <div style="text-align: center;">1st digit <input type="checkbox"/></div> </div> <p>n.</p>							
			<b>Input Signal 3 Mapping for Command Option Module (/SI3)</b>					
			0	Inputs the signal from CN1-13 input terminal.				
			1	Inputs the signal from CN1-7 input terminal.				
			2	Inputs the signal from CN1-8 input terminal.				
			3	Inputs the signal from CN1-9 input terminal.				
			4	Inputs the signal from CN1-10 input terminal.				
			5	Inputs the signal from CN1-11 input terminal.				
			6	Inputs the signal from CN1-12 input terminal.				
		7	Sets signal ON.					
		8	Sets signal OFF.					
		9	Inputs the reverse signal from CN1-13 input terminal.					
		A	Inputs the reverse signal from CN1-7 input terminal.					
		B	Inputs the reverse signal from CN1-8 input terminal.					
		C	Inputs the reverse signal from CN1-9 input terminal.					
		D	Inputs the reverse signal from CN1-10 input terminal.					
		E	Inputs the reverse signal from CN1-11 input terminal.					
		F	Inputs the reverse signal from CN1-12 input terminal.					
		<b>Input Signal 4 Mapping for Command Option Module (/SI4)</b>						
		4	Inputs the signal from CN1-10 input terminal.					
		5	Inputs the signal from CN1-11 input terminal.					
		6	Inputs the signal from CN1-12 input terminal.					
		7	Sets signal ON.					
		8	Sets signal OFF.					
		D	Inputs the reverse signal from CN1-10 input terminal.					
		E	Inputs the reverse signal from CN1-11 input terminal.					
		F	Inputs the reverse signal from CN1-12 input terminal.					
		0 to 3 9 to F	Sets signal OFF.					
		<b>Input Signal 5 Mapping for Command Option Module (/SI5)</b>						
		0 to F	Same as /SI4 signal mapping.					
		<b>Input Signal 6 Mapping for Command Option Module (/SI6)</b>						
		0 to F	Same as /SI4 signal mapping.					

Parameter No.	Name	Setting Range	Units	Factory Setting	When Enabled	Classification	Reference Section						
<b>Pn512</b>	Output Signal Inverse Setting	0000 to 0111	–	0000	After restart	Setup	3.3.2						
	<table border="1"> <thead> <tr> <th colspan="2">Output Signal Inversion for CN1-1 or -2 Terminals</th> </tr> </thead> <tbody> <tr> <td>0</td> <td>Does not invert outputs.</td> </tr> <tr> <td>1</td> <td>Inverts outputs.</td> </tr> </tbody> </table>							Output Signal Inversion for CN1-1 or -2 Terminals		0	Does not invert outputs.	1	Inverts outputs.
	Output Signal Inversion for CN1-1 or -2 Terminals												
	0	Does not invert outputs.											
	1	Inverts outputs.											
	<table border="1"> <thead> <tr> <th colspan="2">Output Signal Inversion for CN1-23 or -24 Terminals</th> </tr> </thead> <tbody> <tr> <td>0</td> <td>Does not invert outputs.</td> </tr> <tr> <td>1</td> <td>Inverts outputs.</td> </tr> </tbody> </table>							Output Signal Inversion for CN1-23 or -24 Terminals		0	Does not invert outputs.	1	Inverts outputs.
	Output Signal Inversion for CN1-23 or -24 Terminals												
	0	Does not invert outputs.											
	1	Inverts outputs.											
<table border="1"> <thead> <tr> <th colspan="2">Output Signal Inversion for CN1-25 or -26 Terminals</th> </tr> </thead> <tbody> <tr> <td>0</td> <td>Does not invert outputs.</td> </tr> <tr> <td>1</td> <td>Inverts outputs.</td> </tr> </tbody> </table>							Output Signal Inversion for CN1-25 or -26 Terminals		0	Does not invert outputs.	1	Inverts outputs.	
Output Signal Inversion for CN1-25 or -26 Terminals													
0	Does not invert outputs.												
1	Inverts outputs.												
<table border="1"> <thead> <tr> <th colspan="2">Reserved (Do not change.)</th> </tr> </thead> <tbody> <tr> <td>0</td> <td>Does not invert outputs.</td> </tr> <tr> <td>1</td> <td>Inverts outputs.</td> </tr> </tbody> </table>							Reserved (Do not change.)		0	Does not invert outputs.	1	Inverts outputs.	
Reserved (Do not change.)													
0	Does not invert outputs.												
1	Inverts outputs.												
<b>Pn513</b>	Reserved Parameter (Do not change.)	–	–	0000	–	–	–						
<b>Pn517</b>	Reserved Parameter (Do not change.)	–	–	0000	–	–	–						
<b>Pn51E</b>	Excessive Position Error Warning Level	10 to 100	1%	100	Immediately	Setup	8.2.1						
<b>Pn520</b>	Excessive Position Error Alarm Level	1 to 1073741823 ( $2^{30}-1$ )	1 reference unit	5242880	Immediately	Setup	5.1.4 8.1.1						
<b>Pn522</b>	Positioning Completed Width	0 to 1073741824 ( $2^{30}$ )	1 reference unit	7	Immediately	Setup	–						
<b>Pn524</b>	NEAR Signal Width	1 to 1073741824 ( $2^{30}$ )	1 reference unit	1073741824	Immediately	Setup	–						
<b>Pn526</b>	Excessive Position Error Alarm Level at Servo ON	1 to 1073741823 ( $2^{30}-1$ )	1 reference unit	5242880	Immediately	Setup	5.1.4 8.1.1						
<b>Pn528</b>	Excessive Position Error Warning Level at Servo ON	10 to 100	1%	100	Immediately	Setup	8.2.1						
<b>Pn52B</b>	Overload Warning Level	1 to 100	1%	20	Immediately	Setup	4.2.12						
<b>Pn52C</b>	Derating of Base Current at Detecting Overload of Motor	10 to 100	1%	100	After restart	Setup							
<b>Pn52F</b>	Monitor Display at Power ON	0000 to 0FFF	–	0FFF	Immediately	Setup							

Parameter No.	Name	Setting Range	Units	Factory Setting	When Enabled	Classification	Reference Section																				
<b>Pn530</b>	Program JOG Operation Related Switch	0000 to 0005	–	0000	Immediately	Setup	6.5																				
	<table border="1" style="margin-left: 20px;"> <thead> <tr> <th colspan="2">Program JOG Operation Related Switch</th> </tr> </thead> <tbody> <tr> <td>0</td> <td>(Waiting time Pn535 → Forward movement Pn531) × Number of times of movement Pn536</td> </tr> <tr> <td>1</td> <td>(Waiting time Pn535 → Reverse movement Pn531) × Number of times of movements Pn536</td> </tr> <tr> <td>2</td> <td>(Waiting time Pn535 → Forward movement Pn531) × Number of times of movements Pn536 (Waiting time Pn535 → Reverse movement Pn531) × Number of times of movements Pn536</td> </tr> <tr> <td>3</td> <td>(Waiting time Pn535 → Reverse movement Pn531) × Number of times of movements Pn536 (Waiting time Pn535 → Forward movement Pn531) × Number of times of movements Pn536</td> </tr> <tr> <td>4</td> <td>(Waiting time Pn535 → Forward movement Pn531 → Waiting time Pn535 → Reverse movement Pn531) × Number of times of movement Pn536</td> </tr> <tr> <td>5</td> <td>(Waiting time Pn535 → Reverse movement Pn531 → Waiting time Pn535 → Forward movement Pn531) × Number of times of movement Pn536</td> </tr> <tr> <td colspan="2">Reserved (Do not change.)</td> </tr> <tr> <td colspan="2">Reserved (Do not change.)</td> </tr> <tr> <td colspan="2">Reserved (Do not change.)</td> </tr> </tbody> </table>							Program JOG Operation Related Switch		0	(Waiting time Pn535 → Forward movement Pn531) × Number of times of movement Pn536	1	(Waiting time Pn535 → Reverse movement Pn531) × Number of times of movements Pn536	2	(Waiting time Pn535 → Forward movement Pn531) × Number of times of movements Pn536 (Waiting time Pn535 → Reverse movement Pn531) × Number of times of movements Pn536	3	(Waiting time Pn535 → Reverse movement Pn531) × Number of times of movements Pn536 (Waiting time Pn535 → Forward movement Pn531) × Number of times of movements Pn536	4	(Waiting time Pn535 → Forward movement Pn531 → Waiting time Pn535 → Reverse movement Pn531) × Number of times of movement Pn536	5	(Waiting time Pn535 → Reverse movement Pn531 → Waiting time Pn535 → Forward movement Pn531) × Number of times of movement Pn536	Reserved (Do not change.)		Reserved (Do not change.)		Reserved (Do not change.)	
	Program JOG Operation Related Switch																										
	0	(Waiting time Pn535 → Forward movement Pn531) × Number of times of movement Pn536																									
	1	(Waiting time Pn535 → Reverse movement Pn531) × Number of times of movements Pn536																									
	2	(Waiting time Pn535 → Forward movement Pn531) × Number of times of movements Pn536 (Waiting time Pn535 → Reverse movement Pn531) × Number of times of movements Pn536																									
	3	(Waiting time Pn535 → Reverse movement Pn531) × Number of times of movements Pn536 (Waiting time Pn535 → Forward movement Pn531) × Number of times of movements Pn536																									
	4	(Waiting time Pn535 → Forward movement Pn531 → Waiting time Pn535 → Reverse movement Pn531) × Number of times of movement Pn536																									
	5	(Waiting time Pn535 → Reverse movement Pn531 → Waiting time Pn535 → Forward movement Pn531) × Number of times of movement Pn536																									
	Reserved (Do not change.)																										
Reserved (Do not change.)																											
Reserved (Do not change.)																											
<b>Pn531</b>	Program JOG Movement Distance	1 to 1073741824 (2 <sup>30</sup> )	1 reference unit	32768	Immediately	Setup	6.5																				
<b>Pn534</b>	Program JOG Acceleration/Deceleration Time	2 to 10000	1 ms	100	Immediately	Setup																					
<b>Pn535</b>	Program JOG Waiting Time	0 to 10000	1 ms	100	Immediately	Setup																					
<b>Pn536</b>	Number of Times of Program JOG Movement	0 to 1000	1 time	1	Immediately	Setup																					
<b>Pn550</b>	Analog Monitor 1 Offset Voltage	-10000 to 10000	0.1 V	0	Immediately	Setup	5.1.3																				
<b>Pn551</b>	Analog Monitor 2 Offset Voltage	-10000 to 10000	0.1 V	0	Immediately	Setup																					
<b>Pn552</b>	Analog Monitor Magnification (×1)	-10000 to 10000	×0.01	100	Immediately	Setup																					
<b>Pn553</b>	Analog Monitor Magnification (×2)	-10000 to 10000	×0.01	100	Immediately	Setup																					
<b>Pn560</b>	Remained Vibration Detection Width	1 to 3000	0.1%	400	Immediately	Setup	5.7.1																				
<b>Pn561</b>	Overshoot Detection Level	0 to 100	1%	100	Immediately	Setup	5.3.1 5.4.1																				
<b>Pn580</b>	Reserved (Do not change.)	–	–	10	–	–	–																				
<b>Pn581</b>	Zero Speed Level	0 to 10000	1 mm/s	20	Immediately	Setup	–																				
<b>Pn582</b>	Speed Coincidence Signal Output Width	0 to 100	1 mm/s	10	Immediately	Setup	–																				
<b>Pn583</b>	Brake Reference Output Speed Level	0 to 10000	1 mm/s	10	Immediately	Setup	4.2.6																				
<b>Pn584</b>	Speed Limit Level at Servo ON	0 to 10000	1 mm/s	10000	Immediately	Setup	8.1.1																				
<b>Pn585</b>	Program JOG Movement Speed	1 to 10000	1 mm/s	50	Immediately	Setup	6.5																				
<b>Pn586</b>	Motor Running Air-cooling Ratio	0 to 100	1%/maxvel	0	Immediately	Setup	–																				

Parameter No.	Name	Setting Range	Units	Factory Setting	When Enabled	Classification	Reference Section				
<b>Pn587</b>	Polarity Detection for Absolute Scale Selection	0000 to 0001	–	0000	Immediately	Setup	–				
	<p>4th digit   3rd digit   2nd digit   1st digit</p> <p>n. <input type="checkbox"/> <input type="checkbox"/> <input type="checkbox"/> <input type="checkbox"/></p> <p>Polarity Detection for Absolute Scale Selection</p> <table border="1"> <tr> <td>0</td> <td>Does not detect polarity.</td> </tr> <tr> <td>1</td> <td>Detects polarity.</td> </tr> </table> <p>Reserved (Do not change.)</p> <p>Reserved (Do not change.)</p> <p>Reserved (Do not change.)</p>							0	Does not detect polarity.	1	Detects polarity.
	0	Does not detect polarity.									
	1	Detects polarity.									
	<b>Pn600</b>	Regenerative Resistor Capacity *2	Depends on SERVOPACK Capacity *3	10 W	0	Immediately	Setup	3.7.2			
<b>Pn601</b>	Reserved (Do not change.)	–	–	0	–	–	–				
<b>Pn800 to Pn95F</b> 4	Reserved (Do not change.)	–	–	0	–	–	–				

\*2. Normally set to “0.” When using an external regenerative resistor, set the capacity (W) of the regenerative resistor.

\*3. The upper limit is the maximum output capacity (W) of the SERVOPACK.

\*4. For details on Pn800 to Pn95F, refer to the manual of the connected Command Option Module.

## 9.2 Monitor Modes

The following list shows monitor modes available.

Parameter No.	Content of Display	Unit
Un000	Motor movement speed	mm/s
Un001	Speed reference (for speed control)	mm/s
Un002	Internal force reference (in percentage to the rated force)	%
Un003	Electric angle 1	pulse (linear scale resolution)
Un004	Electric angle 2 (angle from the polarity origin)	deg
Un005	Input signal monitor	–
Un006	Output signal monitor	–
Un007	Reference speed (for position control)	mm/s
Un008	Position error (for position control)	reference unit
Un009	Accumulated load ratio (in percentage to the rated force: effective force in cycle of 10 seconds)	%
Un00A	Regenerative load ratio (in percentage to the processable regenerative power: regenerative power consumption in cycle of 10 seconds)	%
Un00B	Power consumed by DB resistance (in percentage to the processable power at DB activation: displayed in cycle of 10 seconds)	%
Un00C	Reference counter	reference unit
Un00D	Feedback pulse counter	pulse (linear scale resolution) <sup>*1</sup>
Un010	Maximum allowable motor speed or maximum allowable encoder output resolution	–
Un011	Hall sensor signal monitor	–
Un012	Total operation time	100 ms
Un013	Feedback pulse counter	reference unit
Un014	Effective gain monitor (gain setting 1 = 1, gain setting 2 = 2)	–
Un015	Safety I/O signal monitor	–
Un020	Motor rated speed	mm/s
Un021	Motor maximum speed	mm/s
Un084	Linear scale pitch <sup>*2</sup>	µm
Un085	Linear scale pitch index <sup>*2</sup>	–

\*1. For details, refer to 4.2.4 *Electronic Gear*.

\*2. Scale pitch =  $Un084 \times 10^{Un085}$  [µm]

## 9.3 Parameter Recording Table

Use the following table for recording parameters.

Note: Pn10B, Pn170 and Pn408 have two kinds of digits: the digit which does not need the restart after changing the settings and the digit which needs the restart. The underlined digits of the factory setting in the following table show the digit which needs the restart. Pn4

Parameter	Factory Setting					Name	When Enabled
Pn000	0000					Basic Function Select Switch 0	After restart
Pn001	0000					Application Function Select Switch 1	After restart
Pn002	0000					Application Function Select Switch 2	After restart
Pn006	0002					Application Function Select Switch 6	Immediately
Pn007	0000					Application Function Select Switch 7	Immediately
Pn008	4000					Application Function Select Switch 8	After restart
Pn009	0010					Application Function Select Switch 9	After restart
Pn00B	0000					Application Function Select Switch B	After restart
Pn00C	0000					Application Function Select Switch C	After restart
Pn00D	0000					Application Function Select Switch D	After restart
Pn010	0001					Axis Address Selection (for UART/USB communications)	After restart
Pn080	0000					Application Function Select Switch 80	After restart
Pn100	40.0 Hz					Speed Loop Gain	Immediately
Pn101	20.00 ms					Speed Loop Integral Time Constant	Immediately
Pn102	40.0/s					Position Loop Gain	Immediately
Pn103	100 %					Mass Ratio	Immediately
Pn104	40.0 Hz					2nd Speed Loop Gain	Immediately
Pn105	20.00 ms					2nd Speed Loop Integral Time Constant	Immediately
Pn106	40.0/s					2nd Position Loop Gain	Immediately
Pn109	0 %					Feedforward Gain	Immediately
Pn10A	0.00 ms					Feedforward Filter Time Constant	Immediately
Pn10B	<u>0000</u>					Application Function for Gain Select Switch	–
Pn10C	200 %					Mode Switch (force reference)	Immediately
Pn10F	0 reference unit					Mode Switch (position error pulse)	Immediately
Pn11F	0.0 ms					Position Integral Time Constant	Immediately
Pn121	100%					Friction Compensation Gain	Immediately
Pn122	100%					2nd Gain for Friction Compensation	Immediately
Pn123	0%					Friction Compensation Coefficient	Immediately
Pn124	0.0 Hz					Friction Compensation Frequency Correction	Immediately
Pn125	100%					Friction Compensation Gain Correction	Immediately
Pn131	0 ms					Gain Switching Time 1	Immediately
Pn132	0 ms					Gain Switching Time 2	Immediately
Pn135	0 ms					Gain Switching Waiting Time 1	Immediately
Pn136	0 ms					Gain Switching Waiting Time 2	Immediately
Pn139	0000					Automatic Gain Changeover Related Switch 1	Immediately

Parameter	Factory Setting					Name	When Enabled
Pn13D	2000%					Current Gain Level	Immediately
Pn140	0100					Model Following Control Related Switch	Immediately
Pn141	50.0/s					Model Following Control Gain	Immediately
Pn142	100.0%					Model Following Control Gain Compensation	Immediately
Pn143	100.0%					Model Following Control Bias (Forward Direction)	Immediately
Pn144	100.0%					Model Following Control Bias (Reverse Direction)	Immediately
Pn145	50.0 Hz					Vibration Suppression 1 Frequency A	Immediately
Pn146	70.0 Hz					Vibration Suppression 1 Frequency B	Immediately
Pn147	100.0%					Model Following Control Speed Feedforward Compensation	Immediately
Pn148	50.0/s					2nd Model Following Control Gain	Immediately
Pn149	100.0%					2nd Model Following Control Gain Compensation	Immediately
Pn14A	80.0 Hz					Vibration Suppression 2 Frequency	Immediately
Pn14B	100%					Vibration Suppression 2 Compensation	Immediately
Pn14F	0011					Reserved Parameter	–
Pn160	0010					Anti-Resonance Control Related Switch	Immediately
Pn161	100.0 Hz					Anti-Resonance Frequency	Immediately
Pn162	100%					Anti-Resonance Gain Compensation	Immediately
Pn163	0%					Anti-Resonance Damping Gain	Immediately
Pn164	0.00 ms					Anti-Resonance Filter Time Constant 1 Compensation	Immediately
Pn165	0.00 ms					Anti-Resonance Filter Time Constant 2 Compensation	Immediately
Pn170	1401					Tuning-less Function Related Switch	–
Pn181	0 mm/s					Mode Switch (Speed Reference)	Immediately
Pn182	0 mm/s <sup>2</sup>					Mode Switch (Acceleration)	Immediately
Pn190	0010					Reserved Parameter	–
Pn200	0100					Reserved Parameter	–
Pn207	0010					Position Control Function Switch	After restart
Pn20E	4					Electronic Gear Ratio (Numerator)	After restart
Pn210	1					Electronic Gear Ratio (Denominator)	After restart
Pn216	0					Reserved Parameter	–
Pn217	0					Reserved Parameter	–
Pn281	1 pulse/pitch					Encoder Output Resolution	After restart
Pn282	0.00 μm					Linear Scale Pitch	After restart
Pn300	600					Reserved Parameter	–
Pn301	100					Reserved Parameter	–
Pn302	200					Reserved Parameter	–
Pn303	300					Reserved Parameter	–
Pn305	0 ms					Soft Start Acceleration Time	Immediately
Pn306	0 ms					Soft Start Deceleration Time	Immediately
Pn307	40					Reserved Parameter	–

Parameter	Factory Setting					Name	When Enabled
Pn310	0000					Vibration Detection Switch	Immediately
Pn311	100%					Vibration Detection Sensibility	Immediately
Pn324	300%					Mass Calculating Start Level	Immediately
Pn380	10 mm/s					Reserved Parameter	Immediately
Pn381	20 mm/s					Reserved Parameter	Immediately
Pn382	30 mm/s					Reserved Parameter	Immediately
Pn383	50 mm/s					JOG Speed	Immediately
Pn384	10 mm/s					Vibration Detection Level	Immediately
Pn385	5000 mm/s					Motor Max. Speed	After restart
Pn400	30					Reserved Parameter	–
Pn401	1.00 ms					Force Reference Filter Time Constant	Immediately
Pn404	100%					Forward External Force Limit	Immediately
Pn405	100%					Reverse External Force Limit	Immediately
Pn406	800%					Emergency Stop Force	Immediately
Pn408	0000					Force Related Function Switch	–
Pn409	5000 Hz					1st Notch Filter Frequency	Immediately
Pn40A	0.70					1st Notch Filter Q Value	Immediately
Pn40B	0.000					1st Notch Filter Depth	Immediately
Pn40C	5000 Hz					2nd Notch Filter Frequency	Immediately
Pn40D	0.70					2nd Notch Filter Q Value	Immediately
Pn40E	0.000					2nd Notch Filter Depth	Immediately
Pn40F	5000 Hz					2nd Step 2nd Force Reference Filter Frequency	Immediately
Pn410	0.50					2nd Step 2nd Force Reference Filter Q Value	Immediately
Pn412	1.00 ms					1st Step 2nd Force Reference Filter Time Constant	Immediately
Pn423	0000					Reserved Parameter	–
Pn424	50%					Force Limit at Main Circuit Voltage Drop	Immediately
Pn425	100 ms					Release Time for Force Limit at Main Circuit Voltage Drop	Immediately
Pn456	15%					Sweep Force Reference Amplitude	Immediately
Pn460	0101					Notch Filter Adjustment Switch	Immediately
Pn480	10000 mm/s					Speed Limit during Force Control	Immediately
Pn481	4.00 Hz					Polarity Detection Speed Loop Gain	Immediately
Pn482	0.30 ms					Polarity Detection Speed Loop Integral Time Constant	Immediately
Pn483	30%					Forward Force Limit	Immediately
Pn484	30%					Reverse Force Limit	Immediately
Pn485	20 mm/s					Polarity Detection Reference Speed	Immediately
Pn486	25 ms					Polarity Detection Reference Accel/Decel Time	Immediately
Pn487	0 ms					Polarity Detection Constant Speed Time	Immediately
Pn488	100 ms					Polarity Detection Reference Waiting Time	Immediately
Pn48E	10 mm					Polarity Detection Range	Immediately
Pn490	100%					Polarity Detection Load Level	Immediately



Parameter	Factory Setting					Name	When Enabled
Pn495	100%					Polarity Detection Confirmation Force Reference	Immediately
Pn498	10 deg.					Polarity Detection Allowable Error Range	Immediately
Pn501	10					Reserved Parameter	–
Pn506	0 ms					Brake Reference - Servo OFF Delay Time	Immediately
Pn508	50 ms					Waiting Time for Brake Signal When Motor Running	Immediately
Pn509	20 ms					Instantaneous Power Cut Hold time	Immediately
Pn50A	1881					Input Signal Selection 1	After restart
Pn50B	8822					Input Signal Selection 2	After restart
Pn50C	8888					Reserved Parameter	–
Pn50D	8888					Reserved Parameter	–
Pn50E	0000					Output Signal Selection 1	After restart
Pn50F	0100					Output Signal Selection 2	After restart
Pn510	0000					Output Signal Selection 3	After restart
Pn511	6543					Input Signal Selection 5	After restart
Pn512	0000					Output Signal Inverse Setting	After restart
Pn513	0000					Reserved Parameter	–
Pn517	0000					Reserved Parameter	–
Pn51E	100%					Excessive Position Error Warning Level	Immediately
Pn520	5242880 reference unit					Excessive Position Error Alarm Level	Immediately
Pn522	7 reference unit					Positioning Completed Width	Immediately
Pn524	1073741824 reference unit					NEAR Signal Width	Immediately
Pn526	5242880 reference unit					Excessive Position Error Alarm Level at Servo ON	Immediately
Pn528	100%					Excessive Position Error Warning Level at Servo ON	Immediately
Pn52B	20%					Overload Warning Level	Immediately
Pn52C	100%					Derating of Base Current at Detecting Overload of Motor	After restart
Pn52F	0FFF					Monitor Display at Power ON	Immediately
Pn530	0000					Program JOG Operation Related Switch	Immediately
Pn531	32768 reference unit					Program JOG Movement Distance	Immediately
Pn534	100 ms					Program JOG Acceleration/Deceleration Time	Immediately
Pn535	100 ms					Program JOG Waiting Time	Immediately
Pn536	1 time					Number of Times of Program JOG Movement	Immediately
Pn550	0.0 V					Analog Monitor 1 Offset Voltage	Immediately
Pn551	0.0 V					Analog Monitor 2 Offset Voltage	Immediately
Pn552	×1					Analog Monitor Magnification (×1)	Immediately
Pn553	×1					Analog Monitor Magnification (×2)	Immediately
Pn560	40.0%					Remained Vibration Detection Width	Immediately

Parameter	Factory Setting						Name	When Enabled
<b>Pn561</b>	100%						Overshoot Detection Level	Immediately
<b>Pn580</b>	10						Reserved Parameter	Immediately
<b>Pn581</b>	20 mm/s						Zero Speed Level	Immediately
<b>Pn582</b>	10 mm/s						Speed Coincidence Signal Output Width	Immediately
<b>Pn583</b>	10 mm/s						Brake Reference Output Speed Level	Immediately
<b>Pn584</b>	10000 mm/s						Speed Limit Level at Servo ON	Immediately
<b>Pn585</b>	50 mm/s						Program JOG Movement Speed	Immediately
<b>Pn586</b>	0%/maxvel						Motor Running Air-cooling Ratio	Immediately
<b>Pn587</b>	0000						Polarity Detection for Absolute Scale Selection	Immediately
<b>Pn600</b>	0 W						Regenerative Resistor Capacity	Immediately
<b>Pn601</b>	0						Reserved Parameter	–
<b>Pn800 to Pn95F</b>	0						Reserved Parameter	–

# Index

## Symbols

*BB	4-29
*HBB	4-29
*N-OT	4-29
*P DET	4-29
*P-OT	4-29
*PT NT	4-29
*RUN	4-29
/ALM-RST	4-39
/BK	3-23, 4-16
/BK-	3-18
/CLT	3-23, 4-32
/COIN	3-23
/HWBB1	3-19
/HWBB2	3-19
/N-CL	4-31
/NEAR	3-23
/P-CL	4-31
/SI0	3-18
/SI3	3-18
/SI4	3-18
/SI5	3-18
/SI6	3-18
/SO1-	3-18
/SO1+	3-18
/SO2+	3-18
/SO2-	3-18
/SO3-	3-18
/SO3+	3-18
/S-RDY	3-23, 4-40
/TGON	3-23, 4-40
/V-CMP	3-23
/VLT	3-23
/WARN	3-23, 4-39

## Numerics

600 V grade heat-resistant polyvinyl chloride insulated wire	3-3
--	-----

## A

absolute linear scale reception sequence	4-36
AC reactor	3-40
AC/DC reactor for harmonic suppression	3-40
adjustment	
safety precautions on adjustment of servo gains	5-8
tuning-less function	5-10
tuning-less level	5-11
adjustments	
additional adjustment function	5-52
compatible adjustment function	5-60
advanced autotuning (Fn201)	5-16
anti-resonance control adjustment function	5-22
calculating mass	5-19
feedforward	5-23
friction compensation	5-23
mode selection	5-19
notch filter	5-22
STROKE	5-19
type selection	5-19
vibration suppression	5-22

advanced autotuning by reference (Fn202)	5-25
anti-resonance control adjustment function	5-29
feedforward	5-30
friction compensation	5-30
mode selection	5-27
notch filter	5-29
type selection	5-27
vibration suppression	5-29
alarm	
alarm history display (Fn000)	6-3
clearing alarm history (Fn006)	6-15
list of alarms	8-2
reset methods	4-39
stopping method for linear servomotor after servo OFF	
command is received	4-19
alarm reset capability	8-2
alarm stopping method	8-2
ALM	4-39
ALM-	3-18
ALM+	3-18
analog monitor	
connector CN5 for analog monitor	5-7
gain adjustment of analog monitor output (Fn00D)	6-18
monitor factor	5-6
monitoring analog signals	5-5
offset adjustment of analog monitor output (Fn00C)	6-16
anti-resonance control adjustment function (Fn204)	5-41
applicable standards	1-5
automatic gain switching	5-52
automatic offset-signal adjustment of the motor current detection (Fn00E)	6-20
automatically setting the notch filter	5-11

## B

BB	iii
brake signal	4-16

## C

CE	xv
changing detection timing of overload alarm (A.720)	4-26
changing detection timing of overload warning (A.910)	4-25
CN2	3-29
CN3	1-2
CN7	1-2
CN8	3-19
coast to a stop	4-7
communications LED indicator (COM)	1-2
connection example of a linear scale	
absolute linear scale made by Magnescale Co., Ltd.	3-31
absolute linear scale made by mitutoyo	3-30
linear scale made by heidenhain	3-29
linear scale made by renishaw	3-30
connection example of EDM1 output signal	4-47
connection example of input signals (HWBB signals)	4-44
correct grounding	3-37
current control mode selection	5-59
current gain level setting	5-59

## D

damping gain	5-41
DC power input	
parameter settings	3-15
DC power supply input	
wiring examples	3-16
DC reactor	3-40

DC reactor connection terminal for power supply harmonic suppression ----- 3-2  
 digital operator display during testing without motor ----- 4-29  
 DIP switch (S2) ----- 1-2

**E**

easyFFT (Fn206) ----- 6-31  
 EDM1 ----- 3-27, 4-46  
 electronic gear ----- 4-9  
 electronic gear ratio ----- 4-10  
 encoder output pulse ----- 4-12  
 encoder output pulse setting ----- 4-14  
 encoder output resolution ----- 4-14  
 error detection in HWBB signal ----- 4-43  
 european standards ----- xv  
 examples of SERVOPACK I/O signal connection to the host controller  
   sequence input circuits ----- 3-24  
   sequence output circuits ----- 3-26  
 external device monitor ----- 4-46  
 external force limit ----- 4-31  
 external inrush current limit circuit ----- 3-15  
 external regenerative resistor ----- 3-33  
 external regenerative resistor terminals ----- 3-2

**F**

feedforward control compensation ----- 5-60  
 feedforward reference ----- 5-60  
 FG ----- 3-18, 3-20  
 force control tolerance ----- 1-5  
 force reference filter ----- 5-65  
 forward ----- 4-5  
 forward external force limit ----- 4-31  
 friction compensation ----- 5-57

**G**

Gr.1 ----- 8-2  
 Gr.1 alarm ----- 4-20  
 Gr.2 ----- 8-2  
 Gr.2 alarm ----- 4-20  
 ground fault detector ----- 3-11

**H**

hard wire base block (HWBB) function ----- 4-41  
 hard wire base block (HWBB) state ----- 4-42  
 holding brakes ----- 4-15

**I**

I/O signal (CN1)  
   I/O signal allocations ----- 3-21  
   names and functions ----- 3-18  
   output signal allocation ----- 3-23  
   output signals ----- 3-18  
 infinite time operation ----- 6-9  
 input signal (HWBB signal) specifications ----- 4-44  
 input signals ----- 4-31  
 instantaneous power interruption settings ----- 4-21  
 internal block diagrams ----- 1-8  
 internal force limit ----- 4-30  
 interpreting the input signal allocation tables ----- 3-21  
 interpreting the output signal allocation tables ----- 3-23

**J**

JOG operation (Fn002) ----- 6-4

**L**

limit switch ----- 4-6  
 limiting force ----- 4-30  
 line driver output circuit ----- 3-26  
 linear scale  
   linear scale signal (CN2) names and functions ----- 3-29  
 linear scale counting down ----- 4-5  
 linear scale counting up ----- 4-5  
 linear servomotor movement direction ----- 4-5

**M**

machine vibration ----- 6-36  
 main circuit  
   names and specifications ----- 3-2  
   wires ----- 3-3  
   wiring examples ----- 3-5  
 main circuit minus terminal ----- 3-3  
 main circuit plus terminal ----- 3-3  
 manual gain switching ----- 5-52  
 manual offset-signal adjustment of the motor current detection (Fn00F) ----- 6-21  
 molded-case circuit breaker ----- 3-11  
 monitor mode  
   monitor mode (Un□□□) ----- 2-7  
 monitor modes  
   list of monitor modes ----- 7-2, 9-23  
   monitor displays ----- 7-3  
 movement detection output signal ----- 4-40

**N**

noise control and measures for harmonic suppression ----- 3-36  
   noise filter ----- 3-37  
   precautions on connecting noise filter ----- 3-38  
 north american safety standards ----- xv  
 N-OT ----- 3-18, 4-6  
 notch filters ----- 5-65

**O**

one-parameter tuning  
   example ----- 5-39  
 one-parameter tuning (Fn203) ----- 5-32  
 anti-resonance control adjustment function ----- 5-37  
 feedforward ----- 5-38  
 friction compensation ----- 5-38  
 notch filter ----- 5-37  
 tuning mode selection ----- 5-33, 5-35  
 type selection ----- 5-33, 5-35  
 online vibration monitor (Fn207) ----- 6-36  
 operation  
   inspection and checking before operation ----- 4-4  
   operating the linear servomotor alone ----- 4-4  
 origin search (Fn003) ----- 6-6  
 origin setting (Fn020) ----- 4-34  
 output phase ----- 4-12  
 overtravel (OT) ----- 4-6

**P**

P Control ----- 5-60  
 panel display ----- 2-2  
 PAO serial data ----- 4-38

parameters	
classifications	2-4
initializing parameter settings (Fn005)	6-14
list of parameters	9-3
notation (numeric parameters)	2-4
notation (selection parameters)	2-4
parameter recording table	9-24
setting method for numeric parameters	2-5
setting method for selection parameters	2-6
setting parameters (Pn□□□)	2-5
tuning parameters	2-4
write prohibited setting (Fn010)	6-22
photocoupler output circuit	3-26
PI Control	5-60
polarity detection (Fn080)	4-35
P-OT	3-18, 4-6
power LED indicator (POWER)	1-2
power ON sequence	3-5
precautions for wiring	3-11
program JOG operation (Fn004)	6-8
program JOG operation patterns	6-9
protection class/pollution degree	1-5
<b>R</b>	
reference unit	4-9
regenerative resistor unit	3-34
resetting configuration error of option module (Fn014)	6-26
resetting the HWBB state	4-43
resonance frequency	6-31
reverse	4-5
reverse external force limit	4-31
risk assessment	4-41
rotary switch (S1)	1-2
<b>S</b>	
S1 switch	4-3
S2 switch	4-3
safety	4-50
safety function	4-41
application example	4-48
confirming safety functions	4-49
example of I/O signal connections	3-20
precautions	4-51
safety function signal (CN8) names and functions	3-19
safety output circuit	3-27
SEMI-F47 function	4-22
serial converter unit	3-31
servo alarm output signal	4-39
servo gain	5-3
servo ready output signal	4-40
servomotor model display (Fn011)	6-24
SERVOPACKs	1-2
ambient/storage humidity	1-5
basic specifications	1-5
display of SERVOPACK and servomotor ID (Fn01E)	6-29
examples of servo system configurations	
(SGDV-□□□AE5A)	1-16
examples of servo system configurations	
(SGDV-□□□DE5A)	1-18
examples of servo system configurations	
(SGDV-□□□FE5A)	1-15
inspection and maintenance	1-20
model designation	1-19
part names	1-2
ratings	1-3
software version display (Fn012)	6-25
surrounding air/storage temperature	1-5
using more than one SERVOPACK	3-17
setting absolute linear scale	4-33
setting motor overload detection level	4-25
setting regenerative resistor capacity	3-35
single-phase 100-V	
wire types	3-3
single-phase 200-V power supply input	
molded-case circuit breaker	3-14
parameter setting	3-12
power supply capacities and power losses	3-14
SERVOPACK main circuit wire	3-13
wiring example	3-13
software reset (Fn030)	6-30
specifications of EDM1 output signal	4-47
specifications of serial converter unit	3-31
speed control range	1-5
speed detection method selection	5-59
speed regulation	1-5
standard power supply input	
molded-case circuit breaker	3-10
power supply capacities and power losses	3-9
SERVOPACK main circuit wires	3-4
wire types	3-3
wiring examples	3-5
status display	2-2
stop by dynamic brake	4-7
stopping linear servomotor after receiving servo OFF	
command	4-19
stopping method for linear servomotor for Gr.1 alarms	4-20
stopping method for linear servomotor for Gr.2 alarms	4-20
switching condition A	5-53
switching gain settings	5-52
<b>T</b>	
test without motor function	4-27
time stamps	6-3
troubleshooting malfunction based on operation and conditions	
of the linear servomotor	8-29
tuning parameters	2-4
tuning-less adjustment level	5-11
tuning-less load level	5-12
<b>U</b>	
UL standards	xv
using the mode switch (P/PI switching)	5-60
using the SERVOPACK with single-phase power supply	
input	3-12
utility functions	9-2
utility functions that can be write-protected	6-22
<b>V</b>	
vibration detection level initialization (Fn01B)	6-27
vibration suppression function	
feedforward	5-50
vibration suppression function (Fn205)	5-41
vibration/shock resistance	1-5
<b>W</b>	
warning	
list of warnings	8-23
troubleshooting of warnings	8-25
warning output signal	4-39
when using the linear servomotor on a vertical axis	4-6

## Revision History

The revision dates and numbers of the revised manuals are given on the bottom of the back cover.

MANUAL NO. SIEP S800000 66A

Published in Japan November 2009 09-11 ◇-1

Date of publication  
 Date of original publication  
 Revision number  
 WEB revision number

Date of Publication	Rev. No.	WEB Rev. No.	Section	Revised Content
November 2010	◇	1	Front cover	Revision: Format
			3.4.1 (2), 3.4.2 (3), 4.7.1, 4.7.1 (5), 4.7.2 (1), 4.7.3 (1)	Revision: Connection example
			3.6.2 (4), 4.2.4 (1), 4.5.1, Index	Revision: Company name Sony Manufacturing Systems → Magnescale Co., Ltd.
			4.2.6, 9.1.2	Revision: Setting units of Pn281
			5.3.1(1), 5.4.1(1)	Revision: Description of things to do before advanced autotuning and advanced autotuning by reference
			5.8.1 (4), (5)	Revision: Applicable control method
			5.8.4	Revision: Description of current gain level setting
			8.1.2	Revision: Note of A.042
			9.1.2	Revision: Description of the second digit (Speed Limit Selection) of Pn408
			9.1.2, 9.3	Addition: Pn517 (Reserved Parameter)
		Back cover	Revision: Address, format Addition: Original instructions	
November 2009	-	0	-	First edition

# AC Servo Drives

# $\Sigma$ -V Series

## USER'S MANUAL

## Design and Maintenance

### Linear Motor

### Command Option Attachable Type

---

**IRUMA BUSINESS CENTER (SOLUTION CENTER)**

480, Kamifujisawa, Iruma, Saitama 358-8555, Japan  
Phone 81-4-2962-5151 Fax 81-4-2962-6138

**YASKAWA AMERICA, INC.**

2121 Norman Drive South, Waukegan, IL 60085, U.S.A.  
Phone (800) YASKAWA (800-927-5292) or 1-847-887-7000 Fax 1-847-887-7310

**YASKAWA ELÉTRICO DO BRASIL LTDA.**

Avenida Fagundes Filho, 620 São Paulo-SP CEP 04304-000, Brazil  
Phone 55-11-3585-1100 Fax 55-11-5581-8795

**YASKAWA EUROPE GmbH**

Hauptstraße 185, Eschborn 65760, Germany  
Phone 49-6196-569-300 Fax 49-6196-569-398

**YASKAWA ELECTRIC UK LTD.**

1 Hunt Hill Orchardton Woods Cumbernauld, G68 9LF, United Kingdom  
Phone 44-1236-735000 Fax 44-1236-458182

**YASKAWA ELECTRIC KOREA CORPORATION**

7F, Doore Bldg. 24, Yeoido-dong, Yeoungdungpo-gu, Seoul 150-877, Korea  
Phone 82-2-784-7844 Fax 82-2-784-8495

**YASKAWA ELECTRIC (SINGAPORE) PTE. LTD.**

151 Lorong Chuan, #04-01, New Tech Park 556741, Singapore  
Phone 65-6282-3003 Fax 65-6289-3003

**YASKAWA ELECTRIC (SHANGHAI) CO., LTD.**

No.18 Xizang Zhong Road. 17F, Harbour Ring Plaza Shanghai 200001, China  
Phone 86-21-5385-2200 Fax 86-21-5385-3299

**YASKAWA ELECTRIC (SHANGHAI) CO., LTD. BEIJING OFFICE**

Room 1011, Tower W3 Oriental Plaza, No.1 East Chang An Ave.,  
Dong Cheng District, Beijing 100738, China  
Phone 86-10-8518-4086 Fax 86-10-8518-4082

**YASKAWA ELECTRIC TAIWAN CORPORATION**

9F, 16, Nanking E. Rd., Sec. 3, Taipei 104, Taiwan  
Phone 886-2-2502-5003 Fax 886-2-2505-1280



YASKAWA ELECTRIC CORPORATION

In the event that the end user of this product is to be the military and said product is to be employed in any weapons systems or the manufacture thereof, the export will fall under the relevant regulations as stipulated in the Foreign Exchange and Foreign Trade Regulations. Therefore, be sure to follow all procedures and submit all relevant documentation according to any and all rules, regulations and laws that may apply.

Specifications are subject to change without notice for ongoing product modifications and improvements.

© 2009-2010 YASKAWA ELECTRIC CORPORATION. All rights reserved.

MANUAL NO. SIEP S800000 66A

Published in Japan November 2010 09-11 -1

10-10-4

Original instructions