

# MP2600iec Webinar SGDV-OCC02A

Motion & Control  
Technical Department



## Contents

1. Product MP2600iec
  2. Hardware MP2600iec
  3. Engineering Tool MotionWorks IEC
  4. Applications with MP2600iec
  5. MP2600iec Documentation
  6. Accessories, Part numbers
  7. Installation
  8. Summary
- Appendix: YEU\_MP2600iec\_Launch\_Package



Modbus/TCP



$\Sigma$ -V

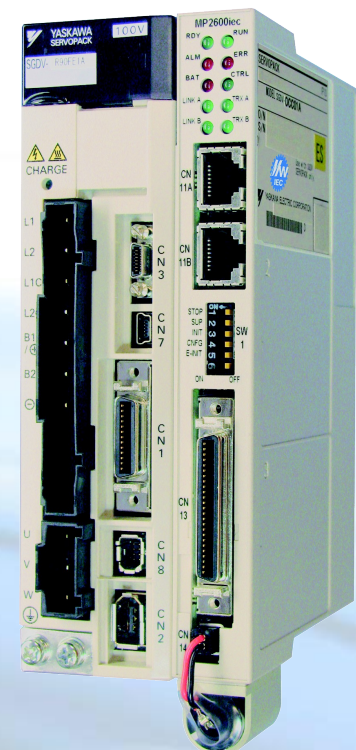

Drives + Motion Division

# 1. Product MP2600iec

MP2600iec is a machine controller fully integrated into Sigma-5.

- IEC61131-3 on the Sigma-5 servo amplifier provides standardized programming on Yaskawa's high-quality servo system
- One software platform, MotionWorks IEC, allows applications to scale up from single to multi-axis control.

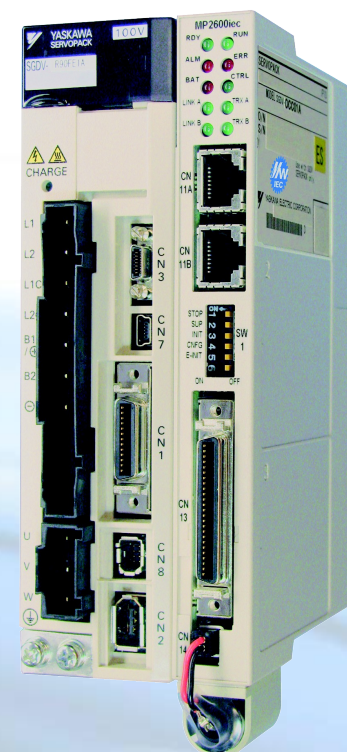

Modbus/TCP

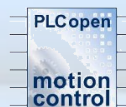

# 1. Product MP2600iec

MP2600iec is a machine controller fully integrated into Sigma-5.

- PLCopen Function Blocks in MotionWorks IEC simplify programming
- Diagnostic Web server reduces field maintenance time
- Optional OPC server allows for HMI or Data Acquisition
- Sigma-5 autotuning and vibration suppression algorithms provide easy setup
- Wide product range of Sigma-5 enables flexible designs
  - 230/400 VAC from 50W to 15kW
  - Wide range of rotary and linear motors
  - Intergrated Safety (STO)

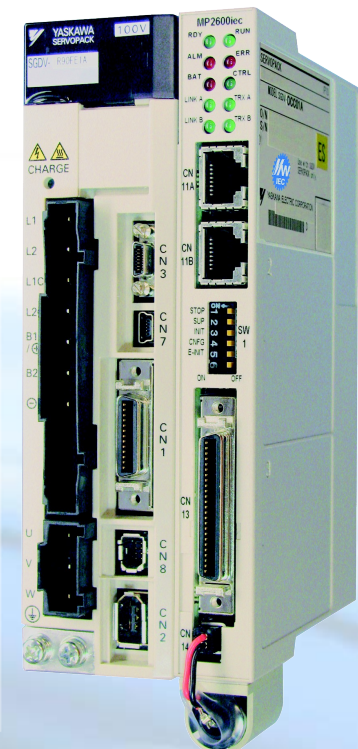

Modbus/TCP



$\Sigma$ -V

Drives + Motion Division

# 1. Product MP2600iec

Programmable Motion with Unmatched Scalability and Modularity

- MP2310iec, up to 16 Axis and 3 I/O slots
- MP2300Siec, up to 16 Axis and 1 I/O slot
- MP2600iec, for 1.5 Axis

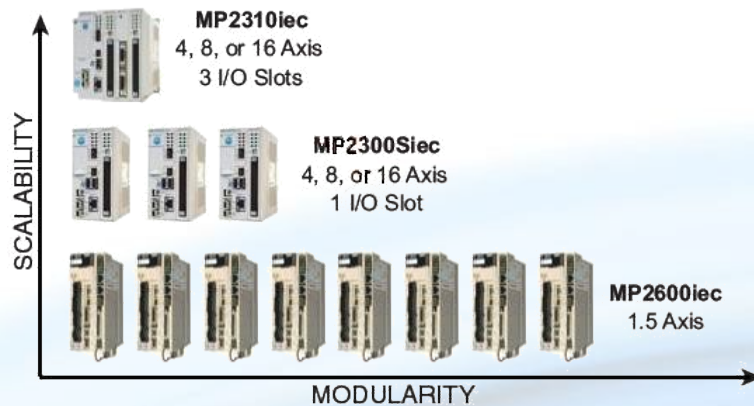

Modbus/TCP



$\Sigma$ -V

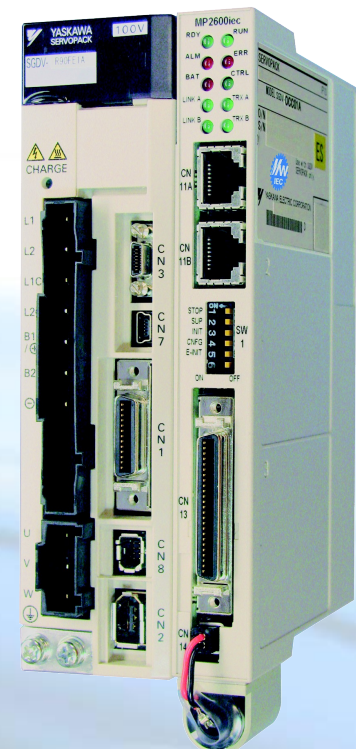

Drives + Motion Division

# 1. Product MP2600iec

## Programmable Motion

- Point to Point
- Electronic Gearing
- Blended Moves
- E-CAM

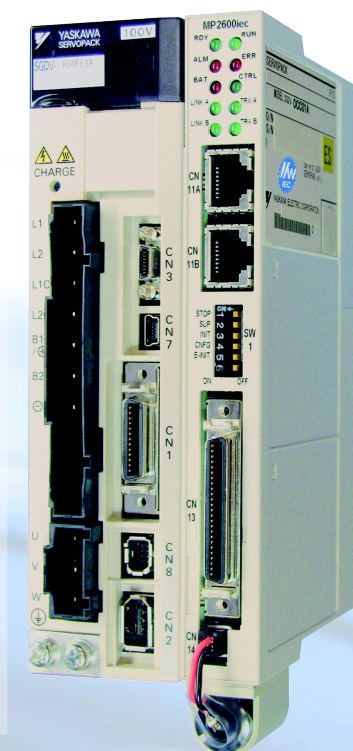
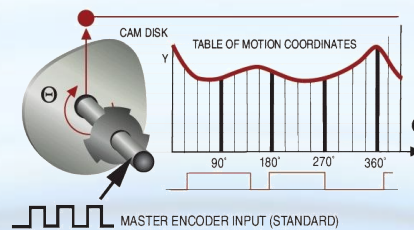
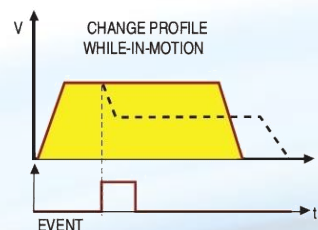
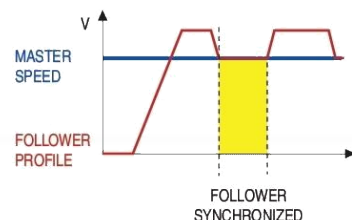
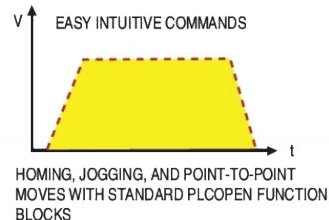

Modbus/TCP

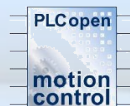

## 2. Hardware MP2600iec

### MP2600iec Specifications

- CPU 200MHz, 32 bit, ARM9
- Memory
  - SDRAM 32MB
  - SRAM 512kB with battery backup
  - Flash 4 MB flash. Code and parameter storage
- Operator interface
  - 10 LEDs red and green  
(Operating mode, communication and error status)
  - 6 x DIP switch for User configuration  
(Operating mode and communication configuration)



Modbus/TCP

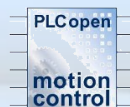

$\Sigma$ -V

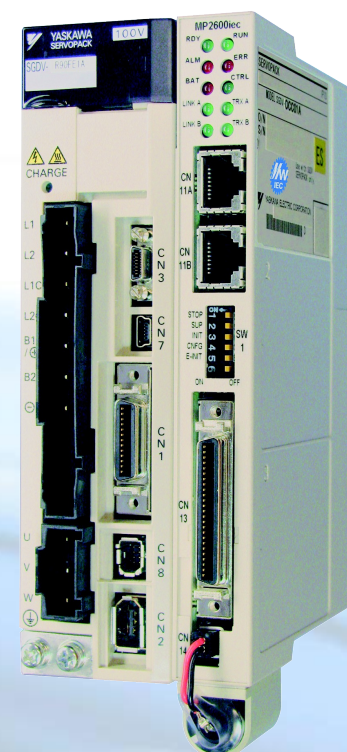

Drives + Motion Division

## 2. Hardware MP2600iec

### MP2600iec Specifications

- Network 2 ports 100base TX Ethernet
- User I/O
  - Controller (CN13)
    - Digital input 8 programmable inputs
    - Digital output 8 programmable outputs
    - Analogue input 1 ch +/- 10V, 16 bit
    - Analogue output 1 ch +/- 10V, 16 bit
    - Pulse counter RS-422 pulse counter (quadrature, pulse and direction, up/down counter modes) with 5, 12 and 24V position latch inputs



Modbus/TCP

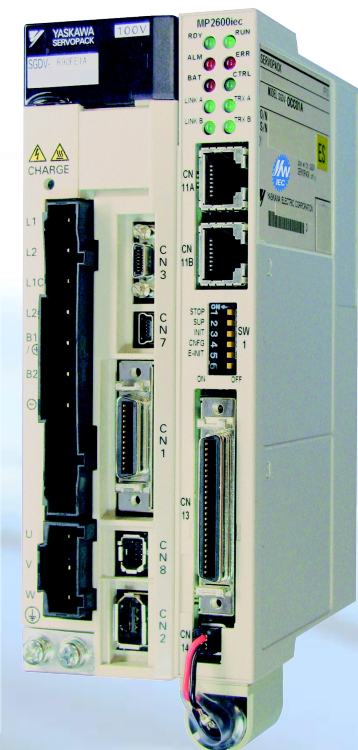

Drives + Motion Division



## 2. Hardware MP2600iec

### MP2600iec Specifications

- User I/O
  - Servo (CN1)
    - 7 digital inputs  
Functions: Forward run or reverse run prohibited, forward, latch inputs or reverse torque limit
    - 3 digital outputs  
Position completion, speed coincidence, motor rotation, servo ready, torque limit detection, speed limit detection, brake, warning, near

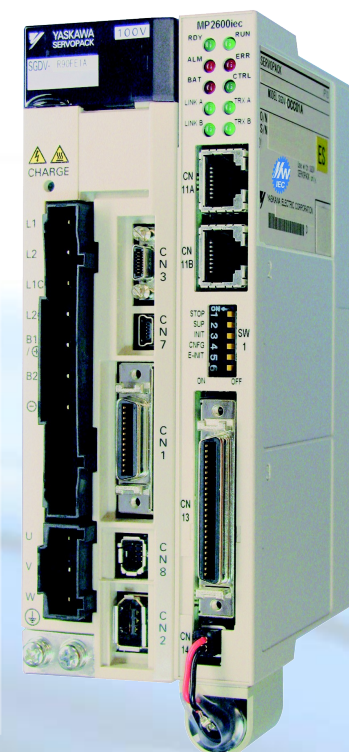

Modbus/TCP



## 2. Hardware MP2600iec

### MP2600iec Specifications

- Network capability
  - OPC (Client and Server required)
  - EtherNet/IP
  - Modbus TCP
- Programming standards IEC61131-3/PLCopen
- Diagnostic/configuration interface Web interface
- Motion control performance
  - 1 controlled axis
  - 1 external position input at a trajectory update rate of 1kHz
- Servo-Side Safety Functions (STO)



Modbus/TCP

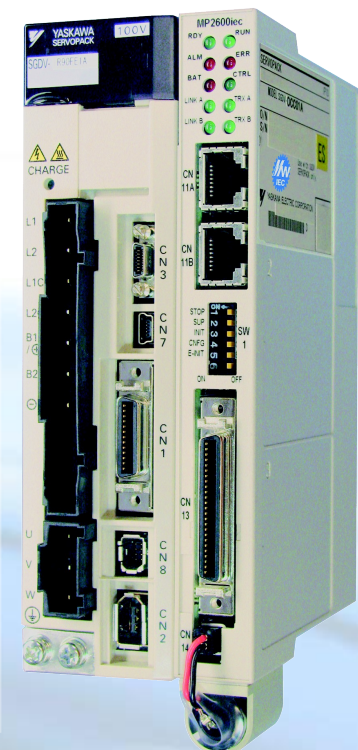

Drives + Motion Division

## 2. Hardware MP2600iec

### MP2600iec appearance

- LED (10 points)
- Ethernet Port A
- Ethernet Port B
- DIP Switch (6 points)
- I/O Port (CN13)
  - Digital I/O
  - Analog I/O
  - External Encoder
- Lithium Battery, 3.6V
  - preserve retained variables
  - Absolute encoder offset
  - Real-time clock data

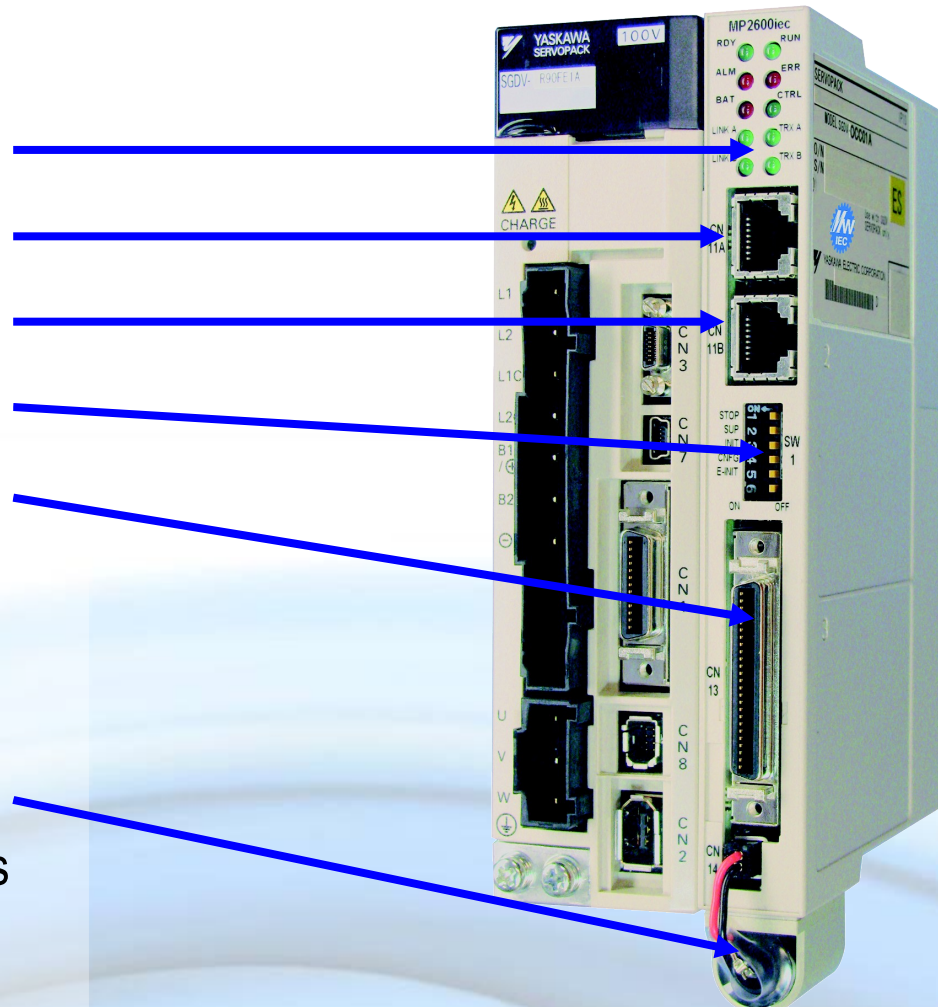

### DIP Switches on MP2600iec

#### ■ Setting

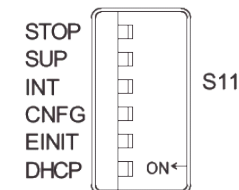

Switch	Name	Setting	Operating Mode	Setting for Normal Operation	Details
1	STOP	ON	User program execution inhibited	OFF	Inhibits user program execution
		OFF	Normal operation		
2	SUP	ON	Firmware programming mode	OFF	Enables controller firmware programming. (See Section 11)
		OFF	Normal operation		
3	INIT	ON	SRAM/clock initialization and configuration bypass mode	OFF	Set to ON to bypass the stored configuration (e.g. in case of a configuration problem that prevents controller startup) or to initialize the SRAM contents and clock settings after backup power has been lost (See Section 7.1).
		OFF	Normal operation		
4	CNFG	ON	Normal operation	ON	Always set to ON
		OFF	Do not set (reserved for future use)		
5	E-INIT	ON	Force Ethernet address setting for Port A to 192.168.1.1 and Port B to 192.168.2.1	OFF	Enables use of the default Ethernet addresses
		OFF	Normal Operation		
6	DHCP	ON	DHCP-configured IP settings	OFF	Enables use of DHCP for IP setting configuration
		OFF	Manually-configured IP settings		

### 3. Engineering Tool MotionWorksIEC

There are two versions available.

- MotionWorksIEC Express
- MotionWorksIEC Professional
  
- Upgrade on Software Download Portal
  - <http://www.yaskawa.eu.com/index.php?id=899>



	<i>MotionWorks</i> IEC EXPRESS	<i>MotionWorks</i> IEC PROFESSIONAL
Tasks	1	16
IEC61131-3 Languages	Ladder Diagram Function Blocks Structured Text	Ladder Diagram Function Blocks Structured Text Sequential Function Chart Instruction List

# 3. Engineering Tool MotionWorksIEC

## MotionWorksIEC Express

- Programming Languages
  - Ladder Diagram
  - Function Block Diagram
  - Structured Text
- Tasks
  - Motion task
  - One task for plc program

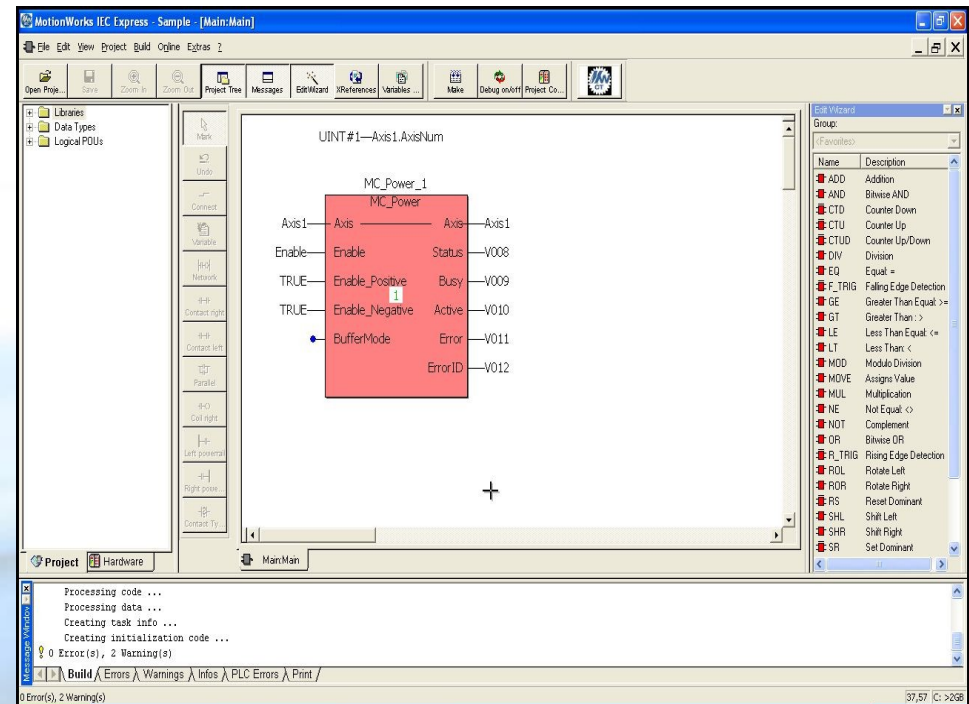

# 3. Engineering Tool MotionWorksIEC

## MotionWorksIEC Pro

- Programming Languages
  - Ladder Diagram
  - Function Block Diagram
  - Instruction List
  - Structured Text
  - Sequential Function Chart
- Tasks
  - Motion task
  - 16 tasks for plc program
    - Fastest task = motion task

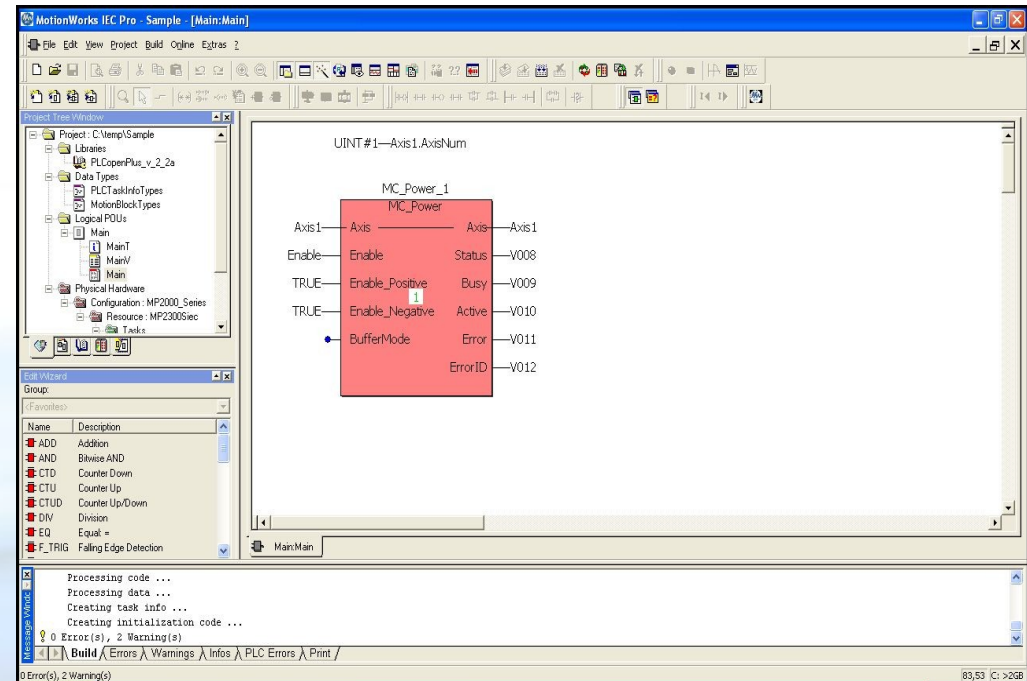



#### Firmware upgrade

- It is possible to upgrade the Controller firmware in the field.
- For detailed instructions, please refer to Product Note [PN.MCD.0.03.083](#)



## Applications

- Random Rotary Placer (CAM)
- Rotary Table (Indexer)
- Screw Feeder (Feeder)
- Precision Grinder (Electronic Gearing)



## Application Documents

- PLC Open Function Blocks
- FeedToLength\_FB\_Manual\_v002.pdf
- Electronic Camming E-Stop Recovery Example Code Manual.pdf

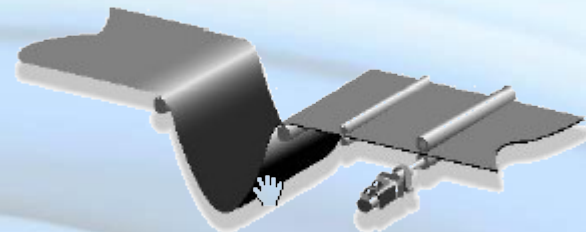
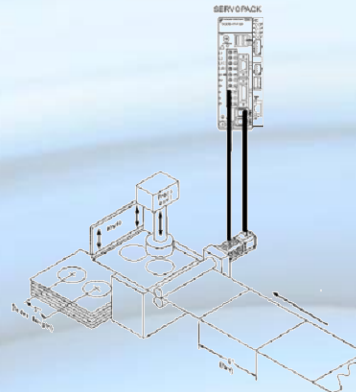
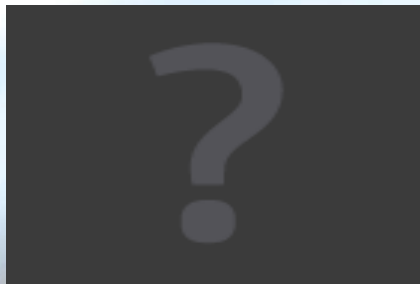

## Documentation

- Catalogue:
  - Sigma-5\_big: [YEU\\_KAEPS80000042F\\_6\\_1](#)
  - Sigma-5\_small: [YEU MuC Sigma5 Intro EN v1 0211.pdf](#)
  - MP2600iec: [YAS Flyer MP2600iec 20110428.pdf](#)
- Manual:
  - MP2600iec: [YEA-SIA-IEC-6\\_MP2600iec\\_HW\\_Manual.pdf](#)
  - Amplifier Rotary: [SIEPS80000060a\\_0\\_1.pdf](#)
  - Amplifier Linear: [SIEPS80000066a\\_0\\_0.pdf](#)
- Technical Notes:
  - Firmware upgrade: [PN.MCD.08.083\\_UpgradingMP2000iec\\_.pdf](#)
  - MP2600iec start-up: [YEGT1006MP26-01.pdf](#)
- Installation
  - Installation Guide: [YAI-SIA-IEC-7\(Installation Guide\).pdf](#)
  - Safety Precaution: [TOBP C720829 00A\(SAFETY PRECAUTIONS\).pdf](#)

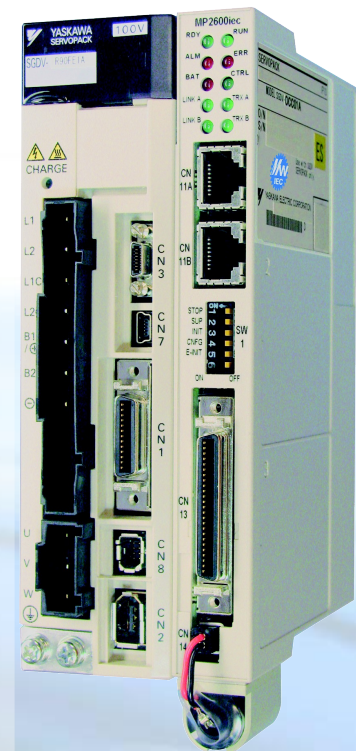

## 6. Accessories, Part number

System Components			
Type	Model	Part Number	Note
Accessories/Cables	Battery	JZSP-BA01	Replacement
	Battery Holder Kit	SGDV-OZC02A	Replacement (does not include battery)
	CN13 (MP2600iec) Terminal Block Conversion Kit	CBK-U-MP2Bxx	xx denotes cable length (m) A5 = 0.5 01 = 1 03 = 3
	CN13 (MP2600iec) (Flying Leads)	CFC-U-MP2Bxx	
	CN1 (Servo Amp) Terminal Block Conversion Kit	SBK-U-MP2Bxx	
	CN1 (Servo Amp) Cable (Flying Leads)	JZSP-CSI02-x-E	x denotes cable length (m) A = 1 B = 2 C = 3
Communication	Ethernet Cable	N/A	Use commonly available shielded Ethernet cable
Software	MotionWorks IEC Express	PDE-U-IECSx	x denotes number of software licenses A = 1 B = 5 C = 10
	MotionWorks IEC Pro	PDE-U-IECPx	
	OPC Server	PDE-U-OPCPx	x denotes number of software licenses A = 1 B = 5 C = 10 D = 20

## 6. Accessories, Part number

### Battery installation on MP2600iec

- A 3.6V lithium battery must be used to retain SRAM data in the controller when the power is off.
- SRAM will last for one hour without the battery connected.
- The battery power can be applied through the battery connector (CN14), or through the I/O connector (CN13 pins 7 [+] & 32 [-]).
- The battery is necessary for preserving retained variables, absolute encoder offset, and real-time clock data.

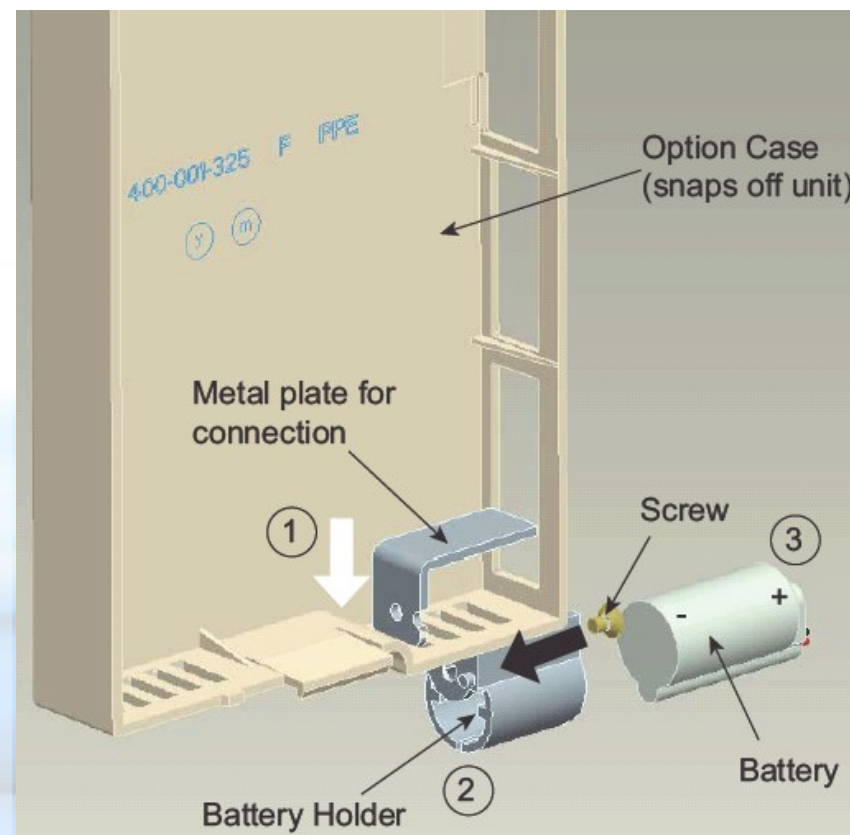

## 6. Accessories, Part number

### Battery Holder installation instruction:

1. Remove the plastic from the controller by pressing the tabs at the top and bottom.
2. Insert the tab of the metal plate into the last vent slot on the bottom front of the case as shown.
3. Line up the hole in battery holder with the hole in the metal plate and secure the battery holder with the screw provided.
4. Attach the extension cable to the battery and place the battery into the battery holder with the cable facing forward.
5. Attach the plastic case to the controller.
6. Plug the battery extension cable into the battery connector (CN14).

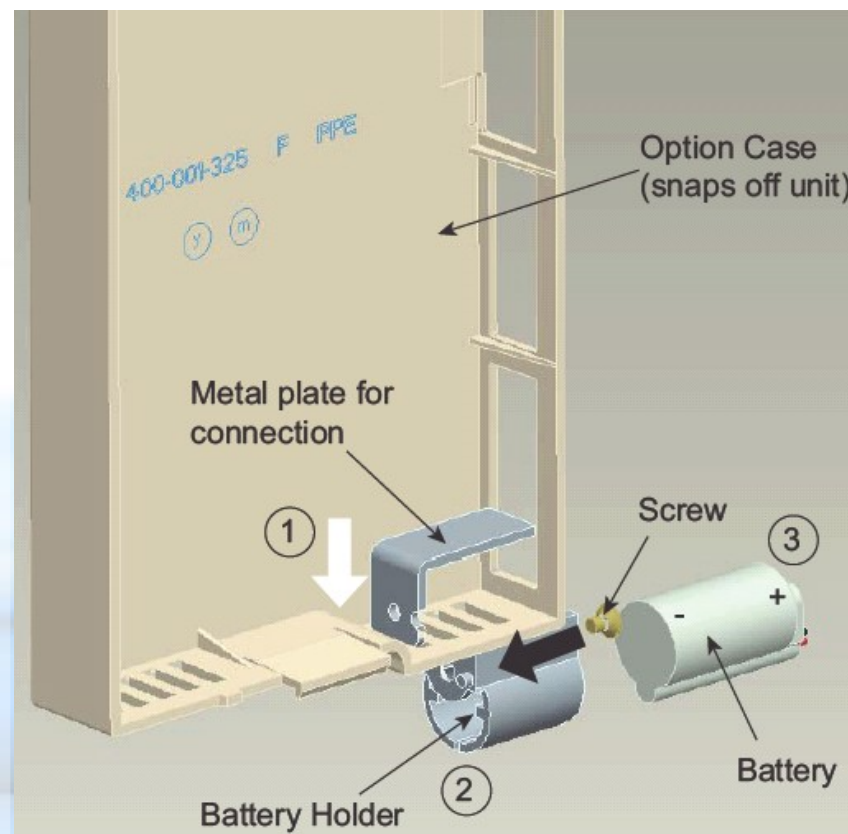

# 6. Accessories: Terminal Block

## Terminal Block for MP2600iec

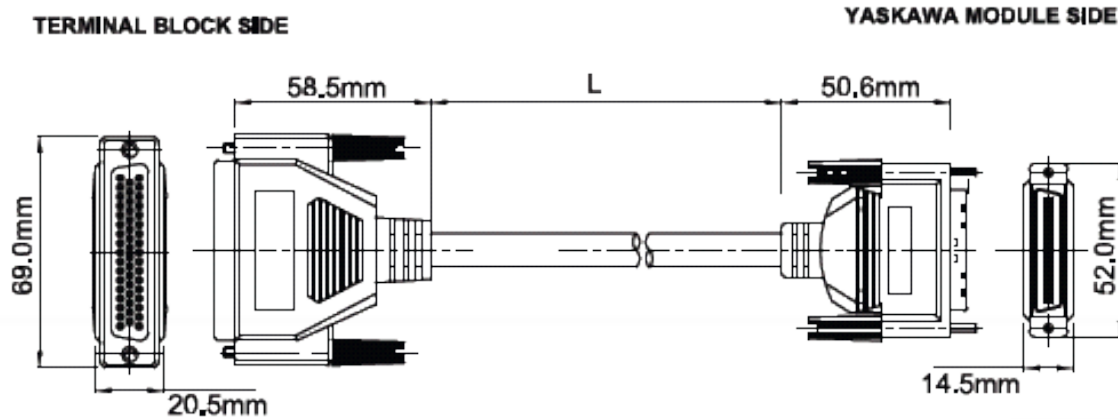

CABLE SPECIFICATION (mm)	
OUTER DIAMETER	8.5 +/- 0.1mm
BENDING RADIUS	6 x O.D. MINIMUM 15 x O.D. FOR LONG TERM RELIABILITY

ITEM#	L = LENGTH (mm)
CBK-U-MP2B-A5	500 +/- 38.1
CBK-U-MP2B-01	1000 +/- 38.1
CBK-U-MP2B-03	3000 +/- 38.1

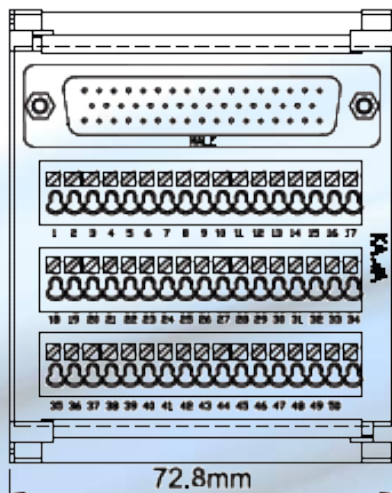

SIDE VIEW WITH CABLE ATTACHED

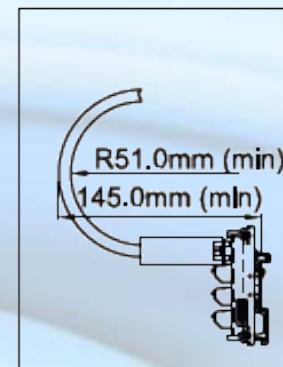

# 6. Accessories: Terminal Block

## Terminal Block for MP2600iec

- Layout

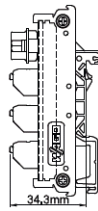
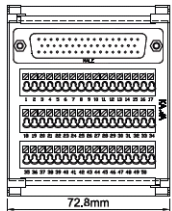

Pin No.	Signal Name	I/O	Function	Pin No.	Signal Name	I/O	Function
1	AO	O	Analog output	26	AO_GND	O	Analog output ground
2	AI	I	Analog input	27	AI_GND	I	Analog input ground
3	-	-	-	28	reserved	-	-
4	PA+	I	Phase A pulse (+)	29	PB+	I	Phase B pulse (+)
5	PA-	I	Phase A pulse (-)	30	PB-	I	Phase B pulse (-)
6	GND	P	Encoder input ground	31	GND	P	Encoder input ground
7	BAT+	P	Controller SRAM Battery (+)	32	BAT-	P	Controller SRAM Battery (-)
8	-	-	-	33	-	-	-
9	PILC5V	I	Phase-C latch pulse (-) for 5VDC input	34	PILC12V	I	Phase-C latch pulse (-) for 12VDC input
10	PILC24V	I	Phase-C latch pulse (-) for 24VDC input	35	PIL	I	Phase-C latch pulse (+)
11	DO_00-	O	Digital output 0 (-)	36	DO_01-	O	Digital output 1 (-)
12	DO_02-	O	Digital output 2 (-)	37	DO_03-	O	Digital output 3 (-)
13	DICOM	I	Digital input common	38	DICOM	I	Digital input common
14	DI_00	I	Digital input 0	39	DI_01	I	Digital input 1 (shared with pulse latch input)
15	DI_02	I	Digital input 2	40	DI_03	I	Digital input 3
16	DI_04	I	Digital input 4	41	DI_05	I	Digital input 5
17	DI_06	I	Digital input 6	42	DI_07	I	Digital input 7
18	DO_04-	O	Digital output 4 (-)	43	DO_05-	O	Digital output 5 (-)
19	DO_06-	O	Digital output 6 (-)	44	DO_07-	O	Digital output 7 (-)
20	-	-	-	45	-	-	-
21	DO_00+	O	Digital output 0 (+)	46	DO_01+	O	Digital output 1 (+)
22	DO_02+	O	Digital output 2 (+)	47	DO_03+	O	Digital output 3 (+)
23	DO_04+	O	Digital output 4 (+)	48	DO_05+	O	Digital output 5 (+)
24	DO_06+	O	Digital output 6 (+)	49	DO_07+	O	Digital output 7 (+) (shared with position agreement 'COIN' signal)
25	-	-	-	50	-	-	-

I = Input, O = Output, P = Power

# 6. Accessories: Terminal Block

## Terminal Block for Sigma-5

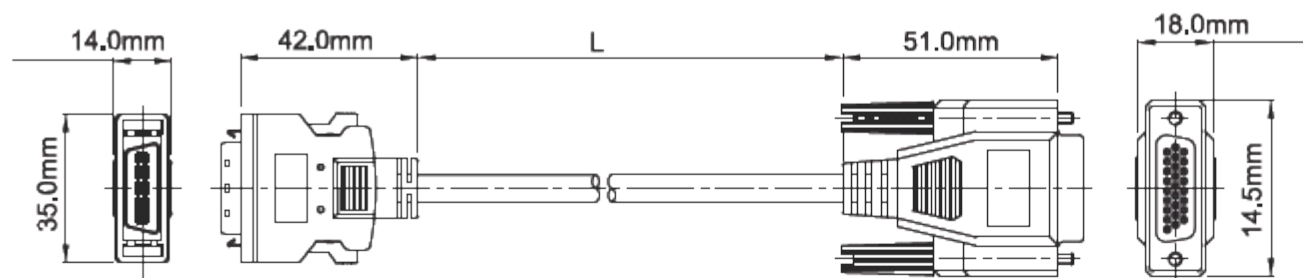

CABLE SPECIFICATION (mm)	
OUTER DIAMETER	6.5 +/- 0.2mm
BENDING RADIUS	6 x O.D. MINIMUM 15 x O.D. FOR LONG TERM RELIABILITY

ITEM#	L = LENGTH (mm)
SBK-U-VBA-A5	500 +/- 38.1
SBK-U-VBA-01	1000 +/- 38.1
SBK-U-VBA-03	3000 +/- 38.1

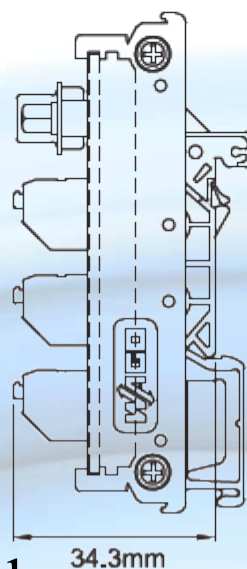
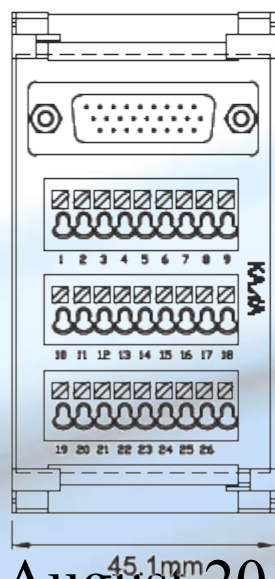



# 6. Accessories: Terminal Block

## Terminal Block for Sigma-5

### Layout

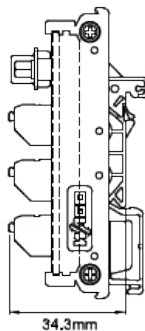
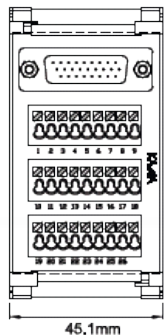

Pin No.	SGDV Mechatrolink-II type / SGDV Option type	
	Signal	Function
1	/BK+ (/SO1+)	Brake interlock output (+) (General purpose output 1 (+))
2	/BK- (/SO1-)	Brake interlock output (-) (General purpose output 1 (-))
3	ALM+	Servo alarm output (+)
4	ALM-	Servo alarm output (-)
5	-	
6	+24VIN	Control power supply for sequence signal input
7	P-OT (/SI1)	Forward run prohibited input (General purpose input 1)
8	N-OT (/SI2)	Reverse run prohibited input (General purpose input 2)
9	/DEC (/SI3)	Zero-point return deceleration switch input (General purpose input 3)
10	/EXT1 (/SI4)	External latch signal 1 input (General purpose input 4)
11	/EXT2 (/SI5)	External latch signal 2 input (General purpose input 5)
12	/EXT3 (/SI6)	External latch signal 3 input (General purpose input 6)
13	/SI0	General purpose input 0
14	BAT (+)	Battery (+) input
15	BAT (-)	Battery (-) input
16	SG	Signal ground
17	PAO	Phase-A pulse output (+)
18	/PAO	Phase-A pulse output (-)
19	PBO	Phase-B pulse output (+)
20	/PBO	Phase-B pulse output (-)
21	PCO	Phase-C pulse output (+)
22	/PCO	Phase-C pulse output (-)
23	/SO2+	General purpose output 2 (+)
24	/SO2-	General purpose output 2 (-)
25	/SO3+	General purpose output 3 (+)
26	/SO3-	General purpose output 3 (-)

Note: General purpose input and output signals are shown with their default signals assigned - signal assignment may have been changed by parameter

## 7. Installation MP2600iec

Mounting Kit: SGDV-OZC01A

- A mounting kit is required to connect the Option Card on Sigma-5.
- Fix the mounting plate (F) with the two screws (G)!

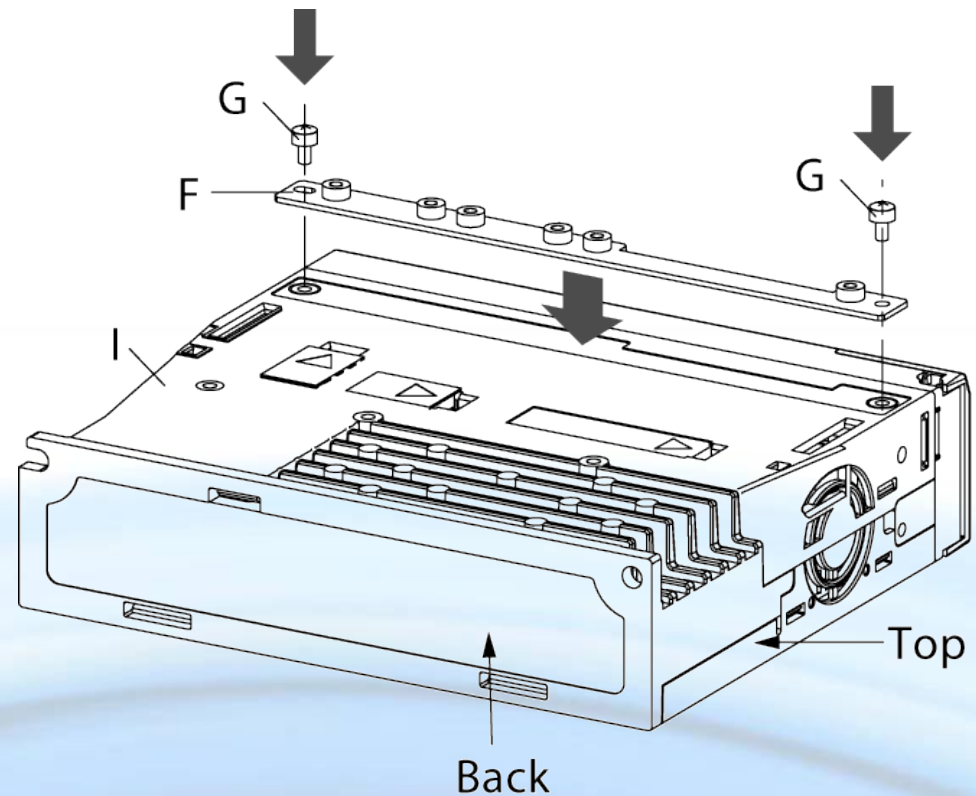

## 7. Installation MP2600iec

- Simply snap in the command option card (A) and fix it with 5 screws!

Insert the board connector firmly into the connector port.

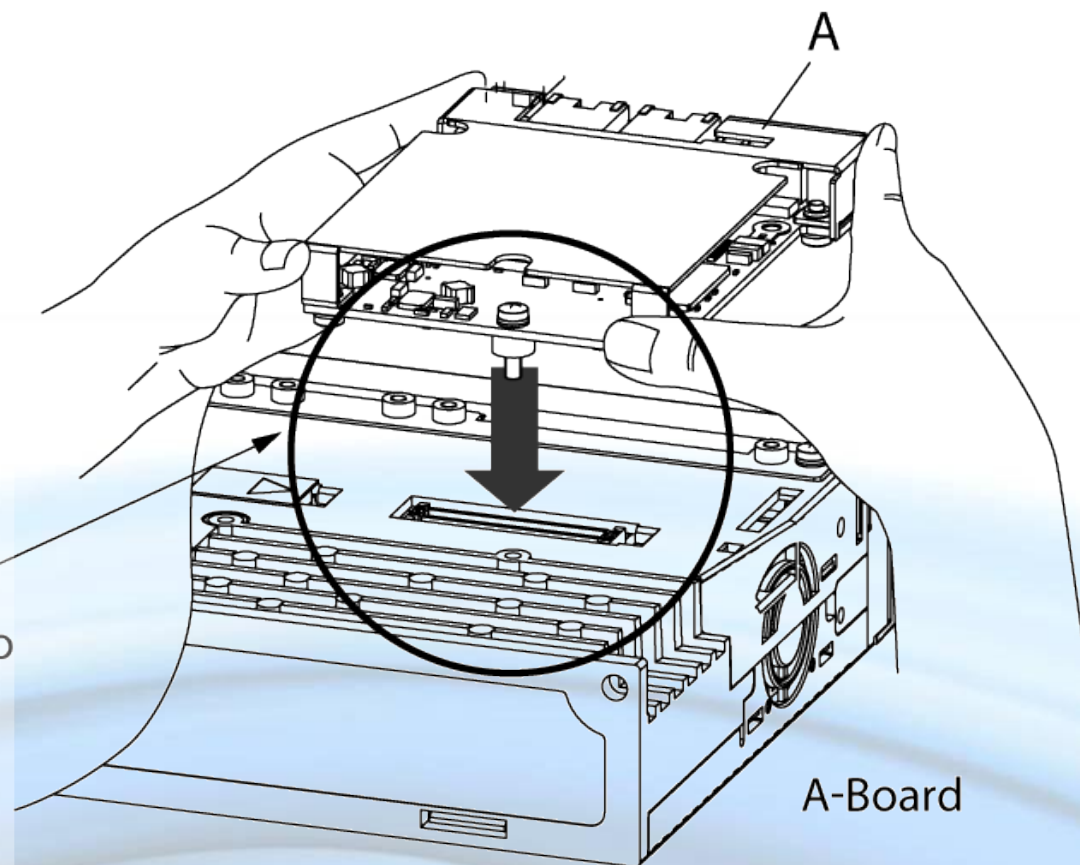

## 7. Installation MP2600iec

- Attach the cover (H) over the command option PCB

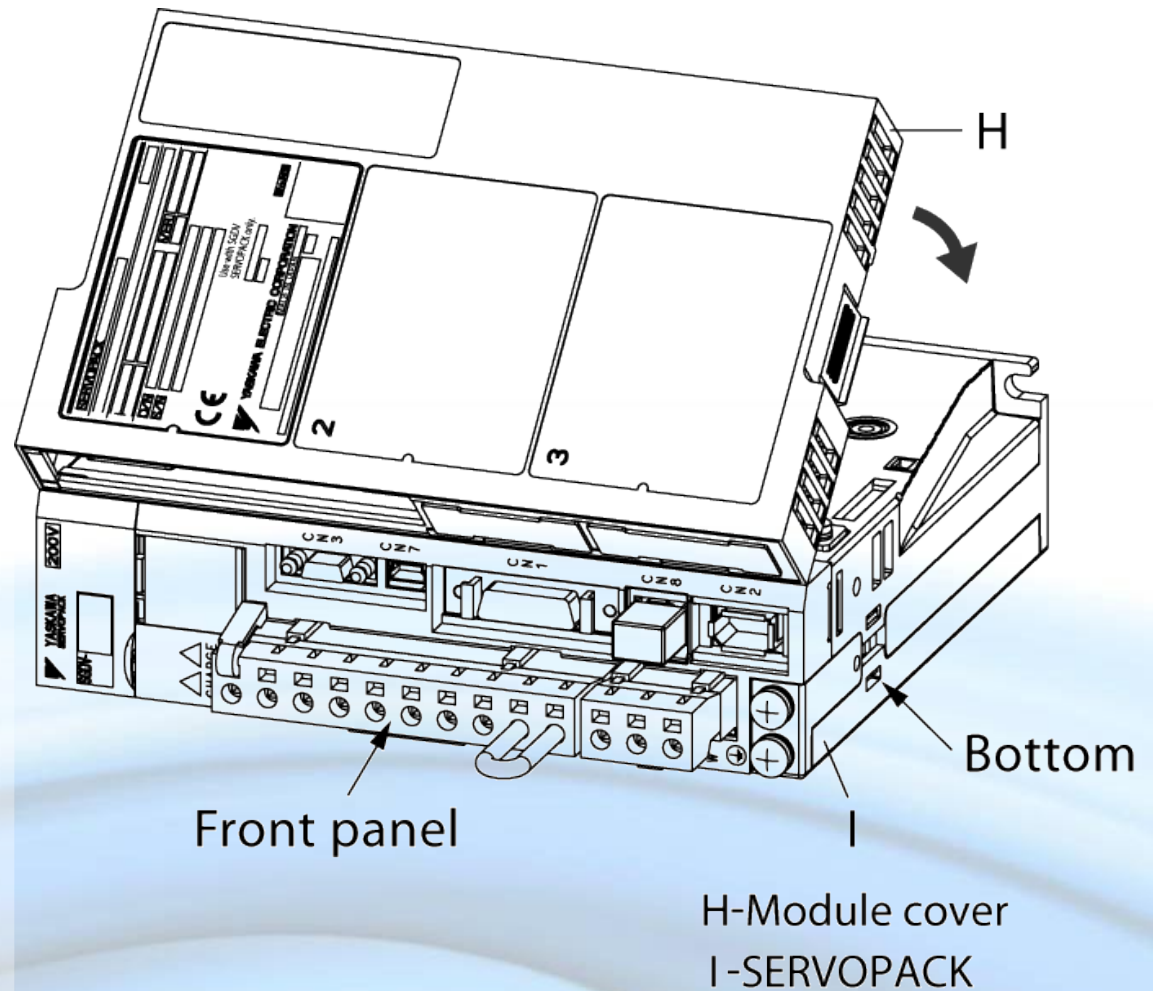

## 8. Summary MP2600iec SGDV-OCC02A

- Hardware:
  - External Encoder (RS422 compatible pulse counter)
  - Programming standards IEC 61131/PLCopen
  - 2 x 100base TX Ethernet
  - 8 x programmable digital Inputs/Outputs
  - 1 x analogue Input/Output
  - Latch Inputs
- Functions
  - Point-to-Point Positioning
  - E-CAM
  - Electronic Gearing
  - Homing

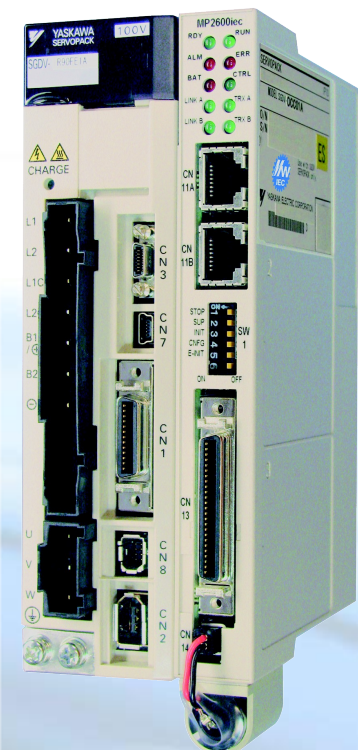







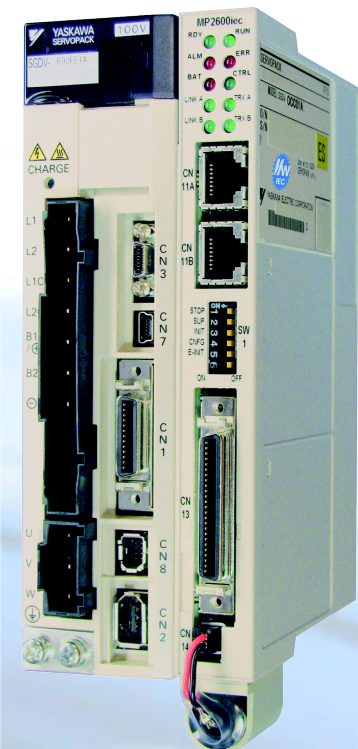

## 8. Summary MP2600iec SGD V-OCC02A

### 1.5 Axis Motion Controller

- Order code **VMK-U-MP26A01R001**
  - MP2600iec: SGD V-OCA01A
  - Mounting kit: SGD V-OZC01A
- Servopack: SGD V-xxxXExA
  - FW Version  $\geq 21$
- Engineering Tool
  - MotionWorks IEC Express MWiec Ver. 1.2.3.12
  - MotionWorks IEC Professional Pro Ver. 1.2.3.12
- Communication
  - Web Interface
  - OPC Server
  - EtherNet/IP
  - Modbus/TCP



-  **YEU MP2600iec Launch Package**
  -  Accessories
  -  Application Notes
  -  Application Overviews
  -  Documents
  - +  eLV
  -  Sell Sheets
  -  Software
  -  Technical Notes

