

MOTOMAN PL320

Palletizing & Handling with the PL-series



With over 1400 cycles per hour, the fast and powerful 4-axis MOTOMAN PL320 robot offers top performance for box, carton and bag palletizing for end-of-line packaging and logistics applications.

The optimized kinematic structure of the PL320 provides even better stability and higher max. payload capacity of 190 kg compared to the predecessor model. The superior working range with a maximum reach of 3,159 mm and an achievable stacking height of over 2,600 mm is perfect for all kinds of palletizing tasks. The MOTOMAN PL320 is very compact, has a slim small footprint design, and does not require a heavy counterweight balancer.

Media cables for grippers can be routed – protected and collision-free – through all axes and the hollow wrist.

The MOTOMAN PL320 is equipped with the latest Yaskawa Sigma7 Drive Technology and the compact YRC1000 high-performance controller.

Ideal is the combination with the optional Functional Safety Unit (FSU) for safeguarding compact working areas, or with MotoLogix® for easy programming of the robot via PLC function blocks.

KEY BENEFITS

- High cycle time performance: >1400 cycles/hour with full payload (400 mm – 2000 mm – 400 mm motion pattern)
- New Sigma7 servo motors → high accelerations, speed, energy efficiency
- High payload: max. 320 kg
- Large working range: 3159 mm
- Compact and slim design, no counterweight balancer
- Internal cable and wire routing
- Advanced functional safety (FSU) with YRC1000 controller
- Programmable by PLC function blocks via MotoLogix software interface
- Dust and liquid proof wrist design (IP54/67)

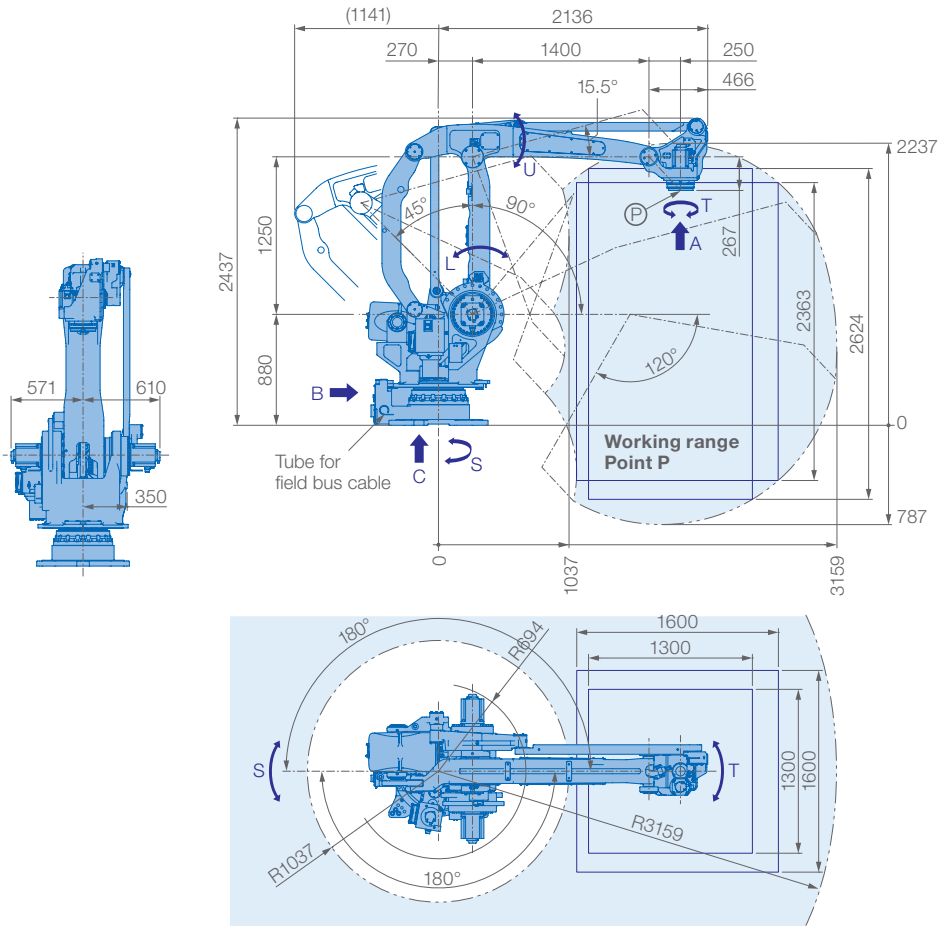

View A

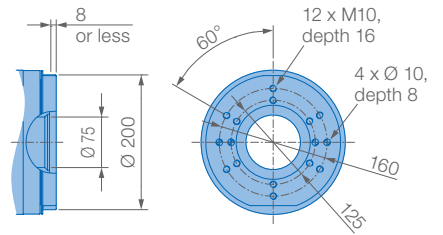

View B

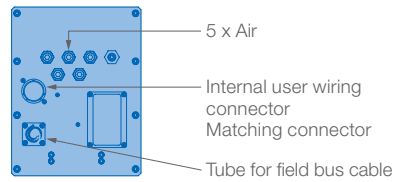

View C

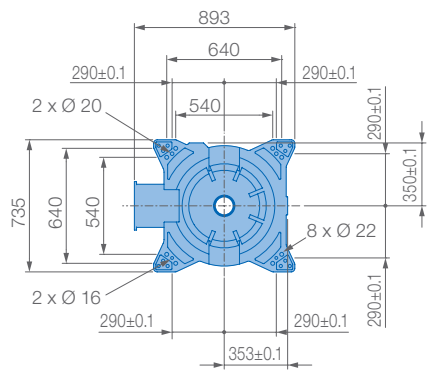

Allowable wrist load

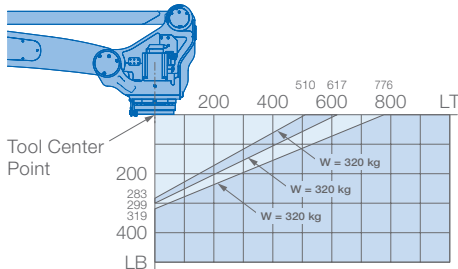

Mounting option: Floor
IP Protection: IP54 (body), IP67 (wrist)



Specifications PL320						
Axes	Maximum motion range [°]	Maximum speed [°/s]	Allowable moment [Nm]	Allowable moment of inertia [kg · m ²]	Controlled axes	4
S	±180	120	-	-	Max. payload [kg]	320
L	+90/-45	110	-	-	Repeatability [mm]	±0.05
U	+15.5/-120	110	-	-	Max. working range R [mm]	3159
R	-	-	-	-	Temperature [°C]	0 to +45
B	-	-	-	-	Humidity [%]	20 - 80
T	±360	300	-	160	Weight [kg]	1680
					Max. connected load [kVA]	9.5

Yaskawa Europe GmbH

Robotics Division
Yaskawastraße 1
85391 Allershausen
Germany

Tel. +49 (0) 8166 90-0
robotics@yaskawa.eu.com
www.yaskawa.eu.com

YR-1-04LXH320-A00
A-02-2021, A-No. 215064