

# KRD3

- ANALOGUE CONTROL OUTPUT
- 8 SEGMENTS PROGRAMMER
- INDEPENDENT TIMER
- WORKING HOURS COUNTER

*evolution*

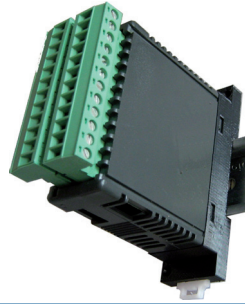

**FEATURES**

KRD3	
<b>INPUTS</b>	
Input	Thermocouples: J (-50... +1000°C/-58... 1832°F), K (-50... +1370°C/-58... 2498°F), S/R (-50... +1760°C/-58... 3200°F), T (-70... +400°C/-94... 752°F) Infrared sensors: J or K Thermoresistances: 3 wires Pt 100 and 2 wires Pt 1000 (-200... 850°C/-328... 1562°F) Linear signals: 0/12... 60mV, 0/4... 20mA, 0/1... 5V, 0/2... 10V
Accuracy	± 0.5% span ±1 digit, (±1% span ±1 digit for T/c S type)
Digital input	1, always on board
<b>OUTPUTS</b>	
Up to 4	OUT 1: Relay SPDT 4A/240 Vac or voltage to drive SSR 13V max. @ 1mA, 10.5V min. @ 15mA ±10% or analogue galvanically isolated 0/4... 20 mA, 0/2... 10V (optional)
	OUT 2: Relay SPST-NO 2A/240 Vac or voltage to drive SSR 13V max. @ 1mA, 10.5V min. @ 15mA ±10%
	OUT 3: Relay SPST-NO 2A/240 Vac or voltage to drive SSR 13V max. @ 1mA, 10.5V min. @ 15mA ±10%
	OUT 4 programmable: voltage output to drive SSR 13V max. @ 1mA, 10.5V min. @ 22mA ±10% or transmitter supply
<b>FUNCTIONAL</b>	
Control	PID single or double action, ON/OFF, ON/OFF with Neutral Zone Autotuning and Selftuning algorithms, Overshoot control
Alarms	3 alarms programmable as absolute, deviation, band
Set Point	4 programmable Set Points
Signal retransmission	Measuring or Set Point retransmission
Serial communication	TTL (standard) + RS485 (optional), ModBus RTU protocol
Baud rate	1200... 38400 baud
Working hours counters	A cumulative non-erasable counter and a second one resettable with alarm
Wattmeter function	Instantaneous power, time consumption
EVOogreen	Stand-by mode of display, selectable
Programmer (optional)	Up to 8 segments with guaranteed soak
Timer (optional)	Independent with 5 function modes
<b>GENERAL</b>	
Power supply	24 Vac/Vdc ± 10%, 100... 240 Vac/Vdc -15%/+ 10% (50/60 Hz)
Power consumption	7 VA max
Dimensions / Weight	78 x 35 mm - 200 g
Mounting	On OMEGA DIN A rail or on wall
Connections	16 screw terminals 2.5 mm <sup>2</sup> (AWG22... AWG14) fix, plug-in or clamp type
Front protection degree	IP 20
Operating / storage temperature	0... 50°C (32... 122°F)/-20... +70°C (-4... 158°F)
Operating humidity	20... 95 RH% without condensation
Conformity	EN 61010-1, EN 61326

# HOW TO ORDER

To compose the part number, pls. choose one of the option for each variable

KRD3	CODE
<b>VERSION</b>	
Controller	-
Controller + Timer	T
Controller + Timer + Programmer	P
<b>POWER SUPPLY</b>	
24 Vac/Vdc	L
100... 240 Vac	H
<b>INPUT</b>	
TC, RTD, mA, V, mV/digital input	C
<b>OUT 1</b>	
Relay SPDT 4A	R
Vdc for SSR driving	0
0/4... 20 mA, 0/2... 10V galvanically isolated	I
<b>OUT 2</b>	
Relay SPST-NO 2A	R
Vdc for SSR driving	0
Relay SPST-NO 2A for Servomotor	M
Not available	-
<b>OUT 3</b>	
Relay SPST-NO 2A	R
Vdc for SSR driving	0
Relay SPST-NO 2A for Servomotor	M
Not available	-
<b>OUT 4</b>	
Digital input or digital output or transmitter supply	D
<b>RS485</b>	
Available (Standard)	S
Not available (Optional)	-
<b>CONNECTION</b>	
Plug-in screw type	E
Plug-in screw type, fix part only	N
Clamp type	M
Fix screw type (standard)	-

# CONNECTIONS

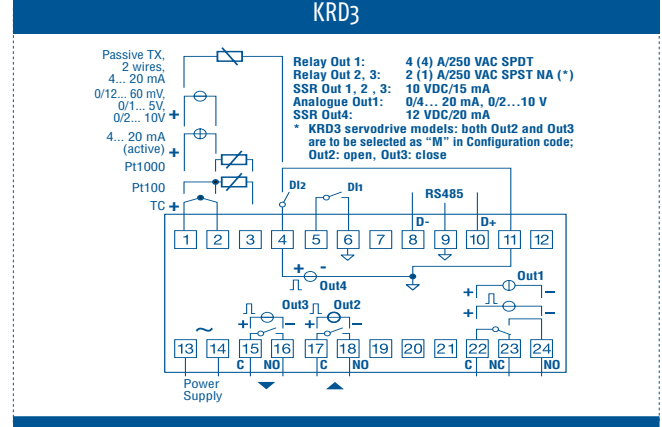

# DIMENSIONS

