

# MOTOMAN GP50

Handling & General Applications  
with the GP-series



The MOTOMAN GP50 is a versatile, high speed 6-axis robot offering superior performance in material handling, machine tending, processing and dispensing applications.

Due to its compact design, the GP50 can be placed close to machines for loading and unloading of parts.

#### KEY BENEFITS

- Fast, flexible and reliable
- Ideal for a variety of applications, multi-purpose robot
- Robot with sleek design that requires minimal installation space
- 50 kg payload

Controlled by  
YRC1000

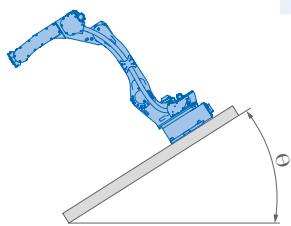
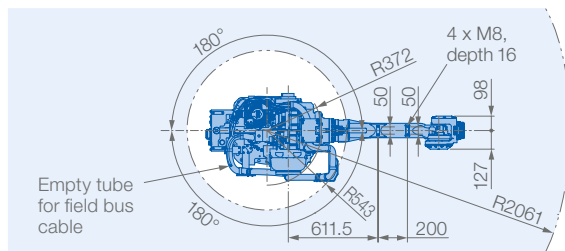
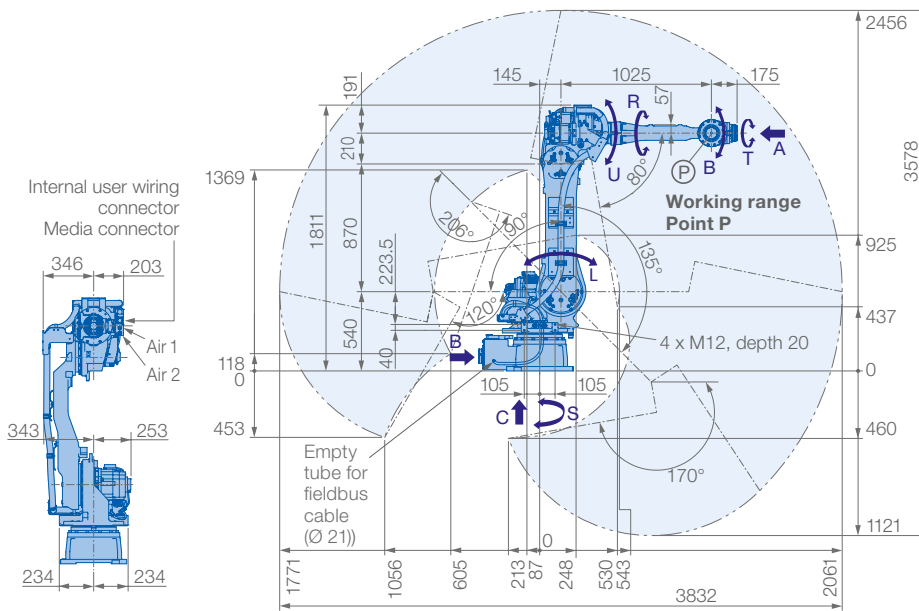

Robot installation angle $\theta$ [deg.]	S-axis operating range [deg.]
$0 \leq \theta \leq 30$	$\pm 180$ (Standard)
$30 < \theta \leq 35$	$\pm 60$
$35 < \theta \leq 45$	$\pm 45$
$45 < \theta$	$\pm 30$

**Allowable wrist load**

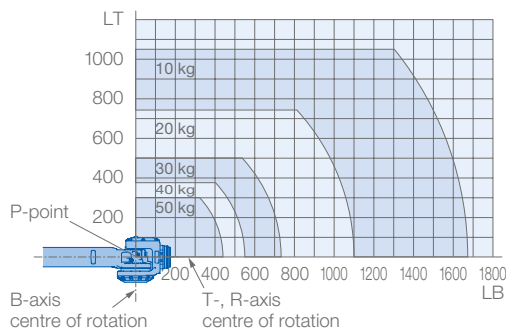

**View A**

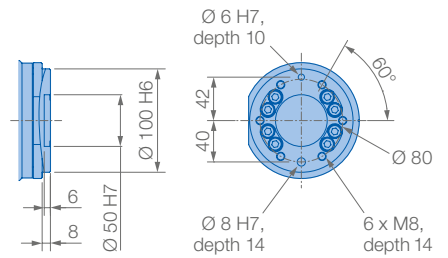

**View B**

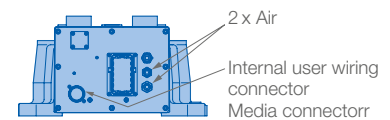

**View C**

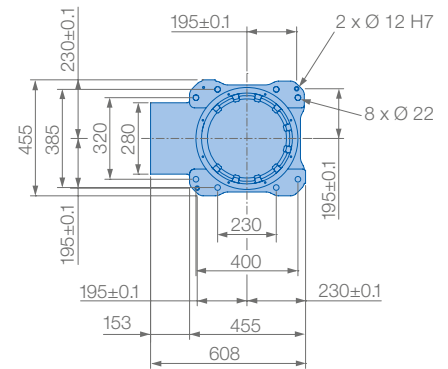

Mounting options: Floor, ceiling, wall, tilt\*

**Please notice wall mounting option:**  
±30° S-axis limit

**Please notice ceiling mounting option:**  
Please notice working range of B-axis

**Please notice tilted robot:**  
0°–90° limitation of S-axis, details on request

Protection class: IP54/67

**Please notice:** Just valid for body/wrist, connector base not protected

\*tilt with condition of angle – see table left side

Specifications GP50					
Axes	Maximum motion range [°]	Maximum speed [°/sec.]	Allowable moment [Nm]	Allowable moment of inertia [kg · m <sup>2</sup> ]	Controlled axes
S	±180	180	–	–	6
L	+135/–90	178	–	–	Max. payload [kg]
U	+206/–80	178	–	–	Repeatability [mm]
R	±360	250	216	28	Max. working range R [mm]
B	±125	250	216	28	Temperature [°C]
T	±360	360	147	11	Humidity [%]
					Weight [kg]
					Power supply, average [KVA]