

# MOTOMAN GP215

Handling & General Applications  
with the GP-series



The 6-axis MOTOMAN GP215 is a versatile, high speed robot offering superior performance for a variety of applications, like material handling, machine and press tending.

Despite of providing a high payload of 215 kg and the wide motion range of 2912 mm, the MOTOMAN GP215 was designed with a width of 816 mm, therefore valuable floor space can be saved.

The vibration control system uses higher axis operation speed and speed reducer rigidity to allow fast acceleration of short movements. By reducing cycle times, this system realises high increases in productivity.

## KEY BENEFITS

- Fast, flexible and powerful
- High payload: 215 kg
- Wide motion range: 2912 mm
- Maximum performance using minimal floor space

Controlled by  
YRC1000

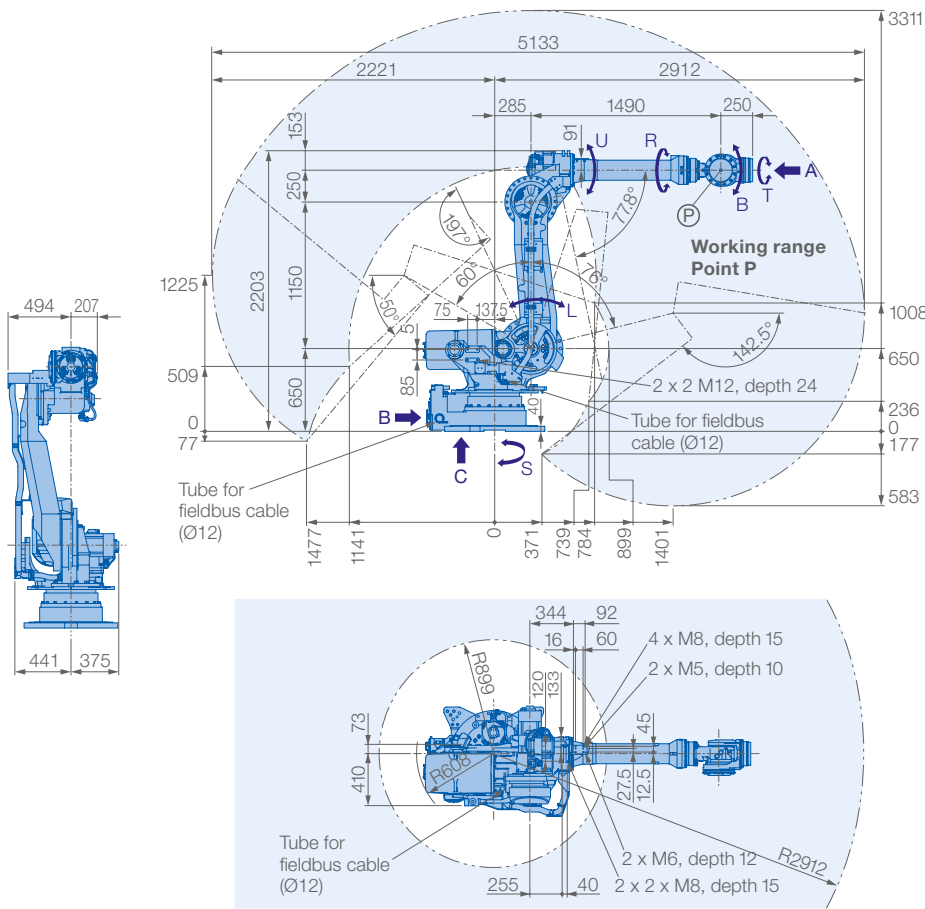

View A

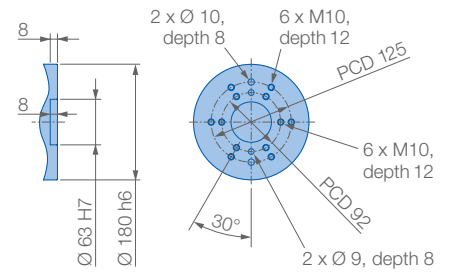

View B

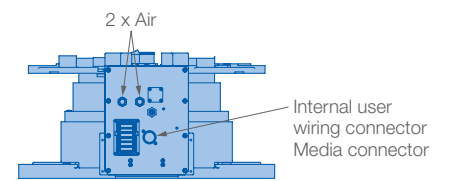

View C

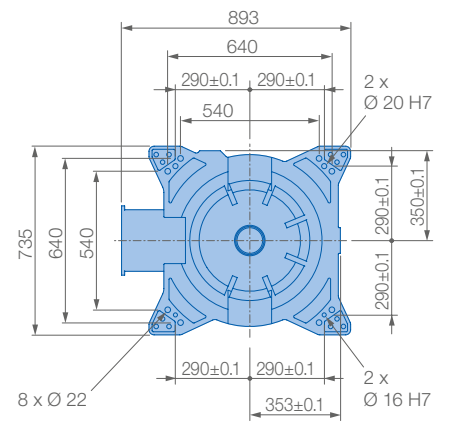

Mounting option: Floor  
Protection class: IP54/67

Allowable wrist load

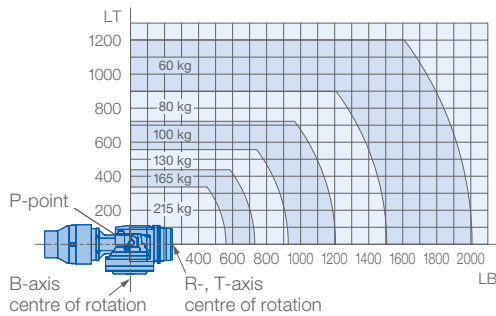

Specifications GP215						
Axes	Maximum motion range [°]	Maximum speed [°/sec.]	Allowable moment [Nm]	Allowable moment of inertia [kg · m <sup>2</sup> ]	Controlled axes	6
S	±180	100	-	-	Max. payload [kg]	215
L	+76/-60	90	-	-	Repeatability [mm]	±0.2
U	+197/-77.8	97	-	-	Max. working range R [mm]	2912
R	±360	120	1176	317	Temperature [°C]	0 to +45
B	±125	120	1176	317	Humidity [%]	20 - 80
T	±360	190	710	200	Weight [kg]	1340
					Power supply, average [KVA]	5.0