

MOTOMAN GP280

Handling & General Applications
with the GP-series



The 6-axis MOTOMAN GP280 is a versatile, high speed robot offering superior performance for a variety of applications, like material handling, machine and press tending.

The GP280 offers a large work envelope of 2446 mm and a high moment of inertia ratings. Fast axial speeds and acceleration reduce cycle times and increase production output. The compact, slim design allows the robot to reach into confined spaces, improving system productivity.

The MOTOMAN GP280 is available with the PLd Category 3 Functional Safety Unit (FSU).

KEY BENEFITS

- Fast, flexible and powerful
- Compact design allows maximum performance using minimal floor space
- Max. payload of 280 kg
- Max. working range of 2446 mm
- Enhanced safety functions

Controlled by
YRC1000

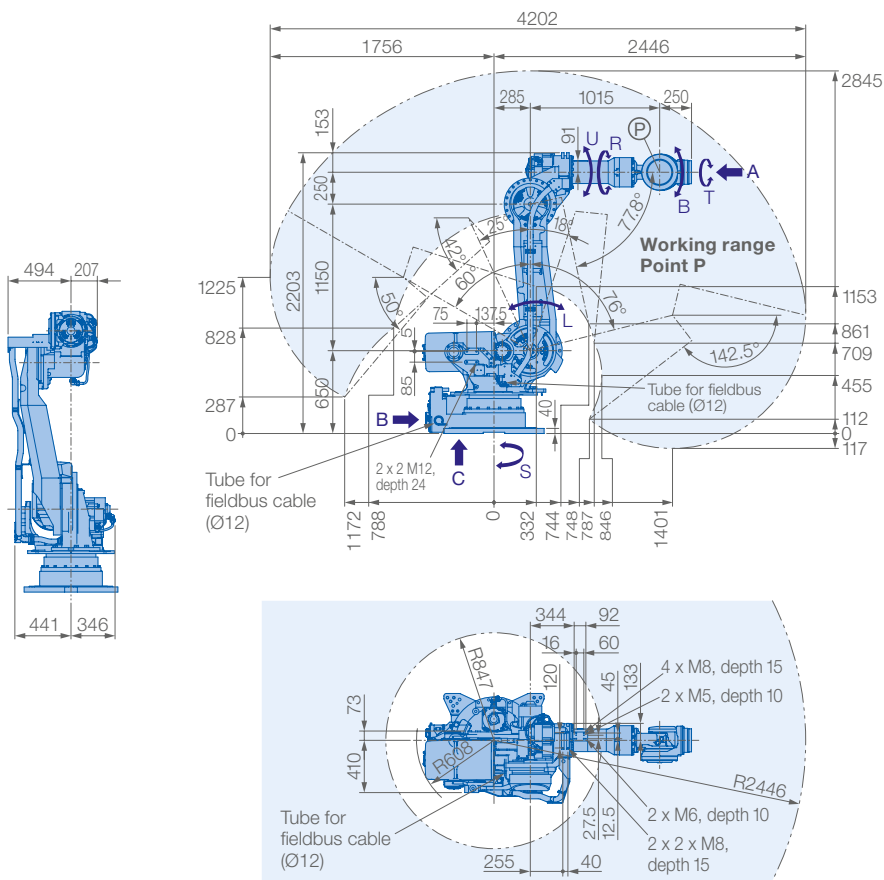

View A

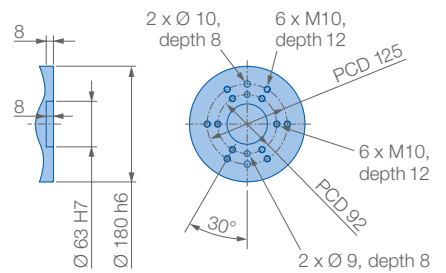

View B

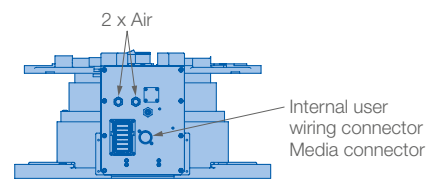

View C

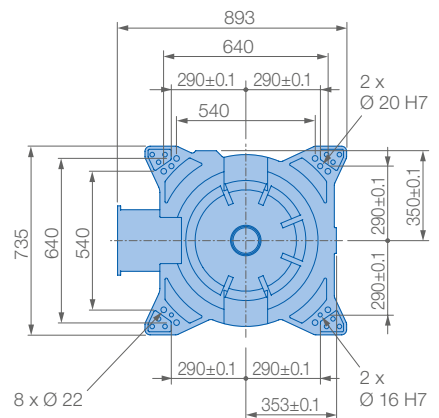

Mounting option: Floor
Protection class: IP54/67

Allowable wrist load

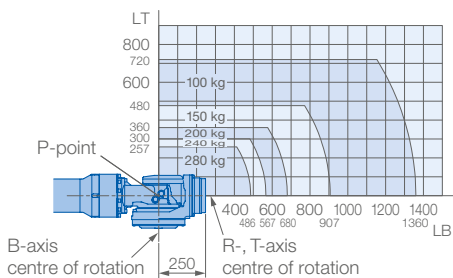

Specifications GP280						
Axes	Maximum motion range [°]	Maximum speed [°/sec.]	Allowable moment [Nm]	Allowable moment of inertia [kg · m ²]	Controlled axes	6
S	±180	90	-	-	Max. payload [kg]	280
L	+76/-60	80	-	-	Repeatability [mm]	±0.2
U	+197/-77.8	90	-	-	Max. working range R [mm]	2446
R	±360	115	1333	142	Temperature [°C]	0 to +45
B	±125	110	1333	142	Humidity [%]	20 - 80
T	±360	190	706	79	Weight [kg]	1300
					Power supply, average [KVA]	5.0