

MOTOMAN PL800

Palletizing & Handling with the PL-series



The most powerful 4-axis robot of the PL-series is the MOTOMAN PL800 with a payload of 800 kg. This palletizer offers high performance for box, carton and pack palletizing in versatile end-of-line packaging and logistics applications. The large working range with a maximum reach of 3159 mm and an achievable stacking height of over 2624 mm allows versatile use across all palletizing applications.

Media cables for grippers can be routed – protected and collision-free – through all axes and the hollow wrist.

The MOTOMAN PL800 is equipped with the latest energy-saving Yaskawa Sigma7 Drive Technology and the compact YRC1000 high-performance controller.

Ideal is the combination with the optional Functional Safety Unit (FSU) for safeguarding compact working areas, or with MotoLogix for easy programming of the robot via PLC function blocks.

KEY BENEFITS

- Strongest robot in the PL series: 800 kg payload
- New Sigma7 servo motors → high accelerations, speed, energy efficiency
- Large working range: 3159 mm
- Robust and flexible
- Compact and slim design
- Identical footprint as other robots of the PL-series
- Internal cable and wire routing
- Advanced functional safety (FSU) with YRC1000 controller
- Programmable by PLC function blocks via MotoLogix software interface

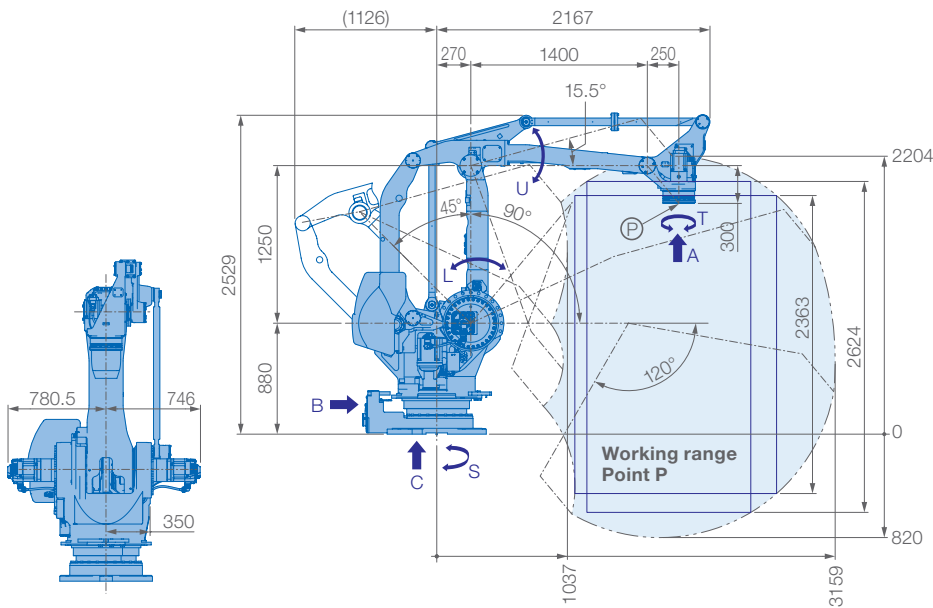

View A

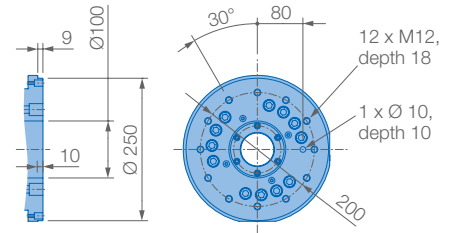

View B

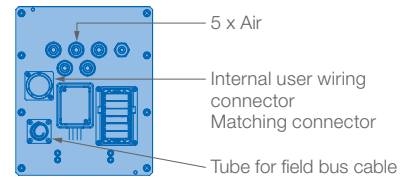

View C

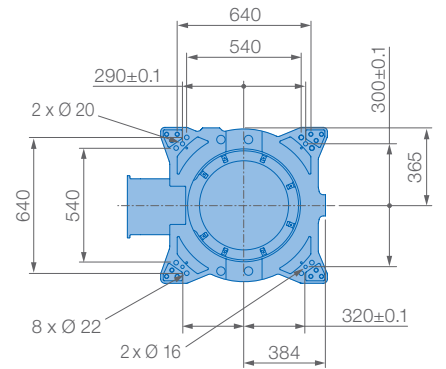

Mounting option: Floor
IP Protection: IP54

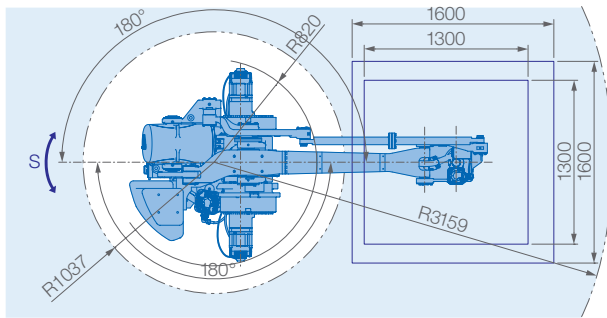

Allowable wrist load

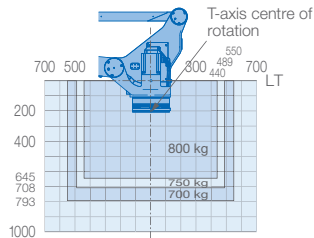

Specifications PL800

Axes	Maximum motion range [°]	Maximum speed [°/s]	Allowable moment [Nm]	Allowable moment of inertia [kg · m ²]	Controlled axes	
					Max. payload [kg]	
S	±180	65	-	-	800	4
L	+90/-45	65	-	-	±0,05	
U	+15.5/-120	65	-	-	3159	
R	-	-	-	-	0 to +45	
B	-	-	-	-	20 - 80	
T	±360	125	-	550	2560	
					8.0	

Yaskawa Europe GmbH

Robotics Division
Yaskawastraße 1
85391 Allershausen
Germany

Tel. +49 (0) 8166 90-0
robotics@yaskawa.eu.com
www.yaskawa.eu.com

YR-1-04LXH800-A00
A-04-2021, A-No. 215068

All drawing dimensions in mm. Technical data may be subject to change without previous notice. Please request detailed drawings at robotics@yaskawa.eu.com.