

VIPA Networking Solutions

ENS | 910-1ENx0 | Manual

HB175 | ENS | 910-1ENx0 | GB | 16-10

Ethernet Switches EN5-R/EN8-R

VIPA GmbH
Ohmstr. 4
91074 Herzogenaurach
Telephone: +49 9132 744-0
Fax: +49 9132 744-1864
Email: info@vipa.com
Internet: www.vipa.com

Table of contents

1	General	4
1.1	Copyright © VIPA GmbH	4
1.2	About this manual.....	5
1.3	Safety information.....	6
2	Hardware Installation	8
2.1	Panel Layout.....	8
2.2	Mounting Dimensions.....	10
2.3	DIN-Rail Mounting.....	11
2.4	Wall Mounting (optional).....	11
2.5	ATEX Information.....	12
2.6	Wiring Requirements.....	13
2.7	Grounding the Switch.....	13
2.8	Wiring the Redundant Power Inputs.....	14
2.9	Communication Connections.....	14
2.9.1	10/100BaseT(X) Ethernet Port Connection.....	14
2.9.2	100BaseFX Ethernet Port Connection.....	15
2.10	Redundant Power Inputs.....	17
2.11	DIP Switch Settings.....	17
2.12	LED Indicators.....	17
2.13	Auto MDI/MDI-X Connection.....	18
2.14	Dual Speed Functionality and Switching.....	18
2.15	Switching, Filtering, and Forwarding.....	18
2.16	Switching and Address Learning.....	18
2.17	Specifications.....	19

1 General

1.1 Copyright © VIPA GmbH

All Rights Reserved

This document contains proprietary information of VIPA and is not to be disclosed or used except in accordance with applicable agreements.

This material is protected by the copyright laws. It may not be reproduced, distributed, or altered in any fashion by any entity (either internal or external to VIPA), except in accordance with applicable agreements, contracts or licensing, without the express written consent of VIPA and the business management owner of the material.

For permission to reproduce or distribute, please contact: VIPA, Gesellschaft für Visualisierung und Prozessautomatisierung mbH Ohmstraße 4, D-91074 Herzogenaurach, Germany

Tel.: +49 9132 744 -0

Fax.: +49 9132 744-1864

E-Mail: info@vipa.de

<http://www.vipa.com>



Every effort has been made to ensure that the information contained in this document was complete and accurate at the time of publishing. Nevertheless, the authors retain the right to modify the information.

This customer document describes all the hardware units and functions known at the present time. Descriptions may be included for units which are not present at the customer site. The exact scope of delivery is described in the respective purchase contract.

CE Conformity Declaration

Hereby, VIPA GmbH declares that the products and systems are in compliance with the essential requirements and other relevant provisions. Conformity is indicated by the CE marking affixed to the product.

Conformity Information

For more information regarding CE marking and Declaration of Conformity (DoC), please contact your local VIPA customer service organization.

Trademarks

VIPA, SLIO, System 100V, System 200V, System 300V, System 300S, System 400V, System 500S and Commander Compact are registered trademarks of VIPA Gesellschaft für Visualisierung und Prozessautomatisierung mbH.

SPEED7 is a registered trademark of profichip GmbH.

SIMATIC, STEP, SINEC, TIA Portal, S7-300 and S7-400 are registered trademarks of Siemens AG.

Microsoft and Windows are registered trademarks of Microsoft Inc., USA.

Portable Document Format (PDF) and Postscript are registered trademarks of Adobe Systems, Inc.

All other trademarks, logos and service or product marks specified herein are owned by their respective companies.

Information product support

Contact your local VIPA Customer Service Organization representative if you wish to report errors or questions regarding the contents of this document. If you are unable to locate a customer service centre, contact VIPA as follows:

VIPA GmbH, Ohmstraße 4, 91074 Herzogenaurach, Germany

Telefax: +49 9132 744-1204

E-Mail: documentation@vipa.de

Technical support

Contact your local VIPA Customer Service Organization representative if you encounter problems with the product or have questions regarding the product. If you are unable to locate a customer service centre, contact VIPA as follows:

VIPA GmbH, Ohmstraße 4, 91074 Herzogenaurach, Germany

Tel.: +49 9132 744-1150 (Hotline)

E-Mail: support@vipa.de

1.2 About this manual**Objective and contents**

This manual describes the Teleservice module 910-1ENx0 from VIPA. It contains a description of the structure, project engineering and deployment.

Product	Order number	as of state: HW
EN5-R/EN8-R	910-1ENx0	01

Target audience

The manual is targeted at users who have a background in automation technology.

Structure of the manual

The manual consists of chapters. Every chapter provides a self-contained description of a specific topic.

- Guide to the document** The following guides are available in the manual:
- An overall table of contents at the beginning of the manual
 - References with page numbers
- Availability** The manual is available in:
- printed form, on paper
 - in electronic form as PDF-file (Adobe Acrobat Reader)
- Icons Headings** Important passages in the text are highlighted by following icons and headings:

**DANGER!**

Immediate or likely danger. Personal injury is possible.

**CAUTION!**

Damages to property is likely if these warnings are not heeded.



Supplementary information and useful tips.

1.3 Safety information

Applications conforming with specifications

The Teleservice module is constructed and produced for:

- communication and process control
- industrial applications
- operation within the environmental conditions specified in the technical data
- installation into a cubicle

**DANGER!**

This device is not certified for applications in
– in explosive environments (EX-zone)

Documentation

The manual must be available to all personnel in the

- project design department
- installation department
- commissioning
- operation

**CAUTION!**

The following conditions must be met before using or commissioning the components described in this manual:

- Hardware modifications to the process control system should only be carried out when the system has been disconnected from power!
- Installation and hardware modifications only by properly trained personnel.
- The national rules and regulations of the respective country must be satisfied (installation, safety, EMC ...)

Disposal

National rules and regulations apply to the disposal of the unit!

2 Hardware Installation

Overview

- The VIPA EN5-R/EN8-R series of industrial Ethernet switches are entry-level industrial 5 and 8-port Ethernet switches that support IEEE 802.3, IEEE 802.3u, and IEEE 802.3x with 10/100M, full/half-duplex, and MDI/MDIX auto-sensing.
- The EN5-R/EN8-R series provides 12/24/48 VDC (9.6 to 60 VDC)/ 18 to 30 VAC redundant power inputs that can be connected simultaneously to a live AC/DC power source. The switches are available with a standard operating temperature range from -10 to 60°C, or with a wide operating temperature range from -40 to 75°C, and IP30 metal housing makes them rugged enough for any harsh industrial environment.
- To provide greater versatility for use with applications from different industries, the EN5-R/EN8-R also allow users to enable or disable broadcast storm protection with DIP switches on the outer panel.
- The EN5-R/EN8-R switches can be easily installed with DIN-Rail mounting as well as distribution boxes. The DIN-rail mounting capability and IP30 metal housing with LED indicators make the plug-and-play EN5-R/EN8-R switches reliable and easy to use.



CAUTION!

This device complies with part 15 of FCC Rules. Operation is subject to the following two conditions: (1) This device may not cause harmful interference, and (2) this device must accept any interference received, including interference that may cause undesired operation.

2.1 Panel Layout

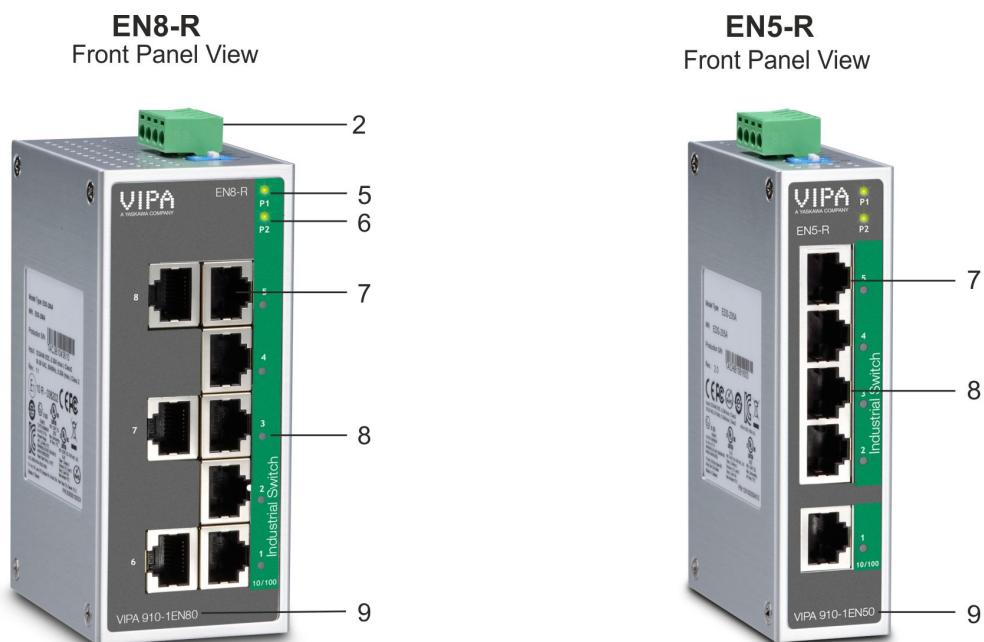

Top Panel View

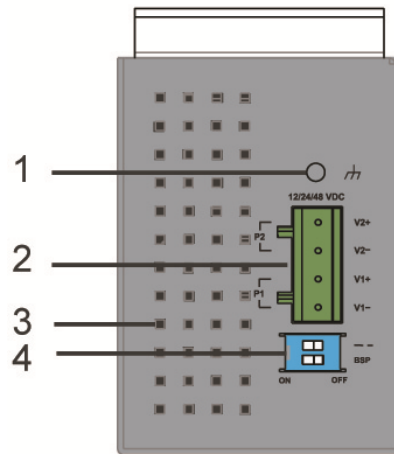

Top Panel View

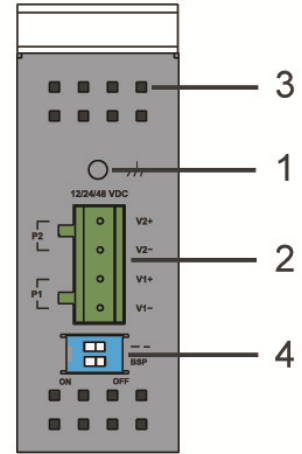

Rear Panel View

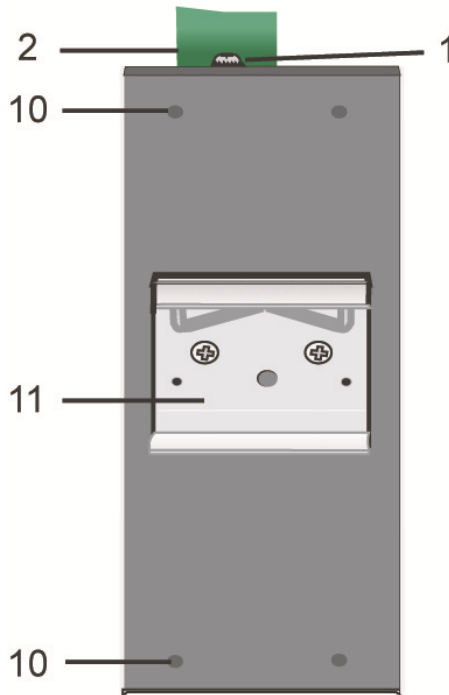

Rear Panel View

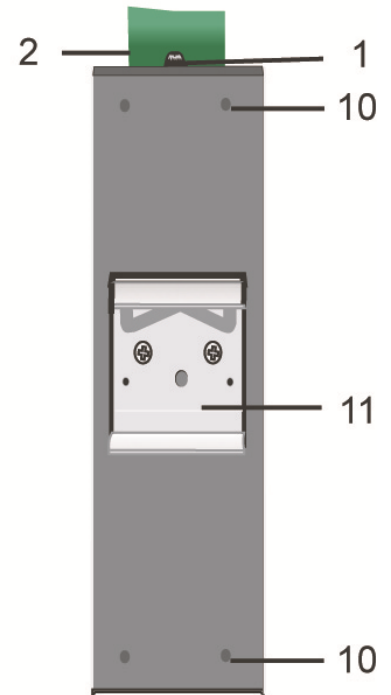

- 1 Grounding screw
- 2 Terminal block for power input P1/P2
- 3 Heat dissipation orifices
- 4 DIP switches
- 5 Power input P1 LED
- 6 Power input P2 LED
- 7 10/100BaseT(X) Port
- 8 TP port's 10/100 Mbps LED
- 9 Model Name
- 10 Screw hole for wall mounting kit
- 11 DIN-Rail Kit

2.2 Mounting Dimensions

EN5-R

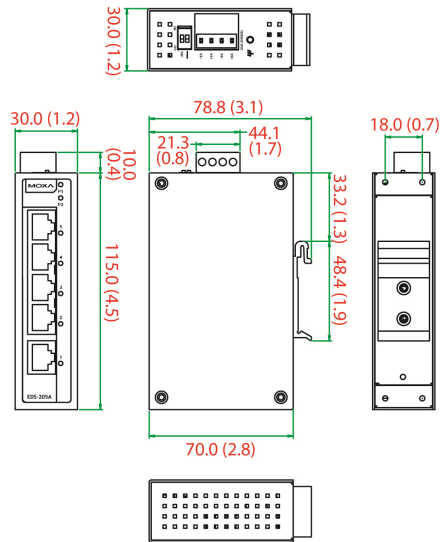

Unit = mm (inch)

EN8-R

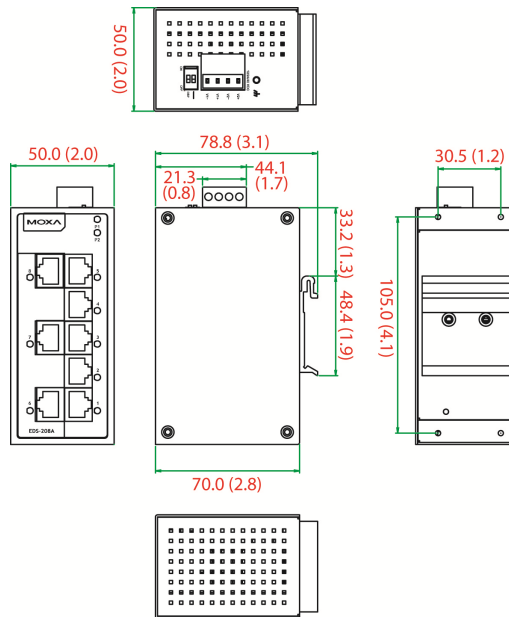

2.3 DIN-Rail Mounting

The aluminum DIN-Rail attachment plate should already be fixed to the back panel of the Switch when you take it out of the box. If you need to reattach the DIN-Rail attachment plate, make sure the stiff metal spring is situated towards the top, as shown in the following figures.

1. ▶ Insert the top of the DIN-Rail into the slot just below the stiff metal spring.

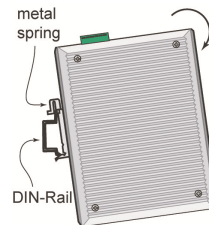

2. ▶ The DIN-Rail attachment unit will snap into place as shown.

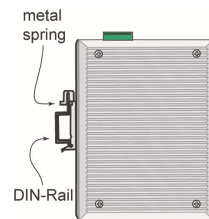

To remove the VIPA Switch from the DIN-Rail, simply reverse Steps 1 and 2.

2.4 Wall Mounting (optional)

For some applications, you will find it convenient to mount the Switch on the wall, as shown in the following figures.

1. ▶ Remove the aluminum DIN-Rail attachment plate from the Switch's rear panel, and then attach the wall mount plates with M3 screws, as shown in the diagram at the right.

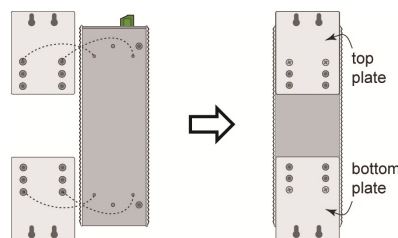

2. ▶ Mounting the Switch on the wall requires 4 screws. Use the switch, with wall mount plates attached, as a guide to mark the correct locations of the 4 screws. The heads of the screws should be less than 6.0 mm in diameter, and the shafts should be less than 3.5 mm in diameter, as shown in the figure at the right.

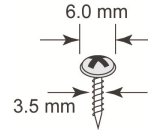

Before tightening the screws into the wall, make sure the screw head and shank size are suitable by inserting the screw into one of the keyhole-shaped apertures of the wall mounting plates.

Do not screw the screws in completely—leave about 2 mm to allow room for sliding the wall mount panel between the wall and the screws.

3. ▶ Once the screws are fixed in the wall, insert the four screw heads through the large parts of the keyhole-shaped apertures, and then slide the Switch downwards, as indicated. Tighten the four screws for added stability.

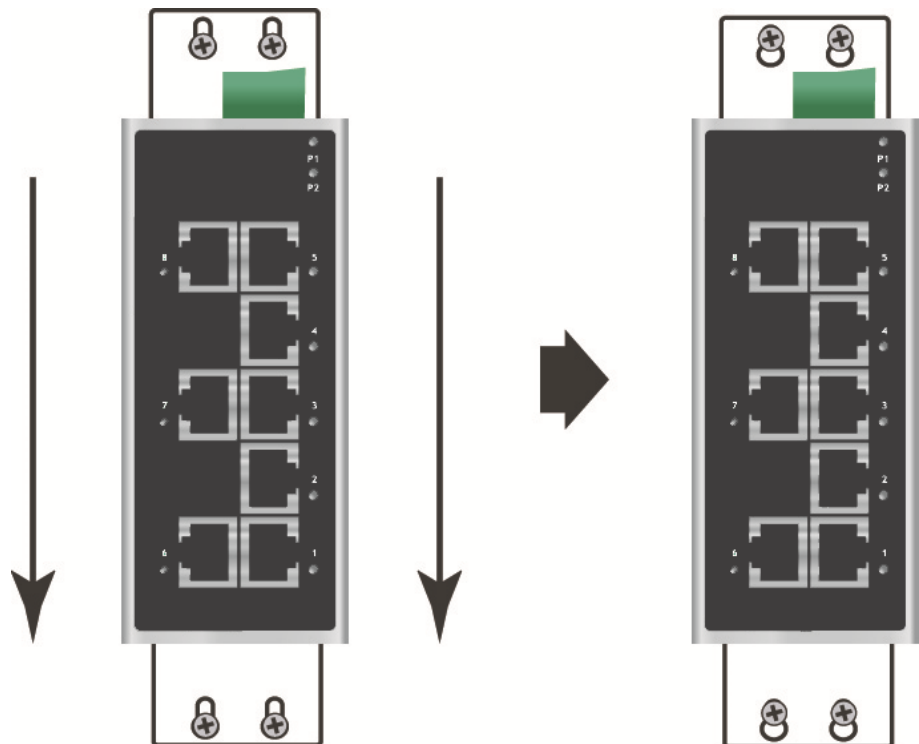

2.5 ATEX Information

- Certificate number DEMKO 10 ATEX 0909900X
- Ambient range (-40°C ≤ Tamb ≤ 75°C)
- Certification string (Ex nA nC IIC T4 Gc)

- Standards covered (EN 60079-0:2012, EN 60079-15:2010)
- The conditions of safe usage:
 - Subject devices are for use in ambient temperature $-40^{\circ}\text{C} \leq T_{\text{amb}} \leq +75^{\circ}\text{C}$.
 - Subject devices are to be installed in an IP54 enclosure.
 - Subject devices are for use in an area of not more than pollution degree 2 in accordance with IEC 60664-1.
 - Subject devices are to use Conductors suitable for use in an ambient temperature of 100°C must be used for the Power Supply Terminal.

2.6 Wiring Requirements



WARNING! **Safety First!**

Turn the power off before disconnecting modules or wires. The correct power supply voltage is listed on the product label. Check the voltage of your power source to make sure that you are using the correct voltage. Do NOT use a voltage greater than what is specified on the product label. These devices must be supplied by a SELV source as defined in the Low Voltage Directive 2006/95/EC and 2004/108/EC.



WARNING!

Calculate the maximum possible current in each power wire and common wire. Observe all electrical codes dictating the maximum current allowable for each wire size. If the current goes above the maximum ratings, the wiring could overheat, causing serious damage to your equipment.

Be sure to read and follow these important guidelines:

- Use separate paths to route wiring for power and devices. If power wiring and device wiring paths must cross, make sure the wires are perpendicular at the intersection point.
NOTE: Do not run signal or communications wiring and power wiring through the same wire conduit. To avoid interference, wires with different signal characteristics should be routed separately.
- You can use the type of signal transmitted through a wire to determine which wires should be kept separate. The rule of thumb is that wiring that shares similar electrical characteristics can be bundled together.
- Keep input wiring and output wiring separate.
- It is strongly advised that you label wiring to all devices in the system when necessary.

2.7 Grounding the Switch

Grounding and wire routing help limit the effects of noise due to electromagnetic interference (EMI). Run the ground connection from the ground screw to the grounding surface prior to connecting devices.

**CAUTION!**

This product is intended to be mounted to a well-grounded mounting surface such as a metal panel.

2.8 Wiring the Redundant Power Inputs

The top two contacts and the bottom two contacts of the 4-contact terminal block connector on the Switch's top panel are used for the Switch's two AC/DC inputs. Top and front views of one of the terminal block connectors are shown here.

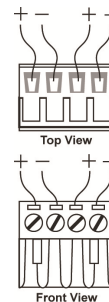

1. ➤ Insert the negative/positive AC/DC wires into the V-/V+ terminals.
2. ➤ To keep the AC/DC wires from pulling loose, use a small flat-blade screwdriver to tighten the wire-clamp screws on the front of the terminal block connector.
3. ➤ Insert the plastic terminal block connector prongs into the terminal block receptor, which is located on Switch's top panel.

**CAUTION!**

Before connecting the Switch to the AC/DC power inputs, make sure the AC/DC power source voltage is stable.

2.9 Communication Connections

The EN5-R models have 4 or 5 10/100BaseT(X) Ethernet ports, and 1 or 0 (zero) 100 BaseFX multi/single-mode (SC/ST-type connector) fiber ports. The EN8-R models have 6, 7 or 8 10/100BaseT(X) Ethernet ports, and 2, 1 or 0 (zero) 100 BaseFX multi/single-mode (SC/ST-type connector) fiber ports.

2.9.1 10/100BaseT(X) Ethernet Port Connection

The 10/100BaseT(X) ports located on the Switch's front panel are used to connect to Ethernet-enabled devices. Below we show pinouts for both MDI (NIC-type) ports and MDI-X (HUB/Switch-type) ports, and also show cable wiring diagrams for straight-through and crossover Ethernet cables.

10/100Base T(x) RJ45 Pinouts

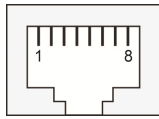

MDI Port Pinouts

Pin	Signal
1	Tx+
2	Tx-
3	Rx+
6	Rx-

MDI-X Port Pinouts

Pin	Signal
1	Rx+
2	Rx-
3	Tx+
6	Tx-

RJ45 (8-pin) to RJ45 (8-pin) Straight-Through Cable Wiring

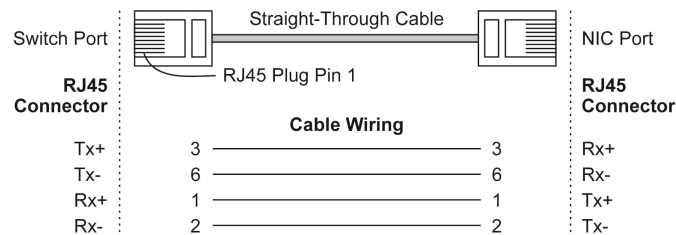

RJ45 (8-pin) to RJ45 (8-pin) Cross-Over Cable Wiring

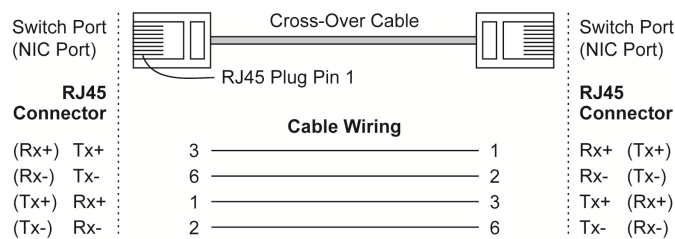

2.9.2 100BaseFX Ethernet Port Connection

The concept behind the SC/ST port and cable is quite straightforward. Suppose you are connecting devices I and II; contrary to electrical signals, optical signals do not require a circuit in order to transmit data. Consequently, one of the optical lines is used to transmit data from device I to device II, and the other optical line is used to transmit data from device II to device I, for full-duplex transmission.

Remember to connect the Tx (transmit) port of device I to the Rx (receive) port of device II, and the Rx (receive) port of device I to the Tx (transmit) port of device II. If you make your own cable, we suggest labeling the two sides of the same line with the same letter (A-to-A and B-to-B, as shown below, or A1-to-A2 and B1-to-B2).

SC-Port Pinouts

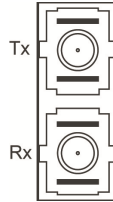

SC-Port to SC-Port Cable Wiring

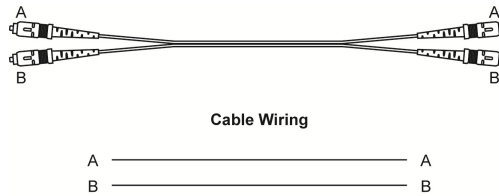

ST-Port Pinouts

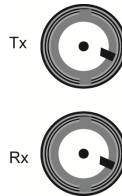

ST-Port to ST-Port Cable Wiring

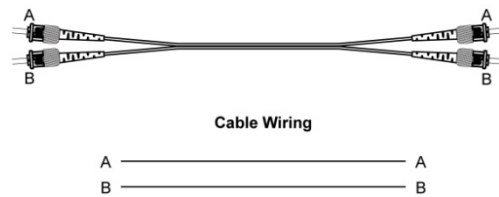

 **CAUTION!** This is a Class 1 Laser/LED product. To avoid causing serious damage to your eyes, do not stare directly into the laser beam.

2.10 Redundant Power Inputs

Both power inputs can be connected simultaneously to live DC power sources. If one power source fails, the other live source acts as a backup, and automatically supplies the EN5-R/EN8-R with power.

2.11 DIP Switch Settings

EN5-R/EN8-R DIP Switches

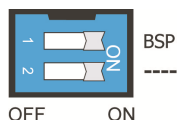

The default setting for each DIP Switch is OFF. The following table explains the effect of setting the DIP Switch to the ON position.

DIP Switch	Setting	Description
----		Serves no function (reserved for future use).
BSP	ON	Enables broadcast storm protection
	OFF	Disables broadcast storm protection



CAUTION!

To actively updated DIP switch settings, power off and then power on the Switch.

2.12 LED Indicators

The front panel of the VIPA Ethernet Switch contains several LED indicators. The function of each LED is described in the table below.

LED	Color	State	Description
P1	AMBER	On	Power is being supplied to power input P1.
		Off	Power is not being supplied to power input P1.
P2	AMBER	On	Power is being supplied to power input P2.
		Off	Power is not being supplied to power input P2.
10M	Yellow	On	TP port's 10 Mbps link is active.
		Blinking	Data is being transmitted at 10 Mbps.
		Off	TP Port's 10 Mbps link is inactive
100M	GREEN	On	TP port's 100 Mbps link is active.

LED	Color	State	Description
		Blinking	Data is being transmitted at 100 Mbps.
		Off	100Base TP Port's link is inactive.

2.13 Auto MDI/MDI-X Connection

The Auto MDI/MDI-X function allows users to connect the Switch's 10/100BaseTX ports to any kind of Ethernet device, without needing to pay attention to the type of Ethernet cable being used for the connection. This means that you can use either a straight-through cable or cross-over cable to connect the Switch to Ethernet devices.

2.14 Dual Speed Functionality and Switching

The VIPA Switch's 10/100 Mbps switched RJ45 port auto negotiates with the connected device for the fastest data transmission rate supported by both devices. All models of VIPA Switch are plug-and-play devices, so that software configuration is not required at installation, or during maintenance. The half/full duplex mode for the switched RJ45 ports is user dependent and changes (by auto-negotiation) to full or half duplex, depending on which transmission speed is supported by the attached device.

2.15 Switching, Filtering, and Forwarding

Each time a packet arrives at one of the switched ports, a decision is made to either filter or forward the packet. Packets with source and destination addresses belonging to the same port segment will be filtered, constraining those packets to one port, and relieving the rest of the network from the need to process them. A packet with destination address on another port segment will be forwarded to the appropriate port, and will not be sent to ports where it is not needed. Packets that are used in maintaining the operation of the network (such as the occasional multi-cast packet) are forwarded to all ports. The Switch operates in the store-and-forward switching mode, which eliminates bad packets and enables peak performance to be achieved when there is heavy traffic on the network.

2.16 Switching and Address Learning

The Switch has an address table that can hold up to 1024 addresses, which makes it suitable for use with large networks. The address tables are self-learning, so that as nodes are added or removed, or moved from one segment to another, the Switch automatically keeps up with new node locations. An address-aging algorithm causes the least-used addresses to be deleted in favor of newer, more frequently used addresses. To reset the address buffer, power down the unit and then power it back up.

Auto-Negotiation and Speed Sensing

All of the Switch’s RJ45 Ethernet ports independently support auto-negotiation for speeds in the 10BaseT and 100BaseTX modes, with operation according to the IEEE 802.3u standard. This means that some nodes could be operating at 10 Mbps, while at the same time, other nodes are operating at 100 Mbps. Auto-negotiation takes place when an RJ45 cable connection is made, and then each time a LINK is enabled. The Switch advertises its capability for using either 10 Mbps or 100 Mbps transmission speeds, with the device at the other end of the cable expected to advertise in a similar manner. Depending on what type of device is connected, this will result in agreement to operate at a speed of either 10 Mbps or 100 Mbps. If an Switch RJ45 Ethernet port is connected to a non-negotiating device, it will default to 10 Mbps speed and half-duplex mode, as required by the IEEE 802.3u standard.

2.17 Specifications

Technology		
Standards	IEEE 802.3 for 10BaseT, IEEE 802.3u for 100BaseT(X) and 100BaseFX, IEEE 802.3x for Flow Control	
Processing Type	Store and Forward	
Flow Control	IEEE802.3x flow control, back pressure flow control	
Interface		
RJ45 Ports	10/100BaseT(X) auto negotiation speed, F/H duplex mode, and auto MDI/MDI-X connection	
Fiber Ports	100BaseFX ports (SC/ST connector, multi/single-mode)	
LED Indicators	P1, P2 (Power), 10/100M (TP port), and 100M (Fiber port)	
DIP Switches	Master, Coupler, Turbo Ring, Reserve	
Optical Fiber		
	Multi-mode	Single-mode
Wavelength	1300 nm	1310 nm
Max. Tx	-10 dBm	0 dBm
Min. Tx	-20 dBm	-5 dBm
Rx Sensitivity	-32 dBm	-34 dBm
Link Budget	12 dB	29 dB
Typical Distance	5 km ^a , 4 km ^b	40 km ^c
Saturation	-6 dBm	-3 dBm
a. when using [50/125 μm, 800 MHz*km] cable		
b. when using [62.5/125 μm, 500 MHz*km] cable		
c. when using [9/125 μm, 3.5 PS/(nm*km)] cable		

Technology	
Power	
Input Voltage	12/24/48 VDC (9.6 to 60 VDC), 18 to 30VAC (47 to 63 Hz)
Input Current (@ 24 V)	EN5-R: Max. 0.1 A EN8-R: Max. 0.13 A
Connection	Removable 4-contact terminal block
Overload Current Protection	1.1 A
Reverse Polarity Protection	Present
Physical Characteristics	
Housing	IP30 protection, metal case
Dimensions	50 x 115 x 70 mm (EN8-R models) 30 x 115 x 70 mm (EN5-R models)
Weight	275 g (EN8-R models) 175 g (EN5-R models)
Installation	DIN-Rail, Wall Mounting (optional kit)
Environmental Limits	
Operating Temperature	0 to 60°C (32 to 140°F); -40 to 75°C (-40 to 167°F) for -T models
Storage Temperature	-40 to 85°C (-40 to 185°F)
Ambient Relative Humidity	5% to 95% (non-condensing)
Regulatory Approvals	
Safety	UL508
Hazardous Location	UL/cUL Class I, Division 2, Groups A, B, C, and D; ATEX Zone 2, Ex nA nC IIC T4 Gc
EMI	FCC Part 15, CISPR (EN 55022) class A
EMS	EN 61000-4-2 (ESD), Level 3 EN 61000-4-3 (RS), Level 3 EN 61000-4-4 (EFT), Level 3 EN 61000-4-5 (Surge), Level 3 EN 61000-4-6 (CS), Level 3 EN 61000-4-8 EN 61000-4-11
Shock	IEC 60068-2-27
Freefall	IEC 60068-2-32

Technology	
Vibration	IEC 60068-2-6
WARRANTY	5 years