



## Super Energy-Saving Medium-Voltage AC Drive FSDrive-MV1000

3 kV 200 kVA to 3700 kVA  
6 kV 400 kVA to 7500 kVA  
11 kV 660 kVA to 12000 kVA



EN

DE

ES

FR

IT



## Contents

- ▶ **Page 2**  
Introduction
- ▶ **Page 12**  
Specifications
- ▶ **Page 13**  
Dimensions
- ▶ **Page 14**  
Options
- ▶ **Page 15/16**  
Application Examples  
Model Numbers
- ▶ **Page 18**  
Standard Connections  
Diagram
- ▶ **Page 19**  
Terminal Functions
- ▶ **Page 20/21**  
Software Functions
- ▶ **Page 22**  
Drive Capacity Selection
- ▶ **Page 23**  
Global Service Network

### Completely New: World's Smallest Medium-Voltage AC Drive

#### Compact, High-Performance, Energy-Saving, and User Friendly, delivers Outstanding Value.

With the new FSDrive-MV1000 Yaskawa presents the 4th generation of medium voltage drives with power cells connected in series.

The concept of series connected power cells was first introduced back in 1996 with the VS-686HV5 drive. But time has not stopped. Driven by the incentive of creating better and better, more and more efficient, high-performance drives, Yaskawa has been continuously coming up with groundbreaking technologies, which are the foundation of today's Yaskawa products. The youngest child of those developments is the FSDrive-MV1000 series. It is the combination of long medium voltage drive experience, multi-level control technology well known from the Yaskawa G7 drive series, bundled with the ease of use of the 1000 series low voltage drives.

An ultra compact design, outstanding performance, remarkable energy saving capabilities, and easy operation and handling make the FSDrive-MV1000 the first choice for cost effective medium voltage solutions.

#### Compact Design

- ▶ Significant downsizing and a draw-out design help this power cell facilitate transportation, installation, and maintenance.

Long-life and highly reliable parts have been stringently selected, and the circuit design simplified for compactness. Drives have evolved into more reliable and space saving FSDrive-MV1000 drives

#### High Performance

- ▶ Offering better performance, functionality, and reliability in low-and medium-voltage drives, and enabling stable continuous operation.

Equipped with functions unaffected by fluctuations in power supply and load. Input and output are both sinusoidal waves. FSDrive-MV1000 can be easily introduced into either new or existing facilities without any qualms.

### Energy Saving

- ▶ Promotes energy saving with highly efficient operation.

FSDrive-MV1000 realizes the highest levels of efficiency and power factor in the industry. Significant energy saving effects can be achieved.

### User Friendly

- ▶ Operation, adjustment, maintenance, and management are very easy, as with Yaskawa low-voltage drives.

FSDrive-MV1000 focuses on ease of use. Adopting the same user interface as Yaskawa low-voltage drives has made it easier to check the operating status and manage parameters.

A combination of our technical capabilities and our reliability.

#### Low-voltage drive

**G7** 7th generation low-voltage drive  
(The world's first general-purpose drive employing three-level control)

#### 1000series

(J1000/V1000/A1000)



#### Medium-voltage drive

### VS-686HV5

Medium-voltage drive with multiple power cells connected in series (first commercial product in Japan)

### VS-686HV5S

### VS-686HV5SD

### FSDrive-MV1S

# Significant Downsizing and a Draw-out Design facilitates Transportation, Installation and Maintenance.

## Compact Design

### 6-kV class Example Configuration of FSDrive-MV1000

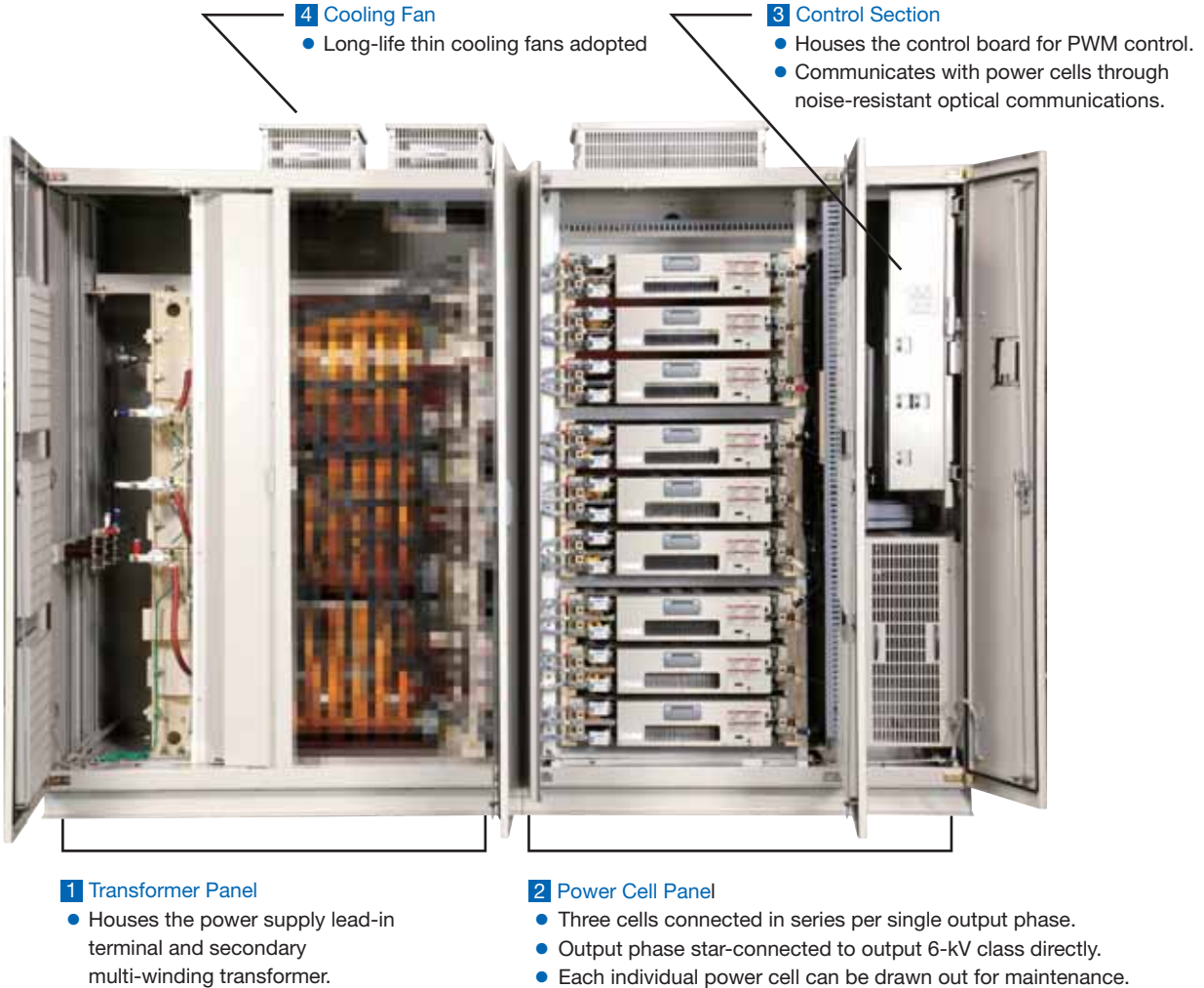

## Circuit Configuration

6-kV class

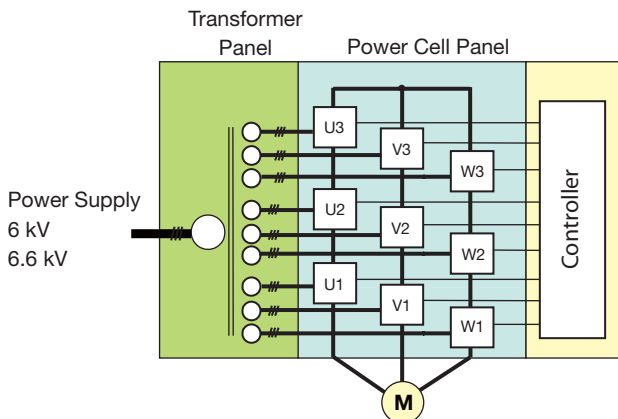

• Configuration of One Power Cell

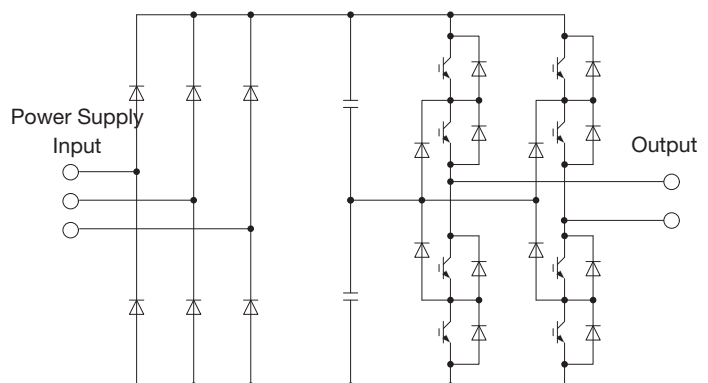

# Optimised Component Selection and Arrangement Reduces Volume occupied by up to 60 %!

## Minimal Height and Small Footprint

The compact design realized by developing thin power cells with three-level single phase output, and adopting a simple circuit configuration, a draw-out control panel and thin cooling fans, has resulted in a significant volume reduction of 30 to 60% when compared to the conventional Yaskawa product. The unit can even fit in a standard container for transportation\*.

\*Restrictions might apply. Please contact Yaskawa for details.

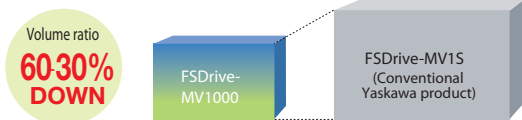

Everything has been done to achieve a small footprint, especially for 3-kV class drives, with the transformers located in the bottom of the panel and the power cells and controller at the top.

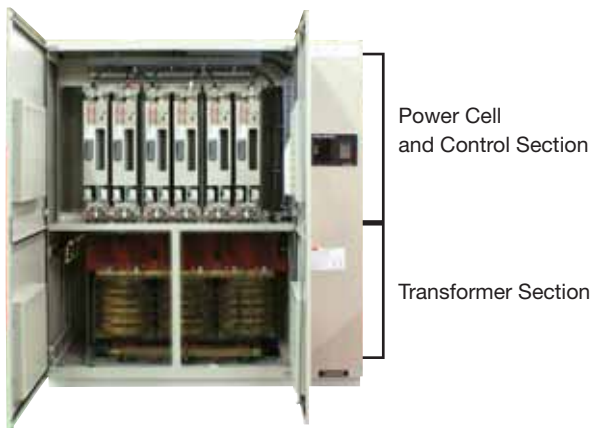

## Maintenance of Individual Power Cells

Power cells can be replaced and maintained individually. The construction designed for single-action mounting and removal reduces the replacement time and facilitates maintenance operations.



3-kV class

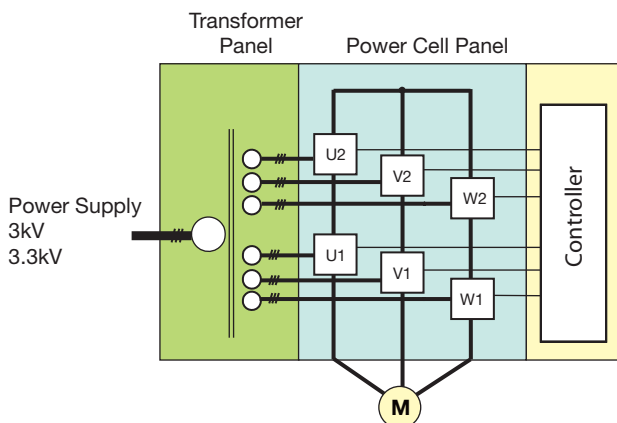

11-kV class

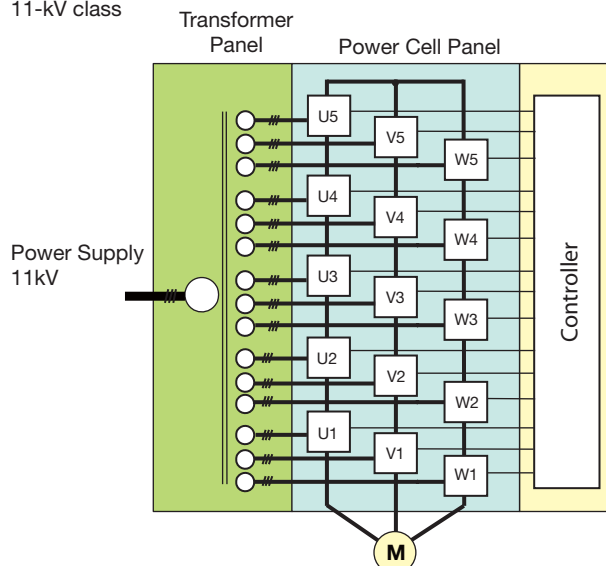



Offering better Performance, Functionality, and Reliability in low- and medium-voltage Drives, and enabling stable continuous Operation.

## High Performance

Employs Open Loop Vector Control.  
Highly Resistant to Fluctuations in Power Supply and Load!

### High-level Control

Open Loop Vector control enables smooth acceleration from a low-speed range without using a speed detector. Operation is stable, unaffected by fluctuations in load. The high performance vector control drives synchronous motors as well as induction motors.

#### ▶ Starting Characteristics

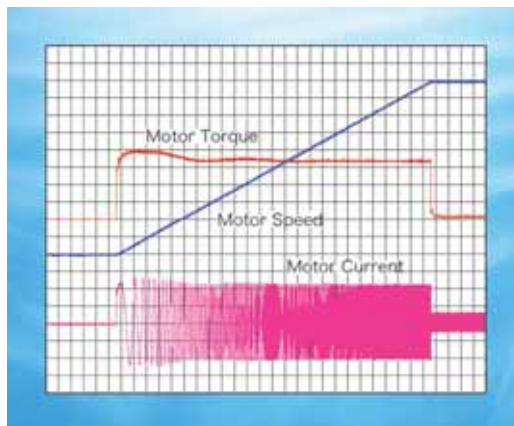

### Running Multiple Motors

The capability to run multiple induction motors in parallel with a single drive can reduce the size of the system as a whole.



Note: When running multiple motor operations, a protective device is required on each motor.

### Controlled and Secure Operation at Momentary Power Loss

FSDrive-MV1000 continues to operate for a number of cycles\*1 when a momentary power loss occurs, and re-accelerates to the reference speed immediately after the power is restored to ensure a smooth system start-up.

\*1: The retention time varies depending on the types of load and operation status.

#### ▶ Speed Search Function

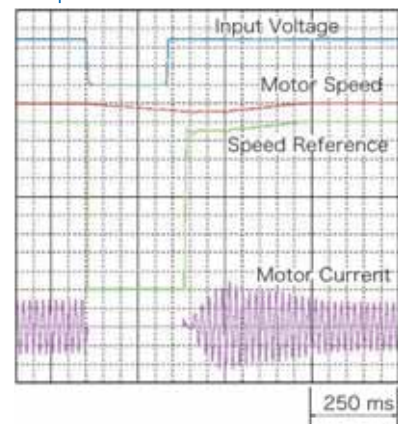

#### ▶ KEB Function \*2

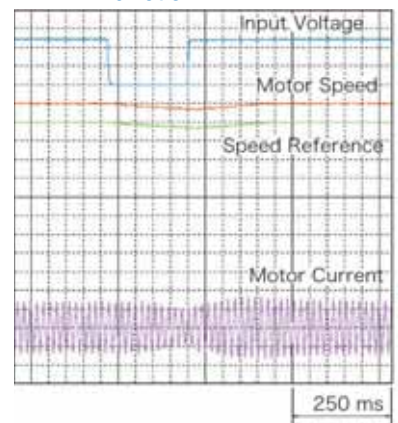

\*2: KEB (Kinetic Energy Back-up) Function: Function to continue operation without baseblocking during a momentary power loss.

## Incorporates Yaskawa's Smart Harmonics Technology and PWM Control with Multiple Outputs Connected in Series. Sinusoidal Input and Output Waves Ensure Easy Introduction at Facilities!

### Minimized Harmonics Comply with Guidelines

Yaskawa's original smart harmonics technology incorporated in FSDrive-MV1000 drastically cuts input harmonics. The resulting input waveform is sinusoidal, making it possible to clear the harmonics control guideline specified by IEEE519-1992, as an individual drive. This means that no harmonics filter or active filter is necessary.

#### Measured Harmonics in Input Current

(For 3.3 kV, 630 kW, 60 Hz, full-load contract demand of 630 kW)

	5th	7th	11th	13th	17th	19th	23rd	25th	29th	31st
IEEE 519	4.00	4.00	2.00	2.00	1.50	1.50	0.60	0.60	0.60	0.60
Guideline*	4.00	2.80	1.80	1.50	1.10	1.00	0.90	0.80	0.80	0.80
FS Drive-MV1000 Measured Value	1.00	0.60	1.40	0.90	0.10	0.20	0.40	0.20	0.30	0.10

\* Guideline of the Ministry of Economy, Trade and Industry (Unit: %)

#### Input Waveform

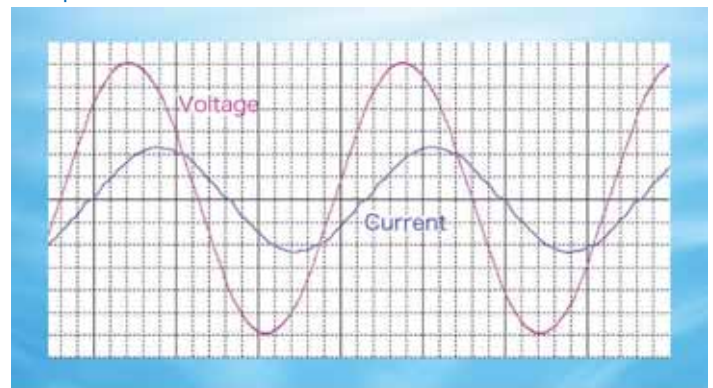

#### Output Waveform

Line-to-Line Voltage (for 6-kV Class Drives)

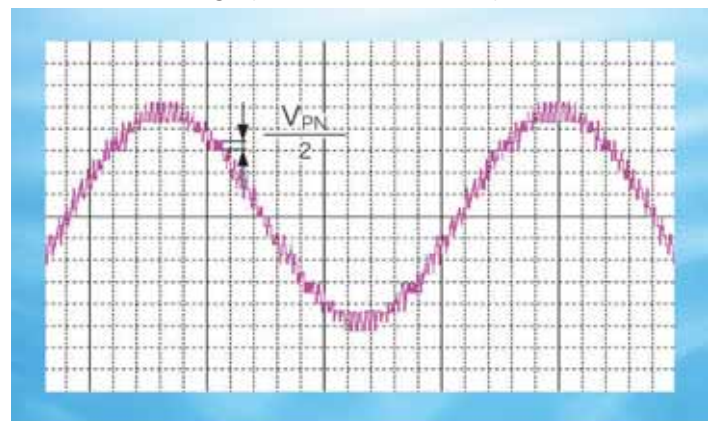

Phase Voltage (For Single Power Cell)

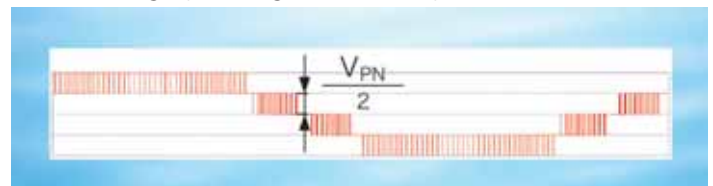

Note:  $V_{PN}$ : DC bus voltage for a single power cell

### Easily Applicable to Existing Motors

PWM control with multiple power cells connected in series outputs sinusoidal wave voltage. This has the following benefits:

- Free from oscillation surge voltage affecting the motor
- Low torque ripple, easing the load
- Noise as low as commercial power supply operation

These benefits make it possible to use the existing motors and wiring cables without adding filters or other modifications.



The simple configuration for running standard high voltage motors directly realizes highly efficient operation with minimal loss due to input/output voltage transformers.

## Promotes Energy Saving with highly efficient Operation.

### Energy Saving

## World's Highest Standard of Performance Reduces Power Wastage!

### High Efficiency and High Power Factor

Since FSDrive-MV1000 is a direct medium-voltage drive that does not need an output transformer, it can maintain a power conversion efficiency of approximately 97% over a wide speed range and secure a power supply factor of 0.95 (at rated load), avoiding energy wastage.

#### ► Power Conversion Efficiency Ratio

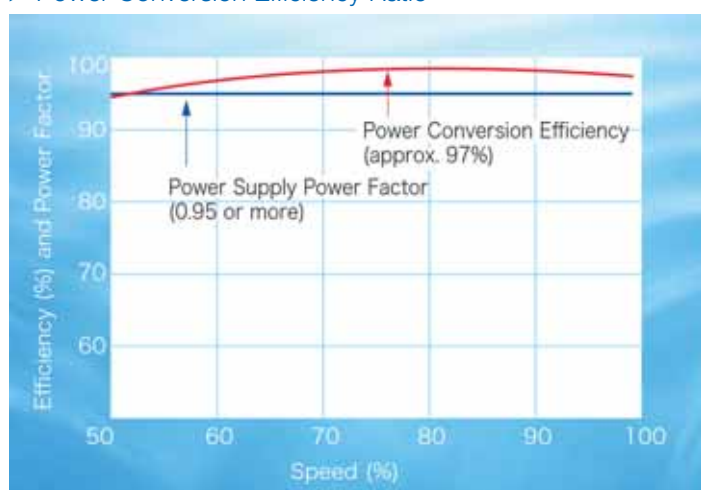

### Energy Saving by Speed Control

The shaft power of wind and hydraulic machines such as fans, blowers, and pumps is proportional to the cube of the rotational speed.

Since drives maintain high efficiency even at low speed, a significant energy saving effect can be expected by using drives for wind and hydraulic machines and operating them at lower speeds.

#### ► Power Consumption Characteristic Curve

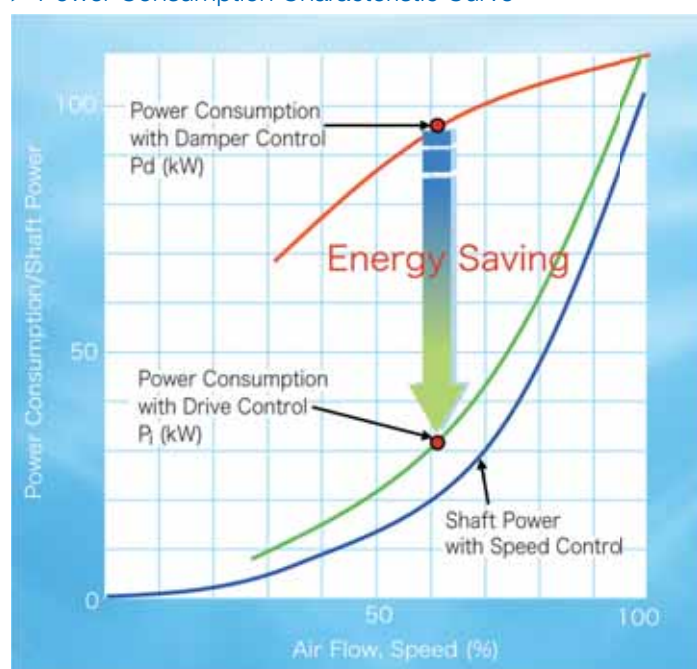



Operation, Adjustment, Maintenance, and Management are very easy, as with Yaskawa low-voltage Drives.

User Friendly

## Employs the Same User Interfaces as Yaskawa's 1000 Series Low-voltage Drives

### Easy-to-use User Interfaces

A Digital Operator with an easy-to-view LCD display (the same as used on Yaskawa's 1000 series low-voltage drives) is provided on the front panel as standard, making it easy to operate and set the drive.

The engineering tool DriveWizard Plus MV enables consolidated management of the parameters for each drive and makes for easy adjustment and maintenance.



▶ Refer to pages 10 and 11 for details.

### Compatible with World's Major Field Network Protocols

The RS-485 communication function (MEMOBUS/Modbus protocol) is installed as standard. By adding an optional communication card, the major field network protocols can be supported. Achieve centralized control of production equipment and fewer connecting cables by connecting the drive to host computer or PLC.

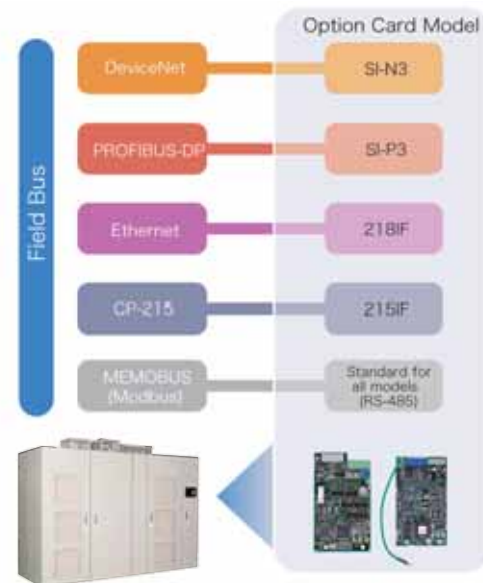

FSDrive-MV1000 Option Card

\*: Yaskawa's dedicated communication protocol

Note: Product names are trademarks or registered trademarks of the companies concerned.

### USB Copy Unit (Model: JVOP-181)

Enables the copying and transfer of parameters between drives using simple operations. This unit can also be used as a conversion connector between the communication port (RJ-45) of an drive and a USB port of a PC.

Note: No USB cable is needed to copy parameters to other drives.

#### ▶ Connection

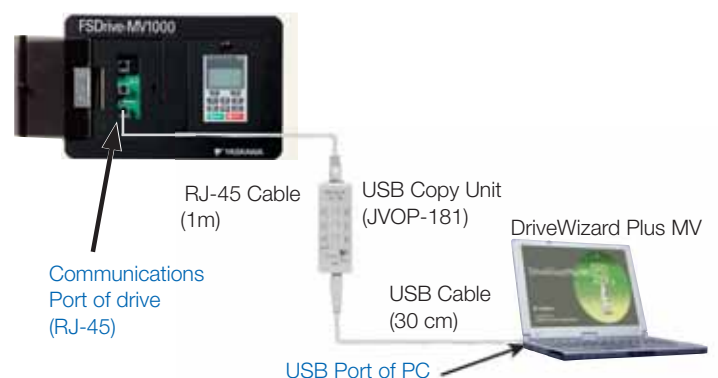

# A Digital Operator is installed as Standard to Facilitate Configuration, Operation, and Monitoring.

## User Friendly

### Full Text LCD Operator

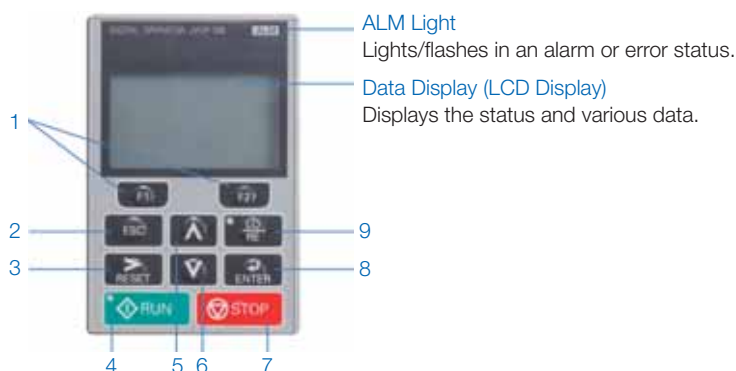

#### Key Names and Functions

No.	Key	Name	Function
1	F1 F2	Function Key (F1/F2)	The functions assigned to F1 and F2 vary depending on the currently displayed menu. The name of each function appears in the lower half of the LCD display window.
2	ESC	ESC KEY	<ul style="list-style-type: none"> <li>Returns to the previous display.</li> <li>Moves the cursor one digit to the left when setting parameter numbers.</li> <li>Pressing and holding this button returns to the Frequency Reference display.</li> </ul>
3	RESET	RESET Key	<ul style="list-style-type: none"> <li>Moves the cursor one digit to the right when setting parameter values, etc.</li> <li>Resets the drive to clear a fault situation.</li> </ul>
4	RUN	RUN Key	Starts drive operation.
	RUN LED	RUN LED	Lit or flashing while the drive is running.
5	Up Arrow	Up Arrow Key	<ul style="list-style-type: none"> <li>Scrolls up to display the next item.</li> <li>Increments the parameter number or the setting value.</li> </ul>
6	Down Arrow	Down Arrow Key	<ul style="list-style-type: none"> <li>Scrolls down to display the previous item.</li> <li>Decrements the parameter number or the setting value.</li> </ul>
7	STOP	STOP Key	Stops drive operation. Note: The drive can be stopped in an emergency stop status by pressing <b>STOP</b> when danger is detected even if the drive is operating in the REMOTE mode in accordance with Run commands other than from the digital operator. To disable emergency stop operation using <b>STOP</b> , set parameter o2-02 (STOP key function selection) to 0 (disabled).
8	ENTER	ENTER Key	<ul style="list-style-type: none"> <li>Enters the selected operation mode, parameter number and setting value.</li> <li>Selects a menu item to move between displays.</li> </ul>
9	LO/RE	LO/RE Selection Key	Switches the control of the drive between the digital operator (LOCAL mode) and an external source (REMOTE mode) for the Run command and frequency reference. Note: When there is a danger that the operation of the drive may be disrupted by erroneously switching the operation mode from REMOTE to LOCAL, disable <b>LO/RE</b> by setting parameter o2-01 (LO/RE selection key function selection) to 0 (disabled).
	LO/RE LED	LO/RE LED	Lit while the operator is selected to run the drive (LOCAL mode).

#### Drive operation status and relevant RUN LED indications

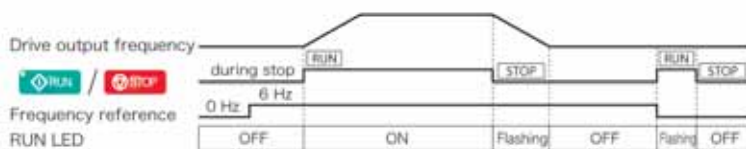

# „DriveWizard Plus MV“ supports Adjustment and Maintenance Tasks.

## Providing Support with a Variety of Functions

DriveWizard Plus MV enables consolidated management of the parameters for each drive on your PC. A variety of functions including monitoring, parameter editing, pattern operation, and oscilloscope functions, facilitates adjustment and maintenance of the drives. In addition, the extensive trace and event log functions enable implementation of preventive maintenance and a quick response in case of trouble.



### System Requirements

<b>PC</b>	IBM PC compatible computers Note: Operation on NEC PC9821 series computers is not guaranteed.
<b>CPU</b>	Pentium 1GHz or higher (1.6 GHz recommended)
<b>Main Memory</b>	1 GB or greater
<b>Available Hard Disk Space</b>	In the standard setup configuration: • 100 MB or greater (400 MB or greater recommended at time of installation)
<b>Display Resolution</b>	XGA monitor (1024 × 768 or higher, use "Small Fonts".)
<b>Number of Colors</b>	65535 colors (16 bits) or greater
<b>OS</b>	English or Japanese operating system (32-bit OS only) • Windows 2000 Service Pack 1 or later • Windows XP • Windows Vista • Windows 7
<b>Others</b>	More than one RS-232, RS-485 or USB port CD-ROM drive (only for installation) Adobe Reader 6.0 or later Note: Adobe Reader is required to display the help information.

Note: Pentium is a registered trademark of Intel Corporation.

Windows 2000/XP/Vista/7 are registered trademarks of Microsoft Corporation.

### ▶ Pattern Operation

Runs the drive automatically in the preset patterns.



### ▶ Parameter Edit

Displays and edits drive parameters.



### ▶ Auto-tuning

Automatically adjusts the motor-related parameters.



### ▶ Troubleshooting

Checks the faults that have occurred on the drive. Causes are quickly investigated by tracing fault status and the corrective actions are displayed.



### ▶ Oscilloscope

Displays the monitor data in real time while the is running.

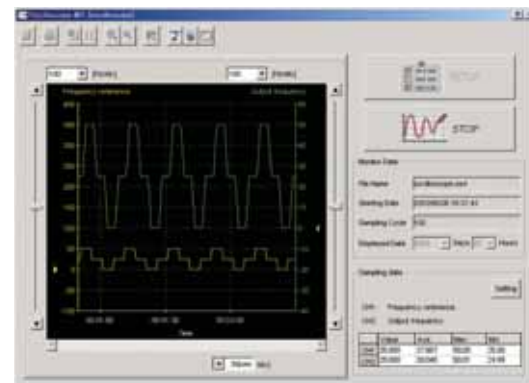

# Specifications

## Model-Specific Specifications

Model	CIMR-MV2A □□□□	035	050	070	100	140	200	260	330	400	520	650	
Nominal Capacity	3.0kV/3.3 kV Output	kVA	200	285	400	570	800	1150	1500	1900	2300	3000	3700
	Max. Applicable Motor Capacity	kW	132	200	315	450	630	900	1250	1500	1800	2500	3000
Output Rating	Rated Output Current	A	35	50	70	100	140	200	260	330	400	520	650
	Rated Output Voltage	V	Three -phase, 3000 V or 3300 V (sinusoidal wave, proportional to input voltage)										
Power Supply	Main Circuit		Three -phase, 3000 V (50 Hz ± 5 Hz) or 3300 V (50/60 Hz ± 5 Hz) —20% to +10%										
	Control Circuit		Single-phase, 200/220 V 50/60 Hz ± 10% / CE Version: 230V ± 10%										
Model	CIMR-MV2C □□□□	035	050	070	100	140	200	260	330	400	520	650	
Nominal Capacity	6.0 kV/6.6 kV Output	kVA	400	570	800	1150	1600	2300	3000	3800	4600	6000	7500
	Max. Applicable Motor Capacity	kW	250	400	630	900	1250	1800	2500	3000	3600	5000	6000
Output Rating	Rated Output Current	A	35	50	70	100	140	200	260	330	400	520	650
	Rated Output Voltage	V	Three-phase, 6000 V or 6600 V (sinusoidal wave, proportional to input voltage)										
Power Supply	Main Circuit		Three-phase, 6000 V (50 Hz ± 5 Hz) or 6600 V (50/60 Hz ± 5 Hz) —20% to +10%										
	Control Circuit		Single-phase, 200/220 V 50/60 Hz ± 10% / CE Version: 230V ± 10%										
Model	CIMR-MV2A □□□□	035	050	70	100	140	200	260	330	400	520	650	
Nominal Capacity	10 kV/10.5 kV/11 kV Output	kVA	660	950	1300	1900	2650	3800	5000	6200	7600	9900	12000
	Max. Applicable Motor Capacity	kW	530	760	1070	1520	2130	3050	3960	5030	6100	7930	9910
Output Rating	Rated Output Current	A	35	50	70	100	140	200	260	330	400	520	650
	Rated Output Voltage	V	Three-phase, 10000 V, 10500 V or 11000 V (sinusoidal wave, proportional to input voltage)										
Power Supply	Main Circuit		Three-phase, 10000 V, 10500 V or 11000 V (50/60 Hz ± 5 Hz) —20% to +10%										
	Control Circuit		Single-phase, 200/220 V 50/60 Hz ± 10% / CE Version: 230V ± 10%										

## Common Specifications

Efficiency	Approx. 97% (At rated motor speed, 100% load)	
Power Factor	Min. 0.95 (At motor rated speed, 100% load)	
Cooling Method	Forced air-cooling by fan (with failure detection)	
Specifications	Control Method	Open-loop vector control, Closed loop vector control, V/f control (for multiple motor operation), Closed loop vector control for SM (option)
	Main Circuit	Voltage-type PWM control with multiple outputs connected in series (power cell: 3-level output)
	Freq. Control Range	0.01 to 120 Hz
	Freq. Control Accuracy	± 0.5%
	Analog Input Resolution	0.03 Hz
	Accel/Decel Time	0.1 to 6000 s
	Torque Accuracy *1	± 5% (open-loop vector control), ± 3% (closed loop vector control)
	Overload Tolerance	Continuous rated current 100%, overload tolerance 110% for 1 minute and 120% for 15 seconds
	Momentary Power Loss Compensation Time *2	Max. 2 seconds
	Main Control Functions	Torque control, Droop control, Speed/torque control switch, Momentary power loss compensation, Speed search, Over torque detection, Torque limit, 17-s tep speed (max.), Accel/decel time switch, S-curve accel/decel, 3-wire sequence, Auto-tuning (rotational, stationary), Dwell, Cooling fan on/ off, Slip compensation, Torque compensation, Frequency jump, Upper/ lower limits for frequency reference, DC injection braking at start and stop, High slip braking, PID control (with sleep function), Energy saving control, MEMOBUS communication (RS-485, max. 115.2 kbps), Fault retry
Protective Functions	Overcurrent, Overvoltage, Undervoltage, Output ground fault, Output open-phase, Overload, Cooling-fan error, Transformer overheat, Motor overheat, etc.	
PLC Functions	Expansion PLC board (option)	
Standard Communication Functions	RS-232: Digital operator RS-485: MEMOBUS (Modbus) USB : DriveWizard Plus MV	
Communications (optional) *3	Any one of PROFIBUS-DP, DeviceNet, Ethernet, or CP-215 can be installed.	
Input Transformer	Class H dry type, -5%/N/ +5% tap, secondary multi-phase winding	
Temperature Protection	Power cells: protected by thermistor for temperature Transformer: protected by thermometer PT100 Ω	
Maintainability/ Environmental Specifications	Control Panel	Status display, Fault display, Parameter setting, Parameter reference
	Main Circuit	Power cell construction
	Protection Design	IP40 (simplified dustproof type)
	Ambient Temperature, Relative Humidity	-5°C to +40°C, 85% RH max. (no condensing)
	Storage Temperature	-20°C to +60°C (for very short term when handling)
Atmosphere	General environmental conditions, free from dust and corrosive gases Altitude: Max. 2000 m	
Panel Specifications	Painting	5Y7/1 semi-gloss both for inner and outer faces
	Form	Made of enclosing steel sheets, vertical standalone type, front maintenance type
Applicable Standards	JIS, JEM, JEC, CE for 6kV. Please contact YASKAWA for CE on 3kV and 10 kV units.	

\*1 Adjustments, e.g. to parameters, are required after auto-tuning \*2 When the momentary power loss compensation function is used, an uninterruptible power supply unit for the control power supply is needed (this is an option). \*3 To implement the communication function, an option card needs to be installed. For Ethernet or CP-215 communication, an optional expansion PLC board is required. Note: Contact Yaskawa regarding 2-kV/4-kV power supply for the main circuit.

## Dimensions and Model Numbers

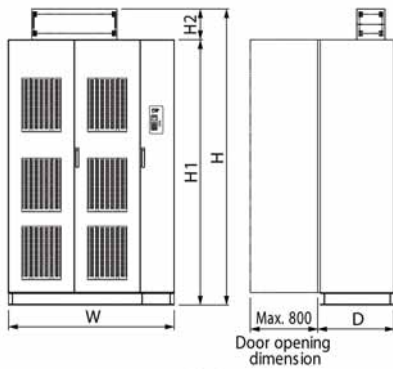

Fig.1

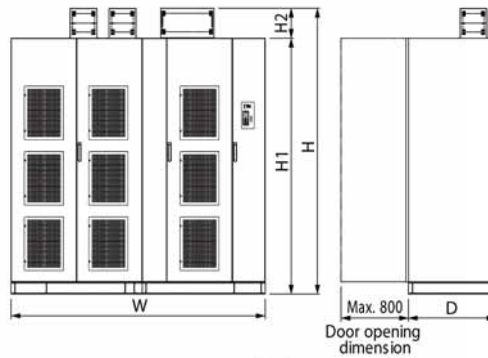

Fig.2

Power Supply	Model CIMR-MV2A	Capacity kVA	Current A	Dimensions *2 mm					Approx. Mass *2 kg	Figure			
				Width	Depth	Height	Height	Height					
				W	D	H	H1	H2					
3kV	C□CA035	200	35	1950	1000	2550	2150	400	2100	Fig.1			
	C□CA050	285	50						2200				
	C□CA070	400	70						2400				
	C□CA100	570	100						2600				
	C□CA140	800	140						2800				
	C□CA200	1150	200	3000*1	1100	2550	2150	400	4100		Fig.2		
	C□CA260	1500	260	3500*1	1200	2550	2150	400	5500				
	C□CA330	1900	330	4100*1	1600	2550	2150	400	7000				
	C□CA400	2300	400	4100*1	1600	2550	2150	400	7400				
	C□CA520	3000	520	5300*1	1600	2800	2400	400	8800				
C□CA650	3700	650	5600*1	1600	2800	2400	400	9900					
6kV	F□FA035	400	35	3100*1	1100	2550	2150	400	3600	Fig.2			
	F□FA050	570	50						4000				
	F□FA070	800	70						4300				
	F□FA100	1150	100						4700				
	F□FA140	1600	140						5000				
	F□FA200	2300	200	4500*1	1300	2550	2150	400	7400				
	F□FA260	3000	260	5550*1	1300	2550	2150	400	8800				
	F□FA330	3800	330	6300*1	1600	2800	2400	400	10500				
	F□FA400	4600	400						11300				
	F□FA520	6000	520						7100*1		1600	2900	2400
F□FA650	7500	650	7300*1						1600	2900	2400	500	15200
11kV	H□HA035	660	35	5100*1	1400	2700	2400	300	7600	Fig.2			
	H□HA050	950	50						7800				
	H□HA070	1300	70						8000				
	H□HA100	1900	100						8200				
	H□HA140	2650	140						8400				
	H□HA200	3800	200	6900*1	1500	2700	2400	300	10500				
	H□HA260	5000	260	7300*1	1600	2800	2400	400	13200				
	H□HA330	6200	330	8800*1	1700	2800	2400	400	16000				
	H□HA400	7600	400						17000				
	H□HA520	9900	520						10200*1		1800	2900	2400
H□HA650	12000	650	25000										

\*1: Block construction

\*2: The dimensions and masses may be changed.



# Options

Type	Name	Function	Manual No.
Built-in Type (connected to terminal, must be ordered together with ineste)	Speed (Frequency) Reference Card	Analog Input AI-A3 Enables high-precision and high-resolution analog speed reference setting. • Input signal level: -10 to +10 Vdc (20 k Ω) 4 to 20 mA (500 Ω) • Input channels: 3 channels (DIP switch for input voltage/input current selection) • Input resolution: Input voltage 13 bit signed (1/8192) Input current 1/6554	TOBPC73060038
		Digital Input DI-A3 Enables 16-bit digital speed reference setting. • Input signal: 16 bit binary, 4 digit BCD + sign signal + set signal • Input voltage: +24 V (isolated) • Input current: 8 mA User-set: 8 bit, 12 bit, 16 bit	TOBPC73060039
	Communications Card *1	DeviceNet Interface SI-N3 Used for running or stopping the drive, setting or referencing parameters, and monitoring output frequency, output current, or similar items through DeviceNet communication with the host controller.	TOBPC73060043 SIJPC73060043
		PROFIBUS-DP Interface SI-P3 Used for running or stopping the drive, setting or referencing parameters, and monitoring output frequency, output current, or similar items through PROFIBUS-DP communication with the host controller.	TOBPC73060042 SIJPC73060042
		CP-215 Interface 215IF Used for running or stopping the drive, setting or viewing parameters, and monitoring output frequency, output current, etc. through CP-215 communication with the host controller. CP-215 communication system is a high-speed, real-time, N: N network with shared memory and handling both cyclic and message transmissions. An expansion PLC board is needed to use the CP-215.	Under development
		Ethernet (CP-218) Interface 218IF Used for running or stopping the drive, setting or viewing parameters, and monitoring output frequency, output current, etc. through CP-218 communication with the host controller. CP-218 communication system is a type of Ethernet that supports communication with the MEMOBUS protocol, non-protocol, or MELSEC protocol. An expansion PLC board is needed to use the CP-218.	Under development
	Monitor Card	Analog Monitor AO-A3 Outputs analog signal for monitoring drive output state (output freq., output current etc.). • Output resolution: 11 bit signed (1/2048) • Output voltage: -10 to +10 Vdc (non-isolated) • Terminals: 2 analog outputs	TOBPC73060040
		Digital Output DO-A3 Outputs isolated type digital signal for monitoring drive run state (alarm signal, zero speed detection, etc.) • Terminals: 6 photocoupler outputs (48 V, 50 mA or less) 2 relay contact outputs (250 Vac, 1 A or less 30 Vdc, 1 A or less)	TOBPC73060041
	PG Speed Controller Card *2	Complementary Type PG Interface PG-B3 For control modes requiring a PG encoder for motor feedback. • Phase A, B, and Z pulse (3-phase) inputs (complementary type) • Max. input frequency: 50 kHz • Pulse monitor output: Open collector, +24 V, max. current 30 mA • Power supply output for PG: +12 V, max. current 200 mA	TOBPC73060036
		Line Driver PG Interface PG-X3 For control modes requiring a PG encoder for motor feedback. • Phase A, B, and Z pulse (differential pulse) inputs (RS-422) • Max. input frequency: 300 kHz • Pulse monitor output: RS-422 • Power supply output for PG: +5 V or +12 V, max. current 200 mA	TOBPC73060037
PLC Function	Expansion PLC Board BC-620 Supplements PLC functions required to customize the drive. • Program memory capacity: Equivalent to 8,000 steps • Execution speed: 1,000 steps/1 ms • Language: Ladder language, textual language	Under development	
Panel Housed Type	Momentary Power Loss Compensation Uninterruptible Power Supply Unit	UPS is installed inside the panel and backs up a control power supply when momentary power losses occur. This option is required to implement measures against momentary power loss (for the speed search function or KEB function).	-
	Backup Cooling Fan	Automatically enables continued operation of the drive in case of one of the cooling fans fails to operate. (N + 1 backup system)	Under development
	Panel Door Open Interlock	Detects opening of the panel door by adding a limit switch. Medium-voltage power shutdown command is output on detecting opening.	-
Separate Installation Type	USB Copy Unit JVOP-181	Enables the copying and transfer of parameters between drives using (one-touch) simple operations. This unit can also be used as a conversion connector between the communication port (RJ-45) of an drive and a USB port of a PC running DriveWizard Plus MV. This option comprises a copy unit with USB interface, an RJ-45 cable and a USB cable.	KAEP71061622
	Lifter for Replacing Power Cells	Facilitates power cell replacement.	-
	Inrush Current Suppression Circuit	Suppresses the inrush current on turning the drive power on by adding a suppression circuit.	Under development

\*1: Only one optional communication card can be selected.

\*2: To apply PG control, the PG speed control card must be selected.

## Model Numbers

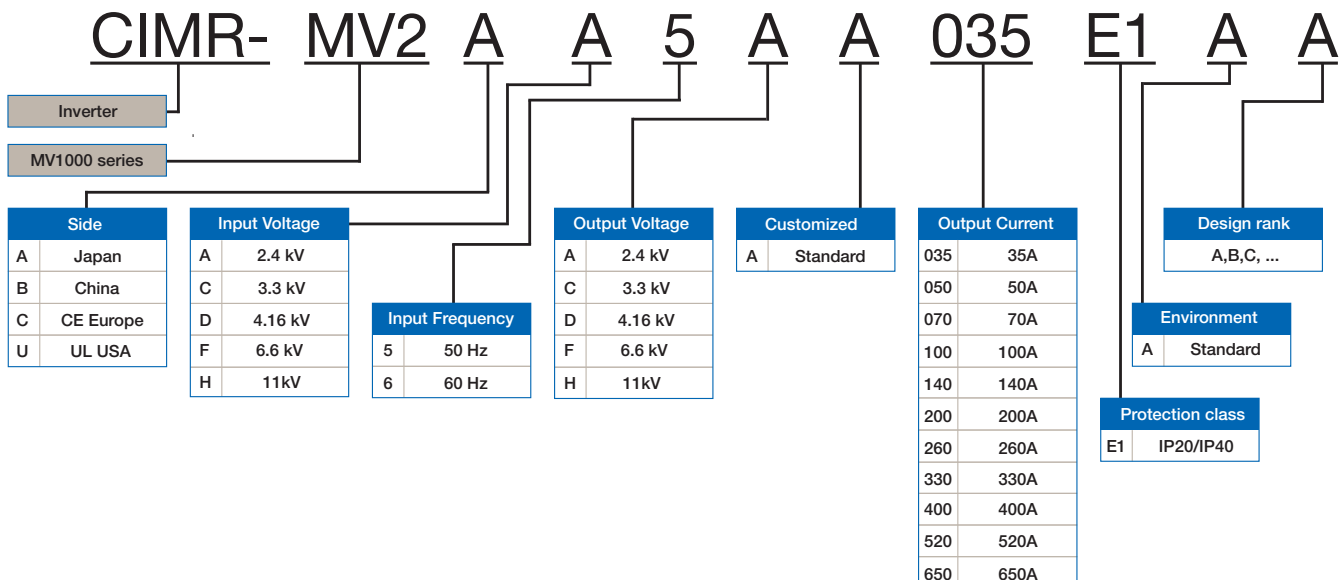

## Application Examples Fans, Blowers, Pump Equipment (Variable Torque Load)

### Advantage

#### 1. Energy-saving operation

Switching operation from conventional damper (valve) control using a commercial power supply to frequency control with FSDrive-MV1000 saves a large amount of energy. Even bigger energy savings are possible with machines with standby operation (under normal duty conditions).

#### 2. Stable operation

The speed can be retrieved quickly by speed search function in response to momentary power losses.\* KEB function allows operation to continue without base-blocking even when momentary power losses occur. When priority is given to continuing operation, fault restart function enables FSDrive-MV1000 to continue running even if an unexpected error is detected.

\*: A UPS unit is required in addition to supply control power.

#### 3. Achievement of ideal operation patterns

Because the airflow (flow rate) is controlled directly by the drive output frequency, with none of the pressure loss by dampers (valves), the ideal operation pattern can be achieved easily.

The machine can be started and stopped frequently.

With speed search function, operation can be smoothly restarted even when fans are coasting.

Minimum frequency setting function prevents pumps from failing to supply, meaning that stable supply can be maintained.

#### 4. Extended machine life

The machine runs at low speed during no-load operation, helping to prolong its life.

Machine life can be further extended by operation methods that minimized impact on the machine by using FSDrive-MV1000 to attain soft starting and soft stopping.

#### 5. Reduced power supply capacity

With FSDrive-MV1000 the accel/decel time can be set as required, and the starting current can be cut substantially. This means that power supply capacity can be reduced.

# General Industrial Machinery (Constant Torque Load)

## Application Examples



## Advantages

Vector control makes it simple to operate even constant torque loads like extruders, conveyors, rotary kilns, banbury mixers and machine tools.

### 1. Improved response and operating efficiency

- High starting torque required for operation is provided.
- Vector control improves response against load fluctuations, enabling stable operation.
- Starting current can be kept lower than with direct-on-line, enabling frequent stopping and starting and efficient operation.

### 2. Improved speed control accuracy

- High-accuracy speed control allows application to machines that demand accuracy, which was difficult with variable speed systems using conventional rotor resistance control.

### 3. Energy-saving effects

- Using frequency control instead of rotor resistance control of conventional fluid-coupling and wound rotor motors eliminates loss in low-speed operations and saves energy.

### 4. Better maintainability

- Using a squirrel-cage motor with drive control enables better maintainability than conventional wound rotor motors with rotor resistance control.
- Using drives instead of fluid couplings simplifies the drive system and considerably reduces mechanical maintenance.

## Others



Example 1: Commercial power backup system

Example 2: Drive backup system

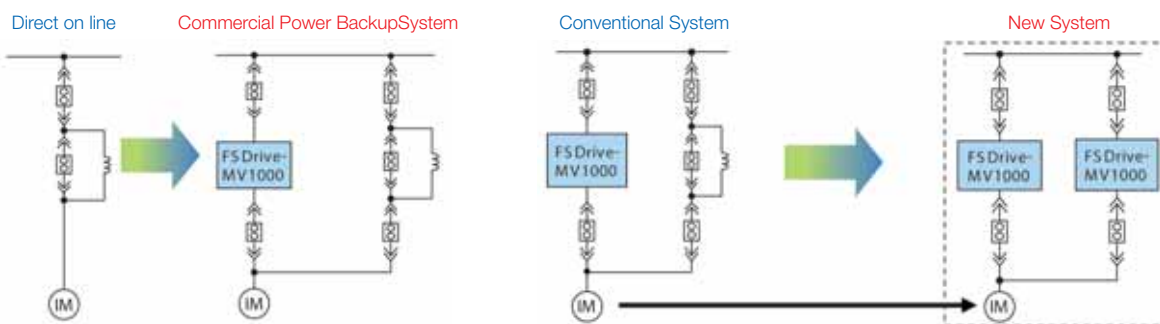

Introduce a drive with existing equipment.

- The existing equipment (breakers, cables, etc.) for commercial power operation can be reused as a backup circuit.

For machine with large inertia, the total cost is reduced with drive backup

- The motor is not started by commercial power, so the size of the motor frame is smaller, enabling cost reductions and space savings.
- The system can be run by the backup drive in an emergency. (When using commercial power operation for an application of large inertia a substantial motor frame is needed and this increases the cost.)

Example 3: Achieving variable speed control of an existing wound rotor motor

System of existing wound rotor motor + medium-voltage drive

Drives can be put to use with wound rotor motors too.

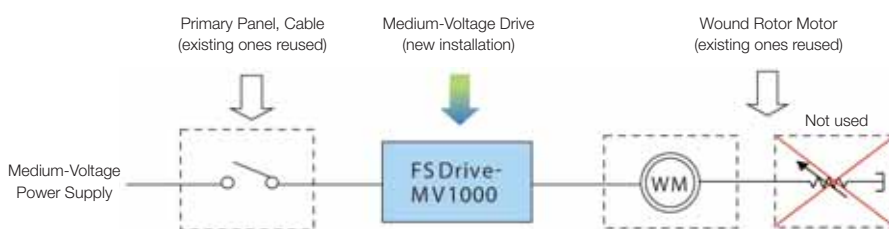

- Achieves energy savings.
- The existing motor and cables are reused.
- Maintenance of motor brushes and resistors is not necessary.

Short the secondary side of the existing wound rotor motor.

Example 4: Synchronization switching system for synchronous motors

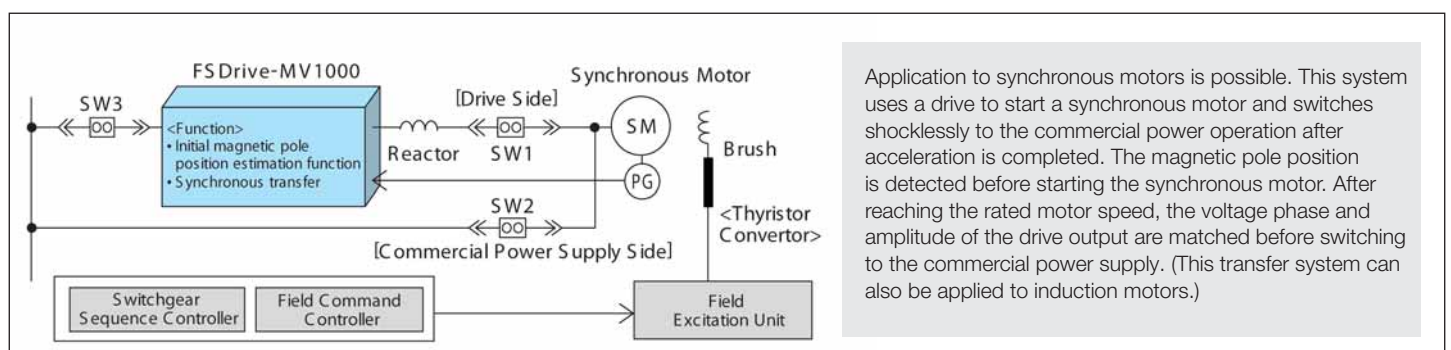

Application to synchronous motors is possible. This system uses a drive to start a synchronous motor and switches shocklessly to the commercial power operation after acceleration is completed. The magnetic pole position is detected before starting the synchronous motor. After reaching the rated motor speed, the voltage phase and amplitude of the drive output are matched before switching to the commercial power supply. (This transfer system can also be applied to induction motors.)

# Standard Connections Diagram

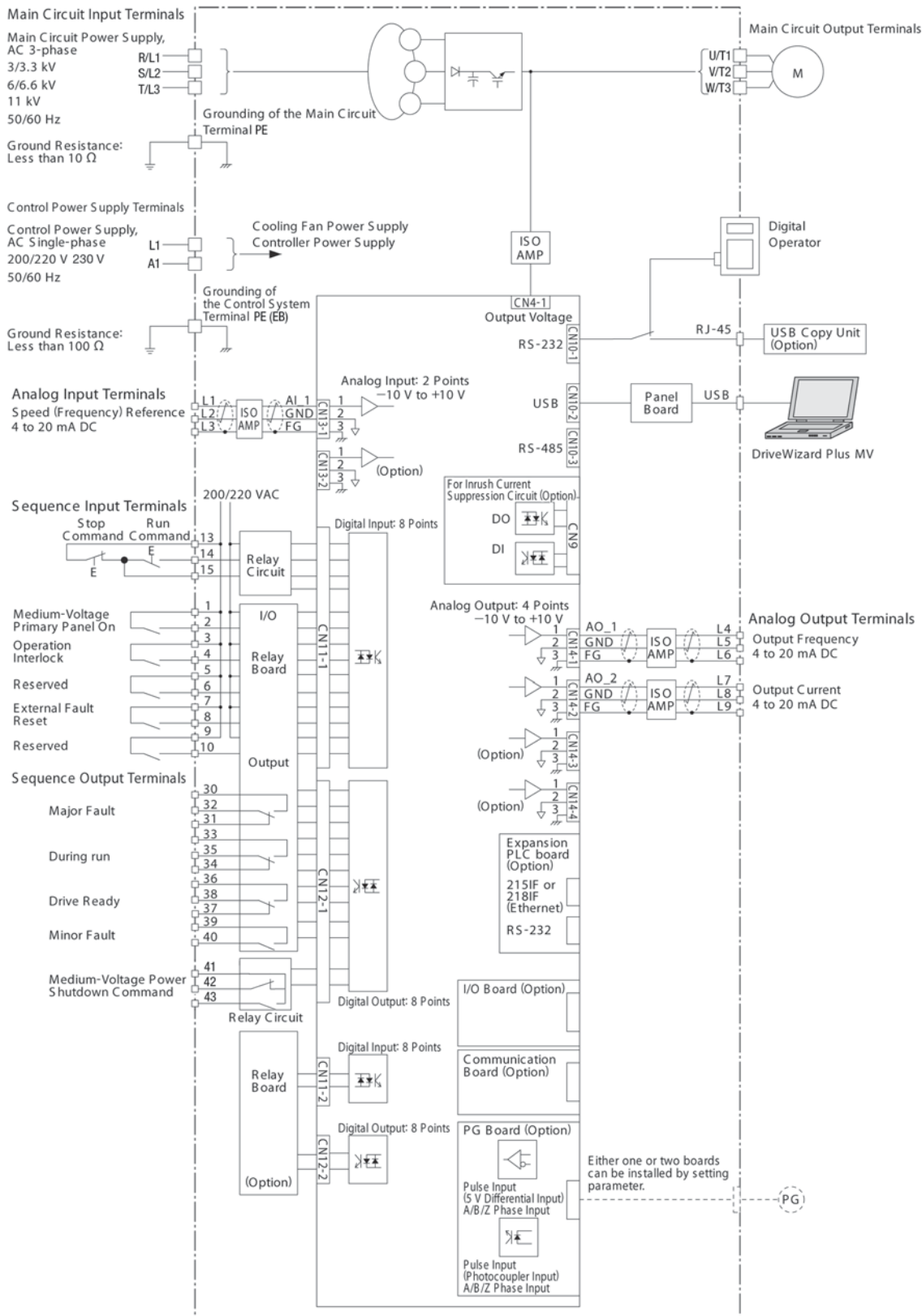



## Terminal Functions

### Main Circuit Terminals (Common to all models)

Type	Terminal No.	Terminal Function
Main Circuit Input Terminals	R/L1	3000/3300 VAC, 6000/6600 VAC, 11000 VAC 50/60 Hz
	S/L2	
	T/L3	
Main Circuit Output Terminals	U/T1	3000/3300 VAC, 6000/6600 VAC, 11000 VAC 50/60 Hz
	V/T2	
	W/T3	
Ground Terminal	PE	Grounding of the main circuit
Control Power Supply Input Terminal	L1	230 VAC 50/60 Hz
	N	
Ground Terminal	PE (ED)	Grounding of the control system

### Control Circuit Terminals (Common to all models)

Type	Terminal No.	Signal Name	Signal Level	Terminal Function
Analog Input Terminals	L1	Speed (Frequency) Reference	4 to 20 mA DC/0 to 60 Hz	Speed (frequency) reference input signal
	L2			Ground
	L3			Shield ground
Analog Output Terminals	L4	Output Frequency	4 to 20 mA DC/0 to 60 Hz	Output frequency reference output signal
	L5			Ground
	L6			Shield ground
	L7	Output Current	4 to 20 mA DC/0 to 150%	Output current reference output signal
	L8			Ground
	L9			Shield ground
Sequence Input Terminals	1	Medium-Voltage Primary Panel On	Contact input 220 VAC/8 mA	ON: Turning on (closed at default)
	2			
	3	Operation Interlock	Contact input 220 VAC/8 mA	ON: Established (closed at default)
	4			
	5	Reserved	—	—
	6			
	7	External Fault Reset	Contact input 220 VAC/8 mA	ON: Reset
	8			
	9	Reserved	—	—
	10			
	13	Run Command/ Stop Command	Contact input 220 VAC/8 mA	ON: Run
14	OFF: Stop			
Sequence Output Terminals	30	Major Fault	Transfer contact relay, output relay board 220 VAC/15A, 110 VAC/15A, 24 VDC/15A	Open: Major Fault
	31			
	32			
	33	During run	Transfer contact relay, output relay board 220 VAC/15A 110 VAC/15A 24 VDC/15A	Closed: During run
	34			
	35			
	36	Drive Ready	Transfer contact relay, output relay board 220 VAC/15A 110 VAC/15A 24 VDC/15A	Closed: Drive Ready
	37			
	38	Minor Fault	N.O. contact relay, output relay board 220 VAC/15 A 110 VAC/15A 24 VDC/15A	Closed: Minor Fault
	39			
	40	Medium-Voltage Main Circuit Shutdown Command	N.O. contact output 220 VAC/10A, 24 VDC/10A	Common
	41			Closed (N.C.) Turning off (closed when power is off)
	42			Open (N.O.) Turning on (open when power is off)
	43			Common
91	Common			
92	Open (N.O.) Turning on (open when power is off)			

# Software Functions

Loaded with a variety of software functions, enabling system optimization to your application

## Functions at Start and Stop

- 

**Optimal deceleration without needing to set the deceleration time.**  
Drive slows the application smoothly controlling DC bus voltage.
- 

**Suitable for applications with occasional stopping, such as emergency stopping of large inertia loads**  
Reduces the deceleration time at emergency stops.  
Note: The result may vary depending on conditions such as motor characteristics.
- 

**Start a coasting motor.**  
Automatically brings a coasting motor back to the target frequency without using a motor encoder.
- 

**Accelerate and decelerate smoothly with large inertia loads.**  
Drive prevents speed loss by holding the output frequency at a constant level during acceleration and deceleration.
- 

**Switch easily between accel/ decel times.**  
Switch acceleration and deceleration rates when running two motors from the same drive, or assign specific accel/decel rates when operating at high speed or at low speed.
- 

**Braking the motor by applying direct current when starting**  
Enables stopping of a coasting motor for restarting or quickly generating motor magnetic flux (initial excitation) to obtain high starting torque.





Indicates software functions new to FSDrive -MV1000, contrasting them with the existing FSDrive -MV1S.

Note: Only major functions are presented here.

## Reference Functions

- 

**Limit motor speed.**  
Set speed limits and eliminate the need for extra peripheral devices and extraneous hardware.
- 

**Skip over troublesome resonant frequencies.**  
Drive can be programmed to avoid machine resonance problems by avoiding constant speed operation at certain speeds.
- 

**Improved operability.**  
Momentarily hold the operating frequency during acceleration or deceleration as the load is lowered or raised.
- 

**Balances the load automatically between motors.**  
Calculates the ratio of the load torque and adjusts motor speed accordingly.

## Functions for Top Performance

- 

**Supporting both IMs and SMs**  
Runs wound rotor synchronous motors (SM) as well as induction motors (IM).
- 

**Transfer from line to drive, drive to line \***  
Perform transfer operation from line to drive and drive to line without stopping motors  
\*: An input voltage detector needs to be added.
- 

**Automatically runs at top efficiency.**  
The drive supplies voltage to the motor relative to the speed and load so that the application is for operating at the most efficient level.
- 

**Achieve high levels of performance.**  
The drive comes with current vector control capabilities for high performance applications.

Multi-speed Operation

**Multi-speed operation is possible.**  
Enables speed selection in up to 17 steps. Speed selection is even possible during operation by using multi-function digital inputs.

NEW

PID Control

**Automatic PID control**  
The internal PID controller fine-tunes the output frequency for precise control of pressure, flow, or other variables.

NEW

Motor 2 Switch

**One drive runs two motors.**  
Use a single drive to operate two different motors. Cannot be used with PM motors.

V/f Control (Multi-motor Drive)

**Controlling multiple motors**  
Runs multiple motors simultaneously in parallel.

Overtorque Detection

**Improving reliability in continuous operation while protecting the system**  
Shuts off the overtorque signal when the motor torque goes beyond the overtorque detection level. This signal can be utilized as an interlock signal to protect the system.

Torque Limit

**Improving reliability in continuous operation while protecting the system**  
Helps protect the system by restricting motor torque to a preset level. The output frequency is controlled according to the overload status.

NEW

Timer Function

**No need for extra hardware**  
Control timing by opening and closing the output signal relative to the input signal.

Continuous Run during Reference Loss

**Keeps the application running**  
Maintains continuous operation even if the controller fails and the frequency reference is lost.

Fault Retry

**Improving reliability in continuous operation**  
Resets the system automatically after performing self-diagnostics when the drive detects an error. A number of retries up to 10 can be selected.

## Protective Functions

Momentary Power Loss Compensation

**Keep running even during a momentary power loss \***  
Automatically restarts the motor and keeps the application running even during a momentary power loss.

\*: A UPS unit is required in addition to supply control power.

Excessive Deceleration Prevention

**Preventing motor stall due to overvoltage**  
Controls the deceleration rate automatically by monitoring the DC-bus voltage to prevent overvoltage during deceleration.

Load Speed Display

**Monitor actual speed of the motor and load.**  
Monitors let the user keep track of motor rotations and line speed.

NEW

Copy Function

**Save parameter setting to the digital operator.**  
Copy all parameter settings to the operator keypad, and then transfer those settings to another drive. Saves valuable setup and maintenance time.

KEB Function

**Continuous operation even during a momentary power loss without base-blocking \***  
Uses regenerated energy from the motor to bring the application to a stop rather than simply letting it coast.

\*: A UPS unit is required in addition to supply control power.

# Drive Capacity Selection

## Examination of capacity 1

### For blower motor

When commercial power operation method is changed to speed control method, the applicable drive capacity is determined as follows.

Example: Motor rating: 500 kW 4P, 3 kV at 50 Hz

Assuming that:

- Motor rated current : 120 A
- Maximum value of actual operation load current: 95 A. For this applicable drive capacity, rated current 100A (nominal capacity 570 kVA) should be selected (100 A > 95 A).

## Examination of capacity 2

### For extruder motor

Example: Motor rating: 400 kW 6P, 3.3 kV at 60 Hz

Assuming that:

- Motor rated current: 88 A
- Required overload tolerance: 120% for 60 seconds. The applicable drive tolerance is shown below considering the allowance of 10%:  
 $88 \text{ A} \times 1.3 = 115 \text{ A}$

Therefore, for this applicable drive capacity, rated current 140 A (nominal capacity 800 kVA) should be selected. (140 A > 115 A)

## Examination of capacity 3

### For cement kiln motor

Example: Motor rating: 500 kW, 6P 6.6 kV at 60 Hz

Assuming that:

- Motor rated current: 53 A
- Required overload tolerance: 250% for 60 seconds.

The applicable drive capacity is shown below considering the allowance of 10%:

$$53 \text{ A} \times 2.6 = 138 \text{ A}$$

Therefore, for this applicable drive capacity, rated current 140 A (nominal capacity 1600 kVA) should be selected (140 A > 138 A).

## Global Service Network



Region	Service Area	Service Location	Service Agency	Telephone/Fax
Europe	Europe, South Africa	Frankfurt	<b>1</b> YASKAWA EUROPE GmbH	Tel. +49-6196-569-300 Fax +49-6196-569-398
North America	Canada	Montreal	<b>2</b> YASKAWA MOTOMAN CANADA	Tel. +1-905-813-5900 Fax +1-905-813-5911
	Mexico	Mexico City	<b>3</b> PILLAR MEXICANA. S.A. DE C.V.	Tel. +52-555-660-5553 Fax +52-555-651-5573
South America	South America	São Paulo	<b>4</b> YASKAWA ELÉTRICO DO BRASIL LTDA.	Tel. +55-11-3585-1100 Fax +55-11-5581-8795
	Colombia	Santafe De Bogota	<b>5</b> VARIADORES LTD.A.	Tel. +57-1-428-4225 Fax +57-1-428-2173
Asia, Oceania	Japan	Tokyo, offices nationwide	<b>6</b> YASKAWA ELECTRIC ENGINEERING CORPORATION	Tel. +81-4-2931-1810 Fax +81-4-2931-1811
	South Korea	Seoul	<b>7</b> YASKAWA ELECTRIC KOREA CORPORATION	Tel. +82-2-784-7844 Fax +82-2-784-8495
	China	Shanghai (HQ), Beijing, Guangzhou, Chengdu	<b>8</b> YASKAWA ELECTRIC (SHANGHAI), Co. Ltd.	Headquarters Tel. +86-21-5385-2200 Fax +86-21-5385-3299
	Taiwan	Taipei	<b>9</b> YATEC ENGINEERING CORPORATION	Tel. +886-2-6635-7030 Fax +886-2-2298-7010
	East Asia, Oceania	Singapore	<b>10</b> YASKAWA ELECTRIC (SINGAPORE) Pte. Ltd.	Tel. +65-6282-3003 FAX +65-6289-3003
	Thailand	Bangkok	<b>11</b> YASKAWA ELECTRIC (THAILAND) Co. Ltd.	Tel. +66-2-693-2200 FAX +66-2-693-4200
	India	Mumbai	<b>12</b> LARSEN & TOUBRO LIMITED	Tel. +91-22-67226200 Tel. +91-22-27782230 FAX +91-22-27783032
	Indonesia	Jakarta	<b>13</b> PT. YASKAWA ELECTRIC INDONESIA	Tel. +62-21-57941845 FAX +62-21-57941843





**YASKAWA Europe GmbH**

Drives & Motion Division  
Hauptstr. 185  
65760 Eschborn  
Germany

Tel: + 49 (0) 6196-569 300  
Fax: + 49 (0) 6196-569 398  
info@yaskawa.eu.com  
www.yaskawa.eu.com