

# MECHATROLINK-III Communications Reference Type SERVOPACKs

## SGDV-□□□□21 (For Rotary Servomotors)

## SGDV-□□□□25 (For Linear Servomotors)



### Model Designations

**S G D V-**

Σ-V Series  
SGDV  
SERVOPACK

**R70**

1st+2nd+3rd digits

**A**

4th digit

**21**

5th+6th digits

**A**

7th digit

**000**

8th+9th+10th digits

**00**

11th+12th digits

**0**

13th digit

1st+2nd+3rd digits

Current

Voltage	Code	Applicable Servomotor Max. Capacity kW
Three-phase 200 V	R70*1	0.05
	R90*1	0.1
	1R6*1	0.2
	2R8*1	0.4
	3R8	0.5
	5R5*1	0.75
	7R6	1.0
	120*2	1.5
	180	2.0
	200	3.0
	330	5.0
	470	6.0
	550	7.5
	590	11
780	15	
Three-phase 400 V	1R9	0.5
	3R5	1.0
	5R4	1.5
	8R4	2.0
	120	3.0
	170	5.0
	210	6.0
	260	7.5
	280	11
370	15	

4th digit

Power Supply Voltage

Code	Specifications
F	Single-phase 100 VAC
A	Three-phase 200 VAC
D	Three-phase 400 VAC

5th+6th digits

Interface

Code	Specifications
21	MECHATROLINK-III communications Reference Type (for rotary servomotors)
25	MECHATROLINK-III communications Reference Type (for linear servomotors)

7th digit

Design Revision Order

A, B...

8th+9th+10th digits

Options (hardware)

Code	Specifications
000	Base-mounted (standard)
001	Rack-mounted
002	Varnished
003	Rack-mounted and Varnished
008	Single-phase 200 VAC input (Model: SGDV-120A21A008000)
020	Dynamic brake (400 V SERVOPACKs only)

11th+12th digits

Options (software)

Code	Specifications
00	Standard

13th digit

Options (parameter)

Code	Specifications
0	Standard

\*1: These amplifiers can be powered with single or three-phase.

\*2: Single-phase 200 VAC SERVOPACKs are also available. (Model: SGDV-120A21A008000)

\*3: SERVOPACKs of 6 kW or more are duct-ventilated.

Note: If the option codes digits 8 to 13 are all zeros, they are omitted.

## Features

- **Real-time communications**

MECHATROLINK-III communications enable high-speed control for 62 stations at a transmission speed of 100 Mbps in a transmission cycle from 125  $\mu$ s to 4 ms (user setting). Such a high transmission speed allows real-time transmission of various data required for control.

- **Cost savings**

The 62 stations can be connected to a single MECHATROLINK-III transmission line, so wiring costs and time are greatly reduced. Also, only one signal connector is required on the host controller. And, the all-digital network eliminates the need for conversion from digital to analog for speed/torque references and for a pulse generator to generate position references.

- **High-precision motion control**

The SGD V SERVOPACK when connected to the host controller in the MECHATROLINK-III network provides not only torque, position, and speed control but also synchronized phase control that requires advanced control technology. The control mode can be changed online so that the machine can move smoothly in complex motions with great efficiency.

## Ratings

### Single-phase 200 V

SERVOPACK Model SGD V-□□□□	R70A	R90A	1R6A	2R8A	5R5A	120A*	
Applicable Servomotor Max. Capacity	kW	0.05	0.1	0.2	0.4	0.75	1.5
Continuous Output Current	Arms	0.66	0.91	1.6	2.8	5.5	11.6
Max. Output Current	Arms	2.1	2.9	5.8	9.3	16.9	28
Regenerative Resistors		None or external			Built-in or external		
Main Circuit		Single-phase 200 to 230 VAC+10% to -15% 50/60 Hz					
Control Circuit		Single-phase 200 to 230 VAC+10% to -15% 50/60 Hz					

\*: The rated voltage is 220 to 230 VAC for the SGD V-120A21A008000 SERVOPACK.

### Three-phase 200 V

SERVOPACK Model SGD V-□□□□	R70A	R90A	1R6A	2R8A	3R8A	5R5A	7R6A	120A	180A	200A	330A	470A	550A	590A	780A	
Applicable Servomotor Max. Capacity	kW	0.05	0.1	0.2	0.4	0.5	0.75	1.0	1.5	2.0	3.0	5.0	6	7.5	11	15
Continuous Output Current	Arms	0.66	0.91	1.6	2.8	3.8	5.5	7.6	11.6	18.5	19.6	32.9	46.9	54.7	58.6	78
Max. Output Current	Arms	2.1	2.9	5.8	9.3	11	16.9	17	28	42	56	84	110	130	140	170
Regenerative Resistors		None or external				Built-in or external						External				
Main Circuit		Three-phase 200 to 230 VAC+10% to -15% 50/60 Hz														
Control Circuit		Single-phase 200 to 230 VAC+10% to -15% 50/60 Hz														

### Three-phase 400 V

SERVOPACK Model SGD V-□□□□	1R9D	3R5D	5R4D	8R4D	120D	170D	210D	260D	280D	370D	
Applicable Servomotor Max. Capacity	kW	0.5	1.0	1.5	2.0	3.0	5.0	6	7.5	11	15
Continuous Output Current	Arms	1.9	3.5	5.4	8.4	11.9	16.5	20.8	25.7	28.1	37.2
Max. Output Current	Arms	5.5	8.5	14	20	28	42	55	65	70	85
Regenerative Resistors		Built-in or external						External			
Main Circuit		Three-phase 380 to 480 VAC+10% to -15% 50/60 Hz									
Control Circuit		24 VDC $\pm$ 15%									

Note: The entire over voltage category is III.

### ● SERVOPACK Overload Characteristics

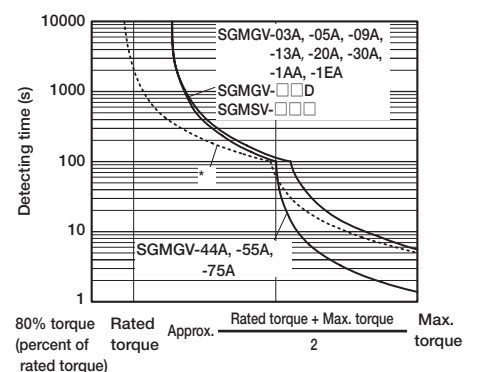
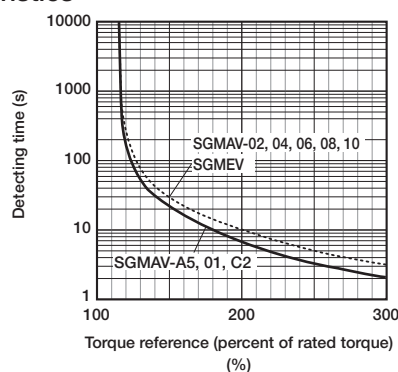
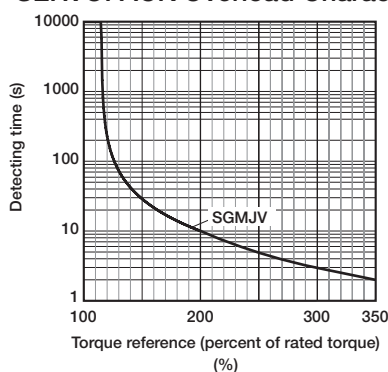

Note: Overload characteristics shown above do not guarantee continuous duty of 100% or more output. Use a servomotor with effective torque within the continuous duty zone of *Torque-Motor Speed Characteristics*.

\*: The dotted line indicates the characteristics of a combination of SGD V-200A SERVOPACKs and SGMGV-30A servomotors.

## Specifications

Items		Specifications		
Control Method		IGBT PWM control, sine-wave driven		
Feedback	Rotary Servomotors	Serial encoder: 13-bit (incremental encoder) : 17-bit (incremental/absolute encoder) : 20-bit (incremental/absolute encoder)		
	With Linear Servomotors	Absolute linear scale (The signal resolution varies depending on the absolute linear scale.) Incremental linear scale (The signal resolution varies depending on the incremental linear scale or serial converter unit.)		
Operating Conditions	Ambient Temperature	0 to +55°C		
	Storage Temperature	-20 to +85°C		
	Ambient Humidity	90%RH or less	With no freezing or condensation	
	Storage Humidity	90%RH or less		
	Vibration Resistance	4.9 m/s		
	Shock Resistance	19.6 m/s		
	Protection Class	IP10	An environment that satisfies the following conditions. • Free of corrosive or flammable gases • Free of exposure to water, oil, or chemicals • Free of dust, salts, or iron dust	
	Pollution Degree	2		
	Altitude	1000 m or less		
Others	Do not use SERVOPACKs in the following locations: • Locations subject to static electricity noise, strong electromagnetic/magnetic fields, radioactivity			
Applicable Standards (Pending)		UL508C EN50178, EN55011/A2 group1 classA, EN61000-6-2, EN61800-3, EN61800-5-1, EN954-1, IEC61508-1 to 4		
Mounting		Standard: Base-mounted Optional: Rack-mounted, Duct-ventilated		
Performance	Speed Control Range		1:5000 (The lower limit of the speed control range must be lower than the point at which the rated torque does not cause the servomotor to stop.)	
	Speed Regulation	Load Fluctuation	0% to 100% load: ±0.01% max. (at rated speed)	
		Voltage Fluctuation	Rated voltage: ±10% : 0% (at rated speed)	
		Temperature Fluctuation	25±25°C : ±0.1% max. (at rated speed)	
	Torque Control Tolerance (Repeatability)		±1%	
Soft Start Time Setting		0 to 10 s (can be set individually for acceleration and deceleration.)		
Communications	RS-422A Communications	Interface	Digital operator (JUSP-OP05A-1-E), personal computer (can be connected with SigmaWin+)	
		1:N communications	RS-422A port: N=15 max. available	
		Axis address setting	Set by parameters	
	USB Communications	Interface	Personal computer (can be connected with SigmaWin+.)	
	Communications Standard	Compliant with USB1.1 standard (12 Mbps)		
Display		CHARGE indicator		
Analog Monitor		Number of points: 2 Output voltage: ±10 VDC (linearity effective range ±8 V) Resolution: 16 bit Accuracy: ±20 mV (Typ) Max. output current: ±10 mA Settling time (±1%): 1.2 ms (Typ)		
Dynamic Brake (DB)		Activated when a servo alarm or overtravelling (OT) occurs, or when the power supply for the main circuit or servomotor is OFF.		
Regenerative Processing		Included (For more information, refer to the previous page.)		
Overtravelling (OT) Prevention		Dynamic brake stop at P-OT or N-OT, deceleration to a stop, or free run to a stop		
Protective Functions		Overcurrent, Overvoltage, low voltage, overload, regeneration error, etc.		
Utility Functions		Gain adjustment, alarm history, JOG operation, origin search, etc.		
Safety Functions	Input	/HWBB1, /HWBB2: Baseblock signal for power module		
	Output	EDM1: Status monitor (fixed output) of built-in safety circuit		
	Applicable Standards (Pending)	EN954 category 3, IEC61508 SIL2		
Option Module		Fully-closed Module		

\*1: Speed regulation is defined as follows:

$$\text{Speed regulation} = \frac{\text{No-load motor speed} - \text{Total load motor speed}}{\text{Rated motor speed}} \times 100\%$$

The motor speed may change due to voltage fluctuation or temperature fluctuation.

The ratio of speed changes to the rated speed represent speed regulation due to voltage and temperature fluctuations.

\*2: Perform risk assessment for the system and confirm that the safety requirements for the standards are fulfilled before using the HWBB function.

## Specifications

### ● Rotary Servomotors

Items		Specifications		
I/O Signal	Encoder Output Pulses	Phase A, phase B, phase C: line driver output The number of dividing pulse: Any setting ratio is available.		
	Sequence Input	Fixed Input	SEN signal	
		Input Signals which can be allocated	Number of Channels	7 channels
	Sequence Output	Output Signals which can be allocated	Function	<ul style="list-style-type: none"> <li>• Homing deceleration switch signal (/DEC)</li> <li>• External latch signals (/EXT 1 to 3)</li> <li>• Forward run prohibited (/P-OT), reverse run prohibited (/N-OT)</li> <li>• Forward external torque limit (/P-CL), reverse external torque limit (/N-CL)</li> </ul> Positive and negative logic can be changed.
			Fixed Output	Servo alarm (ALM)
			Number of Channels	3 channels
		Function	<ul style="list-style-type: none"> <li>• Positioning completion (/COIN)</li> <li>• Speed limit detection (/VLT)</li> <li>• Speed coincidence detection (/V-CMP)</li> <li>• Brake (/BK)</li> <li>• Rotation detection (/TGON)</li> <li>• Warning (/WARN)</li> <li>• Servo ready (/S-RDY)</li> <li>• Near (/NEAR)</li> <li>• Torque limit detection (/CLT)</li> </ul> Positive and negative logic can be changed.	
Panel Operator	Display Unit	One 7-segment LED (red) and three LED indicators for MECHATROLINK communications (green)		
	Switch	Rotary switch: 16 positions×2, DIP switch: 4 poles		
MECHATROLINK Communications	Communications Protocol	MECHATROLINK-III		
	Transmission Speed	100 Mbps		
	Transmission Cycle	125 μs, 250 μs, 500 μs, 750 μs, 1 ms to 4 ms (increments of 0.5 ms)		
	Number of Words for Link Transmission	Can be switched between 16-bytes/station, 32-bytes/station and 48-bytes/station.		
	Station Address	03H to EFH (max. number of slaves: 62)		
Command Method	Performance	Position control, speed control, and torque control through MECHATROLINK communications		
	Command Input	MECHATROLINK commands (for sequence, motion, data setting/reference, monitor, adjustment, and other commands.)		

### ● Linear Servomotors

Items		Specifications		
I/O Signal	Encoder Output Pulses	Phase A, phase B, phase C: line driver output The number of dividing pulse: Any setting ratio is available.		
	Sequence Input	Fixed Input	SEN signal	
		Input Signals which can be allocated	Number of Channels	7 channels
	Sequence Output	Output Signals which can be allocated	Function	<ul style="list-style-type: none"> <li>• Homing deceleration switch signal (/DEC)</li> <li>• External latch signals (/EXT 1 to 3)</li> <li>• Forward run prohibited (/P-OT), reverse run prohibited (/N-OT)</li> <li>• Forward external force limit (/P-CL), reverse external force limit (/N-CL)</li> </ul> Positive and negative logic can be changed.
			Fixed Output	Servo alarm (ALM)
			Number of Channels	3 channels
		Function	<ul style="list-style-type: none"> <li>• Positioning completion (/COIN)</li> <li>• Speed limit detection (/VLT)</li> <li>• Speed coincidence detection (/V-CMP)</li> <li>• Brake (/BK)</li> <li>• Servomotor movement detection (/TGON)</li> <li>• Warning (/WARN)</li> <li>• Servo ready (/S-RDY)</li> <li>• Near (/NEAR)</li> <li>• Force limit detection (/CLT)</li> </ul> Positive and negative logic can be changed.	
Panel Operator	Display Unit	One 7-segment LED (red) and three LED indicators for MECHATROLINK communications (green)		
	Switch	Rotary switch: 16 positions×2, DIP switch: 4 poles		
MECHATROLINK Communications	Communications Protocol	MECHATROLINK-III		
	Transmission Speed	100 Mbps		
	Transmission Cycle	125 μs, 250 μs, 500 μs, 750 μs, 1 ms to 4 ms (increments of 0.5 ms)		
	Number of Words for Link Transmission	Can be switched between 16-bytes/station, 32-bytes/station and 48-bytes/station.		
	Station Address	03H to EFH (max. number of slaves: 62)		
Command Method	Performance	Position control, speed control, and force control through MECHATROLINK communications		
	Command Input	MECHATROLINK commands (for sequence, motion, data setting/reference, monitor, adjustment, and other commands.)		

## Power Supply Capacities and Power Losses

The following table shows SERVOPACK's power supply capacities and power losses at the rated output.

Main Circuit Power Supply	Applicable Servomotor Max. Capacity kW	SERVOPACK Model SGD V-	Power Supply Capacity kVA	Output Current Arms	Main Circuit Power Loss W	Regenerative Resistor Power Loss	Control Circuit Power Loss W	Total Power Loss W
						W		
Single-phase 200 V	0.05	R70A	0.2	0.66	5.2	—	17	22.2
	0.1	R90A	0.3	0.91	7.4			24.4
	0.2	1R6A	0.7	1.6	13.7			30.7
	0.4	2R8A	1.2	2.8	24.9			41.9
	0.75	5R5A	1.9	5.5	52.7	8	77.7	
	1.5	120A	4	11.6	68.2	10	22	100.2
Three-phase 200 V	0.05	R70A	0.2	0.66	5.1	—	17	22.1
	0.1	R90A	0.3	0.91	7.3			24.3
	0.2	1R6A	0.6	1.6	13.5			30.5
	0.4	2R8A	1	2.8	24.0			41.0
	0.5	3R8A	1.4	3.8	20.1	8	45.1	
	0.75	5R5A	1.6	5.5	43.8		68.8	
	1.0	7R6A	2.3	7.6	53.6	10	78.6	
	1.5	120A	3.2	11.6	65.8		97.8	
	2.0	180A	4	18.5	111.9	16	22	149.9
	3.0	200A	5.9	19.6	113.8		161.4	
	5.0	330A	7.5	32.9	263.7	36	27	326.7
	6.0	470A	10.7	46.9	279.4	(180)*1	33	312.4
	7.5	550A	14.6	54.7	357.8	(350)*2		390.8
	11	590A	21.7	58.6	431.7	48	479.7	
15	780A	29.6	78	599.0	647.0			
Three-phase 400 V	0.5	1R9D	1.1	1.9	24.6	14	21	59.6
	1.0	3R5D	2.3	3.5	46.1			81.1
	1.5	5R4D	3.5	5.4	71.3			106.3
	2.0	8R4D	4.5	8.4	77.9	28	25	130.9
	3.0	120D	7.1	11.9	108.7			161.7
	5.0	170D	11.7	16.5	161.1	36	24	221.1
	6.0	210D	12.4	20.8	172.7	180 *3	27	199.7
	7.5	260D	14.4	25.7	218.6			245.6
	11	280D	21.9	28.1	294.6			324.6
15	370D	30.6	37.2	403.8	350 *4	30	433.8	

\*1: For the optional JUSP-RA04-E regenerative resistor unit.

\*2: For the optional JUSP-RA05-E regenerative resistor unit.

\*3: For the optional JUSP-RA18-E regenerative resistor unit

\*4: For the optional JUSP-RA19-E regenerative resistor unit.

Notes: 1 SGD V-R70A, -R90A, -1R6A, and -2R8A SERVOPACKs do not have built-in regenerative resistors.

If the regenerative energy exceeds the specified value, connect an external regenerative resistor (optional).

2 SGD V-470A, -550A, -590A, -780A, -210D, -260D, -280D, -370D SERVOPACKs do not have built-in regenerative resistors.

Be sure to connect a regenerative resistor unit (optional) or an external regenerative resistor (optional). For selection details, refer to page 364.







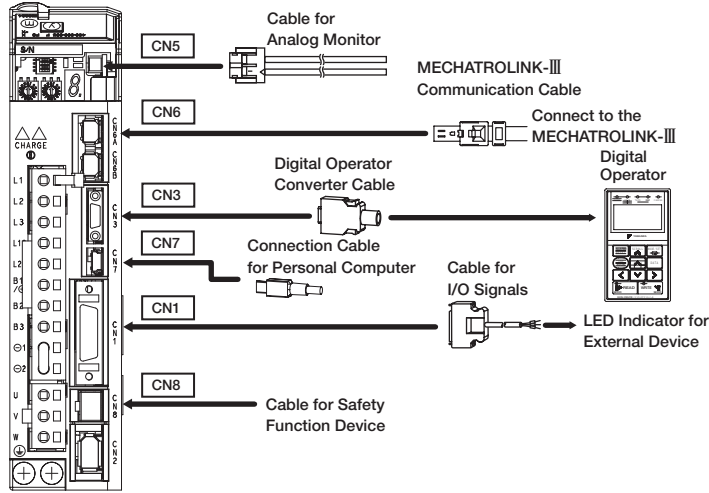

3 Regenerative resistor power losses are allowable losses. Take the following action if this value is exceeded.

- Remove the lead or short bar that is short-circuiting the SERVOPACK main circuit terminal B2 and B3. (SGDV-3R8A, -5R5A, -7R6A, -120A, -180A, -200A, -330A, or 400-V class SERVOPACKs.)
- Install an external regenerative resistor (optional). For selection details, refer to page 364.

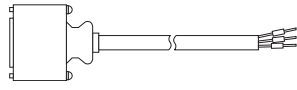
## Selecting Cables

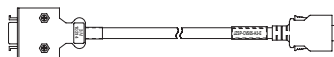
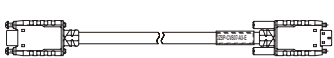
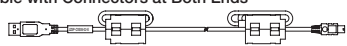
- Cables for **CN1** **CN3** **CN5** **CN6** **CN7** **CN8** (MECHATROLINK-III Communications Reference Type SERVOPACKs)

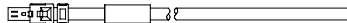

Name		Length	Order No.	Specifications	Details
<b>CN1</b> Cables for I/O Signals	Connector Kit		JZSP-CSI9-2-E	Soldered 	(1)
	Connector Terminal Converter Unit	0.5 m	JUSP-TA26P-E	Terminal Block and Connection Cable 	(2)
		1 m	JUSP-TA26P-1-E		
		2 m	JUSP-TA26P-2-E		
	Cable with Loose wire at One End	1 m	JZSP-CSI02-1-E		(3)
		2 m	JZSP-CSI02-2-E		
3 m		JZSP-CSI02-3-E			
<b>CN3</b>	Digital Operator		JUSP-OP05A-1-E	With Connection Cable (1 m) 	(4)
	Digital Operator Converter Cable	0.3 m	JZSP-CVS05-A3-E	Cable with Connectors at Both Ends 	(5)
			JZSP-CVS07-A3-E	With Lock Screws 	(6)
<b>CN7</b> Connection Cables for Personal Computer		2.5 m	JZSP-CVS06-02-E	Cable with Connectors at Both Ends 	(7)
<b>CN6A</b> <b>CN6B</b> MECHATROLINK-III Communication Cable	Cables with Connectors at Both Ends	0.2 to 50 m	JEPMC- 6012-□□-		(8)
	Cables with Connectors at Both Ends (With Ferrite Core)	10 to 50 m	JEPMC-W6013-□□-E		(9)
	Cable with Loose Wire at One End	0.5 to 50 m	JEPMC-W6014-□□-E		(10)
<b>CN5</b> Cables for Analog Monitor		1 m	JZSP-CA01-E	SERVOPACK End 	(11)
<b>CN8</b> Cable for Safety Function Device	Cables with Connector	3 m	JZSP-CVH03-03-E JZSP-CVH03-03-E-G3		(12)
	Connector kit		Contact Tyco Electronics AMP K.K. Product name : Industrial Mini I/O D-shape Type1 Plug Connector Kit Model : 2013595-1		

\*1 : A converter cable is required to use  $\Sigma$ -III series digital operators (model: JUSP-OP05A) for  $\Sigma$ -V series SERVOPACKs.

\*2 : A converter cable with lock screws is required to securely connect the digital operator cable.

\*3 : When using the safety function, connect this cable to the safety devices.

Even when not using the safety function, use SERVOPACKs with the Safe Jumper Connector (model: JZSP-CVH05-E) connected.

\*4 : Use the connector kit when you make cables yourself.



Selecting Cables

(1) Connector Kit for CN1

Use the following connector and cable to assemble the cable. The CN1 connector kit includes one case and one connector.

Connector Kit Model	Case		Connector	
	Model	Qty	Model	Qty
JZSP-CSI9-2-E	10326-52A0-008*	1 set	10126-3000PE* (Soldered)	1

\* : Manufactured by Sumitomo 3M Ltd.

• Cable Size

Item	Specifications
Cable	Use twisted-pair or twisted-pair shielded wire.
Applicable Wires	AWG24, 26, 28, 30
Cable Finished Diameter	16 dia. max.

• External Dimensions of Case (Units: mm)

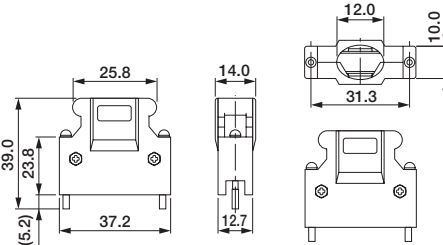

• External Dimensions of Connector (Units: mm)

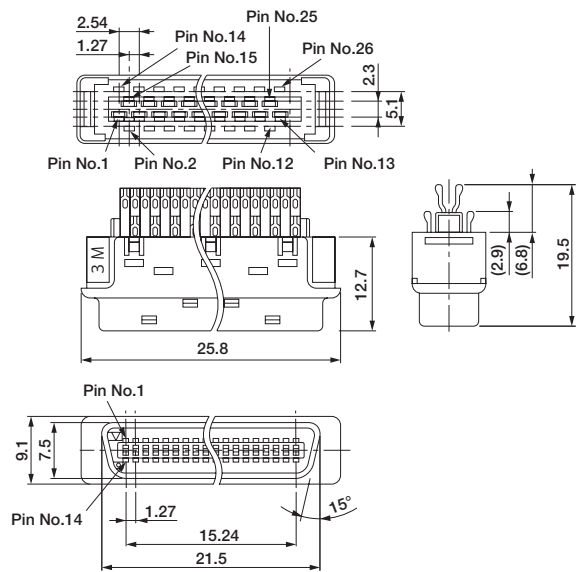

(2) Connector Terminal Converter Unit for CN1

• Configurations

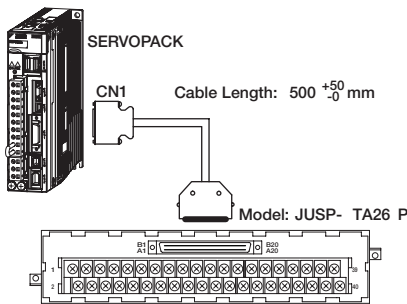

• External Dimensions of Terminal Block (Units: mm)

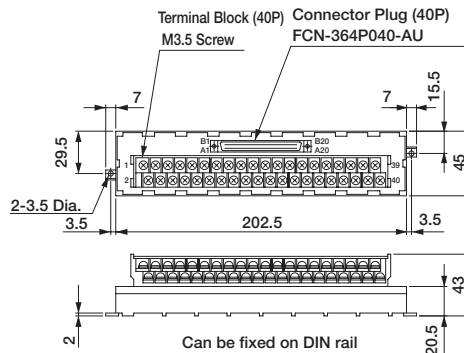

• Dimensional Drawings of Cable

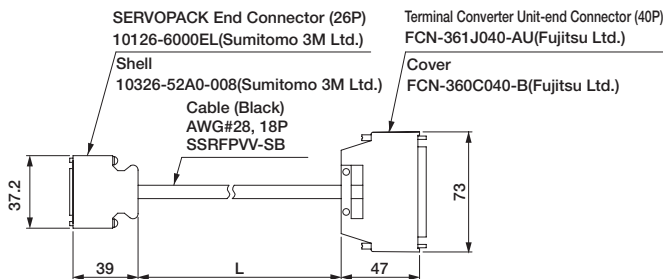

Model	Cable Length (L)	Approx. Mass
JUSP-TA26P-E	0.5 m	100 g
JUSP-TA26P-1-E	1 m	200 g
JUSP-TA26P-2-E	2 m	400 g

Note: The pin number in the SERVOPACK connector and the pin number in the terminal block are the same. Pin numbers 1 to 26 are used in the terminal block. Do not use a pin number of 27 or higher.  
If assembling cables, refer to • Cable with Loose Wires at One End for CN1 Connection Diagram of JZSP-CSI02-□-E Cable on the next page.

Selecting Cables

(3) Cable with Loose Wires at One End for CN1  
External Dimensions of Cable (Units: mm)

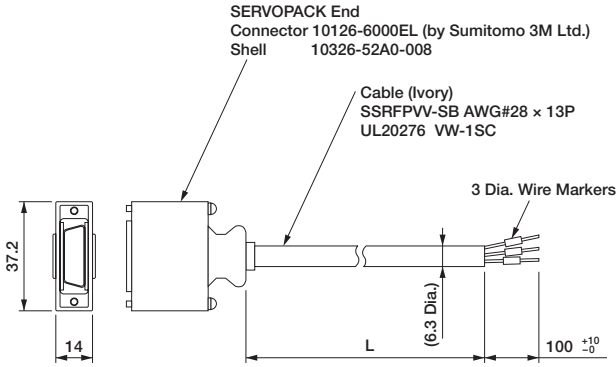

Model	Cable Length
JZSP-CSI02-1-E	1 m
JZSP-CSI02-2-E	2 m
JZSP-CSI02-3-E	3 m

● Cable with Loose Wires at One End for CN1  
Connection Diagram of JZSP-CSI02-□-E Cable

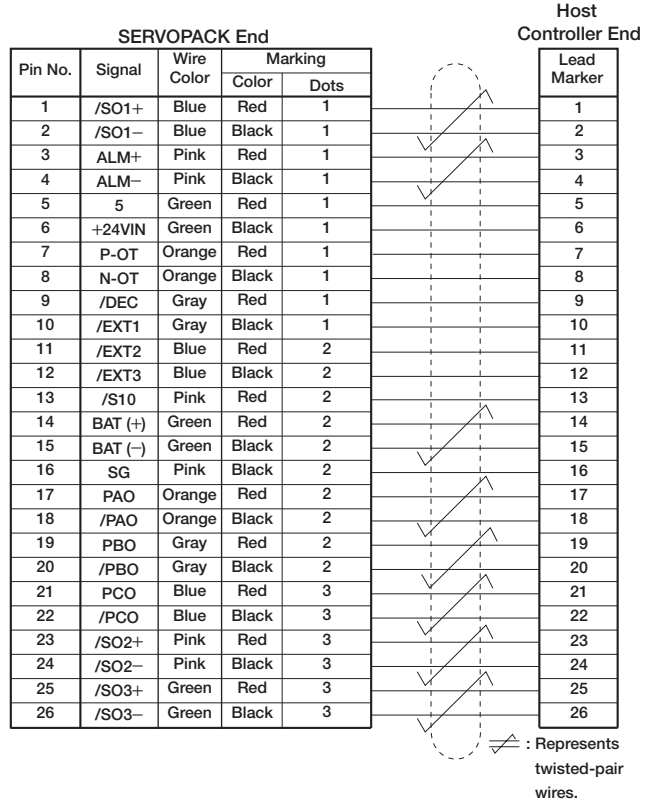

(4) Digital Operator (Model: JUSP-OP05A-1-E)  
(Units: mm)

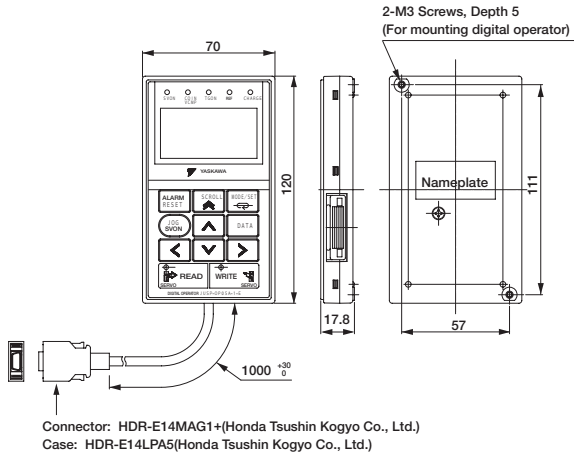

(5) Digital Operator Converter Cable for CN3

(Model: JZSP-CVS05-A3-E)  
A converter cable is required to use  $\Sigma$ -III series digital operators (model: JUSP-OP05A) for  $\Sigma$ -V series SERVOPACKs.

● External Dimensions (Units: mm)

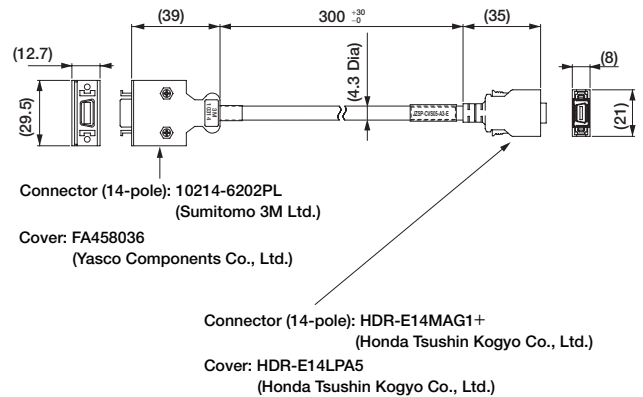

(6) Digital Operator Converter Cable for CN3  
(Model: JZSP-CVS07-A3-E)

A converter cable is required when connecting the digital operator cable while using MECHATROLINK-III Communications SERVOPACK.

● External Dimensions (Units: mm)

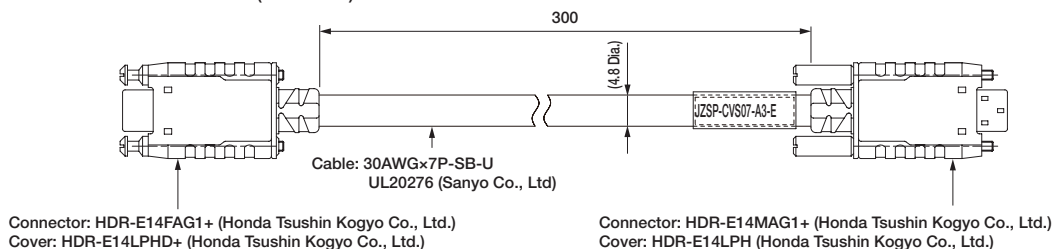



## Selecting Cables

### (7) Connection Cable for Personal Computer for CN7 (Model: JZSP-CVS06-02-E)

- External Dimensions (Units: mm)

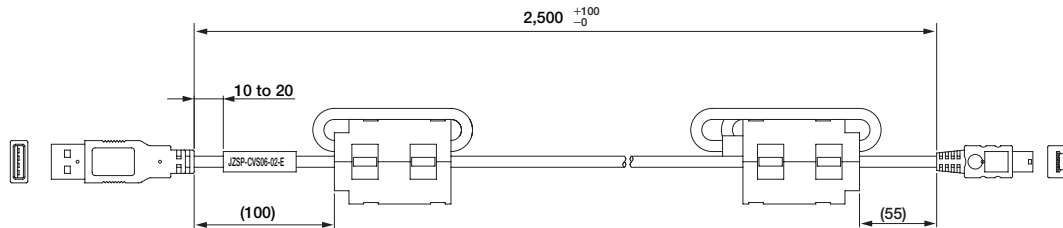

**IMPORTANT** Use a cable specified by Yaskawa.  
When using other cables, operation cannot be guaranteed.

### (8) MECHATROLINK-III Communications Cable for CN6 (Model: JEPMC-W6012--E)

- External Dimensions (Units: mm)

Cables with Connectors at Both Ends

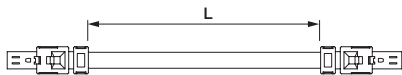

Model	Cable Length (L)
JEPMC-W6012-A2-E	0.2 m
JEPMC-W6012-A5-E	0.5 m
JEPMC-W6012-01-E	1 m
JEPMC-W6012-02-E	2 m
JEPMC-W6012-03-E	3 m
JEPMC-W6012-04-E	4 m
JEPMC-W6012-05-E	5 m
JEPMC-W6012-10-E	10 m
JEPMC-W6012-20-E	20 m
JEPMC-W6012-30-E	30 m
JEPMC-W6012-50-E	50 m

### (9) MECHATROLINK-III Communications Cable for CN6 (Model: JEPMC-W6013--E)

- External Dimensions (Units: mm)

Cables with Connectors at Both Ends (With Ferrite Core)

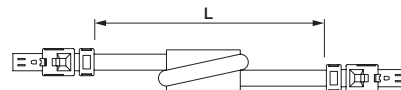

Model	Cable Length (L)
JEPMC-W6013-10-E	10 m
JEPMC-W6013-20-E	20 m
JEPMC-W6013-30-E	30 m
JEPMC-W6013-50-E	50 m
JEPMC-W6013-75-E	75 m

### (10) MECHATROLINK-III Communications Cable for CN6 (Model: JEPMC-W6014-□□-E)

- External Dimensions (Units: mm)

Cable with Loose Wire at One End

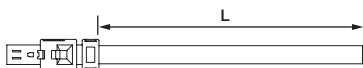

Model	Cable Length (L)
JEPMC-W6014-A5-E	0.5 m
JEPMC-W6014-01-E	1 m
JEPMC-W6014-03-E	3 m
JEPMC-W6014-05-E	5 m
JEPMC-W6014-10-E	10 m
JEPMC-W6014-30-E	30 m
JEPMC-W6014-50-E	50 m

**IMPORTANT** Use a MECHATROLINK-III communications cable specified by Yaskawa. When using other cables, noise resistance may be reduced, and operation cannot be guaranteed.

Selecting Cables

(11) Cable for Analog Monitor for CN5  
(Model: JZSP-CA01-E)

• External Dimensions (Units: mm)

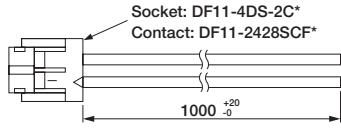

\* : Manufactured by Hirose Electric Corporation.

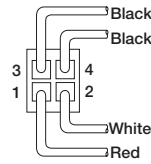

View from Cable End

• Specifications

Pin No.	Cable Color	Signal	Standard Settings
1	Red	Analog Monitor 2	Motor speed : 1V/1000 min-1
2	White	Analog Monitor 1	Torque reference : 1V/100% rated torque
3, 4	Black (2 cables)	GND(0V)	-

Note : The specifications above are factory settings. Monitor specifications can be changed by changing parameters Pn006 and Pn007.

(12) Cable with Connector for CN8  
(Model: JZSP-CVH03-03-E)

• External Dimensions (Units: mm)

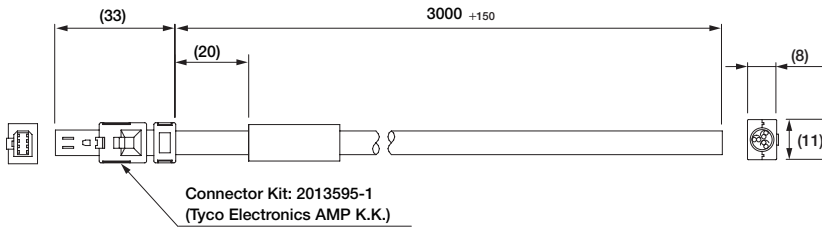

Connector Kit: 2013595-1  
(Tyco Electronics AMP K.K.)

• Specifications

Pin No.	Signal	Lead Color	Marking Color
1	Not used	-	-
2	Not used	-	-
3	/HWBB1-	White	Black
4	/HWBB1+	White	Red
5	/HWBB2-	Gray	Black
6	/HWBB2+	Gray	Red
7	EDM1-	Orange	Black
8	EDM1+	Orange	Red

(Model: JZSP-CVH03-03-E-G3)

• External Dimensions (Units: mm)

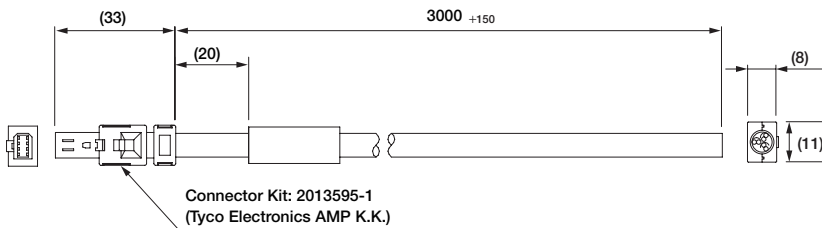

Connector Kit: 2013595-1  
(Tyco Electronics AMP K.K.)

• Specifications

Pin No.	Signal	Lead Color	Marking Color
1	Not used	-	-
2	Not used	-	-
3	/HWBB1-	White	-
4	/HWBB1+	Brown	-
5	/HWBB2-	Green	-
6	/HWBB2+	Yellow	-
7	EDM1-	Grey	-
8	EDM1+	Pink	-