

VARISPEED F7

Vector Control Frequency Inverter

USER'S MANUAL



Table of Content

Warnings	VII
Safety Precautions and Instructions for Use	VIII
EMC Compatibility	X
Line Filters	XII
Registered Trademarks	XV
1 Handling Inverters	1-1
Varispeed F7 Introduction	1-2
◆ Varispeed F7 Applications	1-2
◆ Varispeed F7 Models	1-2
Confirmations upon Delivery	1-4
◆ Checks	1-4
◆ Nameplate Information	1-4
◆ Component Names	1-6
Exterior and Mounting Dimensions	1-8
◆ Open Chassis Inverters (IP00)	1-8
◆ Enclosed Wall-mounted Inverters (NEMA1)	1-9
Checking and Controlling the Installation Site	1-11
◆ Installation Site	1-11
◆ Controlling the Ambient Temperature	1-11
◆ Protecting the Inverter from Foreign Matter	1-11
Installation Orientation and Space	1-12
Removing and Attaching the Terminal Cover	1-13
◆ Removing the Terminal Cover	1-13
◆ Attaching the Terminal Cover	1-13
Removing/Attaching the Digital Operator and Front Cover	1-14
◆ Inverters of 18.5 kW or Less	1-14
◆ Inverters of 22 kW or More	1-17
2 Wiring.....	2-1
Connections to Peripheral Devices	2-2
Connection Diagram	2-3
◆ Circuit Descriptions	2-4
Terminal Block Configuration	2-5
Wiring Main Circuit Terminals	2-6
◆ Applicable Wire Sizes and Closed-loop Connectors	2-6
◆ Main Circuit Terminal Functions	2-11
◆ Main Circuit Configurations	2-12
◆ Standard Connection Diagrams	2-13
◆ Wiring the Main Circuits	2-14
Wiring Control Circuit Terminals	2-20
◆ Wire Sizes	2-20
◆ Control Circuit Terminal Functions	2-22
◆ Control Circuit Terminal Connections	2-25
◆ Control Circuit Wiring Precautions	2-26
Wiring Check	2-27

◆ Checks	2-27
Installing and Wiring Option Cards	2-28
◆ Option Card Models and Specifications	2-28
◆ Installation	2-28
◆ PG Speed Control Card Terminals and Specifications	2-30
◆ PG-X2	2-30
◆ Wiring	2-31
◆ Wiring Terminal Blocks	2-33
3 Digital Operator and Modes	3-1
Digital Operator	3-2
◆ Digital Operator Display	3-2
◆ Digital Operator Keys	3-2
Modes	3-4
◆ Inverter Modes	3-4
◆ Switching Modes	3-5
◆ Drive Mode	3-6
◆ Quick Programming Mode	3-7
◆ Advanced Programming Mode	3-8
◆ Verify Mode	3-10
◆ Autotuning Mode	3-11
4 Trial Operation	4-1
Trial Operation Procedure	4-2
Trial Operation	4-3
◆ Application Confirmation	4-3
◆ Setting the Power Supply Voltage Jumper (400 V Class Inverters of 75 kW or Higher)	4-3
◆ Power ON	4-4
◆ Checking the Display Status	4-4
◆ Basic Settings	4-5
◆ Settings for the Control Methods	4-7
◆ Autotuning	4-8
◆ Application Settings	4-12
◆ No-load Operation	4-12
◆ Loaded Operation	4-12
◆ Check and Recording Parameters	4-13
Adjustment Suggestions	4-14
5 User Parameters	5-1
User Parameter Descriptions	5-2
◆ Description of User Parameter Tables	5-2
Digital Operation Display Functions and Levels	5-3
◆ User Parameters Available in Quick Programming Mode	5-4
User Parameter Tables	5-7
◆ A: Setup Settings	5-7
◆ Application Parameters: b	5-9
◆ Tuning Parameters: C	5-19
◆ Reference Parameters: d	5-25

◆ Motor Parameters: E	5-30
◆ Option Parameters: F	5-35
◆ Terminal Function Parameters: H	5-41
◆ Protection Function Parameters: L	5-50
◆ N: Special Adjustments	5-58
◆ Digital Operator Parameters: o	5-60
◆ U: Monitor Parameters	5-64
◆ Factory Settings that Change with the Control Method (A1-02)	5-70
◆ Factory Settings that Change with the Inverter Capacity (o2-04)	5-72
◆ Parameter Initial Values that Change With the Setting of C6-01	5-74

6 Parameter Settings by Function..... 6-1

Application and Overload Selections	6-2
◆ Select the Overload to Suit the Application	6-2
Frequency Reference	6-7
◆ Selecting the Frequency Reference Source	6-7
◆ Using Multi-Step Speed Operation	6-10
Run Command Input Methods	6-12
◆ Selecting the Run Command Source	6-12
Stopping Methods	6-14
◆ Selecting the Stopping Method when a Stop Command is Input	6-14
◆ Using the DC Injection Brake	6-17
◆ Using an Emergency Stop	6-18
Acceleration and Deceleration Characteristics	6-19
◆ Setting Acceleration and Deceleration Times	6-19
◆ Accelerating and Decelerating Heavy Loads (Dwell Function)	6-22
◆ Preventing the Motor from Stalling During Acceleration (Stall Prevention During Acceleration Function)	6-22
◆ Preventing Overvoltage During Deceleration	6-24
Adjusting Frequency References	6-26
◆ Adjusting Analog Frequency References	6-26
◆ Operation Avoiding Resonance (Jump Frequency Function)	6-28
Speed Limit (Frequency Reference Limits)	6-30
◆ Limiting the Maximum Output Frequency	6-30
◆ Limiting the Minimum Output Frequency	6-30
Frequency Detection	6-31
◆ Speed Agreement Function	6-31
Improving the Operation Performance	6-33
◆ Reducing the Motor Speed Fluctuation (Slip Compensation Function)	6-33
◆ Torque Compensation for Sufficient Torque at Start and Low-speed Operation	6-35
◆ Automatic Speed Regulator (ASR)	6-36
◆ Hunting-Prevention Function	6-41
◆ Stabilizing Speed (Automatic Frequency Regulator)	6-42
Machine Protection	6-43
◆ Limiting Motor Torque (Torque Limit Function)	6-43
◆ Preventing Motor Stalling During Operation	6-45
◆ Motor Torque Detection	6-46
◆ Motor Overload Protection	6-48

◆ Motor Overheating Protection Using PTC Thermistor Inputs	6-50
◆ Limiting Motor Rotation Direction and Output Phase Rotation	6-51
Automatic Restart	6-52
◆ Restarting Automatically After Momentary Power Loss	6-52
◆ Speed Search	6-53
◆ Continuing Operation at Constant Speed when the Frequency Reference is Lost	6-57
◆ Restarting Operation After Transient Error (Auto Restart Function)	6-58
Inverter Protection	6-59
◆ Overheating Protection for an Inverter-Mounted Braking Resistor	6-59
◆ Inverter Overheat Protection	6-60
◆ Input Open Phase Protection	6-60
◆ Output Open Phase Protection	6-61
◆ Ground Fault Protection	6-61
◆ Cooling Fan Control	6-61
◆ Setting the Ambient Temperature	6-62
◆ OL2 Characteristics at Low Speed	6-63
Input Terminal Functions	6-64
◆ Temporarily Switching Operation between Digital Operator and Control Circuit Terminals	6-64
◆ Blocking the Inverter Output (Baseblock Commands)	6-64
◆ OH2 (Overheat) Alarm Signal Input	6-65
◆ Multifunction Analog Input A2 Disable/Enable	6-65
◆ Drive Enable/Disable	6-66
◆ Stopping Acceleration and Deceleration (Acceleration/Deceleration Ramp Hold)	6-66
◆ Raising and Lowering Frequency References Using Contact Signals (UP/DOWN) ...	6-67
◆ Adding/Subtracting a Fixed Speed to an Analog Reference (Trim Control)	6-69
◆ Hold Analog Frequency Using User-set Timing	6-71
◆ Switching Operation Source to Communication Option Card	6-72
◆ Jog Frequency with Direction Commands (FJOG/RJOG)	6-72
◆ Stopping the Inverter on External Device Errors (External Error Function)	6-73
Output Terminal Functions	6-74
Monitor Parameters	6-77
◆ Using the Analog Monitor Outputs	6-77
◆ Using the Pulse Train Monitor Output	6-78
Individual Functions	6-80
◆ Using MEMOBUS Communications	6-80
◆ Using the Timer Function	6-95
◆ Using PID Control	6-96
◆ Energy-saving	6-106
◆ Field Weakening	6-107
◆ Field Forcing	6-108
◆ Setting Motor 1 Parameters	6-108
◆ Setting the V/f Pattern 1	6-110
◆ Setting Motor 2 Parameters	6-116
◆ Setting the V/f Pattern 2	6-117
◆ Torque Control	6-118
◆ Droop Control Function	6-124
◆ Zero-Servo Function	6-125
◆ Kinetic Energy Buffering	6-127
◆ High Slip Braking (HSB)	6-128
Digital Operator Functions	6-130

◆	Setting Digital Operator Functions	6-130
◆	Copying Parameters	6-132
◆	Prohibiting Overwriting of Parameters	6-136
◆	Setting a Password	6-136
◆	Displaying User-set Parameters Only	6-137
Option Cards		6-138
◆	Using PG Feedback Option Cards	6-138
◆	Analog Reference Cards	6-141
◆	Digital Reference Cards	6-141
7	Troubleshooting	7-1
Protective and Diagnostic Functions		7-2
◆	Fault Detection	7-2
◆	Alarm Detection	7-9
◆	Operator Programming Errors	7-12
◆	Auto-tuning Fault	7-14
◆	Digital Operator Copy Function Faults	7-15
Troubleshooting		7-17
◆	If A Parameter Cannot Be Set	7-17
◆	If the Motor Does Not Operate Properly	7-18
◆	If the Direction of the Motor Rotation is Reversed	7-19
◆	If the Motor Stalls or Acceleration is Slow	7-19
◆	If the Motor Operates at Higher Speed than the Frequency Reference	7-20
◆	If There is Low Speed Control Accuracy Above Base Speed in Open Loop Vector Control Mode	7-20
◆	If Motor Deceleration is Slow	7-20
◆	If the Motor Overheats	7-21
◆	If Peripheral Devices Like PLCs or Others are Influenced by the Starting or Running Inverter	7-21
◆	If the Earth Leakage Breaker Operates When the Inverter is Running	7-21
◆	If There is Mechanical Oscillation	7-22
◆	If the Motor Rotates Even When Inverter Output is Stopped	7-23
◆	If Output Frequency Does Not Rise to Frequency Reference	7-23
8	Maintenance and Inspection.....	8-1
Maintenance and Inspection		8-2
◆	Periodic Inspection	8-2
◆	Periodic Maintenance of Parts	8-3
◆	Cooling Fan Replacement	8-4
◆	Removing and Mounting the Terminal Card	8-6
9	Specifications	9-1
Standard Inverter Specifications		9-2
◆	Specifications by Model	9-2
◆	Common Specifications	9-4

10	Appendix	10-1
	Inverter Application Precautions	10-2
	◆ Selection	10-2
	◆ Installation	10-3
	◆ Settings	10-3
	◆ Handling	10-4
	Motor Application Precautions	10-5
	◆ Using the Inverter for an Existing Standard Motor	10-5
	◆ Using the Inverter for Special Motors	10-5
	◆ Power Transmission Mechanism (Speed Reducers, Belts and Chains)	10-6
	User Constants	10-7

Warnings



CAUTION

Cables must not be connected or disconnected, nor signal tests carried out, while the power is switched on.

The Varispeed F7 DC bus capacitor remains charged even after the power has been switched off. To avoid an electric shock hazard, disconnect the frequency inverter from the mains before carrying out maintenance. Then wait for at least 5 minutes after all LEDs have gone out.

Do not perform a withstand voltage test on any part of the inverter. It contains semiconductors, which are not designed for such high voltages.

Do not remove the digital operator while the mains supply is switched on. The printed circuit board must also not be touched while the inverter is connected to the power.

Never connect general LC/RC interference suppression filters, capacitors or overvoltage protection devices to the inverter input or output.

To avoid unnecessary overcurrent faults, etc. being displayed, the signaling contacts of any contactor or switch fitted between inverter and motor must be integrated into the inverter control logic (e.g. baseblock).

This is absolutely imperative!

This manual must be read thoroughly before connecting and operating the inverter. All safety precautions and instructions for use must be followed.

The inverter must be operated with the appropriate line filters, following the installation instructions in this manual and with all covers closed and terminals covered.

Only then will adequate protection be provided. Please do not connect or operate any equipment with visible damage or missing parts. The operating company is responsible for any injuries or equipment damage resulting from failure to heed the warnings in this manual.

Safety Precautions and Instructions for Use

■ General

Please read these safety precautions and instructions for use thoroughly before installing and operating this inverter. Also read all of the warning signs on the inverter and ensure they are never damaged or removed.

Live and hot inverter components may be accessible during operation. Removal of housing components, the digital operator or terminal covers runs the risk of serious injuries or damage in the event of incorrect installation or operation. The fact that frequency inverters control rotating mechanical machine components can give rise to other dangers.

The instructions in this manual must be followed. Installation, operation and maintenance may only be carried out by qualified personnel. For the purposes of the safety precautions, qualified personnel are defined as individuals who are familiar with the installation, starting, operation and maintenance of frequency inverters and have the proper qualifications for this work. Safe operation of these units is only possible if they are used properly for their intended purpose.

The DC bus capacitors can remain live for about 5 minutes after the inverter is disconnected from the power. It is therefore necessary to wait for this time before opening its covers. All of the main circuit terminals may still carry dangerous voltages.

Children and other unauthorized persons must not be allowed access to these inverters.

Keep these Safety Precautions and Instructions for Use readily accessible and supply them to all persons with any form of access to the inverters.

■ Intended Use

Frequency inverters are intended for installation in electrical systems or machinery.

Their installation in machinery and systems must conform to the following product standards of the Low Voltage Directive:

EN 50178, 1997-10, Equipping of Power Systems with Electronic Devices

EN 60204-1, 1997-12, Machine Safety and Equipping with Electrical Devices

Part 1: General Requirements (IEC 60204-1:1997)/

Please note: Includes Corrigendum of September 1998

EN 61010-1, A2, 1995, Safety Requirements for Information Technology Equipment

(IEC 950, 1991 + A1, 1992 + A2, 1993 + A3, 1995 + A4, 1996, modified)

CE marking is carried out to EN 50178, using the line filters specified in this manual and following the appropriate installation instructions.

■ Transportation and storage

The instructions for transportation, storage and proper handling must be followed in accordance with the technical data.

■ Installation

Install and cool the inverters as specified in the documentation. The cooling air must flow in the specified direction. The inverter may therefore only be operated in the specified position (e.g. upright). Maintain the specified clearances. Protect the inverters against impermissible loads. Components must not be bent nor insulation clearances changed. To avoid damage being caused by static electricity, do not touch any electronic components or contacts.

■ Electrical Connection

Carry out any work on live equipment in compliance with the national safety and accident prevention regulations. Carry out electrical installation in compliance with the relevant regulations. In particular, follow the installation instructions ensuring electromagnetic compatibility (EMC), e.g. shielding, grounding, filter arrangement and laying of cables. This also applies to equipment with the CE mark. It is the responsibility of the manufacturer of the system or machine to ensure conformity with EMC limits.

Your supplier or OYMC representative must be contacted when using leakage current circuit breaker in conjunction with frequency inverters.

In certain systems it may be necessary to use additional monitoring and safety devices in compliance with the relevant safety and accident prevention regulations. The frequency inverter hardware must not be modified.

■ Notes

The VARISPEED F7 frequency inverters are certified to CE, UL, and c-UL.

EMC Compatibility

■ Introduction

This manual was compiled to help system manufacturers using YASKAWA frequency inverters to design and install electrical switch gear. It also describes the measures necessary to comply with the EMC Directive. The manual's installation and wiring instructions must therefore be followed.

Our products are tested by authorized bodies using the standards listed below.

Product standard: EN 61800-3:1996

EN 61800-3; A11:2000

■ Measures to Ensure Conformity of YASKAWA Frequency inverters to the EMC Directive

YASKAWA frequency inverters do not necessarily have to be installed in a switch cabinet.

It is not possible to give detailed instructions for all of the possible types of installation. This manual therefore has to be limited to general guidelines.

All electrical equipment produces radio and line-borne interference at various frequencies. The cables pass this on to the environment like an aerial.

Connecting an item of electrical equipment (e.g. drive) to a supply without a line filter can therefore allow HF or LF interference to get into the mains.

The basic countermeasures are isolation of the wiring of control and power components, proper grounding and shielding of cables.

A large contact area is necessary for low-impedance grounding of HF interference. The use of grounding straps instead of cables is therefore definitely advisable.

Moreover, cable shields must be connected with purpose-made ground clips.

■ Laying Cables

Measures Against Line-Borne Interference:

Line filter and frequency inverter must be mounted on the same metal plate. Mount the two components as close to each other as possible, with cables kept as short as possible.

Use a power cable with well-grounded shield. Use a shielded motor cable not exceeding 20 meters in length. Arrange all grounds so as to maximize the area of the end of the lead in contact with the ground terminal (e.g. metal plate).

Shielded Cable:

- –Use a cable with braided shield.
- –Ground the maximum possible area of the shield. It is advisable to ground the shield by connecting the cable to the ground plate with metal clips (see following figure).

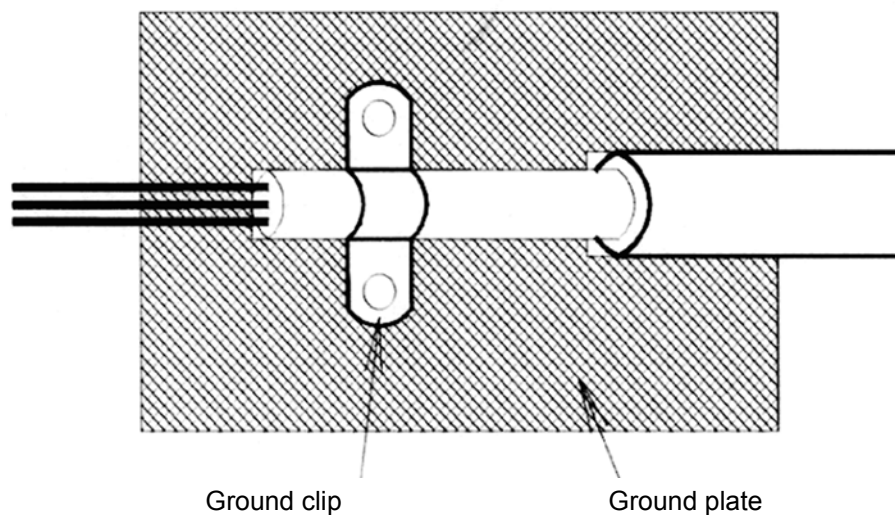

The grounding surfaces must be highly conductive bare metal. Remove any coats of varnish and paint.

- –Ground the cable shields at both ends.
- –Ground the motor of the machine.

Refer to the document EZZ006543 “Making Yaskawa Inverter Products Conform with the EMC Directive”. Please contact Omron Yaskawa Motion Control to get this document.

Line Filters

■ Recommended Line Filters for Varispeed F7

Inverter Model	Line Filter				
Varispeed F7	Model	EN 55011 Class*	Current (A)	Weight (kg)	Dimensions W x D x H
CIMR-F7Z40P4	3G3RV-PFI3010-SE	B, 25 m*	10	1.1	141 x 46 x 330
CIMR-F7Z40P7		B, 25 m*			
CIMR-F7Z41P5		B, 25 m*			
CIMR-F7Z42P2		B, 25 m*			
CIMR-F7Z43P7	3G3RV-PFI3018-SE	B, 25 m*	18	1.3	141 x 46 x 330
CIMR-F7Z44P0		B, 25 m*			
CIMR-F7Z45P5		B, 25 m*			
CIMR-F7Z47P5	3G3RV-PFI3035-SE	B, 25 m*	35	2.1	206 x 50 x 355
CIMR-F7Z4011		B, 25 m*			
CIMR-F7Z4015	3G3RV-PFI3060-SE	B, 25 m*	60	4.0	236 x 65 x 408
CIMR-F7Z4018		B, 25 m*			
CIMR-F7Z4022	3G3RV-PFI3070-SE	A, 100 m	70	3.4	80 x 185 x 329
CIMR-F7Z4030		A, 100 m			
CIMR-F7Z4037	3G3RV-PFI3130-SE	A, 100 m	130	4.7	90 x 180 x 366
CIMR-F7Z4045		A, 100 m			
CIMR-F7Z4055		A, 100 m			
CIMR-F7Z4075	3G3RV-PFI3170-SE	A, 100 m	170	6.0	120 x 170 x 451
CIMR-F7Z4090	3G3RV-PFI3200-SE	A, 100 m	250	11	130 x 240 x 610
CIMR-F7Z4110		A, 100 m			
CIMR-F7Z4132	3G3RV-PFI3400-SE	A, 100 m	400	18.5	300 x 160 x 610
CIMR-F7Z4160		A, 100 m			
CIMR-F7Z4185	3G3RV-PFI3600-SE	A, 100 m	600	11,0	260 x 135 x 386
CIMR-F7Z4220		A, 100 m			
CIMR-F7Z4300	3G3RV-PFI3800-SE	A, 100 m	800	31.0	300 x 160 x 716

* Class A, 100 m

Permissible emission of power drive systems for commercial and light environment (EN61800-3, A11)
(general availability, 1st environment)

Inverter Model	Line Filters				
	Varispeed F7	Type	EN 55011 Class	Current (A)	Weight (kg)
CIMR-F7Z20P4	3G3RV-PFI3010-SE	B, 25 m*	10	1.1	141 x 45 x 330
CIMR-F7Z20P7		B, 25 m*			
CIMR-F7Z21P5		B, 25 m*			
CIMR-F7Z22P2	3G3RV-PFI3018-SE	B, 25 m*	18	1.3	141 x 46 x 330
CIMR-F7Z23P7	3G3RV-PFI2035-SE	B, 25 m*	35	1.4	141 x 46 x 330
CIMR-F7Z25P5		B, 25 m*			
CIMR-F7Z27P5	3G3RV-PFI2060-SE	B, 25 m*	60	3	206 x 60 x 355
CIMR-F7Z2011		B, 25 m*			
CIMR-F7Z2015	3G3RV-PFI2100-SE	B, 25 m*	100	4.9	236 x 80 x 408
CIMR-F7Z2018		B, 25 m*			
CIMR-F7Z2022	3G3RV-PFI2130-SE	A, 100 m	130	4.3	90 x 180 x 366
CIMR-F7Z2030		A, 100 m			
CIMR-F7Z2037	3G3RV-PFI2160-SE	A, 100 m	160	6.0	120 x 170 x 451
CIMR-F7Z2045	3G3RV-PFI2200-SE	A, 100 m	200	11.0	130 x 240 x 610
CIMR-F7Z2055		A, 100 m			
CIMR-F7Z2075	3G3RV-PFI3400-SE	A, 100 m	400	18.5	300 x 160 x 564
CIMR-F7Z2090		A, 100 m			
CIMR-F7Z2110	3G3RV-PFI3600-SE	A, 100 m	600	11.0	260 x 135 x 386

* Class A, 100 m

■ Installation of Inverters and EMC filters

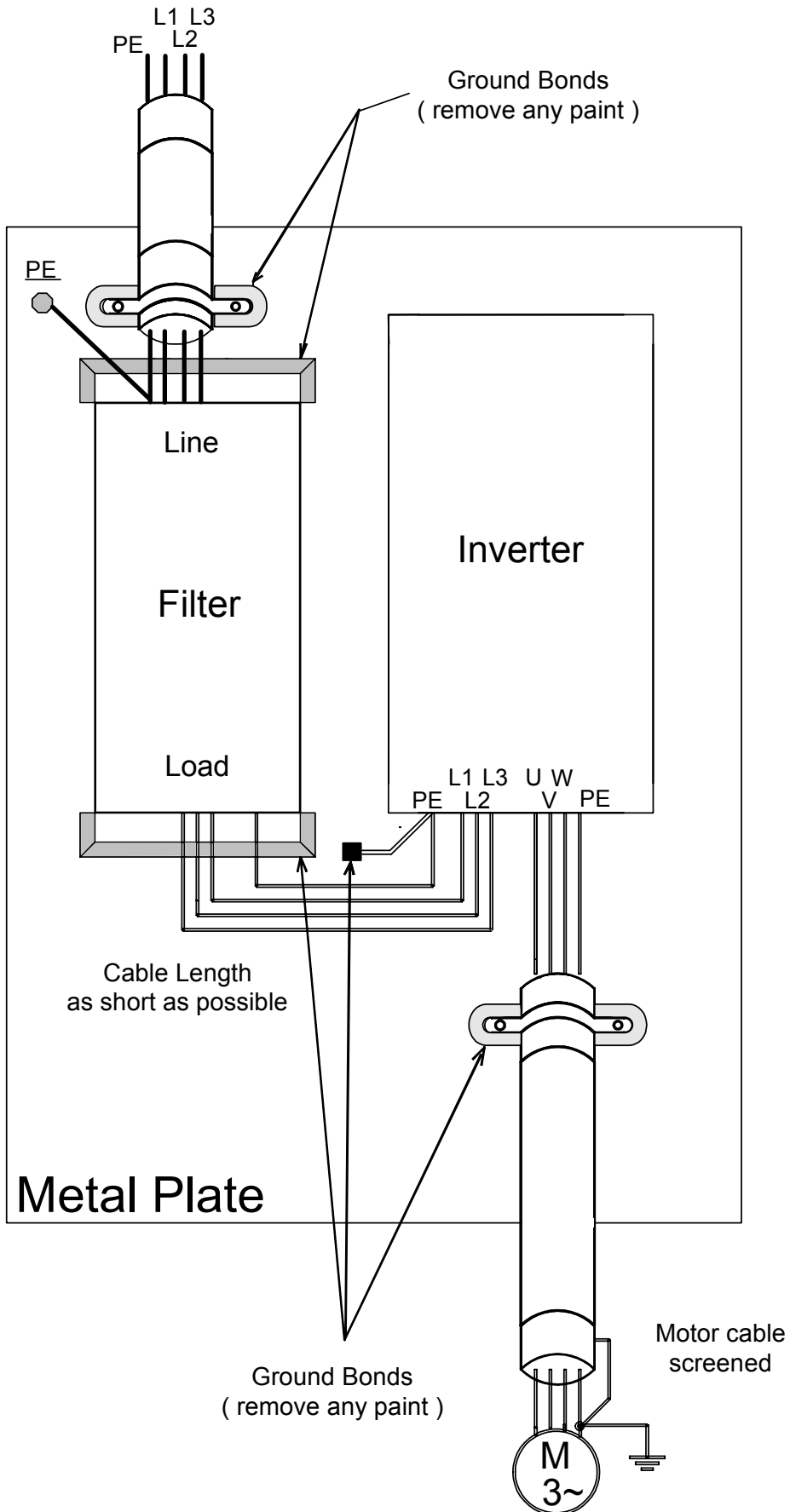

Registered Trademarks

The following registered trademarks are used in this manual.

- DeviceNet is a registered trademark of the ODVA (Open DeviceNet Vendors Association, Inc.).
- InterBus is a registered trademark of Phoenix Contact Co.
- Profibus is a registered trademark of Siemens AG.



1

Handling Inverters

This chapter describes the checks required upon receiving or installing an Inverter.

Varispeed F7 Introduction.....	1-2
Confirmations upon Delivery.....	1-4
Exterior and Mounting Dimensions.....	1-8
Checking and Controlling the Installation Site.....	1-11
Installation Orientation and Space.....	1-12
Removing and Attaching the Terminal Cover.....	1-13
Removing/Attaching the Digital Operator and Front Cover..	1-14

Varispeed F7 Introduction

◆ Varispeed F7 Applications

The Varispeed F7 is ideal for the following applications.

- Fan, blower, and pump applications
- Conveyors, pushers, metal tooling machines, etc.

Settings must be adjusted to the application for optimum operation. Refer to [Chapter 4 Trial Operation](#)

◆ Varispeed F7 Models

The Varispeed F7 Series includes Inverters in two voltage classes: 200 V and 400 V. The maximum motor capacities vary from 0.55 to 300 kW (42 models).

Table 1.1 Varispeed F7 Models

Voltage Class	Maximum Motor Capacity kW	Varispeed F7		Specifications (Always specify through the protective structure when ordering.)	
		Output Capacity kVA	Basic Model Number	Open Chassis (IEC IP00) CIMR-F7Z□□□□□□□□	Enclosed Wall-mounted (IEC IP20, NEMA 1) CIMR-F7Z□□□□□□□□
200 V class	0.55	1.2	CIMR-F7Z20P4	Remove the top and bottom covers from the Enclosed Wall-mounted model.	20P41□
	0.75	1.6	CIMR-F7Z20P7		20P71□
	1.5	2.7	CIMR-F7Z21P5		21P51□
	2.2	3.7	CIMR-F7Z22P2		22P21□
	3.7	5.7	CIMR-F7Z23P7		23P71□
	5.5	8.8	CIMR-F7Z25P5		25P51□
	7.5	12	CIMR-F7Z27P5		27P51□
	11	17	CIMR-F7Z2011		20111□
	15	22	CIMR-F7Z2015		20151□
	18.5	27	CIMR-F7Z2018		20181□
	22	32	CIMR-F7Z2022	20220□	20221□
	30	44	CIMR-F7Z2030	20300□	20301□
	37	55	CIMR-F7Z2037	20370□	20371□
	45	69	CIMR-F7Z2045	20450□	20451□
	55	82	CIMR-F7Z2055	20550□	20551□
	75	110	CIMR-F7Z2075	20750□	20751□
90	130	CIMR-F7Z2090	20900□	–	
110	160	CIMR-F7Z2110	21100□	–	

Voltage Class	Maximum Motor Capacity kW	Varispeed F7		Specifications (Always specify through the protective structure when ordering.)	
		Output Capacity kVA	Basic Model Number	Open Chassis (IEC IP00) CIMR-F7Z□□□□□□□□	Enclosed Wall-mounted (IEC IP20, NEMA 1) CIMR-F7Z□□□□□□□□
400 V class	0.55	1.4	CIMR-F7Z40P4	Remove the top and bottom covers from the Enclosed Wall-mount model.	40P41□
	0.75	1.6	CIMR-F7Z40P7		40P71□
	1.5	2.8	CIMR-F7Z41P5		41P51□
	2.2	4.0	CIMR-F7Z42P2		42P21□
	3.7	5.8	CIMR-F7Z43P7		43P71□
	4.0	6.6	CIMR-F7Z44P0		44P01
	5.5	9.5	CIMR-F7Z45P5		45P51□
	7.5	13	CIMR-F7Z47P5		47P51□
	11	18	CIMR-F7Z4011		40111□
	15	24	CIMR-F7Z4015		40151□
	18.5	30	CIMR-F7Z4018		40181□
	22	34	CIMR-F7Z4022	40220□	40221□
	30	46	CIMR-F7Z4030	40300□	40301□
	37	57	CIMR-F7Z4037	40370□	40371□
	45	69	CIMR-F7Z4045	40450□	40451□
	55	85	CIMR-F7Z4055	40550□	40551□
	75	110	CIMR-F7Z4075	40750□	40751□
	90	140	CIMR-F7Z4090	40900□	40901□
	110	160	CIMR-F7Z4110	41100□	41101□
	132	200	CIMR-F7Z4132	41320□	41321□
160	230	CIMR-F7Z4160	41600□	41601□	
185	280	CIMR-F7Z4185	41850□	–	
220	390	CIMR-F7Z4220	42200□	–	
300	510	CIMR-F7Z4300	43000□	–	

Confirmations upon Delivery

◆ Checks

Check the following items as soon as the Inverter is delivered.

Item	Method
Has the correct model of Inverter been delivered?	Check the model number on the nameplate on the side of the Inverter.
Is the Inverter damaged in any way?	Inspect the entire exterior of the Inverter to see if there are any scratches or other damage resulting from shipping.
Are any screws or other components loose?	Use a screwdriver or other tools to check for tightness.

If you find any irregularities in the above items, contact the agency from which you purchased the Inverter or your OYMC representative immediately.

◆ Nameplate Information

There is a nameplate attached to the side of each Inverter. The nameplate shows the model number, specifications, lot number, serial number, and other information on the Inverter.

■ Example Nameplate

The following nameplate is an example for a standard domestic European Inverter: 3-phase, 400 VAC, 0.55 kW, IEC IP20 and NEMA 1 standards

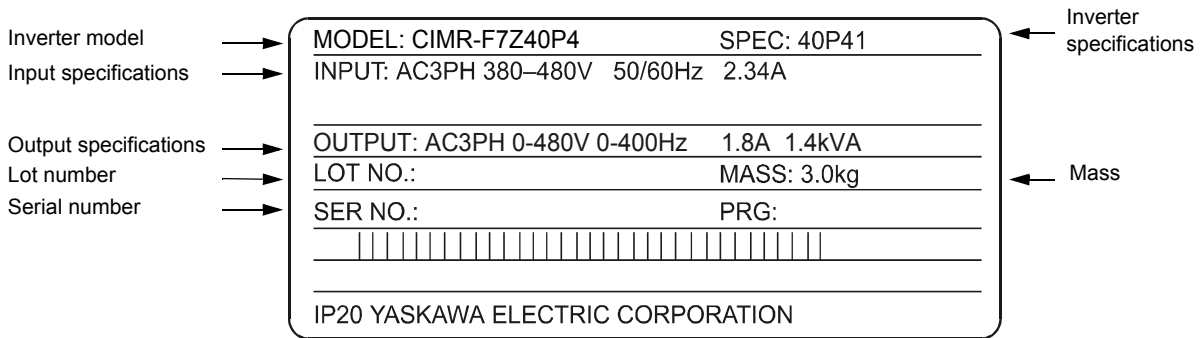

Fig 1.1 Nameplate

■ Inverter Model Numbers

The model number of the Inverter on the nameplate indicates the specification, voltage class, and maximum motor capacity of the Inverter in alphanumeric codes.

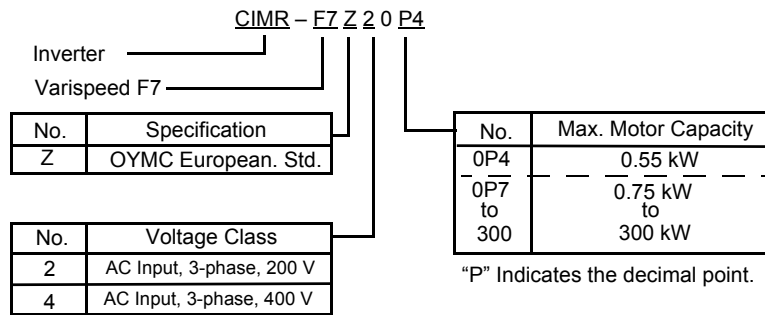

Fig 1.2 Inverter Model Numbers

■ Inverter Specifications

The Inverter specifications ("SPEC") on the nameplate indicate the voltage class, maximum motor capacity, the protective structure, and the revision of the Inverter in alphanumeric codes.

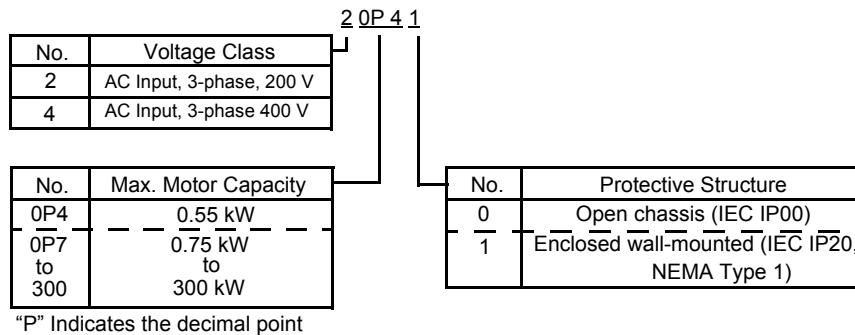

Fig 1.3 Inverter Specifications

◆ Component Names

■ Inverters of 18.5 kW or Less

The external appearance and component names of the Inverter are shown in *Fig 1.4*. The Inverter with the terminal cover removed is shown in *Fig 1.5*.

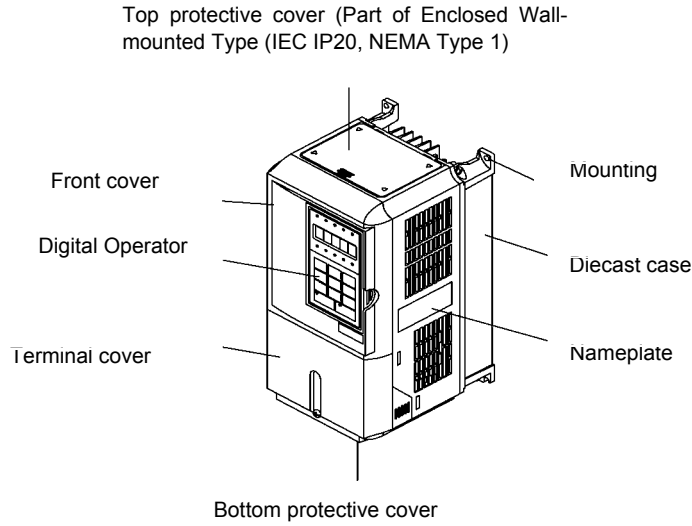

Fig 1.4 Inverter Appearance (18.5 kW or Less)

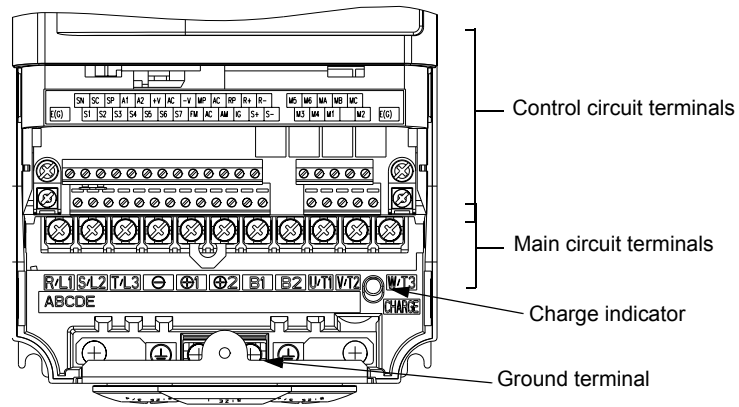

Fig 1.5 Terminal Arrangement (18.5 kW or Less)

■ Inverters of 22 kW or More

The external appearance and component names of the Inverter are shown in *Fig 1.6*. The Inverter with the terminal cover removed is shown in *Fig 1.7*

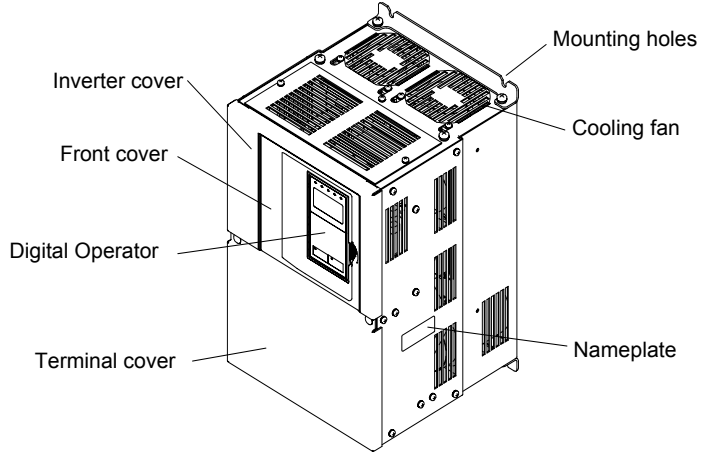

Fig 1.6 Inverter Appearance (22 kW or More)

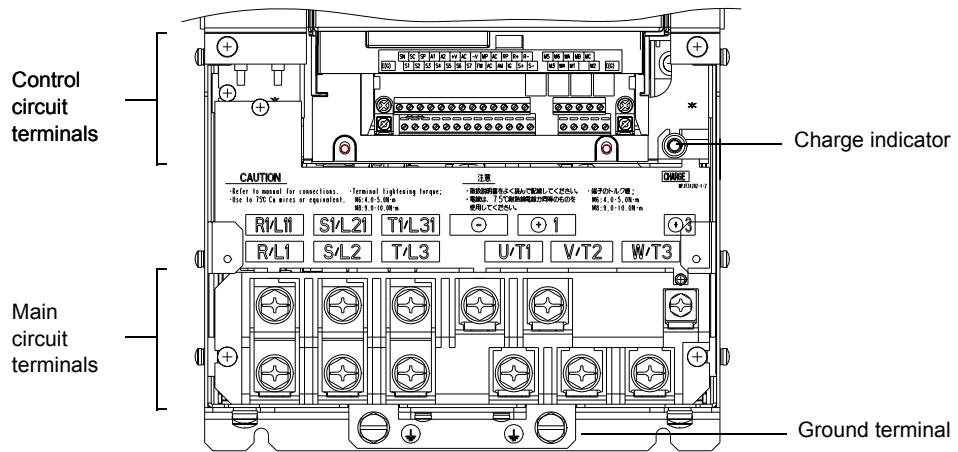
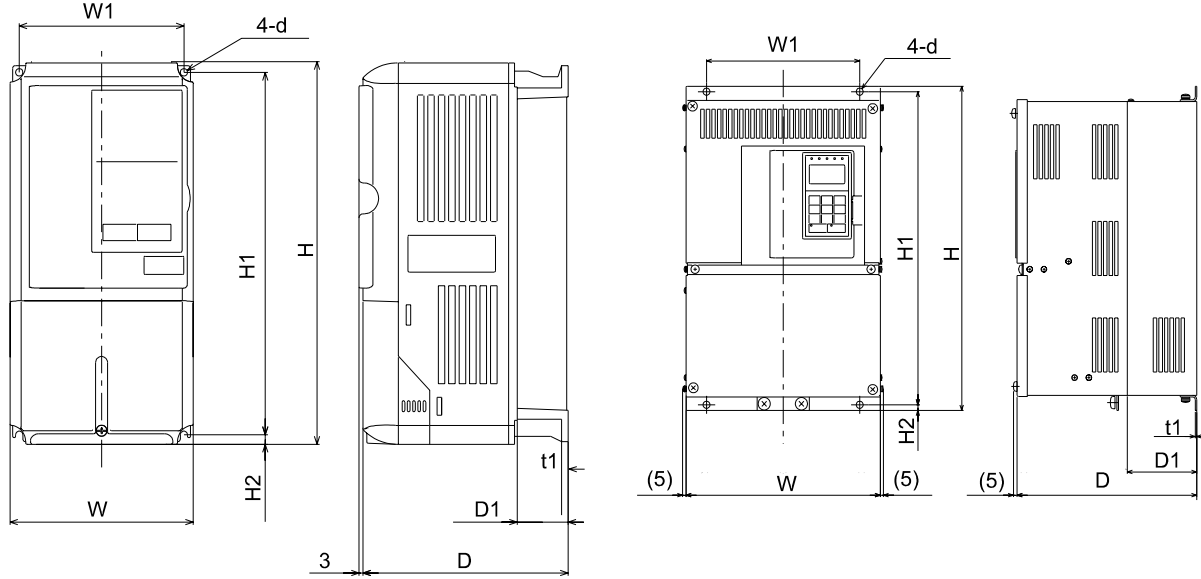

Fig 1.7 Terminal Arrangement (22 kW or More)

Exterior and Mounting Dimensions

◆ Open Chassis Inverters (IP00)

Exterior diagrams of the Open Chassis Inverters are shown below.



200 V/400 V Class Inverters of 0.55 to 18.5 kW

200 V Class Inverters of 22 or 110 kW
400 V Class Inverters of 22 to 160 kW

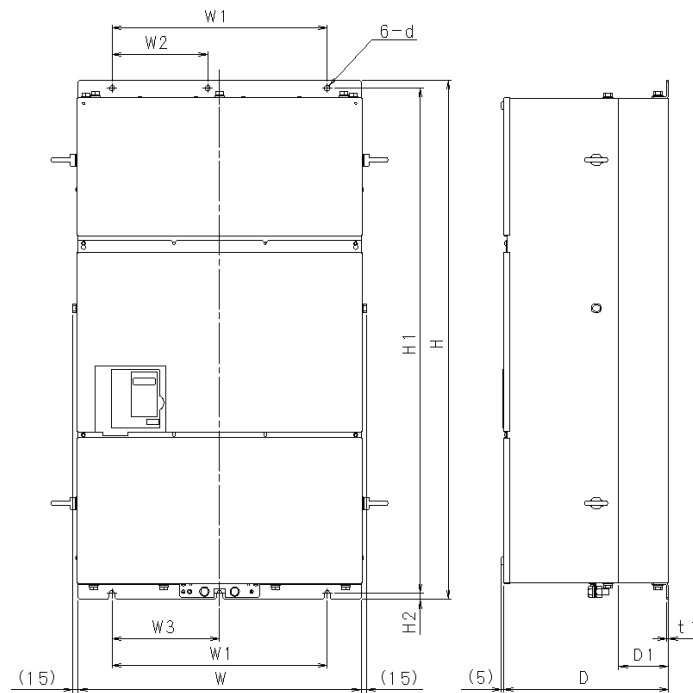

400 V Class Inverters of 185 to 300 kW

Fig 1.8 Exterior Diagrams of Open Chassis Inverters

◆ Enclosed Wall-mounted Inverters (NEMA1)

Exterior diagrams of the Enclosed Wall-mounted Inverters (NEMA1) are shown below.

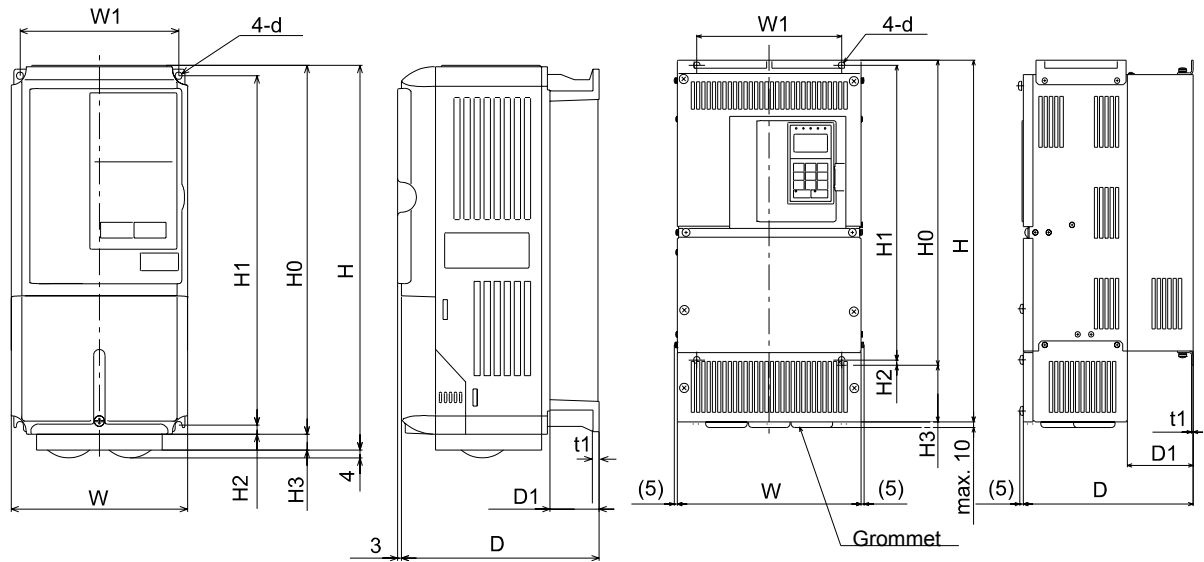

200 V/400 V Class Inverters of 0.55 to 18.5 kW

200 V Class Inverters of 22 or 75 kW
400 V Class Inverters of 22 to 160 kW

Fig 1.9 Exterior Diagrams of Enclosed Wall-mounted Inverters

Table 1.2 Inverter Dimensions (mm) and Masses (kg) of F7 inverters from 0.4 to 160kW

Voltage Class	Max. Applicable Motor Output [kW]	Dimensions (mm)																				Caloric Value (W)			Cooling Method				
		Open Chassis (IP00)										Enclosed Wall-mounted (NEMA1)										External	Internal	Total Heat Generation					
		W	H	D	W1	H1	H2	D1	t1	App- rox Mass	W	H	D	W1	H0	H1	H2	H3	D1	t1	App- rox. Mass					Moun- ting Holes d*			
200 V (3-phase)	0.55	140	280	157	126	266	7	39	5	3	140	280	157	126	280	266	7	0	39	5	3	M5	20	39	59	Natural			
	0.75																						27	42	69				
	1.5																						50	50	100				
	2.2			70				59		129																			
	3.7			112				74		186																			
	5.5			164				84		248																			
	7.5	200	300	197	186	285	7.5	78	2.3	11	240	350	380	207	216	350	335	7.5	0	78	2.3	11	M6	219	113		332	Fan	
	11																							374	170		544		
	15	240	350	207	216	335	7.5	100	2.3	21	250	535	258	195	400	385	7.5	135	100	24	27	M10	429	183	612				
	18.5																						501	211	712				
	22	250	400	258	195	385	7.5	130	4.5	21	250	535	258	195	400	385	7.5	135	100	24	27	M10	586	274	860				
	30																						865	352	1217				
	37	375	600	300	250	575	13	100	3.2	57	380	890	300	250	600	575	13	210	100	62	68	94	95	M12	1015		411		1426
	45																								1266		505		1771
	55	450	725	350	325	700	15	140	4.5	86	455	110	350	325	725	700	13	305	130	3.2	94	95	M12	1588	619		2207		
	75																							2019	838		2857		
90	500	850	360	378	820	15	140	4.5	108	---										100	62	68	94	95	M12	2437	997		3434
110	575	885	380	445	855	15	140	4.5	150	---										150	62	68	94	95	M12	2733	1242		3975
400 V (3-phase)	0.55	140	280	157	126	266	7	39	5	3	140	280	157	126	280	266	7	0	39	5	3	M5	14	39	53	Natural			
	0.75																						17	41	58				
	1.5																						36	48	84				
	2.2			59				56		115																			
	3.7			80				68		148																			
	4.0			70				91		161																			
	5.5	127	82	209																									
	7.5	200	300	197	186	285	7.5	78	2.3	10	240	350	207	216	350	335	7.5	85	100	2.3	24	M6	193	114	307		Fan		
	11																						252	158	410				
	15	240	350	207	216	335	7.5	100	2.3	21	275	535	258	220	450	435	7.5	165	105	40	M10	326	172	498					
	18.5																					426	208	634					
	22	275	450	258	220	435	7.5	130	4.5	21	275	535	258	220	450	435	7.5	165	105	40	M10	466	259	725					
	30																					678	317	995					
	37	325	550	283	260	535	105	105	3.2	36	325	715	283	260	550	535	105	165	105	40	M10	784	360	1144					
	45																					901	415	1316					
	55	450	725	350	325	700	13	130	3.2	88	455	110	350	325	725	700	13	305	130	3.2	96	97	M12	1203	495			1698	
75	1399																							575	1974				
90	500	850	360	370	820	14	140	4.5	89	505	124	360	370	850	820	15	395	130	4.5	122	130	M12	1614	671	2285				
110	500	850	360	370	820	14	140	4.5	102	505	124	360	370	850	820	15	395	130	4.5	130	M12	2097	853	2950					
132																						2388	1002	3390					
160	575	916	378	445	855	46	140	4.5	160	579	132	378	445	916	855	46	408	140	4.5	170	M12	2791	1147	3938					

* Same for Open Chassis and Enclosed Wall-mounted Inverters

Table 1.3 Inverter Dimensions (mm) and Masses (kg) of 400V Class Inverters of 185 kW to 300 kW

Voltage Class	Max. Applicable Motor Output [kW]	Dimensions (mm)											Caloric Value (W)			Cooling Method		
		Open Chassis (IP00)											External	Internal	Total Heat Generation			
W	H	D	W1	W2	W3	H1	H2	D1	t1	App- rox. Mass	Moun- ting Holes d							
400V (3-phase)	185	710	1305	413	540	240	270	1270	15	125.5	4.5	260	M12	3237	1372	4609	Fan	
	220																	280
	300																	

Checking and Controlling the Installation Site

Install the Inverter in the installation site described below and maintain optimum conditions.

◆ Installation Site

Install the Inverter under the following conditions in a pollution degree 2 environment.

Type	Ambient Operating Temperature	Humidity
Enclosed wall-mounted	-10 to + 40 °C	95% RH or less (no condensation)
Open chassis	-10 to + 45 °C	95% RH or less (no condensation)

Protection covers are attached to the top and bottom of the Inverter. Be sure to remove the protection covers before installing a 200 or 400 V Class Inverter with an output of 18.5 kW or less in a panel.

Observe the following precautions when mounting the Inverter.

- Install the Inverter in a clean location which is free from oil mist and dust. It can be installed in a totally enclosed panel that is completely shielded from floating dust.
- When installing or operating the Inverter, always take special care so that metal powder, oil, water, or other foreign matter does not get into the Inverter.
- Do not install the Inverter on combustible material, such as wood.
- Install the Inverter in a location free from radioactive materials and combustible materials.
- Install the Inverter in a location free from harmful gasses and liquids.
- Install the Inverter in a location without excessive oscillation.
- Install the Inverter in a location free from chlorides.
- Install the Inverter in a location not in direct sunlight.

◆ Controlling the Ambient Temperature

To enhance the reliability of operation, the Inverter should be installed in an environment free from extreme temperature increases. If the Inverter is installed in an enclosed environment, such as a box, use a cooling fan or air conditioner to maintain the internal air temperature below 45°C.

◆ Protecting the Inverter from Foreign Matter

Place a cover over the Inverter during installation to shield it from metal powder produced by drilling.

Always remove the cover from the Inverter after completing installation. Otherwise, ventilation will be reduced, causing the Inverter to overheat.

Installation Orientation and Space

Install the Inverter vertically so as not to reduce the cooling effect. When installing the Inverter, always provide the following installation space to allow normal heat dissipation.

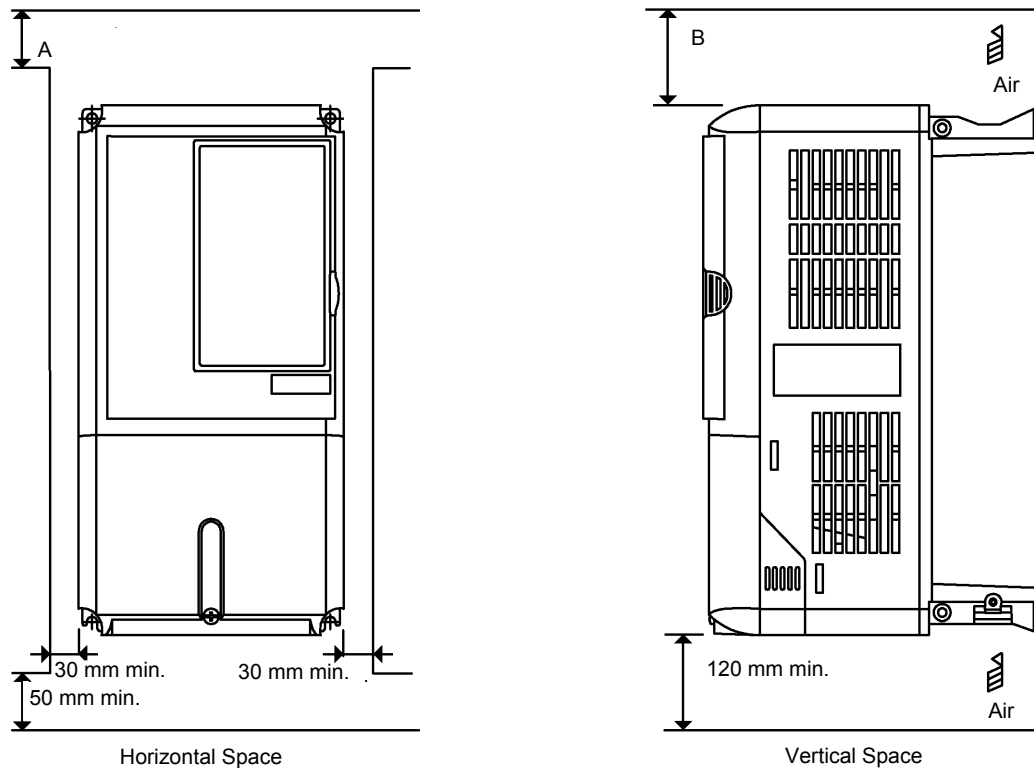

	A	B
200V class inverter, 0.55 to 90 kW 400V class inverter, 0.55 to 132 kW	50 mm	120 mm
200V class inverter, 110 kW 400V class inverter, 160 to 220 kW	120 mm	120 mm
400V class inverter, 300 kW	300 mm	300 mm

Fig 1.10 Inverter Installation Orientation and Space



1. The same space is required horizontally and vertically for both Open Chassis (IP00) and Enclosed Wall-mounted (IP20, NEMA 1) Inverters.
2. Always remove the protection covers before installing a 200 or 400 V Class Inverter with an output of 18.5 kW or less in a panel.
Always provide enough space for suspension eye bolts and the main circuit lines when installing a 200 or 400 V Class Inverter with an output of 22 kW or more in a panel.

Removing and Attaching the Terminal Cover

Remove the terminal cover to wire cables to the control circuit and main circuit terminals.

◆ Removing the Terminal Cover

■ Inverters of 18.5 kW or Less

Loosen the screw at the bottom of the terminal cover, press in on the sides of the terminal cover in the directions of arrows 1, and then lift up on the terminal in the direction of arrow 2.

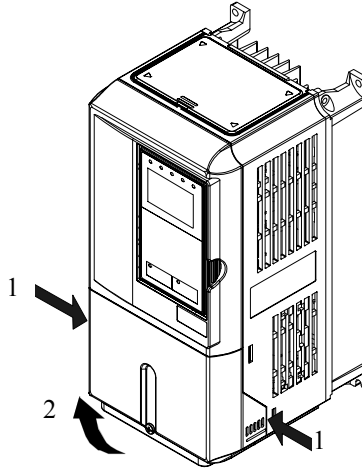

Fig 1.11 Removing the Terminal Cover (Model CIMR-F7Z25P5 Shown Above)

■ Inverters of 22 kW or More

Loosen the screws on the left and right at the top of the terminal cover, pull out the terminal cover in the direction of arrow 1 and then lift up on the terminal in the direction of arrow 2.

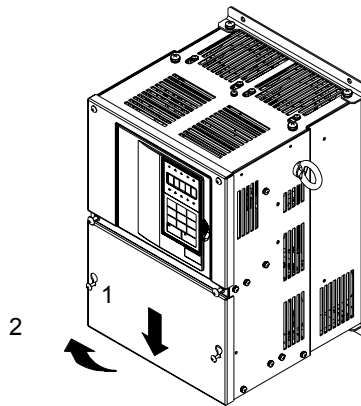

Fig 1.12 Removing the Terminal Cover (Model CIMR-F7Z2022 Shown Above)

◆ Attaching the Terminal Cover

When wiring the terminal block has been completed, attach the terminal cover by reversing the removal procedure.

For Inverters with an output of 18.5 kW or less, insert the tab on the top of the terminal cover into the groove on the Inverter and press in on the bottom of the terminal cover until it clicks into place.

Removing/Attaching the Digital Operator and Front Cover

◆ Inverters of 18.5 kW or Less

To attach optional cards or change the terminal card connector, remove the Digital Operator and front cover in addition to the terminal cover. Always remove the Digital Operator from the front cover before removing the front cover.

The removal and attachment procedures are described below.

■ Removing the Digital Operator

Press the lever on the side of the Digital Operator in the direction of arrow 1 to unlock the Digital Operator and lift the Digital Operator in the direction of arrow 2 to remove the Digital Operator as shown in the following illustration

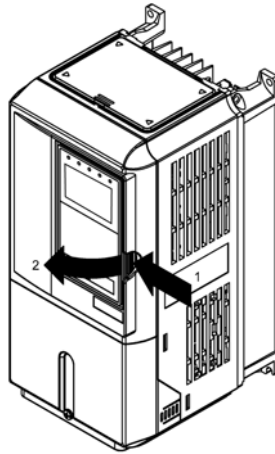

Fig 1.13 Removing the Digital Operator (Model CIMR-F7Z45P5 Shown Above)

■ Removing the Front Cover

Press the left and right sides of the front cover in the directions of arrows 1 and lift the bottom of the cover in the direction of arrow 2 to remove the front cover as shown in the following illustration.

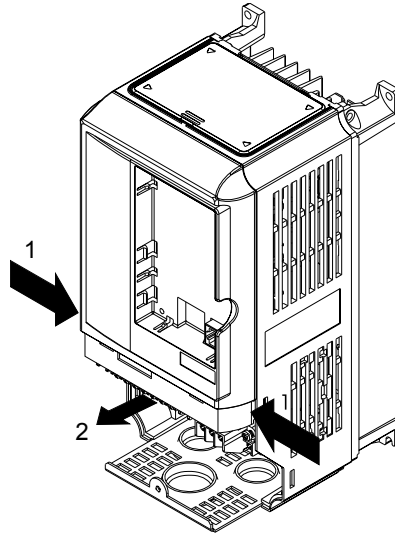

Fig 1.14 Removing the Front Cover (Model CIMR-F7Z45P5 Shown Above)

■ Mounting the Front Cover

After wiring the terminals, mount the front cover to the Inverter by performing the steps to remove the front cover in reverse order.

1. Do not mount the front cover with the Digital Operator attached to the front cover; otherwise, Digital Operator may malfunction due to imperfect contact.
2. Insert the tab of the upper part of the front cover into the groove of the Inverter and press the lower part of the front cover onto the Inverter until the front cover snaps shut.

■ Mounting the Digital Operator

After attaching the terminal cover, mount the Digital Operator onto the Inverter using the following procedure.

1. Hook the Digital Operator at A (two locations) on the front cover in the direction of arrow 1 as shown in the following illustration.
2. Press the Digital Operator in the direction of arrow 2 until it snaps in place at B (two locations)

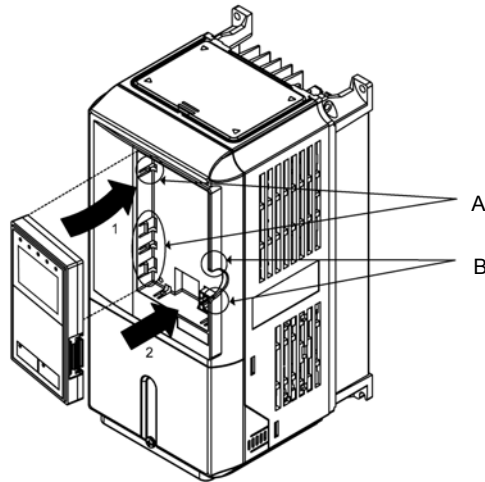

Fig 1.15 Mounting the Digital Operator



IMPORTANT

1. Do not remove or attach the Digital Operator or mount or remove the front cover using methods other than those described above, otherwise the Inverter may break or malfunction due to imperfect contact.
2. Never attach the front cover to the Inverter with the Digital Operator attached to the front cover. Imperfect contact can result.
Always attach the front cover to the Inverter by itself first, and then attach the Digital Operator to the front cover.

◆ Inverters of 22 kW or More

For inverters with an output of 22 kW or more, remove the terminal cover and then use the following procedures to remove the Digital Operator and main cover.

■ Removing the Digital Operator

Use the same procedure as for Inverters with an output of 18.5 kW or less.

■ Removing the Front Cover

Lift up at the location label 1 at the top of the control circuit terminal card in the direction of arrow 2.

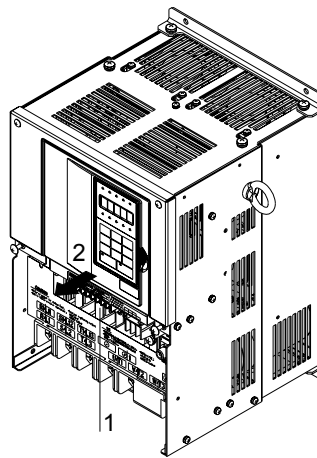

Fig 1.16 Removing the Front Cover (Model CIMR-F7Z2022 Shown Above)

■ Attaching the Front Cover

After completing required work, such as mounting an optional card or setting the terminal card, attach the front cover by reversing the procedure to remove it.

1. Confirm that the Digital Operator is not mounted on the front cover. Contact faults can occur if the cover is attached while the Digital Operator is mounted to it.
2. Insert the tab on the top of the front cover into the slot on the Inverter and press in on the cover until it clicks into place on the Inverter.

■ Attaching the Digital Operator

Use the same procedure as for Inverters with an output of 18.5 kW or less.



2

Wiring

This chapter describes wiring terminals, main circuit terminal connections, main circuit terminal wiring specifications, control circuit terminals, and control circuit wiring specifications.

Connections to Peripheral Devices	2-2
Connection Diagram	2-3
Terminal Block Configuration	2-5
Wiring Main Circuit Terminals	2-6
Wiring Control Circuit Terminals	2-20
Wiring Check.....	2-27
Installing and Wiring Option Cards	2-28

Connections to Peripheral Devices

Examples of connections between the Inverter and typical peripheral devices are shown in *Fig 2.1*.

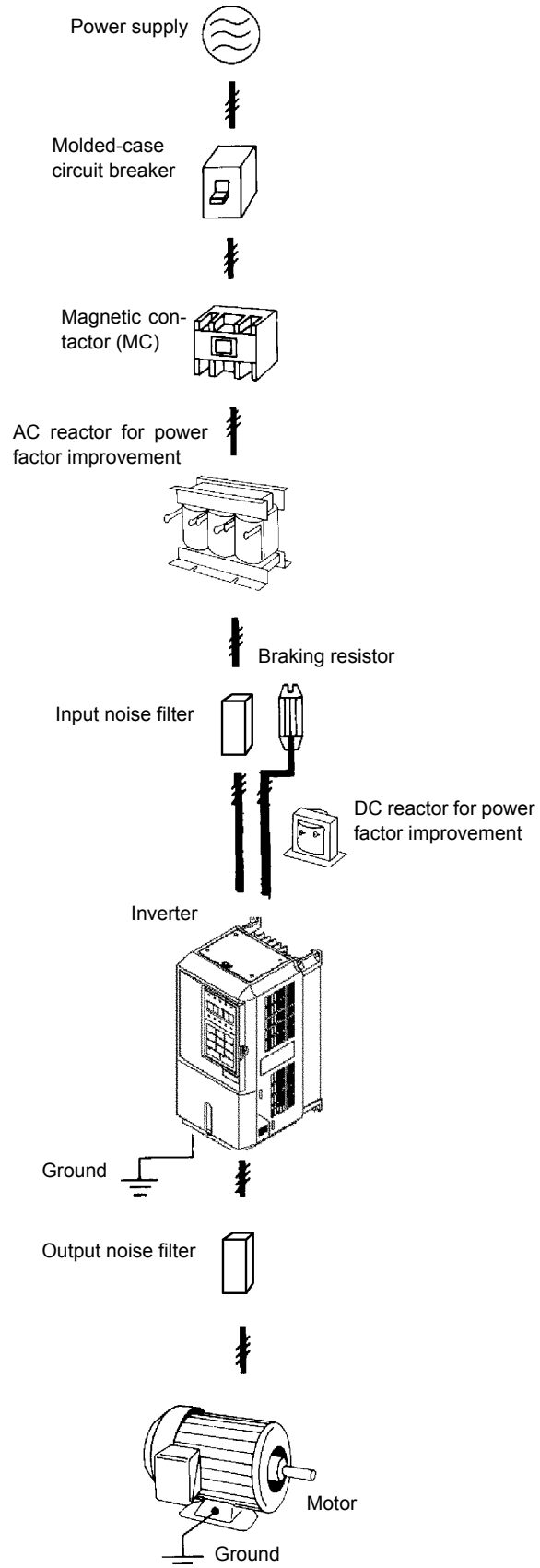

Fig 2.1 Example Connections to Peripheral Devices

Connection Diagram

The connection diagram of the Inverter is shown in [Fig 2.2](#).

When using the Digital Operator, the motor can be operated by wiring only the main circuits.

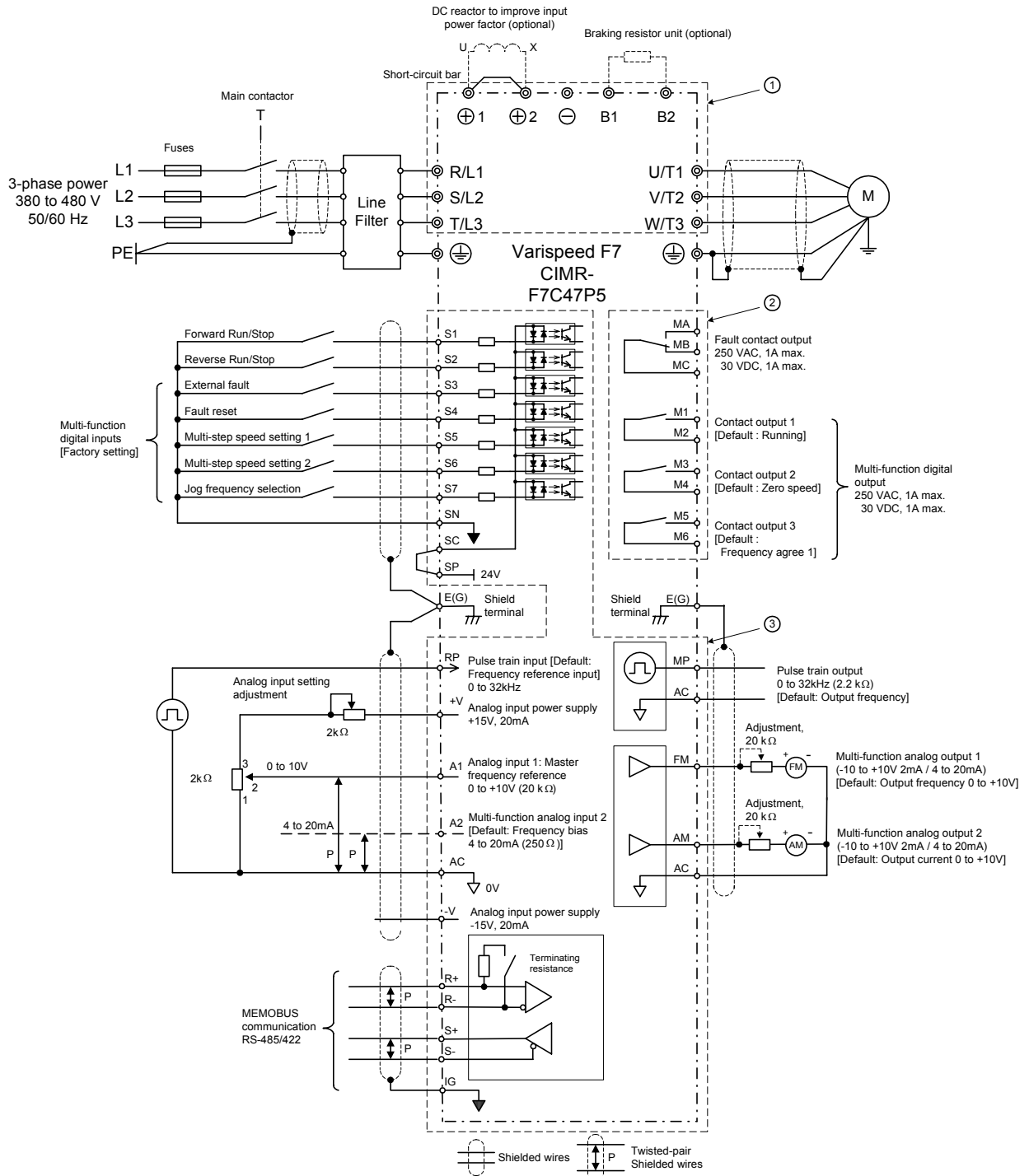

Fig 2.2 Connection Diagram (Model CIMR-F7Z47P5 Shown Above)

◆ Circuit Descriptions

Refer to the numbers indicated in *Fig 2.2*.

- ① These circuits are hazardous and are separated from accessible surfaces by protective separation
- ② These circuits are separated from all other circuits by protective separation consisting of double and reinforced insulation. These circuits may be interconnected with SELV* (or equivalent) or non-SELV* circuits, but not both.
- ③ **Inverters supplied by a four-wire-system source (neutral grounded)**
These circuits are SELV* circuits and are separated from all other circuits by protective separation consisting of double and reinforced insulation. These circuits may only be interconnected with other SELV* (or equivalent) circuits.

Inverters supplied by a three-wire-system source (ungrounded or corner grounded)

These circuits are not separated from hazardous circuits other circuits by protective separation, but only with basic insulation. These circuits must not be interconnected with any circuits which are accessible, unless they are isolated from accessible circuits by supplemental insulation

* SELV = Safety Extra Low Voltage



1. Control circuit terminals are arranged as shown below.

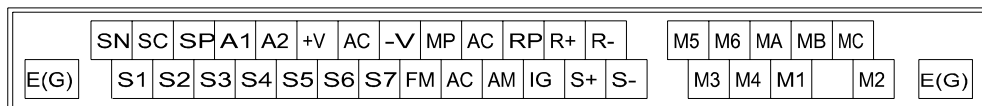

2. The output current capability of the +V terminal is 20 mA.
3. Main circuit terminals are indicated with double circles and control circuit terminals are indicated with single circles.
4. The wiring of the digital inputs S1 to S7 is shown for the connection of contacts or NPN transistors (0V common and sinking mode). This is the default setting.
For the connection of PNP transistors or for using a 24V external power supply, refer to [page 2-24, Sinking/Sourcing Mode](#).
5. The master speed frequency reference can be input either at terminal A1 or at terminal A2 by changing the setting of parameter H3-13. The default setting is terminal A1.
6. The multi-function analog outputs are dedicated meter outputs for analog frequency meters, ammeters, voltmeters, wattmeters, etc. Do not use these outputs for feedback control or for any other control purposes.
7. DC reactors to improve the input power factor are built into 200 V Class Inverters from 22 up to 110 kW and 400 V Class Inverters from 22 up to 300 kW. A DC reactor is an option only for Inverters of 18.5 kW or less. Remove the short circuit bar when connecting a DC reactor.

Terminal Block Configuration

The terminal arrangements are shown in *Fig 2.3* and *Fig 2.4*.

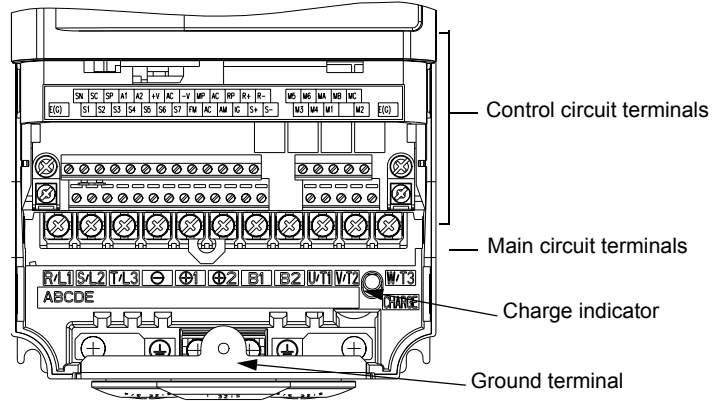

Fig 2.3 Terminal Arrangement (200 V/400 V Class Inverter of 0.4 kW)

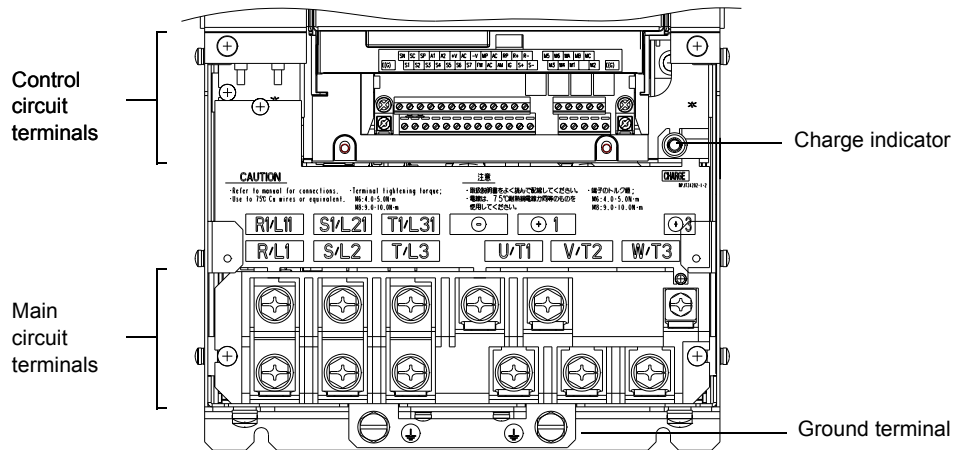

Fig 2.4 Terminal Arrangement (200 V/400 V Class Inverter of 22 kW or more)

Wiring Main Circuit Terminals

◆ Applicable Wire Sizes and Closed-loop Connectors

Select the appropriate wires and crimp terminals from [Table 2.1](#) and [Table 2.2](#). Refer to instruction manual TOE-C726-2 for wire sizes for Braking Resistor Units and Braking Units

Table 2.1 200 V Class Wire Sizes

Inverter Model CIMR-□	Terminal Symbol	Terminal Screws	Tightening Torque (N•m)	Possible Wire Sizes mm ² (AWG)	Recommended Wire Size mm ² (AWG)	Wire Type
F7Z20P4	R/L1, S/L2, T/L3, ⊖, ⊕1, ⊕2, B1, B2, U/T1, V/T2, W/T3	M4	1.2 to 1.5	1.5 to 4 (14 to 10)	2.5 (14)	Power cables, e.g., 600 V vinyl power cables
	⊕					
F7Z20P7	R/L1, S/L2, T/L3, ⊖, ⊕1, ⊕2, B1, B2, U/T1, V/T2, W/T3	M4	1.2 to 1.5	1.5 to 4 (14 to 10)	2.5 (14)	
	⊕					
F7Z21P5	R/L1, S/L2, T/L3, ⊖, ⊕1, ⊕2, B1, B2, U/T1, V/T2, W/T3	M4	1.2 to 1.5	1.5 to 4 (14 to 10)	2.5 (14)	
	⊕					
F7Z22P2	R/L1, S/L2, T/L3, ⊖, ⊕1, ⊕2, B1, B2, U/T1, V/T2, W/T3	M4	1.2 to 1.5	1.5 to 4 (14 to 10)	2 (14)	
	⊕					
F7Z23P7	R/L1, S/L2, T/L3, ⊖, ⊕1, ⊕2, B1, B2, U/T1, V/T2, W/T3	M4	1.2 to 1.5	4 (12 to 10)	4 (12)	
	⊕					
F7Z25P5	R/L1, S/L2, T/L3, ⊖, ⊕1, ⊕2, B1, B2, U/T1, V/T2, W/T3	M4	1.2 to 1.5	6 (10)	6 (10)	
	⊕					
F7Z27P5	R/L1, S/L2, T/L3, ⊖, ⊕1, ⊕2, B1, B2, U/T1, V/T2, W/T3	M5	2.5	10 (8 to 6)	10 (8)	
	⊕					
F7Z2011	R/L1, S/L2, T/L3, ⊖, ⊕1, ⊕2, B1, B2, U/T1, V/T2, W/T3	M5	2.5	16 (6 to 4)	16 (6)	
	⊕					
F7Z2015	R/L1, S/L2, T/L3, ⊖, ⊕1, ⊕2, U/T1, V/T2, W/T3	M6	4.0 to 5.0	25 (4 to 2)	25 (4)	
	B1, B2	M5	2.5	10 (8 to 6)	-	
	⊕	M6	4.0 to 5.0	25 (4)	25 (4)	
F7Z2018	R/L1, S/L2, T/L3, ⊖, ⊕1, ⊕2, U/T1, V/T2, W/T3	M8	9.0 to 10.0	25 to 35 (3 to 2)	25 (3)	
	B1, B2	M5	2.5	10 (8 to 6)	-	
	⊕	M6	4.0 to 5.0	25 (4)	25 (4)	
F7Z2022	R/L1, S/L2, T/L3, ⊖, ⊕1, U/T1, V/T2, W/T3, R1/L11, S1/L21, T1/L31	M8	9.0 to 10.0	25 to 35 (3 to 1)	25 (3)	
	⊕3	M6	4.0 to 5.0	10 to 16 (8 to 4)	-	
	⊕	M8	9.0 to 10.0	25 to 35 (4 to 2)	25 (4)	
F7Z2030	R/L1, S/L2, T/L3, ⊖, ⊕1 U/T1, V/T2, W/T3, R1/L11, S1/L21, T1/L31	M8	9.0 to 10.0	50 (1 to 1/0)	50 (1)	
	⊕3	M6	4.0 to 5.0	10 to 16 (8 to 4)	-	
	⊕	M8	9.0 to 10.0	25 to 35 (4 to 2)	25 (4)	

Table 2.1 200 V Class Wire Sizes

Inverter Model CIMR-□	Terminal Symbol	Terminal Screws	Tightening Torque (N•m)	Possible Wire Sizes mm ² (AWG)	Recommended Wire Size mm ² (AWG)	Wire Type
F7Z2037	R/L1, S/L2, T/L3, ⊖, ⊕1 U/T1, V/T2, W/T3, R1/L11, S1/L21, T1/L31	M10	17.6 to 22.5	70 to 95 (2/0 to 4/0)	70 (2/0)	Power cables, e.g., 600 V vinyl power cables
	⊕3	M8	8.8 to 10.8	6 to 16 (10 to 4)	–	
	⊖	M10	17.6 to 22.5	35 to 70 (2 to 2/0)	35 (2)	
	r/l1, Δ/2	M4	1.3 to 1.4	0.5 to 4 (20 to 10)	1.5 (16)	
F7Z2045	R/L1, S/L2, T/L3, ⊖, ⊕1 U/T1, V/T2, W/T3, R1/L11, S1/L21, T1/L31	M10	17.6 to 22.5	95 (3/0 to 4/0)	95 (3/0)	
	⊕3	M8	8.8 to 10.8	6 to 16 (10 to 4)	–	
	⊖	M10	17.6 to 22.5	50 to 70 (1 to 2/0)	50 (1)	
	r/l1, Δ/2	M4	1.3 to 1.4	0.5 to 4 (20 to 10)	1.5 (16)	
F7Z2055	R/L1, S/L2, T/L3, ⊖, ⊕1	M12	31.4 to 39.2	50 to 95 (1/0 to 4/0)	50 × 2P (1/0 × 2P)	
	U/T1, V/T2, W/T3, R1/L11, S1/L21, T1/L31	M10	17.6 to 22.5	90 (4/0)	90 (4/0)	
	⊕3	M8	8.8 to 10.8	6 to 70 (10 to 2/0)	–	
	⊖	M10	17.6 to 22.5	35 to 95 (3 to 4/0)	50 (1/0)	
	r/l1, Δ/2	M4	1.3 to 1.4	0.5 to 4 (20 to 10)	1.5 (16)	
F7Z2075	R/L1, S/L2, T/L3, ⊖, ⊕1	M12	31.4 to 39.2	95 to 122 (3/0 to 250)	95 × 2P (3/0 × 2P)	
	U/T1, V/T2, W/T3, R1/L11, S1/L21, T1/L31	M10	17.6 to 22.5	95 (3/0 to 4/0)	95 × 2P (3/0 × 2P)	
	⊕3	M8	8.8 to 10.8	6 to 70 (10 to 2/0)	–	
	⊖	M10	17.6 to 22.5	95 to 185 (3/0 to 400)	95 (3/0)	
	r/l1, Δ/2	M4	1.3 to 1.4	0.5 to 4 (20 to 10)	1.5 (16)	
F7Z2090	R/L1, S/L2, T/L3, ⊖, ⊕1	M12	31.4 to 39.2	150 to 185 (250 to 400)	150 × 2P (250 × 2P)	
	U/T1, V/T2, W/T3, R1/L11, S1/L21, T1/L31			95 to 150 (4/0 to 300)	95 × 2P (4/0 × 2P)	
	⊕3	M8	8.8 to 10.8	6 to 70 (10 to 2/0)	–	
	⊖	M12	31.4 to 39.2	70 to 150 (2/0 to 300)	70 × 2P (2/0 × 2P)	
	r/l1, Δ/2	M4	1.3 to 1.4	0.5 to 4 (20 to 10)	1.5 (16)	
F7Z2110	R/L1, S/L2, T/L3, ⊖, ⊕1	M12	31.4 to 39.2	240 to 300 (350 to 600)	240 × 2P, or 50 × 4P (350 × 2P, or 1/0 × 2P)	
	U/T1, V/T2, W/T3, R1/L11, S1/L21, T1/L31			150 to 300 (300 to 600)	150 × 2P, or 50 × 4P (300 × 2P, or 1/0 × 4P)	
	⊕3	M8	8.8 to 10.8	6 to 70 (10 to 2/0)	–	
	⊖	M12	31.4 to 39.2	150 (300)	150 × 2P (300 × 2P)	
	r/l1, Δ/2	M4	1.3 to 1.4	0.5 to 4 (20 to 10)	1.5 (16)	

* The wire thickness is set for copper wires at 75°C

Table 2.2 400 V Class Wire Sizes

Inverter Model CIMR-□	Terminal Symbol	Terminal Screws	Tightening Torque (N•m)	Possible Wire Sizes mm ² (AWG)	Recommended Wire Size mm ² (AWG)	Wire Type
F7Z40P4	R/L1, S/L2, T/L3, ⊖, ⊕1, ⊕2, B1, B2, U/T1, V/T2, W/T3	M4	1.2 to 1.5	1.5 to 4 (14 to 10)	2.5 (14)	Power cables, e.g., 600 V vinyl power cables
	⊕					
F7Z40P7	R/L1, S/L2, T/L3, ⊖, ⊕1, ⊕2, B1, B2, U/T1, V/T2, W/T3	M4	1.2 to 1.5	1.5 to 4 (14 to 10)	2.5 (14)	
	⊕					
F7Z41P5	R/L1, S/L2, T/L3, ⊖, ⊕1, ⊕2, B1, B2, U/T1, V/T2, W/T3	M4	1.2 to 1.5	1.5 to 4 (14 to 10)	2.5 (14)	
	⊕					
F7Z42P2	R/L1, S/L2, T/L3, ⊖, ⊕1, ⊕2, B1, B2, U/T1, V/T2, W/T3	M4	1.2 to 1.5	1.5 to 4 (14 to 10)	2.5 (14)	
	⊕					
F7Z43P7	R/L1, S/L2, T/L3, ⊖, ⊕1, ⊕2, B1, B2, U/T1, V/T2, W/T3	M4	1.2 to 1.5	2.5 to 4 (14 to 10)	4 (12)	
	⊕				2.5 (14)	
F7Z44P0	R/L1, S/L2, T/L3, ⊖, ⊕1, ⊕2, B1, B2, U/T1, V/T2, W/T3	M4	1.2 to 1.5	2.5 to 4 (14 to 10)	4 (12)	
	⊕				2.5 (14)	
F7Z45P5	R/L1, S/L2, T/L3, ⊖, ⊕1, ⊕2, B1, B2, U/T1, V/T2, W/T3	M4	1.2 to 1.5	4 (12 to 10)	4 (12)	
	⊕			2.5 to 4 (14 to 10)	2.5 (14)	
F7Z47P5	R/L1, S/L2, T/L3, ⊖, ⊕1, ⊕2, B1, B2, U/T1, V/T2, W/T3	M4	1.2 to 1.5	6 (10)	6 (10)	
	⊕			4 (12 to 10)	4 (12)	
F7Z4011	R/L1, S/L2, T/L3, ⊖, ⊕1, ⊕2, B1, B2, U/T1, V/T2, W/T3	M5	2.5	6 to 10 (10 to 6)	10 (8)	
	⊕				6 (10)	
F7Z4015	R/L1, S/L2, T/L3, ⊖, ⊕1, ⊕2, B1, B2, U/T1, V/T2, W/T3	M5	2.5	10 (8 to 6)	10 (8)	
	⊕	M5 (M6)	2.5 (4.0 to 5.0)	6 to 10 (10 to 6)	6 (10)	
F7Z4018	R/L1, S/L2, T/L3, ⊖, ⊕1, ⊕2, U/T1, V/T2, W/T3	M6	4.0 to 5.0	10 to 35 (8 to 2)	10 (8)	
	B1, B2	M5	2.5	10 (8)	10 (8)	
	⊕	M6	4.0 to 5.0	10 to 16 (8 to 4)	10 (8)	
F7Z4022	R/L1, S/L2, T/L3, ⊖, ⊕1, ⊕3, U/T1, V/T2, W/T3, R1/L11, S1/L21, T1/L31	M6	4.0 to 5.0	16 (6 to 4)	16 (6)	
	⊕	M8	9.0 to 10.0	16 to 25 (6 to 2)	16 (6)	
F7Z4030	R/L1, S/L2, T/L3, ⊖, ⊕1, ⊕3, U/T1, V/T2, W/T3, R1/L11, S1/L21, T1/L31	M6	4.0 to 5.0	25 (4)	25 (4)	
	⊕	M8	9.0 to 10.0	25 to 35 (4 to 2)	25 (4)	
F7Z4037	R/L1, S/L2, T/L3, ⊖, ⊕1, U/T1, V/T2, W/T3, R1/L11, S1/L21, T1/L31	M8	9.0 to 10.0	25 to 50 (4 to 1/0)	35 (2)	
	⊕3	M6	4.0 to 5.0	10 to 16 (8 to 4)	-	
	⊕	M8	9.0 to 10.0	25 to 35 (4 to 2)	25 (4)	

Table 2.2 400 V Class Wire Sizes

Inverter Model CIMR-□	Terminal Symbol	Terminal Screws	Tightening Torque (N•m)	Possible Wire Sizes mm ² (AWG)	Recommended Wire Size mm ² (AWG)	Wire Type
F7Z4045	R/L1, S/L2, T/L3, ⊖, ⊕1, U/T1, V/T2, W/T3, R1/L11, S1/L21, T1/L31	M8	9.0 to 10.0	35 to 50 (2 to 1/0)	35 (2)	Power cables, e.g., 600 V vinyl power cables
	⊕3	M6	4.0 to 5.0	10 to 16 (8 to 4)	-	
	⊖	M8	9.0 to 10.0	25 to 35 (4 to 2)	25 (4)	
F7Z4055	R/L1, S/L2, T/L3, ⊖, ⊕1, U/T1, V/T2, W/T3, R1/L11, S1/L21, T1/L31	M8	9.0 to 10.0	50 (1 to 1/0)	50 (1)	
	⊕3	M6	4.0 to 5.0	10 to 16 (8 to 4)	-	
	⊖	M8	9.0 to 10.0	25 to 35 (4 to 2)	25 (4)	
F7Z4075	R/L1, S/L2, T/L3, ⊖, ⊕1	M10	31.4 to 39.2	70 to 95 (2/0 to 4/0)	70 (2/0)	
	U/T1, V/T2, W/T3, R1/L11, S1/L21, T1/L31	M10	17.6 to 22.5	50 to 100 (1/0 to 4/0)	50 (1/0)	
	⊕3	M8	8.8 to 10.8	6 to 16 (10 to 4)	-	
	⊖	M10	31.4 to 39.2	35 to 70 (2 to 2/0)	35 (2)	
	r/l1, Δ200/l ₂ 200, Δ400/l ₂ 400	M4	1.3 to 1.4	0.5 to 4 (20 to 10)	1.5 (16)	
F7Z4090	R/L1, S/L2, T/L3, ⊖, ⊕1	M10	31.4 to 39.2	95 (3/0 to 4/0)	95 (4/0)	
	U/T1, V/T2, W/T3, R1/L11, S1/L21, T1/L31	M10	17.6 to 22.5	95 (3/0 to 4/0)	95 (4/0)	
	⊕3	M8	8.8 to 10.8	10 to 16 (8 to 4)	-	
	⊖	M10	31.4 to 39.2	50 to 95 (1 to 4/0)	50 (1)	
	r/l1, Δ200/l ₂ 200, Δ400/l ₂ 400	M4	1.3 to 1.4	0.5 to 4 (20 to 10)	1.5 (16)	
F7Z4110	R/L1, S/L2, T/L3, ⊖, ⊕1	M10	31.4 to 39.2	50 to 95 (1/0 to 4/0)	50 × 2P (1/0 × 2P)	
	U/T1, V/T2, W/T3, R1/L11, S1/L21, T1/L31					
	⊕3	M8	8.8 to 10.8	10 to 70 (8 to 2/0)	-	
	⊖	M12	31.4 to 39.2	70 to 150 (2/0 to 300)	70 (2/0)	
r/l1, Δ200/l ₂ 200, Δ400/l ₂ 400	M4	1.3 to 1.4	0.5 to 4 (20 to 10)	1.5 (16)		
F7Z4132	R/L1, S/L2, T/L3, ⊖, ⊕1	M10	31.4 to 39.2	95 (3/0 to 4/0)	95 × 2P (3/0 × 2P)	
	U/T1, V/T2, W/T3, R1/L11, S1/L21, T1/L31			75 to 95 (2/0 to 4/0)	75 × 2P (2/0 × 2P)	
	⊕3	M8	8.8 to 10.8	10 to 70 (8 to 2/0)	-	
	⊖	M12	31.4 to 39.2	95 to 150 (4/0 to 300)	95 (4/0)	
	r/l1, Δ200/l ₂ 200, Δ400/l ₂ 400	M4	1.3 to 1.4	0.5 to 4 (20 to 10)	1.5 (16)	
F7Z4160	R/L1, S/L2, T/L3, ⊖, ⊕1	M12	31.4 to 39.2	95 to 185 (4/0 to 400)	95 × 2P (4/0 × 2P)	
	U/T1, V/T2, W/T3, R1/L11, S1/L21, T1/L31			95 to 185 (3/0 to 400)	95 × 2P (3/0 × 2P)	
	⊕3	M8	8.8 to 10.8	10 to 70 (8 to 2/0)	-	
	⊖	M12	31.4 to 39.2	50 to 150 (1/0 to 300)	50 × 2P (1/0 × 2P)	
	r/l1, Δ200/l ₂ 200, Δ400/l ₂ 400	M4	1.3 to 1.4	0.5 to 4 (20 to 10)	1.5 (16)	

Table 2.2 400 V Class Wire Sizes

Inverter Model CIMR-□	Terminal Symbol	Terminal Screws	Tightening Torque (N•m)	Possible Wire Sizes mm ² (AWG)	Recommended Wire Size mm ² (AWG)	Wire Type
F7Z4185	R/L1, S/L2, T/L3	M16	78.4 to 98	95 to 300 (4/0 to 600)	150 × 2P (300 × 2P)	Power cables, e.g., 600 V vinyl power cables
	U/T1, V/T2, W/T3, R1/L11, S1/L21, T1/L33				120 × 2P (250 × 2P)	
	⊖, ⊕ 1				300 × 2P (600 × 2P)	
	⊕ 3				–	
	⊕				95 × 2P (3/0 × 2P)	
	r/l1, Δ200/12200, Δ400/12400	M4	1.3 to 1.4	0.5 to 4 (20 to 10)	1.5 (16)	
F7Z4220	R/L1, S/L2, T/L3	M16	78.4 to 98	95 to 300 (4/0 to 600)	240 × 2P (500 × 2P)	Power cables, e.g., 600 V vinyl power cables
	U/T1, V/T2, W/T3, R1/L11, S1/L21, T1/L33				240 × 2P (400 × 2P)	
	⊖, ⊕ 1				120 × 4P (250 × 4P)	
	⊕ 3				–	
	⊕				120 × 2P (250 × 2P)	
	r/l1, Δ200/12200, Δ400/12400	M4	1.3 to 1.4	0.5 to 4 (20 to 10)	1.5 (16)	
F7Z4300	R/L1, S/L2, T/L3	M16	78.4 to 98	95 to 300 (4/0 to 600)	120 × 4P (250 × 4P)	Power cables, e.g., 600 V vinyl power cables
	R1/L11, S1/L21, T1/L31				120 × 4P (4/0 × 4P)	
	U/T1, V/T2, W/T3				240 × 4P (400 × 4P)	
	⊖, ⊕ 1				–	
	⊕ 3				120 × 2P (250 × 2P)	
	⊕				–	
	r/l1, Δ200/12200, Δ400/12400	M4	1.3 to 1.4	0.5 to 4 (20 to 10)	1.5 (16)	

* The wire thickness is set for copper wires at 75°C.



Determine the wire size for the main circuit so that line voltage drop is within 2% of the rated voltage. Line voltage drop is calculated as follows:

$$\text{Line voltage drop (V)} = \sqrt{3} \times \text{wire resistance (W/km)} \times \text{wire length (m)} \times \text{current (A)} \times 10^{-3}$$

◆ Main Circuit Terminal Functions

Main circuit terminal functions are summarized according to terminal symbols in [Table 2.3](#). Wire the terminals correctly for the desired purposes.

Table 2.3 Main Circuit Terminal Functions (200 V Class and 400 V Class)

Purpose	Terminal Symbol	Model: CIMR-F7Z□□□□	
		200 V Class	400 V Class
Main circuit power input	R/L1, S/L2, T/L3	20P4 to 2110	40P4 to 4300
	R1/L11, S1/L21, T1/L31	2022 to 2110	4022 to 4300
Inverter outputs	U/T1, V/T2, W/T3	20P4 to 2110	40P4 to 4300
DC bus terminals	⊕1, ⊖	20P4 to 2110	40P4 to 4300
Braking Resistor Unit connection	B1, B2	20P4 to 2018	40P4 to 4018
DC reactor connection	⊕1, ⊕2	20P4 to 2018	40P4 to 4018
Braking Unit connection	⊕3, ⊖	2022 to 2110	4022 to 4300
Ground	⊖	20P4 to 2110	40P4 to 4300

◆ Main Circuit Configurations

The main circuit configurations of the Inverter are shown in [Table 2.4](#).

Table 2.4 Inverter Main Circuit Configurations

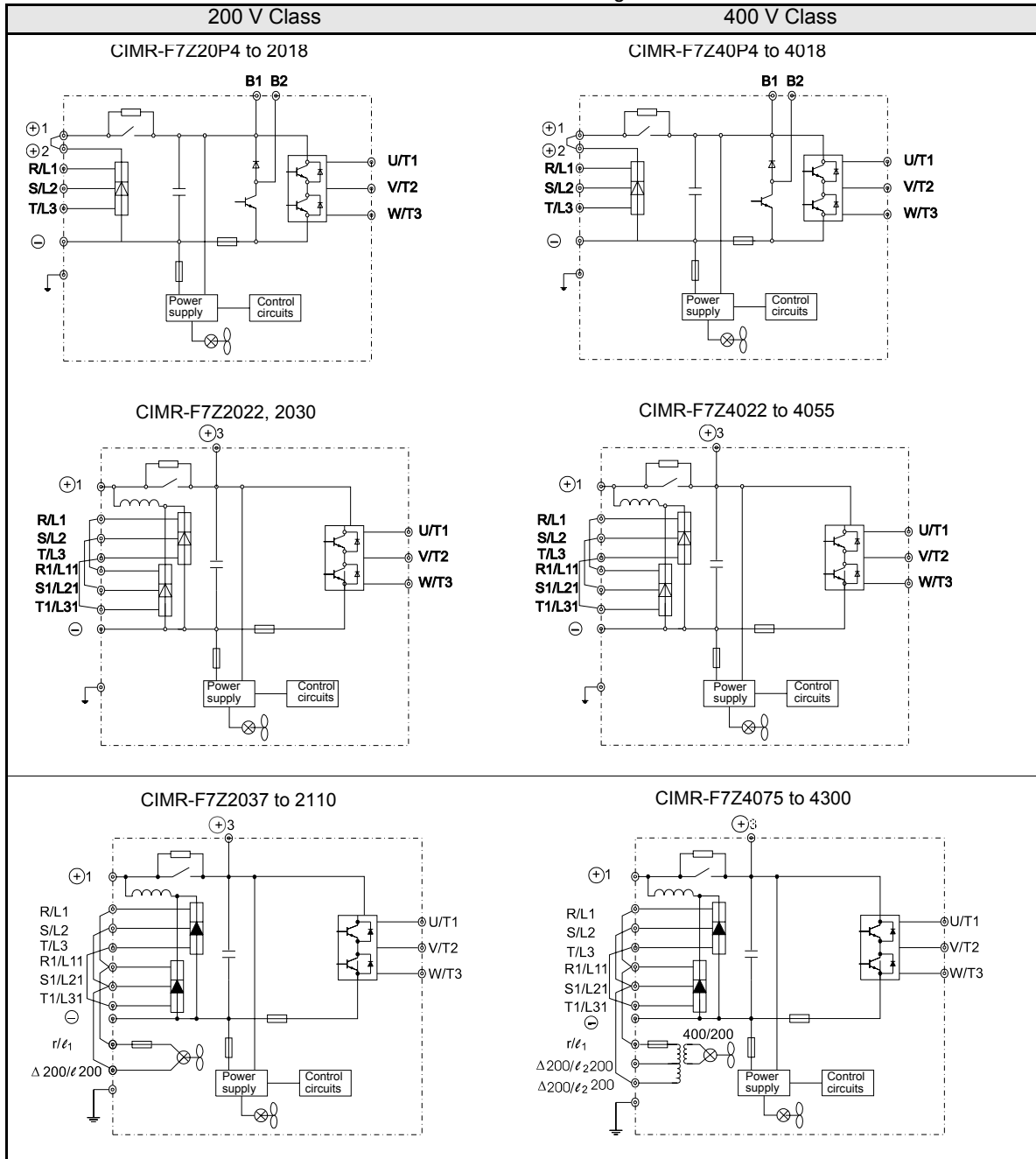

Note: Consult your OYMC representative before using 12-phase rectification.

◆ Standard Connection Diagrams

Standard Inverter connection diagrams are shown in *Fig 2.5*. These are the same for both 200 V Class and 400 V Class Inverters. The connections depend on the Inverter capacity.

■ CIMR-F7Z20P4 to 2018 and 40P4 to 4018

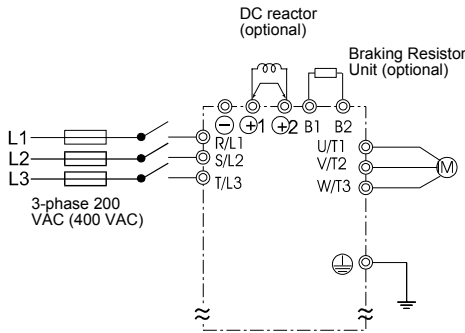

Be sure to remove the short-circuit bar before connecting the DC reactor.

■ CIMR-F7Z2022, 2030, and 4022 to 4055

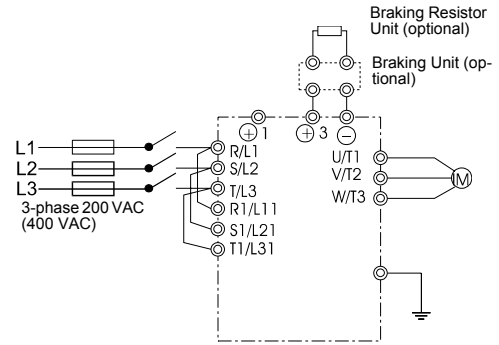

The DC reactor is built in.

■ CIMR-F7Z2037 to 2110

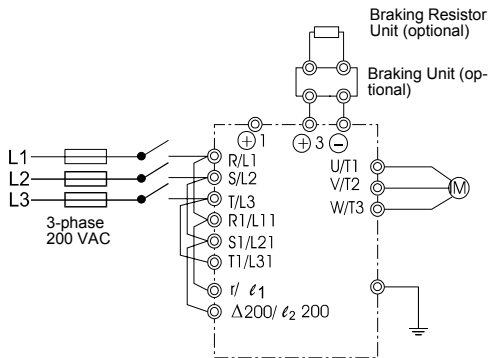

■ CIMR-F7Z4075 to 4300

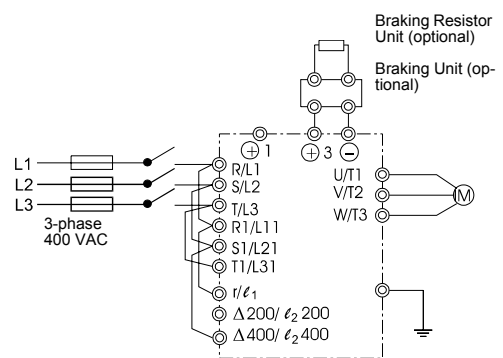

The control power is supplied internally from the DC bus in all inverter models.

Fig 2.5 Main Circuit Terminal Connections

◆ Wiring the Main Circuits

This section describes wiring connections for the main circuit inputs and outputs.

■ Wiring Main Circuit Inputs

Observe the following precautions for the main circuit power supply input.

Installing Fuses

To protect the inverter, it is recommended to use semiconductor fuses like they are shown in the table below.

Table 2.5 Input Fuses

Inverter Type	FUSE		
	Voltage (V)	Current (A)	I^2t (A ² s)
20P4	240	10	12~25
20P7	240	10	12~25
21P5	240	15	23~55
22P2	240	20	34~98
23P7	240	30	82~220
25P5	240	40	220~610
27P5	240	60	290~1300
2011	240	80	450~5000
2015	240	100	1200~7200
2018	240	130	1800~7200
2022	240	150	870~16200
2030	240	180	1500~23000
2037	240	240	2100~19000
2045	240	300	2700~55000
2055	240	350	4000~55000
2075	240	450	7100~64000
2090	240	550	11000~64000
2110	240	600	13000~83000
40P4	480	5	6~55
40P7	480	5	6~55
41P5	480	10	10~55
42P2	480	10	18~55
43P7	480	15	34~72
44P0	480	20	50~570
45P5	480	25	100~570
47P5	480	30	100~640
4011	480	50	150~1300
4015	480	60	400~1800
4018	480	70	700~4100
4022	480	80	240~5800
4030	480	100	500~5800
4037	480	125	750~5800
4045	480	150	920~13000
4055	480	150	1500~13000
4075	480	250	3000~55000
4090	480	300	3800~55000
4110	480	350	5400~23000
4132	480	400	7900~64000
4160	480	450	14000~250000
4185	480	600	20000~250000
4220	480	700	34000~400000
4300	480	900	52000~920000

Installing a Moulded-case Circuit Breaker

When connecting the power input terminals (R/L1, S/L2, and T/L3) to the power supply using a moulded-case circuit breaker (MCCB) observe that the circuit breaker is suitable for the Inverter.

- Choose an MCCB with a capacity of 1.5 to 2 times of the inverter's rated current.
- For the MCCB's time characteristics, be sure to consider the inverter's overload protection (one minute at 150% of the rated output current).

Installing an Earth Leakage Breaker

Inverter outputs use high-speed switching, so high-frequency leakage current is generated. If an earth leakage breaker should be used, select one that detects only the leakage current which is in the frequency range that is hazardous to humans but not high-frequency leakage currents.

- For a special-purpose earth leakage breaker for Inverters, choose one with a sensitivity amperage of at least 30 mA per Inverter.
- When using a general earth leakage breaker, choose one with a sensitivity amperage of 200 mA or more per Inverter and with an operating time of 0.1 s or more.

Installing a Magnetic Contactor

If the power supply for the main circuit is to be shut off by a control circuit, a magnetic contactor can be used.

The following things should be considered:

- The Inverter can be started and stopped by opening and closing the magnetic contactor on the primary side. Frequently opening and closing the magnetic contactor, however, may cause the Inverter to break down. Do not exceed one power upper hour.
- When the Inverter is operated with the Digital Operator, automatic operation cannot be performed after recovery from a power interruption.

Connecting Input Power Supply to the Terminal Block

Input power supply can be connected to any terminal R, S or T on the terminal block; the phase sequence of input power supply is irrelevant to the output phase sequence.

Installing an AC Reactor

If the Inverter is connected to a large-capacity power transformer (600 kW or more) or a phase advancing capacitor is switched, an excessive peak current may flow through the input power circuit, causing the inverter unit to break down.

To prevent this, install an optional AC Reactor on the input side of the Inverter or a DC reactor to the DC reactor connection terminals.

This also improves the power factor on the power supply side.

Installing a Surge Absorber

Always use a surge absorber or diode for inductive loads near the Inverter. These inductive loads include magnetic contactors, electromagnetic relays, solenoid valves, solenoids, and magnetic brakes.

■Wiring the Output Side of Main Circuit

Observe the following precautions when wiring the main output circuits.

Connecting the Inverter and Motor

Connect output terminals U/T1, V/T2, and W/T3 respective to the motor lead wires U, V, and W.

Check that the motor rotates forward with the forward run command. Switch over any two of the output terminals to each other and reconnect if the motor rotates in reverse with the forward run command.

Never Connect a Power Supply to Output Terminals

Never connect a power supply to output terminals U/T1, V/T2, and W/T3. If voltage is applied to the output terminals, the internal circuits of the Inverter will be damaged.

Never Short or Ground Output Terminals

If the output terminals are touched with bare hands or the output wires come into contact with the Inverter case, an electric shock or grounding may occur. This is extremely hazardous. Do not short the output wires.

Do Not Use a Phase Advancing Capacitor

Never connect a phase advancing capacitor to an output circuit. The high-frequency components of the Inverter output may overheat and be damaged and may cause other parts to burn.

Do Not Use an Electromagnetic Switch

Never connect an electromagnetic switch (MC) between the Inverter and motor and turn it ON or OFF during operation. If the MC is turned ON while the Inverter is operating, a large inrush current will be created and the inverter's overcurrent protection will operate.

When using a MC to switch for instance between two motors, stop the Inverter output before operating the MC.

Installing a Thermal Overload Relay Contact for Motor Protection

This Inverter has an electronic thermal protection function to protect the motor from overheating. If, however, more than one motor is operated with one Inverter or a multi-polar motor is used, always install a thermal relay (THR) between the Inverter and the motor and set L1-01 to 0 (no motor protection). The control circuit should be designed so that the contacts of the thermal overload relay turn OFF the magnetic contactor on the main circuit inputs.

Cable Length between Inverter and Motor

If the cable between the Inverter and the motor is long, the high-frequency leakage current will increase, causing the Inverter output current to increase as well. This may affect peripheral devices. To prevent this, adjust the carrier frequency (set in C6-01, C6-02) as shown in [Table 2.6](#). (For details, refer to [Chapter 5 User Parameters](#).)

Table 2.6 Cable Length between Inverter and Motor

Cable length	50 m max.	100 m max.	More than 100 m
Carrier frequency	15 kHz max.	10 kHz max.	5 kHz max.

■Ground Wiring

Observe the following precautions when wiring the ground line.

- Always use the ground terminal of the 200 V Inverter with a ground resistance of less than 100 Ω and that of the 400 V Inverter with a ground resistance of less than 10 Ω.
- Do not share the ground wire with other devices, such as welding machines or power tools.
- Always use a ground wire that complies with technical standards on electrical equipment and minimize the length of the ground wire.
Leakage current flows through the Inverter. Therefore, if the distance between the ground electrode and the ground terminal is too long, potential on the ground terminal of the Inverter will become unstable.
- When using more than one Inverter, be careful not to loop the ground wire.

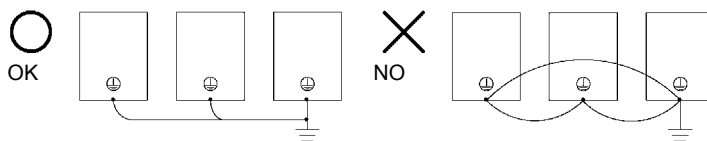

Fig 2.6 Ground Wiring

■Connecting a Inverter Back Mounted Braking Resistor

A Braking Resistor mounted to back side of the Inverter can be used with 200 V and 400 V Class Inverters with outputs from 0.4 to 11 kW. If this type of resistor is used, the internal braking resistor overheat protection can be enabled (see Table below).

Connect the braking resistor as shown in *Fig 2.7*.

L8-01 (Protection selection for internal DB resistor)	1 (Enable overheat protection)
L3-04 (Stall prevention selection during deceleration) (Select either of them.)	0 (Disable stall prevention function)
	3 (Enable stall prevention function with braking resistor)

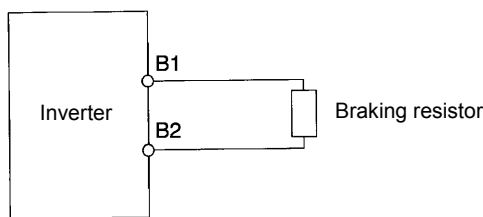

Fig 2.7 Connecting the Braking Resistor



The braking resistor connection terminals are B1 and B2. Do not connect the resistor to any other terminals. Otherwise the resistor and other equipment may get damaged

■ Connecting a Braking Resistor Unit (LKEB) and Braking Unit (CDBR)

Connect a Braking Resistor Unit and Braking Unit to the Inverter as shown in the *Fig 2.8*. The internal braking resistor overheat protection must be disabled (See table below).

L8-01 (Protection selection for internal DB resistor)	0 (Disable overheat protection)
L3-04 (Stall prevention selection during deceleration) (Select either of them.)	0 (Disable stall prevention function)
	3 (Enable stall prevention function with braking resistor)

The Braking Resistor Unit will not work properly if L3-04 is set to 1 (i.e., if stall prevention is enabled for deceleration). Hence the deceleration time may be longer than the set time (C1-02/04/06/08).

To prevent the braking unit/braking resistor from overheating, design the control circuit to turn OFF the power supply using the thermal overload relay contacts of the units as shown in *Fig 2.8*.

200 V and 400 V Class Inverters with 0.4 to 18.5 kW Output Capacity

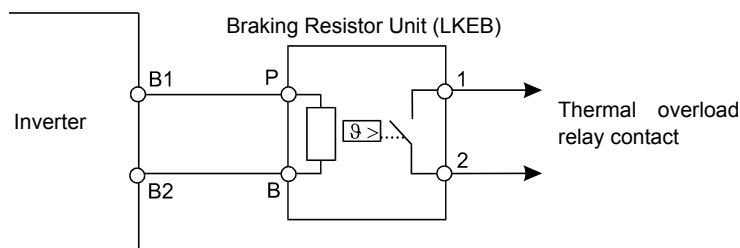

200 V and 400 V Class Inverters with 22 kW or higher Output Capacity

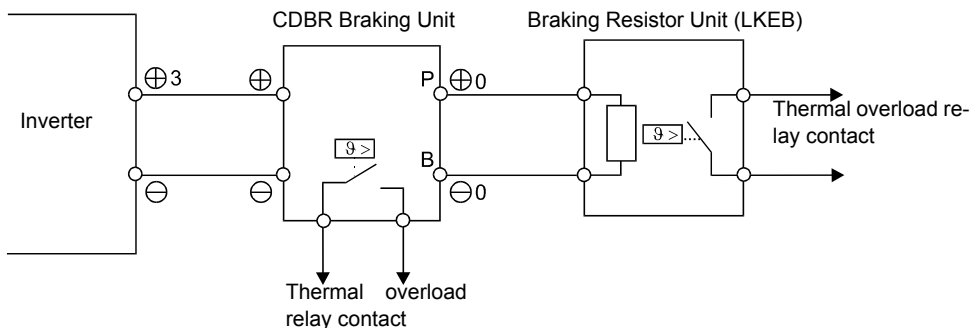

Fig 2.8 Connecting the Braking Resistor and Braking Unit

Connecting Braking Units in Parallel

When connecting two or more Braking Units in parallel, use the wiring and jumper settings like shown in [Fig 2.9](#). There is a jumper for selecting whether each Braking Unit is to be a master or slave. Select “Master” for the first Braking Unit only, and select “Slave” for all other Braking Units (i.e. from the second Unit onwards).

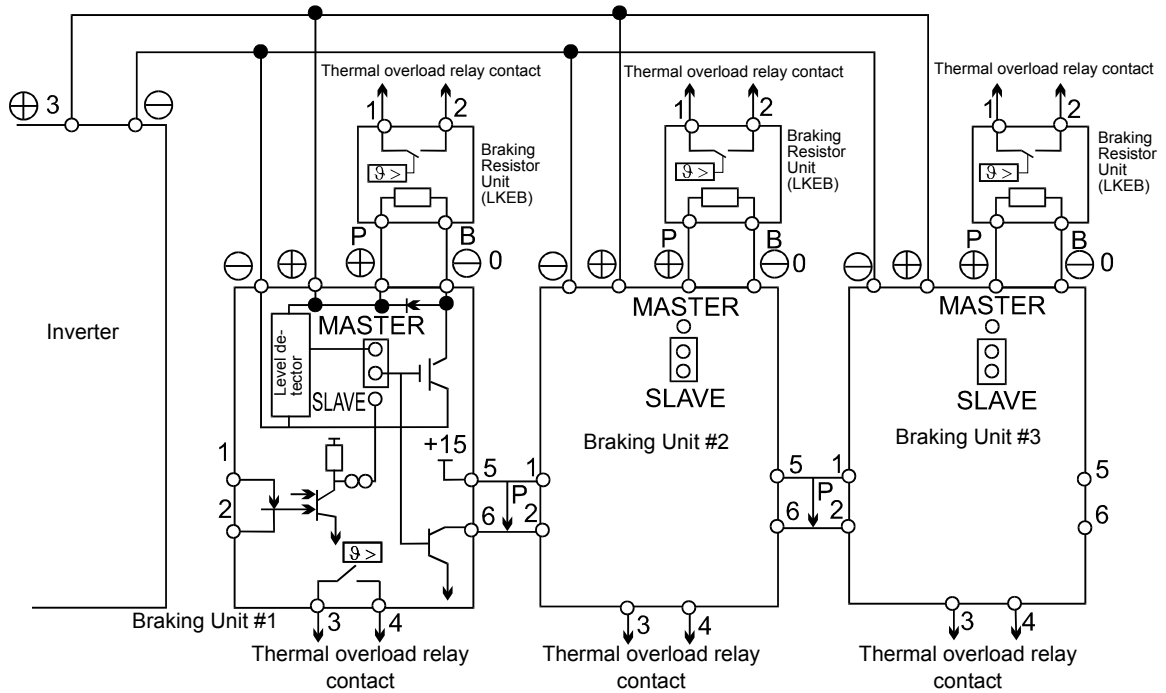

Fig 2.9 Connecting Braking Units in Parallel

Wiring Control Circuit Terminals

◆ Wire Sizes

For remote operation using analog signals, keep the control line length between the Analog Operator or operation signals and the Inverter to 50 m or less, and separate the lines from main power lines or other control circuits to reduce induction from peripheral devices.

When setting frequencies from an external frequency source (and not from a Digital Operator), use shielded twisted-pair wires and ground the shield for the largest area of contact between shield and ground.

The terminal numbers and the appropriate wire sizes are shown in [Table 2.7](#).

Table 2.7 Terminal Numbers and Wire Sizes (Same for all Models)

Terminals	Terminal Screws	Tightening Torque (N•m)	Possible Wire Sizes mm ² (AWG)	Recommended Wire Size mm ² (AWG)	Wire Type
FM, AC, AM, SC, SP, SN, A1, A2, +V, -V, S1, S2, S3, S4, S5, S6, S7 MA, MB, MC, M1, M2, M3, M4, M5, M6 MP, RP, R+, R-, S+, S-, IG	Phoenix type	0.5 to 0.6	Single wire ^{*2} : 0.5 to 2.5 Stranded wire: 0.5 to 1.5 (26 to 14)	0.75 (18)	<ul style="list-style-type: none"> • Shielded, twisted-pair wire^{*1} • Shielded, polyethylene-covered, vinyl sheath cable
E (G)	M3.5	0.8 to 1.0	0.5 to 2.5 (20 to 14)	1 (12)	

* 1. Use shielded twisted-pair cables to input an external frequency reference.

* 2. We recommend using straight solderless terminal on signal lines to simplify wiring and improve reliability.

■ Straight Solderless Terminals for Signal Lines

Models and sizes of straight solderless terminal are shown in the following table.

Table 2.8 Straight Solderless Terminal Sizes

Wire Size mm ² (AWG)	Model	d1	d2	L	Manufacturer
0.25 (24)	AI 0.25 - 8YE	0.8	2	12.5	Phoenix Contact
0.5 (20)	AI 0.5 - 8WH	1.1	2.5	14	
0.75 (18)	AI 0.75 - 8GY	1.3	2.8	14	
1.25 (16)	AI 1.5 - 8BK	1.8	3.4	14	
2 (14)	AI 2.5 - 8BU	2.3	4.2	14	

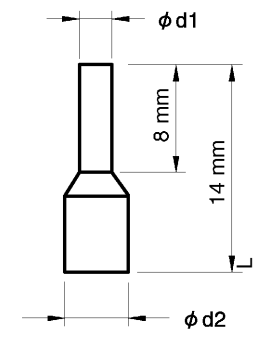

Fig 2.10 Straight Solderless Terminal Sizes

■Wiring Method

Use the following procedure to connect wires to the terminal block.

1. Loosen the terminal screws with a thin-slot screwdriver.
2. Insert the wires from underneath the terminal block.
3. Tighten the terminal screws firmly

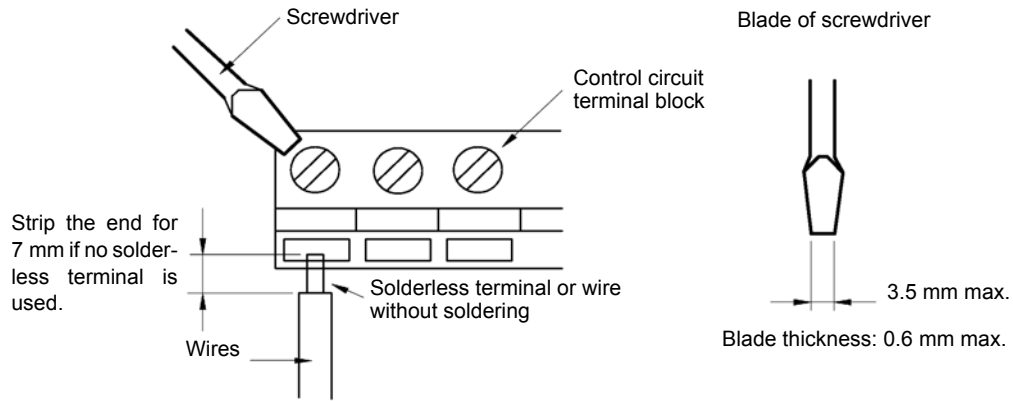

Fig 2.11 Connecting Wires to Terminal Block

◆ Control Circuit Terminal Functions

The functions of the control circuit terminals are shown in *Table 2.9*. Use the appropriate terminals for the correct purposes.

Table 2.9 Control Circuit Terminals with Default Settings

Type	No.	Signal Name	Function		Signal Level
Digital input signals	S1	Forward run/stop command	Forward run when ON; stopped when OFF.		24 VDC, 8 mA Photocoupler
	S2	Reverse run/stop command	Reverse run when ON; stopped when OFF.		
	S3	External fault input ^{*1}	Fault when ON.	Functions are selected by setting H1-01 to H1-05.	
	S4	Fault reset ^{*1}	Reset when ON		
	S5	Multi-step speed reference 1 ^{*1} (Master/auxiliary switch)	Auxiliary frequency reference when ON.		
	S6	Multi-step speed reference 2 ^{*1}	Multi-step setting 2 when ON.		
	S7	Jog frequency reference ^{*1}	Jog frequency when ON.		
	SC	Digital input common	-		-
	SN	Digital Input Neutral	-		-
	SP	Digital Input Power Supply	+24VDC power supply for digital inputs		24 VDC, 250 mA max. ^{*2}
Analog input signals	+V	15 V power output	15 V power supply for analog references		15 V (Max. current: 20 mA)
	-V	-15 V power output	-15 V power supply for analog references		-15 V (Max. current: 20 mA)
	A1	Frequency reference	-10 to +10 V/100%		-10 to +10 V(20 kΩ)
	A2	Multi-function analog input	4 to 20 mA/100% -10 V to +10 V/100%	Function is selected by setting H3-09.	4 to 20 mA(250Ω) -10 V to +10 V(20kΩ)
	AC	Analog reference common	-		-
	E(G)	Shield wire, optional ground line connection point	-		-
Se-quence output signals	M1	Running signal (1NO contact)	Operating when ON.		Relay contacts Contact capacity: 1 A max. at 250 VAC 1 A max. at 30 VDC ^{*3}
	M2				
	M3	Zero speed	Zero level (b2-01) or below when ON		
	M4				
	M5	Speed agreement detection	Within ±2 Hz of set frequency when ON.		
	M6				
	MA	Fault output signal	Fault when CLOSED across MA and MC		
	MB		Fault when OPEN across MB and MC		
MC					
Analog output signals	FM	Multi-function analog output (frequency output)	0 to 10 V, 10V=100% output frequency	Multi-function analog output 1	-10 to +10 V max. ±5% 2 mA max.
	AC	Analog common	-		
	AM	Multi-function analog output (current monitor)	0 to 10 V, 10V=200% Inverter's rated current	Multi-function analog output 2	4 to 20 mA current output

Table 2.9 Control Circuit Terminals with Default Settings

Type	No.	Signal Name	Function	Signal Level
Pulse I/O	RP	Pulse input* ⁴	H6-01 (Frequency reference input)	0 to 32 kHz (3 kΩ) High level voltage 3.5 to 13.2 V
	MP	Pulse monitor	H6-06 (Output frequency)	0 to 32 kHz +15 V output (2.2 kΩ)
RS-485/422	R+	MEMOBUS communications input	For 2-wire RS-485, short R+ and S+ as well as R- and S-.	Differential input, Photo-coupler isolation
	R-			
	S+	MEMOBUS communications output		Differential input, Photo-coupler isolation
	S-			
IG	Signal common	-	-	

- * 1. The default settings are given for terminals S3 to S7. For a 3-wire sequence, the default settings are a 3-wire sequence for S5, multi-step speed setting 1 for S6 and multi-step speed setting 2 for S7.
- * 2. Do not use this power supply for supplying any external equipment.
- * 3. When driving a reactive load, such as a relay coil with DC power supply, always insert a flywheel diode as shown in [Fig 2.12](#).
- * 4. Pulse input specifications are given in the following table.

Low level voltage	0.0 to 0.8 V
High level voltage	3.5 to 13.2 V
H duty	30% to 70%
Pulse frequency	0 to 32 kHz

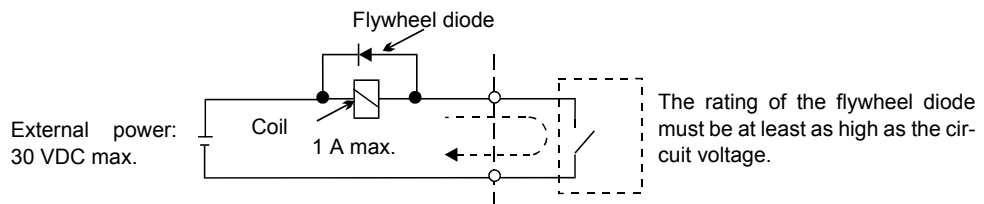

Fig 2.12 Flywheel Diode Connection

■ Jumper CN15 and DIP Switch S1

The jumper CN 15 and DIP switch S1 are described in this section.

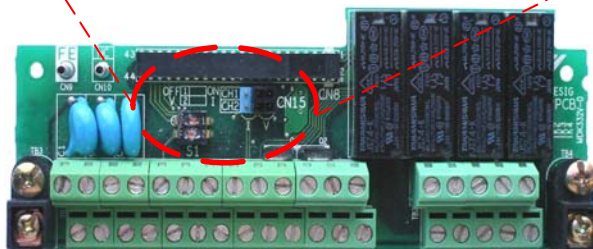
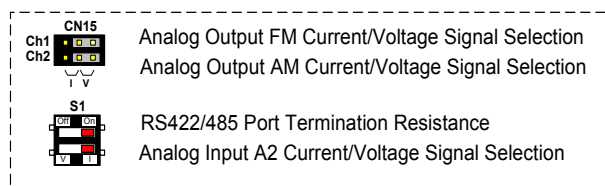

Fig 2.13 Jumper CN15 and DIP Switch S1

The functions of DIP switch S1 and jumper CN15 are shown in the following table.

Table 2.10 DIP Switch S1 and Jumper CN15 Settings

Name	Function	Setting
S1-1	RS-485 and RS-422 terminating resistance	OFF: No terminating resistance ON: Terminating resistance of 110 Ω
S1-2	Input method for analog input A2	V: 0 to 10 V (internal resistance: 20 kΩ) I: 4 to 20 mA (internal resistance: 250 Ω)
CN15-CH1	Multifunction analog output FM voltage/current switch	I: Current output V: Voltage output
CN15-CH2	Multifunction analog output AM voltage/current switch	I: Current output V: Voltage output

■ Sinking/Sourcing Mode

The input terminal logic can be switched between sinking mode (0-V common) and sourcing mode (+24V common) by using the terminals SN, SC, and SP. An external power supply is also supported, providing more freedom in signal input methods.

Table 2.11 Sinking/Sourcing Mode and Input Signals

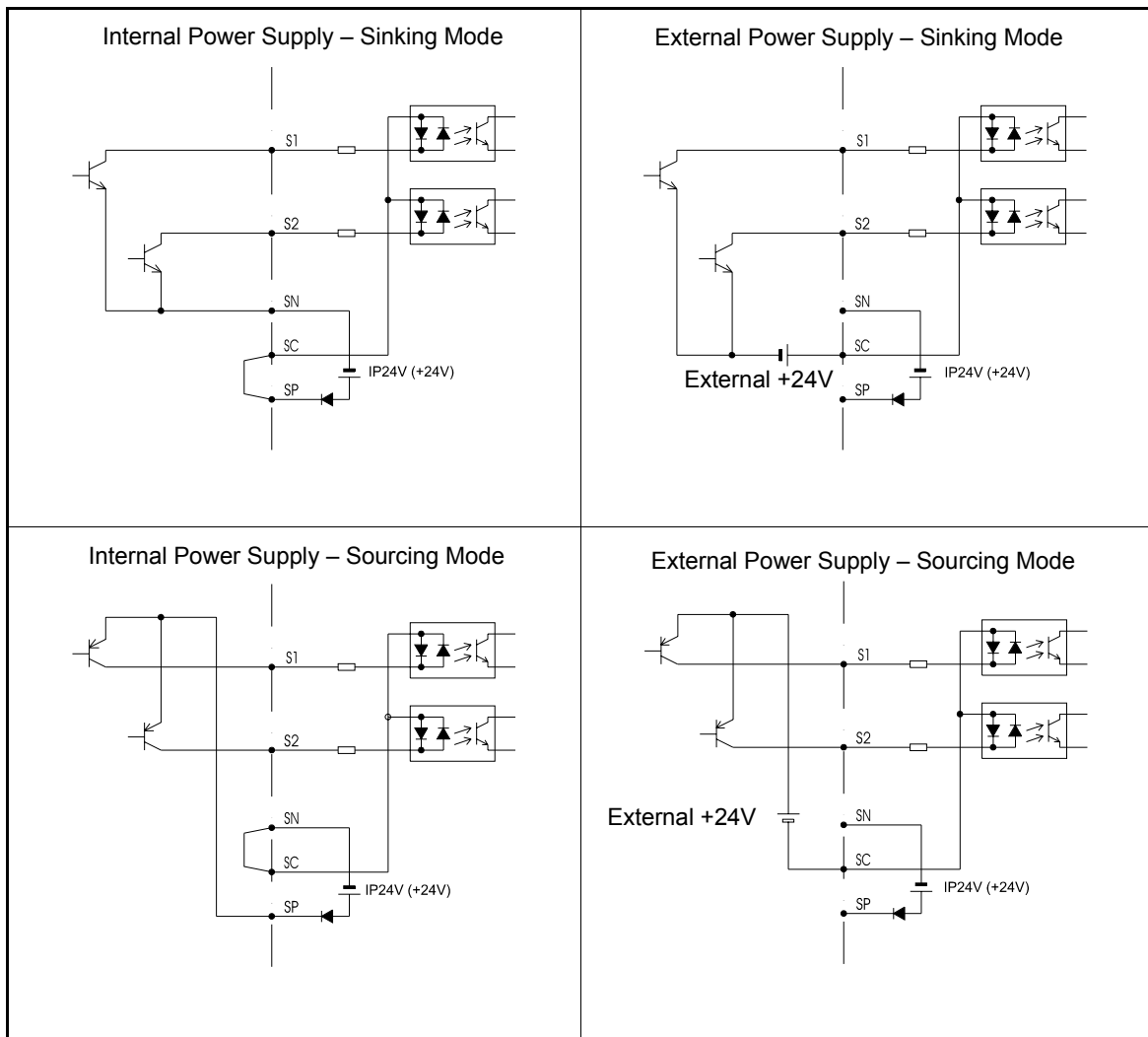

◆ Control Circuit Terminal Connections

Connections to Inverter control circuit terminals are shown in *Fig 2.14*.

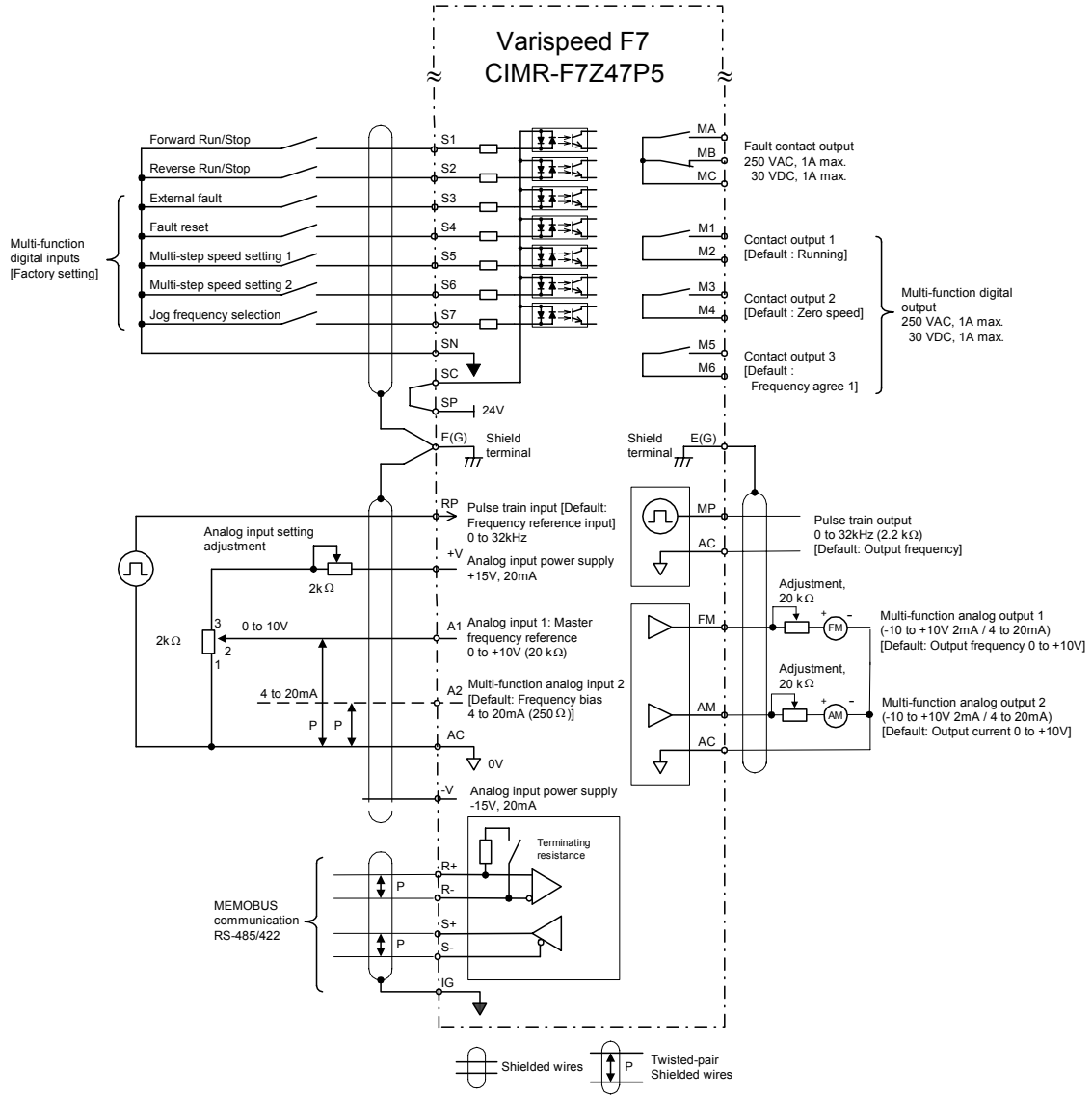

Fig 2.14 Control Circuit Terminal Connections

◆ Control Circuit Wiring Precautions

Observe the following precautions when wiring control circuits.

- Separate control circuit wiring from main circuit wiring (terminals R/L1, S/L2, T/L3, B1, B2, U/T1, V/T2, W/T3, ⊖, ⊕1, ⊕2, and ⊕3) and other high-power lines.
- Separate wiring for control circuit terminals MA, MB, MC, M1, M2, M3, M4, M5, and M6 (contact outputs) from wiring to other control circuit terminals.
- If using an optional external power supply, it shall be a UL Listed Class 2 power supply source.
- Use twisted-pair or shielded twisted-pair cables for control circuits to prevent operating faults.
- Ground the cable shields with the maximum contact area of the shield and ground.
- Cable shields have to be grounded on both cable ends.

Wiring Check

◆ Checks

Check all wiring after wiring has been completed. Do not perform continuity check on control circuits. Perform the following checks on the wiring.

- Is all wiring correct?
- Have no wire clippings, screws, or other foreign material been left?
- Are all screws tight?
- Are any wire ends contacting other terminals?

Installing and Wiring Option Cards

◆ Option Card Models and Specifications

Up to two Option Cards can be mounted in the Inverter. You can mount one card into each of the two places on the controller card (A, and C) like shown in *Fig 2.15*.

Table 2.12 lists the type of Option Cards and their specifications.

Table 2.12 Option Cards

Card	Model	Specifications	Mounting Location
PG Speed Control Cards	PG-B2	Two phase (phase A and B), +12V inputs, max. response frequency: 50 kHz	A
	PG-X2	Three phase (phase A, B, Z), line driver inputs (RS422), max. response frequency: 300 kHz	A
DeviceNet communications card	SI-N1/ PDRT2	Option card for DeviceNet fieldbus	C
Profibus-DP communications card	SI-P1	Option card for Profibus-DP fieldbus	C
InterBus-S communications card	SI-R1	Option card for InterBus-S fieldbus	C
CANOpen communications card	SI-S1	Option card for CANOpen fieldbus	C
Analog Input Cards	AI-14U	2 channel high resolution analog input card Channel 1: 0 to 10 V (20 k Ω) Channel 2: 4 to 20 mA (250 Ω) Resolution: 14 Bit	C
	AI-14B	3 Channel high resolution analog input card Signal level: -10 to +10 V (20 k Ω) 4 to 20 mA (250 Ω) Resolution: 13 Bit + sign	C
Digital Input Cards	DI-08	8 bit digital speed reference input card	C
	DI-16H2	16 bit digital speed reference input card	C

◆ Installation

Before mounting an Option Card, remove the terminal cover and be sure that the charge indicator inside the Inverter does not glow anymore. After that remove the Digital Operator and front cover and then mount the Option Card.

Refer to documentation provided with the Option Card for the mounting instructions for option slots A and C.

■ Preventing C Option Card Connectors from Rising

After installing an Option Card into slot C, insert an Option Clip to prevent the side with the connector from rising. The Option Clip can be easily removed by holding onto the protruding portion of the Clip and pulling it out.

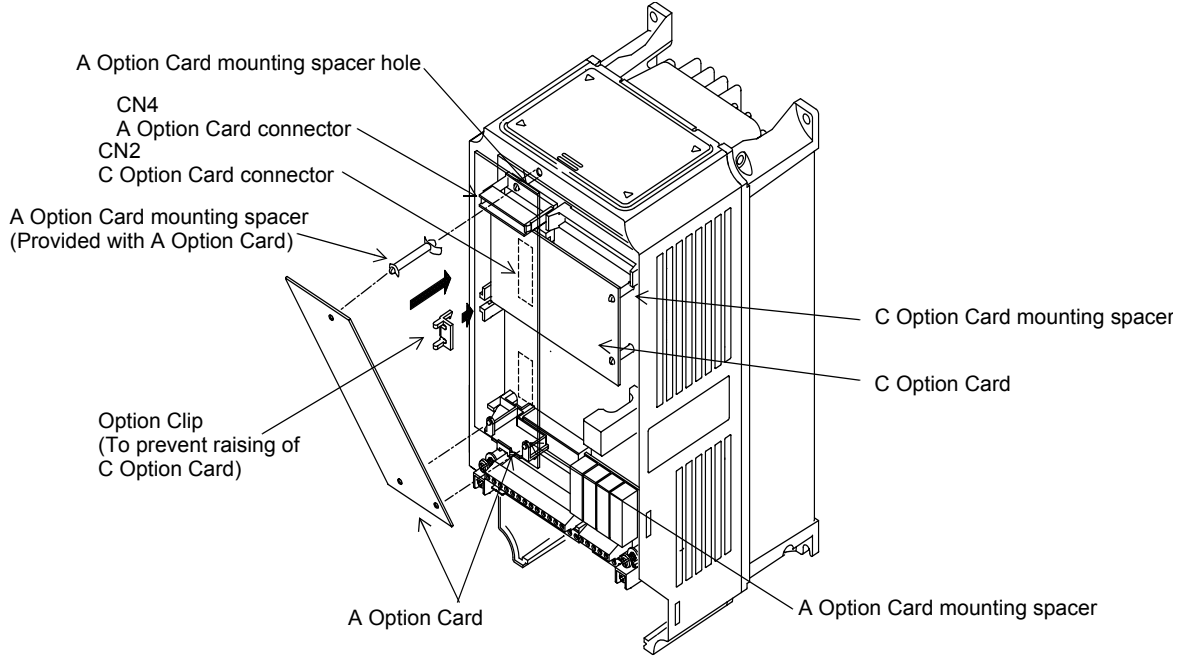

Fig 2.15 Mounting Option Cards

◆ PG Speed Control Card Terminals and Specifications

■ PG-B2

The terminal specifications for the PG-B2 are given in the following table.

Table 2.13 PG-B2 Terminal Specifications

Terminal	No.	Contents	Specifications
TA1	1	Power supply for pulse generator	12 VDC ($\pm 5\%$), 200 mA max.
	2		0 VDC (GND for power supply)
	3	Pulse input terminals phase A	H: +8 to 12 V (max. input frequency: 50 kHz)
	4		GND pulse input phase A
	5	Pulse input terminals phase B	H: +8 to 12 V (max. input frequency: 50 kHz)
	6		GND pulse input phase B
TA2	1	Pulse monitor output terminals phase A	Open collector output, 24 VDC, 30 mA max.
	2		
	3	Pulse monitor output terminals phase B	Open collector output, 24 VDC, 30 mA max.
	4		
TA3	(E)	Shield connection terminal	-

◆ PG-X2

The terminal specifications for the PG-X2 are given in the following table.

Table 2.14 PG-X2 Terminal Specifications

Terminal	No.	Contents	Specifications
TA1	1	Power supply for pulse generator	12 VDC ($\pm 5\%$), 200 mA max.*
	2		0 VDC (GND for power supply)
	3		5 VDC ($\pm 5\%$), 200 mA max.*
	4	Pulse input terminal phase A (+)	Line driver input (RS422 level) (maximum input frequency: 300 kHz)
	5	Pulse input terminal phase A (-)	
	6	Pulse input terminal phase B (+)	
	7	Pulse input terminal phase B (-)	
	8	Pulse input terminal phase Z (+)	
	9	Pulse input terminal phase Z (-)	
		10	Common terminal inputs
TA2	1	Pulse monitor output terminal phase A (+)	Line driver output (RS422 level output)
	2	Pulse monitor output terminal phase A (-)	
	3	Pulse monitor output terminal phase B (+)	
	4	Pulse monitor output terminal phase B (-)	
	5	Pulse monitor output terminal phase Z (+)	
	6	Pulse monitor output terminal phase Z (-)	
		7	Common terminal monitor outputs
TA3	(E)	Shield connection terminal	-

* 5 VDC and 12 VDC cannot be used at the same time.

◆ Wiring

■ Wiring the PG-B2

The following illustrations show wiring examples for the PG-B2 using the option cards power supply or an external power source for supplying the PG.

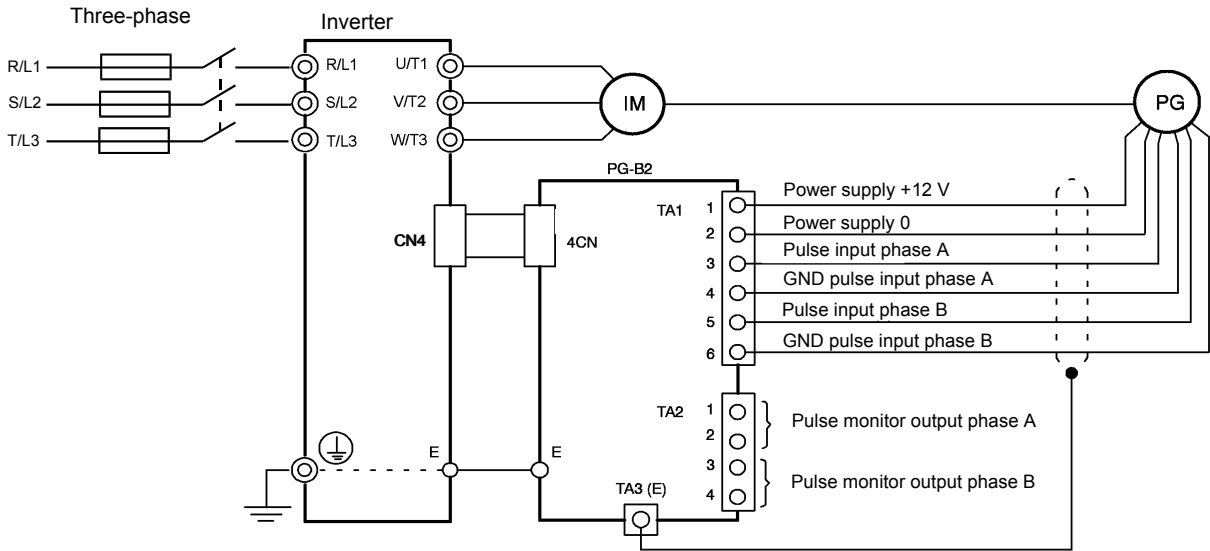

Fig 2.16 PG-B2 Wiring Using the Option Cards Power Supply

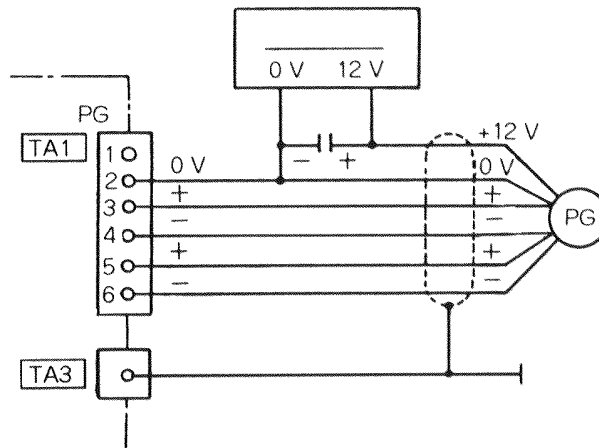
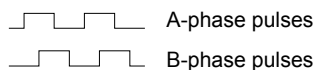

Fig 2.17 PG-B2 Wiring Using a 12 V External Power Supply

- Shielded twisted-pair wires must be used for signal lines.
- Do not use the pulse generator's power supply for anything other than the pulse generator (encoder). Using it for another purpose can cause malfunctions due to noise.
- The length of the pulse generator's wiring must not be more than 100 meters.
- The direction of rotation of the PG can be set in user parameter F1-05. The factory preset is for forward rotation, A-phase advancement.



- When connecting to a voltage-output-type PG (encoder), select a PG that has an output impedance with a current of at least 12 mA to the input circuit photocoupler (diode).
- The pulse monitor dividing ratio can be changed using parameter F1-06.

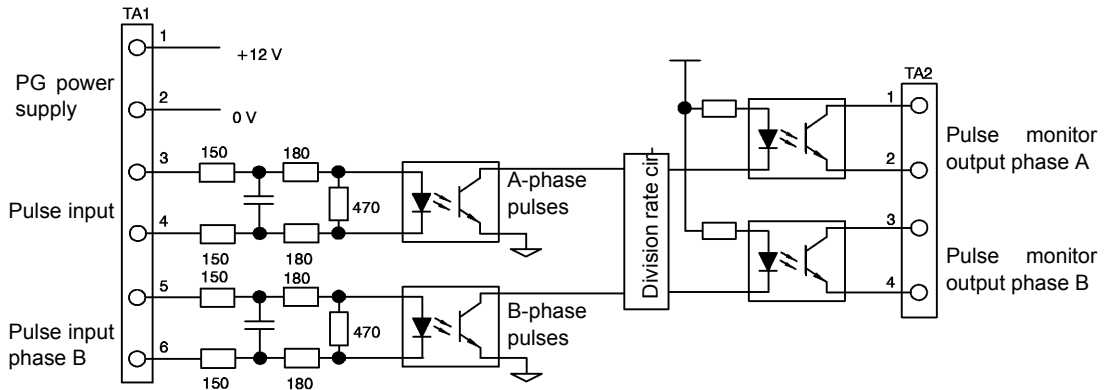

Fig 2.18 I/O Circuit Configuration of the PG-B2

■Wiring the PG-X2

The following illustrations show wiring examples for the PG-X2 using the option cards power supply or an external power source for supplying the PG.

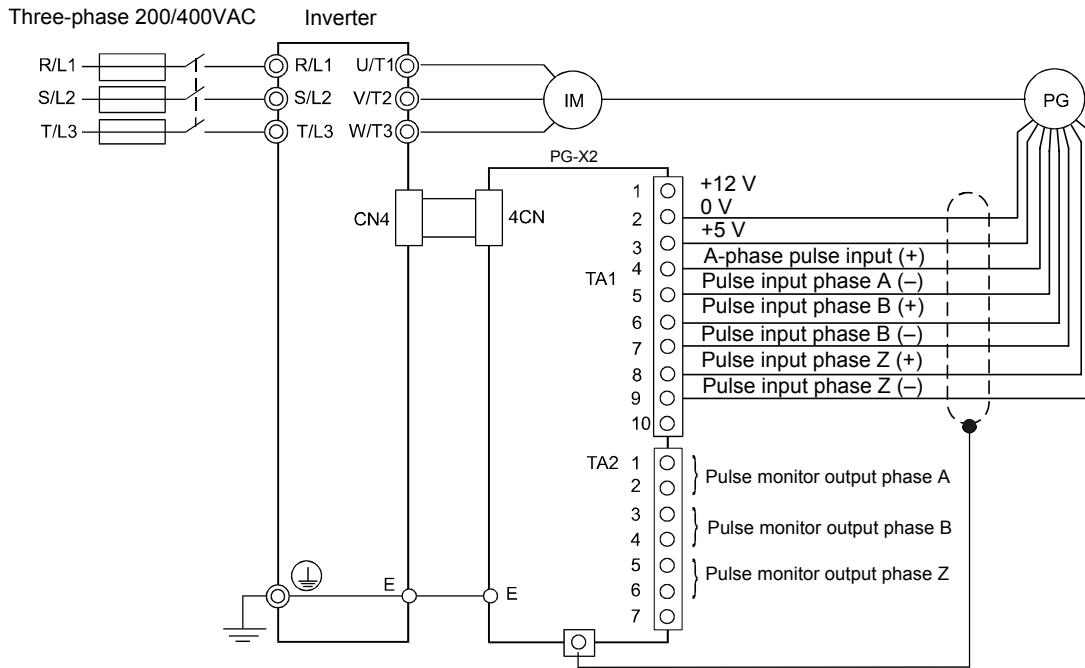

Fig 2.19 PG-X2 Wiring Using the Option Cards Power Supply

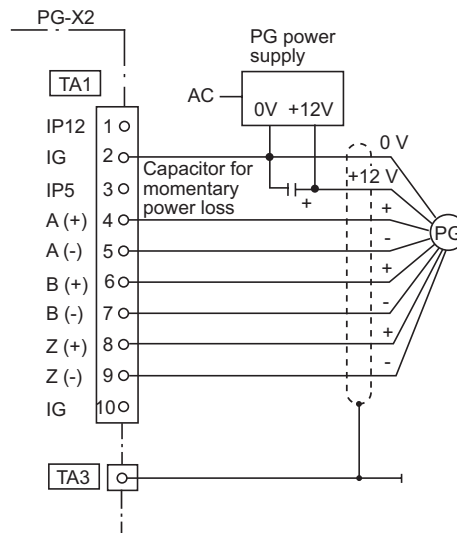

Fig 2.20 PG-X2 Wiring Using a 5 V External Power Supply

- Shielded twisted-pair wires must be used for signal lines.
- Do not use the pulse generator's power supply for anything other than the pulse generator (encoder). Using it for another purpose can cause malfunctions due to noise.
- The length of the pulse generator's wiring must not be more than 100 meters.
- The direction of rotation of the PG can be set in user parameter F1-05 (PG Rotation). The factory preset is for motor forward rotation, A-phase advancement.

◆ Wiring Terminal Blocks

Do not use more cables longer than 100 meters for wiring the PG (encoder) and keep them separate from power lines.

Use shielded, twisted-pair wires for pulse inputs and pulse output monitor wires, and connect the shield to the shield connection terminal.

■ Wire Sizes (Same for All Models)

Terminal wire sizes are shown in [Table 2.15](#).

Table 2.15 Wire Sizes

Terminal	Terminal Screws	Wire Thickness (mm ²)	Wire Type
Pulse generator power supply Pulse input terminal Pulse monitor output terminal	-	Stranded wire: 0.5 to 1.25 Single wire: 0.5 to 1.25	<ul style="list-style-type: none"> • Shielded, twisted-pair wire • Shielded, polyethylene-covered, vinyl sheath cable (KPEV-S by Hitachi Electric Wire or equivalent)
Shield connection terminal	M3.5	0.5 to 2	

■ Straight Solderless Terminals

We recommend using straight solderless terminal on signal lines to simplify wiring and improve reliability.

Refer to [Table 2.8](#) for specifications.

■ Cable Lug Connector Sizes and Tightening Torque

The lug sizes and tightening torques for various wire sizes are shown in [Table 2.16](#).

Table 2.16 Cable Lugs and Tightening Torque

Wire Thickness [mm ²]	Terminal Screws	Crimp Terminal Size	Tightening Torque (N • m)
0.5	M3.5	1.25 - 3.5	0.8
0.75		1.25 - 3.5	
1.25		1.25 - 3.5	
2		2 - 3.5	

■ Precautions

The wiring method is the same as the one used for straight solderless terminals. Refer to [page 2-33](#). Observe the following precautions when wiring.

- Separate the control signal lines for the PG Speed Control Card from main power lines and other control circuits.
- The shield must be connected to prevent operational errors caused by noise. Also, do not use any lines that are more than 100 m long.
- Connect the shield (green grounding cable of the option card) to the shield terminal (E).
- Do not solder the ends of wires. Doing so may cause contact faults.
- When not using straight solderless terminals, strip the wires to a length of approximately 5.5 mm
- A separate power supply is required if the PG power supply consumption is higher than 200 mA. (If momentary power loss must be handled, use a backup capacitor or other method.)
- Make sure not to exceed the PG cards maximum input frequency. The output frequency of the pulse generator can be calculated using the following formula.

$$f_{PG} \text{ (Hz)} = \frac{\text{Motor speed at maximum output frequency (min}^{-1}\text{)}}{60} \times \text{PG rating (p/rev)}$$



3

Digital Operator and Modes

This chapter describes Digital Operator displays and functions, and provides an overview of operating modes and switching between modes.

Digital Operator and Modes	3-1
Modes	3-4

Digital Operator

This section describes the displays and functions of the Digital Operator.

◆ Digital Operator Display

The key names and functions of the Digital Operator are described below.

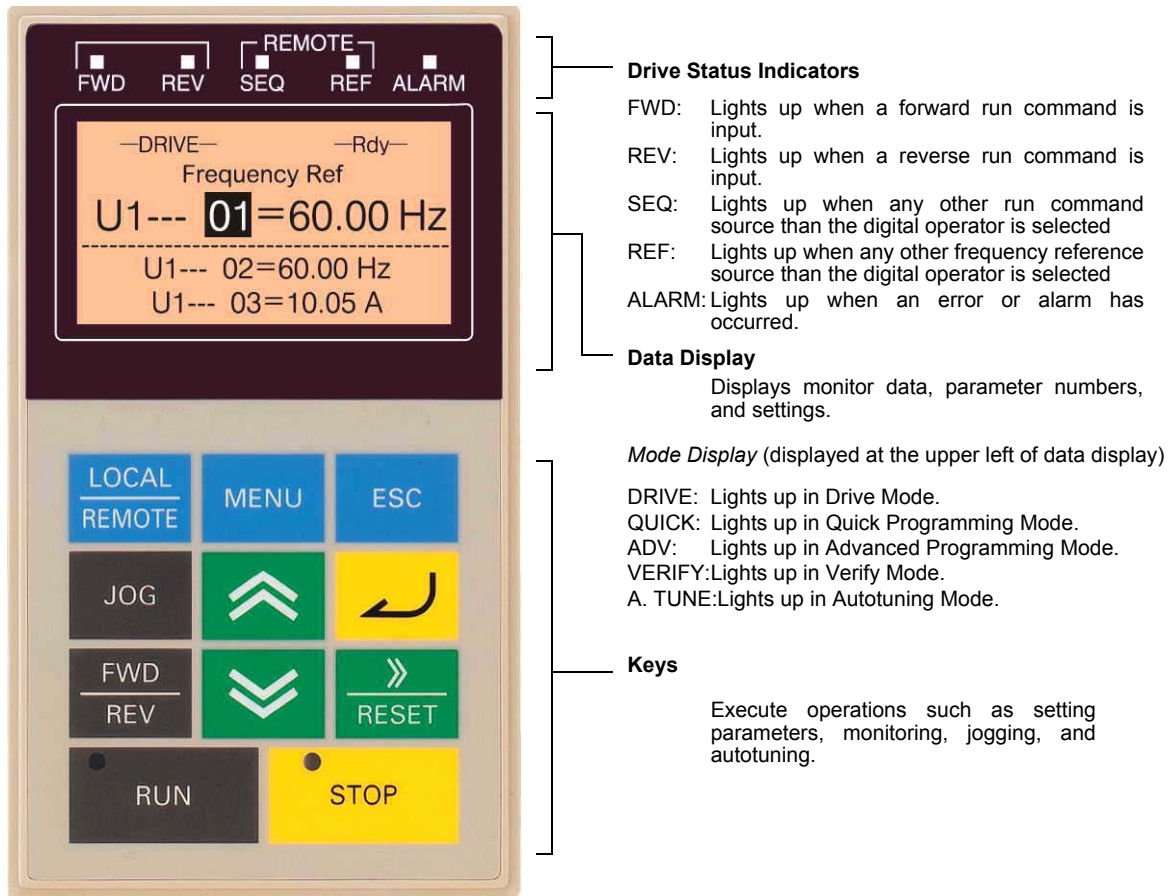

Fig 3.1 Digital Operator Component Names and Functions









◆ Digital Operator Keys

The names and functions of the Digital Operator Keys are described in [Table 3.1](#).

Table 3.1 Key Functions

Key	Name	Function
LOCAL REMOTE	LOCAL/REMOTE Key	Switches between operation via the Digital Operator (LOCAL) and control circuit terminal operation (REMOTE). This key can be enabled or disabled by setting parameter o2-01.
MENU	MENU Key	Selects modes.
ESC	ESC Key	Returns to the status before the DATA/ENTER key was pressed.

Table 3.1 Key Functions (Continued)

Key	Name	Function
	JOG Key	Enables jog operation when the Inverter is operated from the Digital Operator.
	FWD/REV Key	Selects the rotation direction of the motor when the Inverter is operated from the Digital Operator.
	Shift/RESET Key	Sets the active digit when programming parameters. Also acts as the Reset key when a fault has occurred.
	Increment Key	Selects menu items, sets parameter numbers, and increments set values. Used to move to the next item or data.
	Decrement Key	Selects menu items, sets parameter numbers, and decrements set values. Used to move to the previous item or data.
	DATA/ENTER Key	Pressed to enter menu items, parameters, and set values. Also used to switch from one screen to another.
	RUN Key	Starts the Inverter operation when the Inverter is being controlled by the Digital Operator.
	STOP Key	Stops Inverter operation. This key can be enabled or disabled when operating from the control circuit terminal by setting parameter o2-02.

* Except in diagrams, Keys are referred to the key names listed in the above table.

There are indicators on the upper left of the RUN and STOP keys on the Digital Operator. These indicators will light and flash to indicate operating status.

The RUN key indicator will flash and the STOP key indicator will light during initial excitation or DC braking. The relationship between the indicators on the RUN and STOP keys and the Inverter status is shown in Fig 3.2.

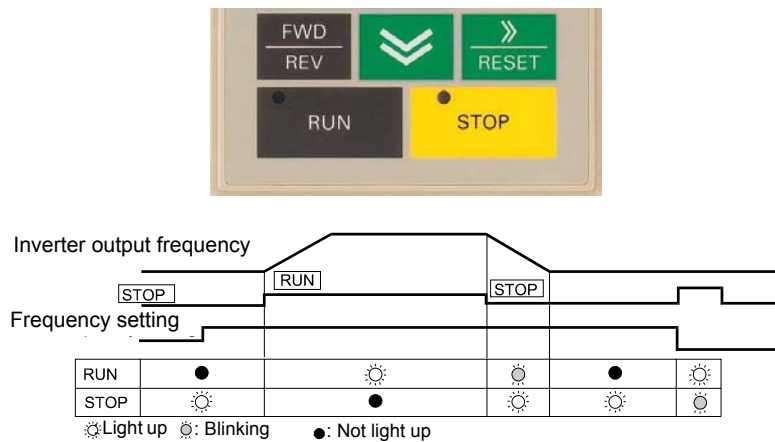

Fig 3.2 RUN and STOP Indicators

Modes

This section describes the Inverter's modes and switching between modes.

◆ Inverter Modes

The Inverter's parameters and monitoring functions are organized in groups called modes that make it easier to read and set parameters. The Inverter is equipped with 5 modes.

The 5 modes and their primary functions are shown in the [Table 3.2](#).

Table 3.2 Modes

Mode	Primary function(s)
Drive mode	Use this mode to start/stop the inverter, to monitor values such as the frequency references or output current and for displaying fault information or the fault history.
Quick programming mode	Use this mode to read and set the basic parameters.
Advanced programming mode	Use this mode to reference and set all parameters.
Verify mode	Use this mode to read/set parameters that have been changed from their factory-set values.
Autotuning mode*	Use this mode when running a motor with unknown motor data in the vector control modes. The motor data are measured/calculated and set automatically. This mode can also be used to measure only the motor line-to-line resistance.

* Always perform autotuning with the motor before operating in the vector control modes.

◆ Switching Modes

The mode selection display will appear when the MENU key is pressed. Press the MENU key from the mode selection display to switch through the modes in sequence.

Press the DATA/ENTER key to enter a mode and to switch from a monitor display to the setting display.

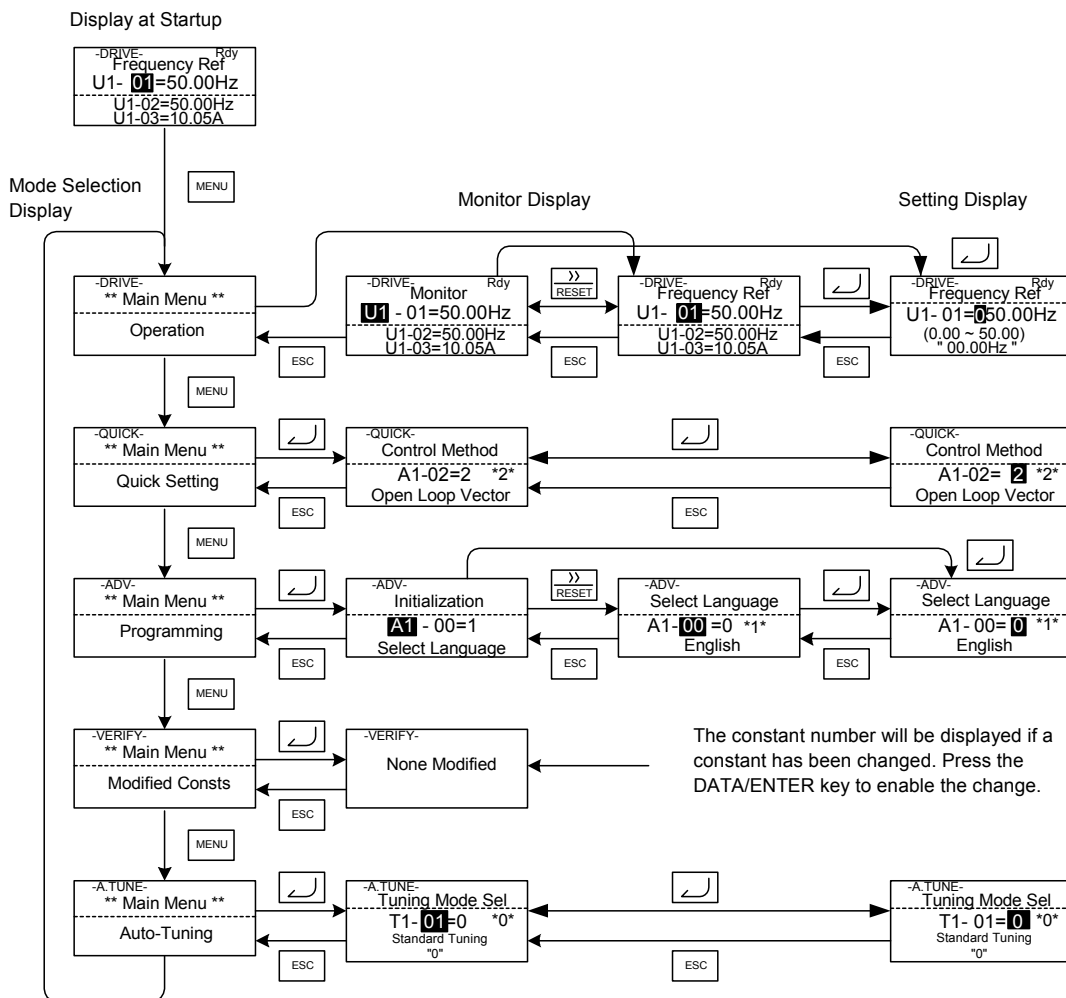

Fig 3.3 Mode Transitions



To run the inverter after viewing/changing parameters press the MENU key and the DATA/ENTER key in sequence to enter the Drive mode. A Run command is not accepted as long as the drive is in any other mode.

◆ Drive Mode

The Drive mode is the mode in which the Inverter can be operated. All monitor parameters (U1-□□) as well as fault information and the fault history can be displayed in this mode

When b1-01 (Reference selection) is set to 0, the frequency can be changed from the frequency setting display using the Increment, Decrement, and Shift/RESET keys. The parameter will be written and the display returns to the Monitor display.

■ Example Operations

Example key operations in drive mode are shown in the following figure.

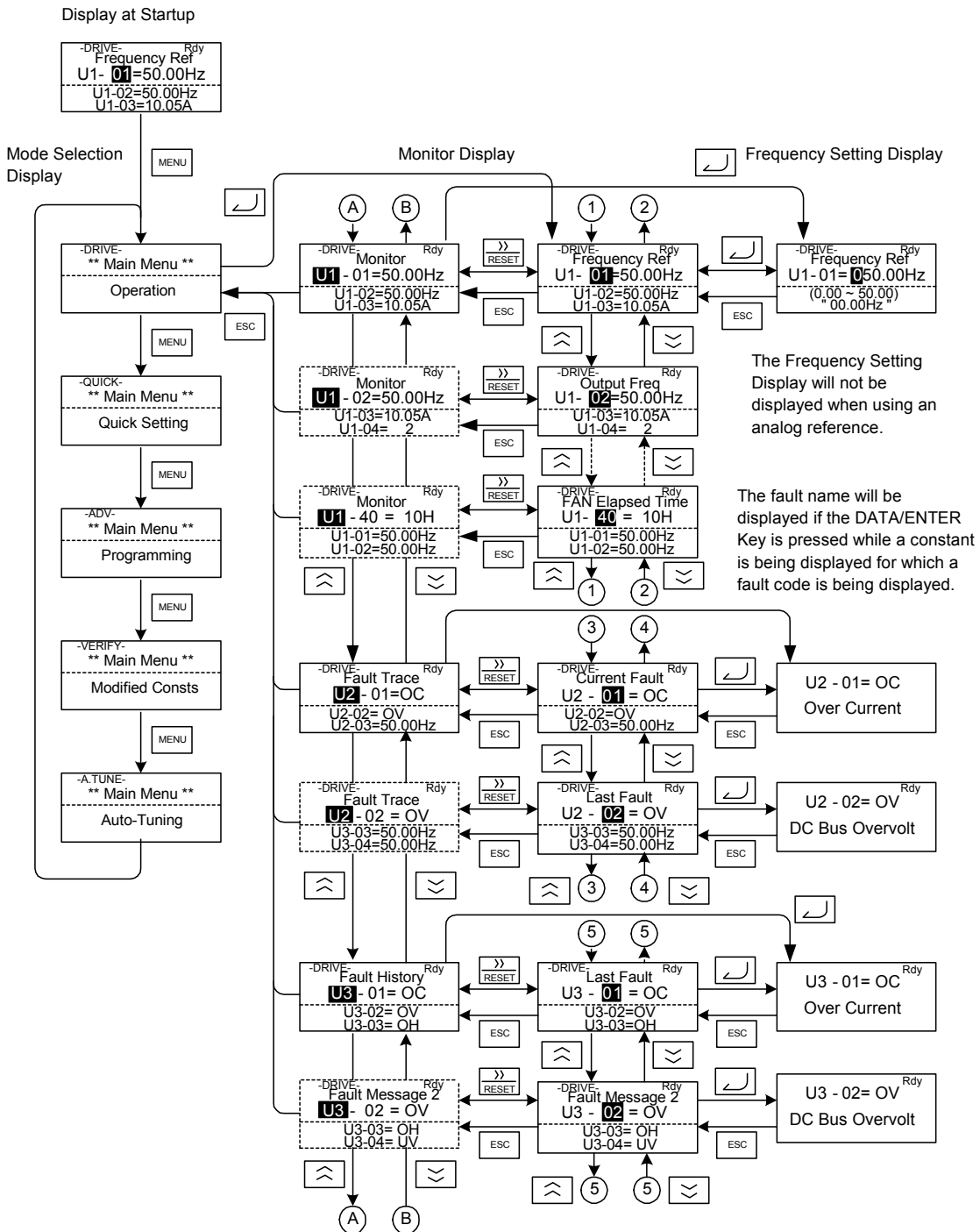

Fig 3.4 Operations in Drive Mode

- Note: 1. When changing the display with the Increment / Decrement keys, the next display after the one for the last parameter number will be the one for the first parameter number and vice versa. For example, the next display after the one for U1-01 will be U1-40. This is indicated in the figures by the letters A and B and the numbers 1 to 6.
2. The display for the first monitor parameter (frequency reference) will be displayed when power is turned ON. The monitor item displayed at startup can be set in o1-02 (Monitor Selection after Power Up). Operation cannot be started from the mode selection display.

◆ Quick Programming Mode

In quick programming mode, the basic parameters required for Inverter trial operation can be monitored and set.

The parameters can be changed from the setting displays. Use the Increment, Decrement, and Shift/RESET keys to change the frequency. The parameter will be written and the monitor display will be returned to when the DATA/ENTER key is pressed after changing the setting.

Refer to *Chapter 5 User Parameters* for details on the parameters displayed in quick programming mode.

■ Example Operations

Example key operations in quick programming mode are shown in the following figure.

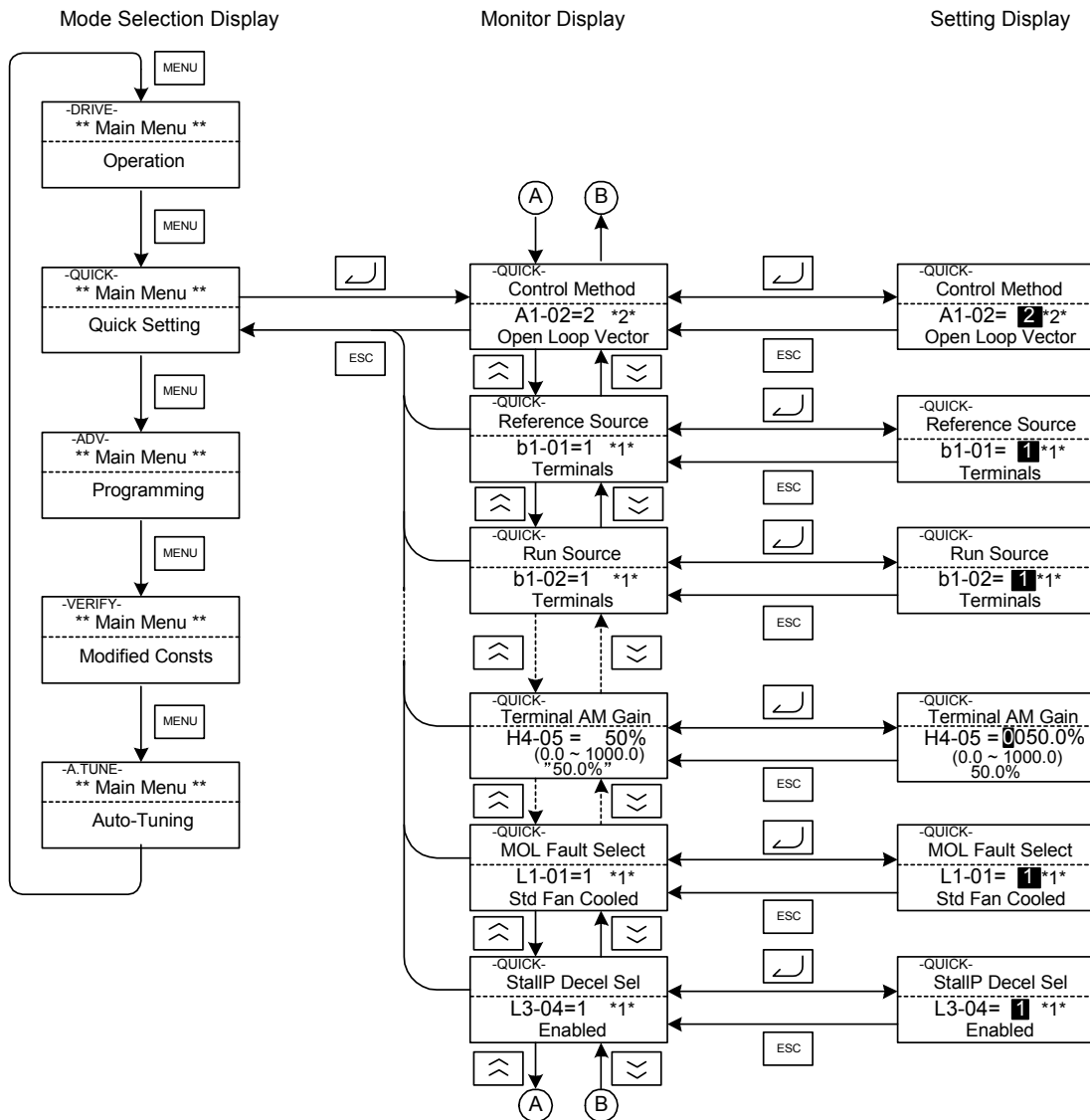

Fig 3.5 Operations in Quick Programming Mode

◆ Advanced Programming Mode

In advanced programming mode all Inverter parameters can be monitored and set.

A parameter can be changed from the setting displays using the Increment, Decrement, and Shift/RESET keys. The parameter will be saved and the display will return to monitor display when the DATA/ENTER key is pressed after changing the setting.

Refer to *Chapter 5 User Parameters* for details on the parameters.

■ Example Operations

Example key operations in advanced programming mode are shown in the following figure.

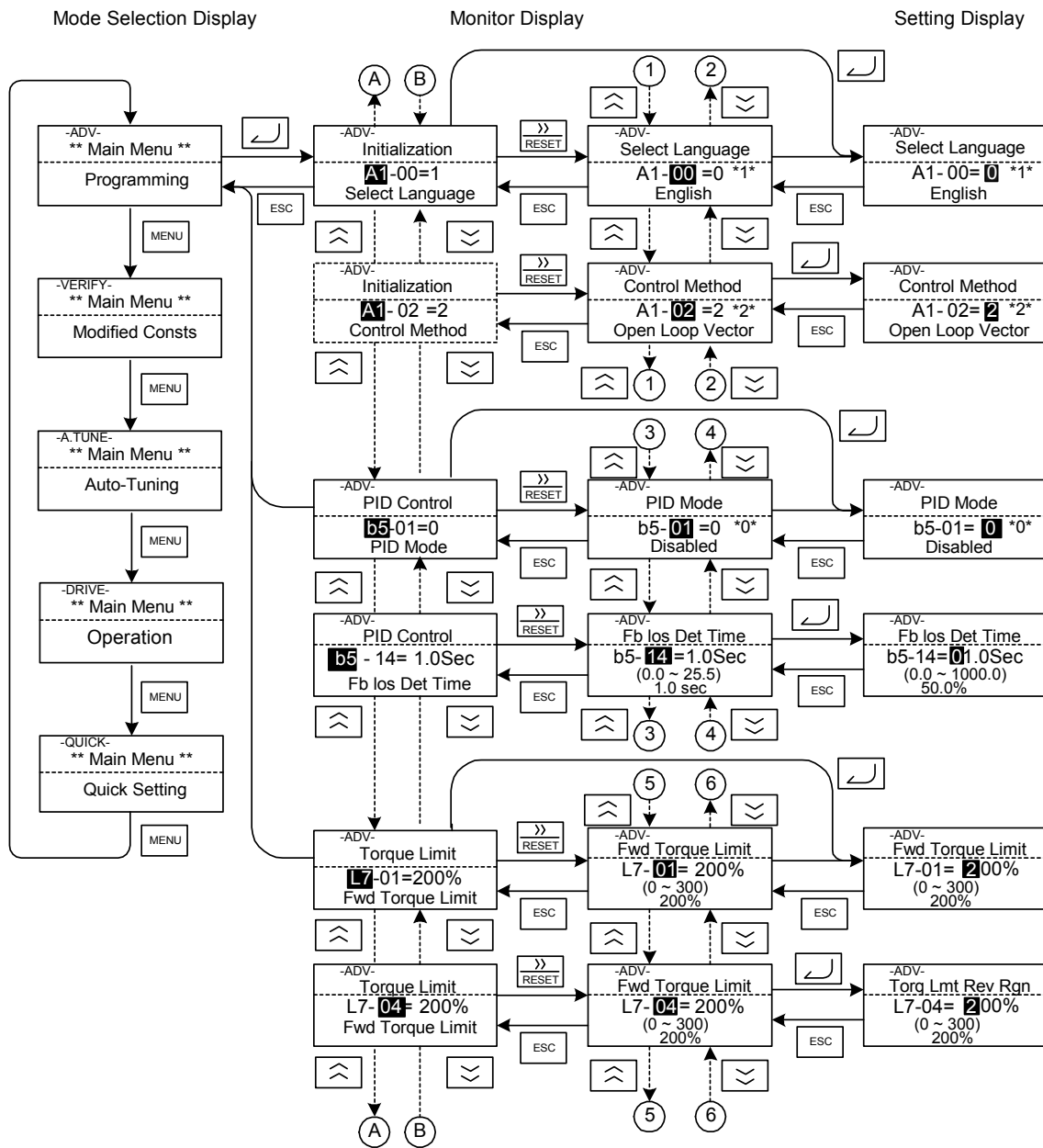

Fig 3.6 Operations in Advanced Programming Mode

■ Setting Parameters

Here the procedure to change C1-01 (Acceleration Time 1) from 10 s to 20 s is shown.

Table 3.3 Setting Parameters in Advanced Programming Mode

Step No.	Digital Operator Display	Description
1	<pre> -DRIVE- Rdy Frequency Ref U1- 01=50.00Hz ----- U1-02=50.00Hz U1-03=10.05A </pre>	Power supply turned ON.
2	<pre> -DRIVE- ** Main Menu ** ----- Operation </pre>	Press the MENU key 3 times to enter the advanced programming mode.
3	<pre> -QUICK- ** Main Menu ** ----- Quick Setting </pre>	
4	<pre> -ADV- ** Main Menu ** ----- Programming </pre>	
5	<pre> -ADV- Initialization ----- A1-00=1 Select Language </pre>	Press the DATA/ENTER to access the monitor display.
6	<pre> -ADV- Accel / Decel ----- C1-00 = 10.0sec Accel Time 1 </pre>	Press the Increment or Decrement key to display the parameter C1-01 (Acceleration Time 1).
7	<pre> -ADV- Accel Time 1 ----- C1-01 = 0010.0sec (0.0 ~ 6000.0) "10.0 sec" </pre>	Press the DATA/ENTER key to access the setting display. The current setting value of C1-01 is displayed.
8	<pre> -ADV- Accel Time 1 ----- C1-01 = 0010.0sec (0.0 ~ 6000.0) "10.0 sec" </pre>	Press the Shift/RESET key to move the flashing digit to the right.
9	<pre> -ADV- Accel Time 1 ----- C1-01 = 0010.0sec (0.0 ~ 6000.0) "10.0 sec" </pre>	Press the Increment key to change set value to 20.00 s.
10	<pre> -ADV- Accel Time 1 ----- C1-01 = 0020.0sec (0.0 ~ 6000.0) "10.0 sec" </pre>	Press the DATA/ENTER key to save the set data.
11	<pre> -ADV- Entry Accepted </pre>	"Entry Accepted" is displayed for 1 sec after pressing the DATA/ENTER key.
12	<pre> -ADV- Accel Time 1 ----- C1-01 = 20.0sec (0.0 ~ 6000.0) "10.0 sec" </pre>	The display returns to the monitor display for C1-01.

◆ Verify Mode

The Verify mode is used to display any parameters that have been changed from their default settings in a programming mode or by autotuning. “None” will be displayed if no settings have been changed.

The parameter A1-02 is the only parameter from the A1-□□ group, which will be displayed in the modified constants list if it has been changed before. The other parameters will not be displayed, even if they are different from the default setting.

In the verify mode, the same procedures can be used to change settings as they are used in the programming mode. Use the Increment, Decrement, and Shift/RESET keys to change a setting. When the DATA/ENTER key is pressed the parameter setting are written and the display returns to the Monitor display.

■ Example Operations

In the example below the following settings have been changed from their default settings:

- b1-01 (Reference Selection)
- C1-01 (Acceleration Time 1)
- E1-01 (Input Voltage Setting)
- E2-01 (Motor Rated Current).

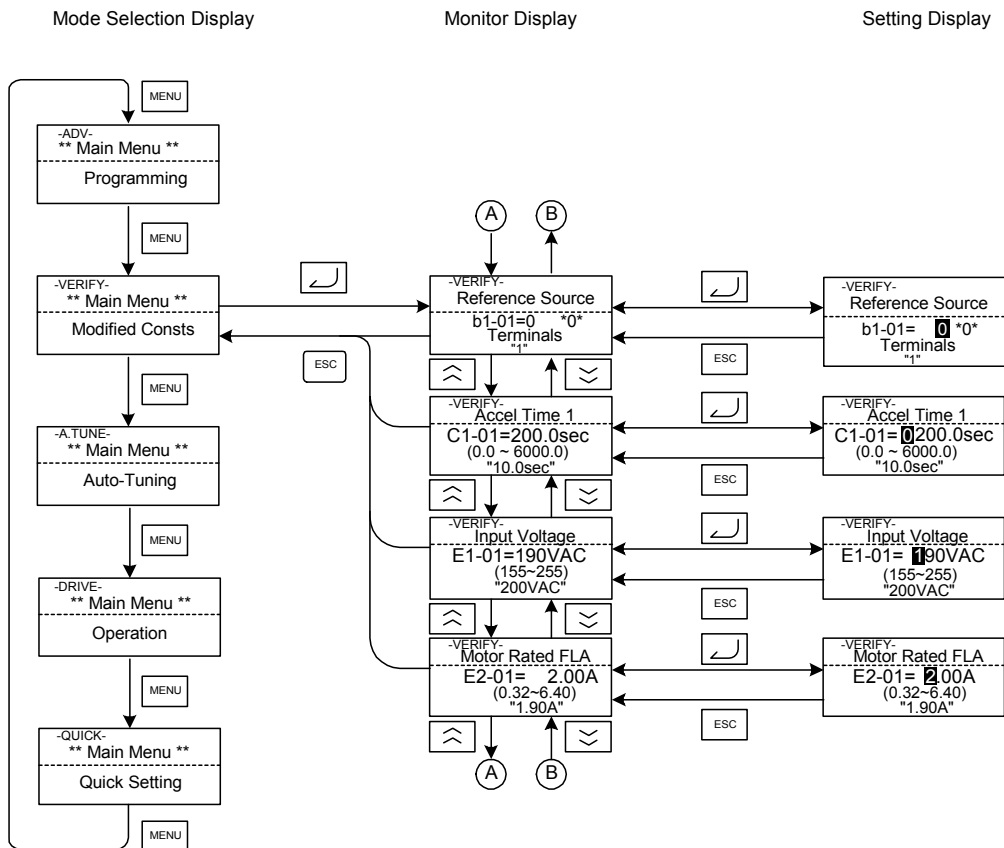

Fig 3.7 Operations in Verify Mode

◆ Autotuning Mode

Autotuning automatically measures and sets the required motor data in order to achieve the maximum performance. Always perform autotuning before starting operation when using the vector control modes.

When V/f control has been selected, only stationary autotuning for line-to-line resistance can be selected.

When the motor cannot be disconnected from the load, and Open Loop or Closed Loop Vector Control shall be used perform stationary autotuning.

■ Example of Operation

Enter the motor rated output power (in kW), rated voltage, rated current, rated frequency, rated speed and number of poles specified on the nameplate of the motor and then press the RUN key. The motor is automatically run and the measured motor data are set in the E2-□□ parameters.

Always set the above items. Otherwise autotuning cannot be started, e.g. it cannot be started from the motor rated voltage input display.

A parameter can be changed from the setting displays using the Increment, Decrement, and Shift/RESET keys. The parameter will be saved when the DATA/ENTER key is pressed.

The following example shows the autotuning input procedure for standard rotating autotuning in Open Loop Vector Control.

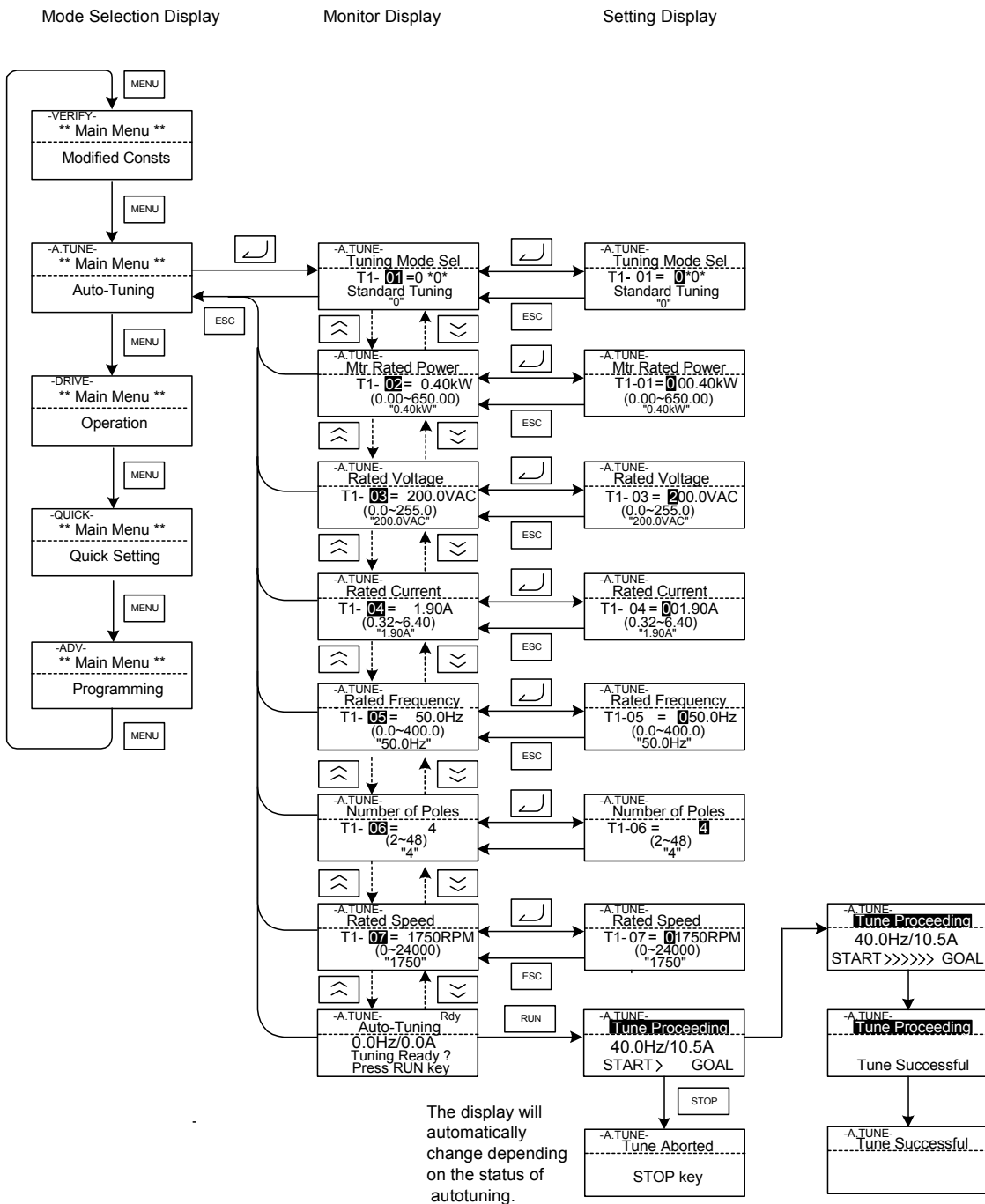

Fig 3.8 Operation in Autotuning Mode

If a fault occurs during autotuning, refer to [Chapter 7 Troubleshooting](#).



4

Trial Operation

This chapter describes the procedures for trial operation of the Inverter and provides an example of trial operation.

Trial Operation Procedure.....	4-2
Trial Operation	4-3
Adjustment Suggestions	4-14

Trial Operation Procedure

Perform trial operation according to the following flowchart. When setting the basic parameters, always set C6-01 (Heavy/Normal Duty Selection) according to the application.

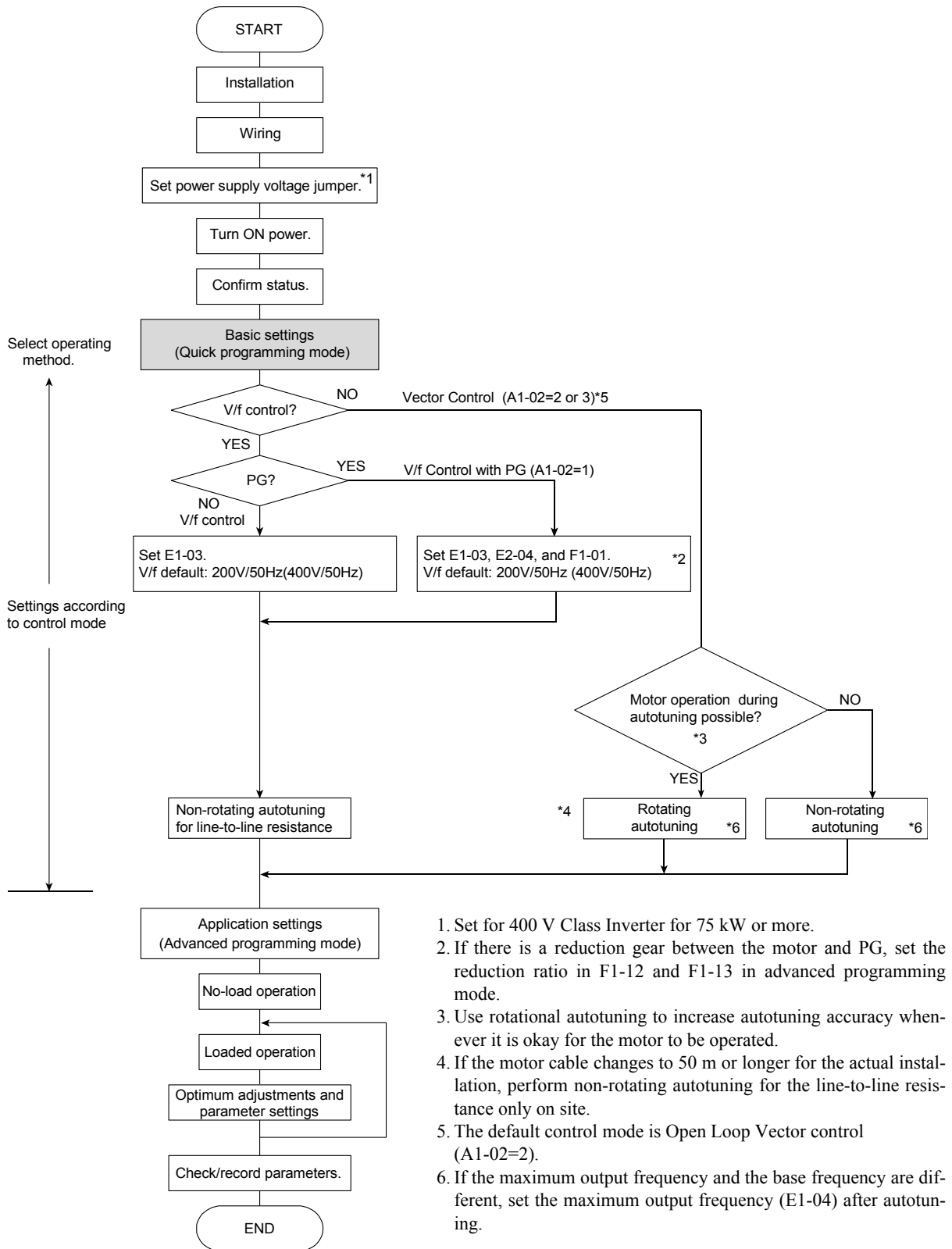

Fig 4.1 Trial Operation Flowchart

◆ Application Confirmation

For applications with quadratic torque characteristic like pumps, fans or blowers set C6-01 (Heavy/Normal Duty selection) to 1 or 2 (Normal Duty 1 or 2). Select the Normal Duty mode (1 or 2) regarding the required overload capability.

For applications with constant torque characteristics like conveyors etc. always set C6-01 to 0 (Heavy Duty). The default setting is of C6-01 is 0 (Heavy Duty).

For details on the Heavy/Normal Duty selection refer to [Chapter 6 Application and Overload Selections](#).

◆ Setting the Power Supply Voltage Jumper (400 V Class Inverters of 75 kW or Higher)

The power supply voltage jumper must be set for 400 V Class Inverters of 75 kW or higher. Insert the jumper into the voltage connector nearest to the actual power supply voltage.

The jumper is factory-set to 440 V. If the power supply voltage is not 440 V, use the following procedure to change the setting.

1. Turn OFF the power supply and wait for at least 5 minutes.
2. Confirm that the CHARGE indicator has gone out.
3. Remove the terminal cover.
4. Insert the jumper at the position for the voltage supplied to the Inverter (see [Fig 4.2](#)).
5. Return the terminal cover to its original position.

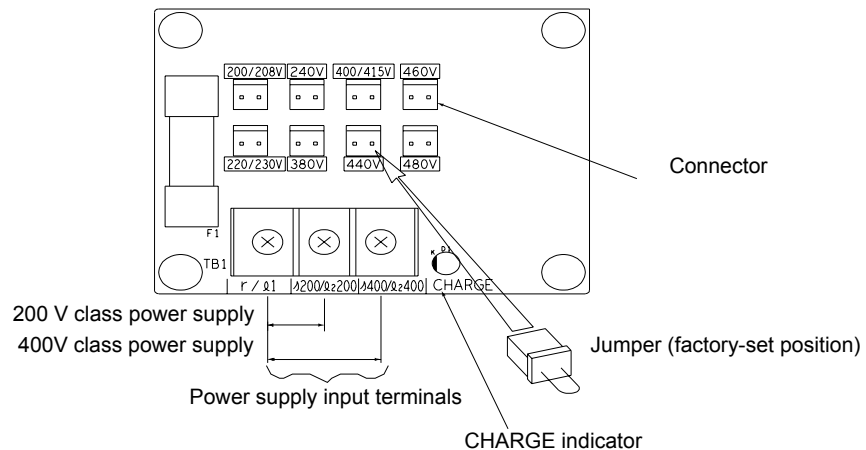

Fig 4.2 Large-capacity Inverter Connections

◆ Power ON

Confirm all of the following items and then turn ON the power supply.

- Check that the power supply is of the correct voltage.
 - 200 V class: 3-phase 200 to 240 VDC, 50/60 Hz
 - 400 V class: 3-phase 380 to 480 VDC, 50/60 Hz
- Make sure that the motor output terminals (U, V, W) and the motor are connected correctly.
- Make sure that the Inverter control circuit terminal and the control device are wired correctly.
- Set all Inverter control circuit terminals to OFF.
- When using a PG Speed Control Card, make sure that it is wired correctly.

◆ Checking the Display Status

After normal power up without any problems the operator display shows the following:

Display for normal operation

```
-DRIVE-      Rdy
Frequency Ref
U1- 01=50.00Hz
-----
U1-02=50.00Hz
U1-03=10.05A
```

The frequency reference monitor is displayed in the data display section.

When a fault has occurred, the details of the fault will be displayed instead of the above display. In that case, refer to [Chapter 7 Troubleshooting](#). The following display shows an example of a display for faulty operation.

Display for fault operation

```
-DRIVE-
      UV
DC Bus Undervolt
```

The display will differ depending on the type of fault.
A low voltage alarm is shown at left.

◆ Basic Settings

Switch to the quick programming mode (“QUICK” will be displayed on the LCD screen) and set the following parameters.

Refer to *Chapter 3 Digital Operator and Modes* for Digital Operator operating procedures and to *Chapter 5 User Parameters* and *Chapter 6 Parameter Settings by Function* for details on the parameters.

Table 4.1 Basic Parameter Settings

● : Must be set. ○ : Set as required.

Class	Parameter Number	Name	Description	Setting Range	Factory Setting	Page
●	A1-02	Control method selection	Sets the control method for the Inverter. 0: V/f control 1: V/f control with PG 2: Open Loop Vector control 3: Closed Loop Vector Control	0 to 3	0	5-7
●	b1-01	Reference selection	Sets the frequency reference input method. 0: Digital Operator 1: Control circuit terminal (analog input) 2: MEMOBUS communications 3: Option Card 4: Pulse train input	0 to 4	1	5-9 6-7 6-64 6-82
●	b1-02	Operation method selection	Sets the run command input method. 0: Digital Operator 1: Control circuit terminal (digital input) 2: MEMOBUS communications 3: Option Card	0 to 3	1	5-9 6-12 6-64 6-82
○	b1-03	Stopping method selection	Selects stopping method when stop command is sent. 0: Deceleration to stop 1: Coast to stop 2: DC braking stop 3: Coast to stop with timer	0 to 3	0	5-9 6-14
●	C1-01	Acceleration time 1	Sets the acceleration time in seconds for the output frequency to climb from 0% to 100%.	0.0 to 6000.0	10.0 s	5-19 6-19
●	C1-02	Deceleration time 1	Sets the deceleration time in seconds for the output frequency to fall from 100% to 0%.	0.0 to 6000.0	10.0 s	5-19 6-19
●	C6-01	Heavy /Normal Duty selection	Set to Heavy Duty or Normal Duty regarding to the applications requirements. 0: Heavy Duty 1: Normal Duty 1 2: Normal Duty 2	0 or 2	0	5-24 6-2
○	C6-02	Carrier frequency selection	Sets the carrier frequency. The factory setting and setting range depends on the setting of C6-01.	0 to F	Depends on setting of C6-01.	5-24
○	d1-01 to d1-16 and d1-17	Frequency references 1 to 16 and jog frequency reference	Sets the required speed references for multi-step speed operation or jogging.	0 to 150.00 Hz *	d1-01 to d1-16: 0.00 Hz d1-17: 6.00 Hz	5-25 6-10

Table 4.1 Basic Parameter Settings (Continued)

● : Must be set. ○ : Set as required.

Class	Parameter Number	Name	Description	Setting Range	Factory Setting	Page
●	E1-01	Input voltage setting	Sets the Inverter's nominal input voltage in volts.	155 to 255 V (200 V class) 310 to 510 V (400 V class)	200 V (200 V class) 400 V (400 V class)	5-30 6-110
●	E2-01	Motor rated current	Sets the motor rated current.	10% to 200% of Inverter's rated current	Setting for general-purpose motor of same capacity as Inverter	5-31 6-48 6-108
○	H4-02 and H4-05	FM and AM terminal output gain	Can be used to adjust the analog output when an instrument is connected to the FM or AM terminal.	0.0 to 1000.0%	H4-02: 100% H4-05: 50%	5-47
●	L1-01	Motor protection selection	Used to enable or disable the motor overload protection function. 0: Disabled 1: Protection for general purpose motor (fan cooled) 2: Protection for frequency converter motor (externally cooled) 3: Protection for special vector control motor	0 to 3	1	5-50 6-48
○	L3-04	Stall prevention selection during deceleration	If using the dynamic brake option (braking resistor, Braking Resistor Units and Braking Units), be sure to set parameter L3-04 to 0 (disabled) or 3 (enabled with braking resistor).	0 to 3	1	5-53 6-24

* The setting range is valid if Heavy Duty is selected (C6-01=0, default setting). If Normal Duty 1 or 2 is selected (C6-01=1 or 2) the setting range will be 0.0 to 400.0 Hz.

◆ Settings for the Control Methods

The usable Autotuning methods depend on the control method setting of the Inverter.

■ Overview of Settings

Make the required settings in quick programming mode and autotuning mode according to [Fig 4.1](#).

■ Setting the Control Method

Select the appropriate control mode as required by the application. [Table 4.2](#) shows the main properties of each control mode.

Table 4.2 Control Mode Properties

Control Mode	Parameter Setting	Basic Control	Main Applications
V/f control	A1-02 = 0	Fixed voltage/frequency ratio control	Variable speed control, particularly control of multiple motors with one Inverter and replacing existing inverters
V/f control with PG	A1-02 = 1	Fixed voltage/frequency ratio control with speed compensation using a PG	Applications requiring high-precision speed control using a PG on the machine side
Open Loop Vector control	A1-02 = 2 (factory setting)	Current vector control without a PG	Variable speed control, applications requiring speed and torque accuracy.
Closed Loop Vector control	A1-02 = 3	Closed Loop Vector control	Very high-performance control with a PG (simple servo drives, high-precision speed control, torque control, and torque limiting)

Note With Open Loop or Closed Loop Vector control, the motor and Inverter must be connected 1:1. The motor capacity for which stable control is possible is 50% to 100% of the Inverters capacity.

V/f Control without PG (A1-02 = 0)

- Set either one a fixed V/f pattern (E1-03=0 to E) or specify a user-set V/f pattern (E1-03=F) as required for the motor and load characteristics using E1-04 to E1-13 in advanced programming mode.

Simple operation of a general-purpose motor at 50 Hz:

E1-03 = 0 or F (default)
If E1-03 = F, the default setting in the user setting from E1-04 to E1-13 are for 00 Hz

Simple operation of a general-purpose motor at 60 Hz:

E1-03 = 1

- Perform non-rotating autotuning for the line-to-line resistance if the motor cable is 50 m or longer for the actual installation or if a heavy load causes motor stalling. Refer to the following section on [Autotuning](#) for details on non-rotating autotuning.

V/f Control with PG (A1-02=1)

Additionally to the V/f control without PG settings the following settings have to be made:

- Set the number of motor poles in E2-04 (Number of Motor Poles)
- Set the number of pulses per rotation in F1-01 (PG Constant). If there is a reduction gear between the motor and PG, set the reduction ratio in F1-12 and F1-13 in advanced programming mode.

Open Loop Vector Control (A1-02 = 2)

Always perform autotuning. If the motor can be operated, perform rotating autotuning. If the motor cannot be operated, perform non-rotating autotuning. Refer to the following section on *Autotuning* for details on autotuning.

Closed Loop Vector Control (A1-02=3)

Always perform autotuning. If the motor can be operated, perform rotating autotuning. If the motor cannot be operated, perform non-rotating autotuning. Refer to the following section on *Autotuning* for details on autotuning.

◆ Autotuning

Autotuning sets motor parameters automatically when using Open Loop or Closed Loop Vector control, when the cable length is long or the installation has changed.

■ Setting the Autotuning Mode

One of the following three autotuning modes can be set.

- Rotating autotuning
- Non-rotating autotuning
- Non-rotating autotuning for line-to-line resistance only

Rotating Autotuning (T1-01 = 0)

Rotating autotuning is used for Open Loop and Closed Loop Vector control only. Set T1-01 to 0, input the data from the motor nameplate, and then press the RUN key on the Digital Operator. The Inverter will operate the motor for approximately 1 minute and set the required motor parameters automatically.

Non-rotating Autotuning (T1-01 = 1)

Non-rotating autotuning is used for Open Loop and Closed Loop Vector control only. Set T1-01 to 1, input the data from the motor nameplate, and then press the RUN key on the Digital Operator. The inverter will supply power to the non-rotating motor for approximately 1 minute and some of the motor parameters will be set automatically. The remaining motor parameters will be set automatically during the first time operation.

Non-rotating Autotuning for Line-to-Line Resistance (T1-01 = 2)

Non-rotating autotuning for line-to-line resistance can be used in any control mode. This is the only possible autotuning for V/f control and V/f control with PG.

It can be used to improve the performance when the motor cable is long, the cable length has changed or when the motor and inverter have different capacities.

To perform autotuning in V/f control or V/f control with PG, set T1-02 (Motor rated power) and T1-04 (Motor rated current) and then press the RUN key on the Digital Operator. The Inverter will supply power to the non-rotating motor for approximately 20 seconds and the Motor line-to-line resistance and cable resistance will be automatically measured.

■ Precautions Before Using Autotuning

Read the following precautions before using autotuning.

- Autotuning an Inverter is fundamentally different from autotuning a servo system. Inverter autotuning automatically adjusts parameters according to detected motor data, whereas servo system autotuning adjusts parameters according to the detected size of the load.
- When speed precision or torque precision is required at high speeds (i.e., 90% of the rated speed or higher), use a motor with a rated voltage that is ~20 V less than the input power supply voltage of the Inverter for 200 V-class Inverters and ~40 V less for 400 V-class Inverters. If the rated voltage of the motor is the same as the input power supply voltage, the voltage output from the Inverter will be unstable at high speeds and sufficient performance will not be possible.
- Use non-rotating autotuning whenever the load cannot be disconnected from the motor.
- Use rotating autotuning whenever performing autotuning when high precision is required or for a motor that is not connected to a load.
- If rotating autotuning is performed for a motor connected to a load, the motor data will not be found accurately and the might be poor. Never perform rotating autotuning for a motor connected to a load.
- If the wiring between the Inverter and motor changes by 50 m or more perform non-rotating autotuning for line-to-line resistance.
- If the motor cable is long (50 m or longer), perform non-rotating autotuning for line-to-line resistance.
- If a mechanical brake is used, make sure that it is *not* opened for non-rotating autotuning. Make sure that it is opened for rotating autotuning.
- Power will be supplied to the motor when non-rotating autotuning is performed even though the motor will not turn. Do not touch the motor until autotuning has been completed.
- The status of the multi-function inputs and multi-function outputs during autotuning will be as shown in the following table.

Tuning Mode	Multi-function Inputs	Multi-function Outputs
Rotating autotuning	Do not work	Same as during normal operation
Non-rotating autotuning	Do not work	Maintain same status as when autotuning is started.
Non-rotating autotuning for line-to-line resistance	Do not work	Maintain same status as when autotuning is started.

- To cancel autotuning, press the STOP key on the Digital Operator.

■Precautions for Rotating and Non-rotating Autotuning

- If the motor rated voltage is higher than the power supply voltage, lower the base voltage value like shown in *Fig 4.3* to prevent saturation of the Inverter's output voltage. Use the following procedure to perform autotuning.

1. Input the voltage of the input power supply to T1-03 (Motor rated voltage).
2. Input the results of the following formula to T1-05 (Motor base frequency):

$$T1-05 = \text{Base frequency from motor nameplate} \times \frac{T1-03}{\text{Motor rated voltage}}$$

3. Perform autotuning.

After the completing autotuning, set E1-04 (Max. output frequency) to the base frequency from the motor's nameplate.

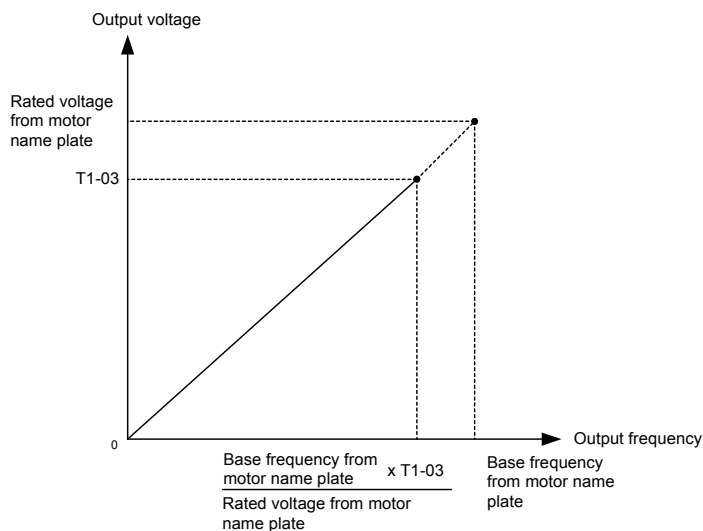

Fig 4.3 Motor Base Frequency and Inverter Input Voltage Setting

- When speed precision is required at high speeds (i.e., 90% of the rated speed or higher), set T1-03 (Motor rated voltage) to the input power supply voltage $\times 0.9$. In this case at high speeds the output current will increase as the input power supply voltage is reduced. Be sure to provide sufficient margin in the Inverter current.

■Precautions after Rotating and Non-rotating Autotuning

If the maximum output frequency and base frequency are different, set the maximum output frequency (E1-04) after autotuning.

Parameter Settings for Autotuning

The following parameters must be set before autotuning.

Table 4.3 Parameter Settings before Autotuning

Parameter Number	Name	Display	Setting Range	Factory Setting	Data Displays during Autotuning			
	Display				V/f	V/f with PG	Open Loop Vector	Closed Loop Vector
T1-00*1	Motor 1/2 selection	Set the location where the autotuned motor data are to be stored. 1: E1 to E2 (motor 1) 2: E3 to E4 (motor 2)	1 or 2	1	Yes	Yes	Yes	Yes
	Select Motor							
T1-01	Autotuning mode selection	Set the autotuning mode. 0: Rotating autotuning 1: Non-rotating autotuning 2: Non-rotating autotuning for line-to-line resistance only	0 to 2	2 (V/f and V/f with PG) 0 (Open Loop Vector)*2	Yes (only 2)	Yes (only 2)	Yes	Yes
	Tuning Mode Sel							
T1-02	Motor rated power	Set the output power of the motor in Kilowatts.	10% to 200% of Inverter rated output *3	Same as Inverter rated output	Yes	Yes	Yes	Yes
	Mtr Rated Power							
T1-03	Motor rated voltage	Set the rated voltage of the motor.*4	0 to 255.0 V (200 V class) 0 to 510.0 V (400 V class)	200.0 V (200 V class) 400.0 V (400 V class)	-	-	Yes	Yes
	Rated Voltage							
T1-04	Motor rated current	Set the rated current of the motor in Amps.	10% to 200% of Inverter rated current *3	Same as general-purpose motor with same capacity as Inverter	Yes	Yes	Yes	Yes
	Rated Current							
T1-05	Motor rated frequency	Set the base frequency of the motor.*4	0 to 150.0 Hz *5	50.0 Hz	-	-	Yes	Yes
	Rated Frequency							
T1-06	Number of motor poles	Set the number of motor poles.	2 to 48 poles	4 poles	-	-	Yes	Yes
	Number of poles							
T1-07	Motor rated speed	Set the base speed of the motor in r/min.	0 to 24000	1750 r/min	-	-	Yes	Yes
	Rated Speed							
T1-08	Number of PG pulses per revolution	Sets the number of pulses for the PG (pulse generator or encoder) per motor revolution without a multiplication factor	0 to 60000	1024	-	Yes	-	Yes
	PG Pulses/Rev							

* 1. Displayed only, when a motor switch command is set for a multi-function digital input (one of H1-01 to H1-05 set to 16).

* 2. Only setting 2 (non-rotating autotuning for line-to-line resistance only) is possible for V/f control or V/f control with PG.

* 3. Stable vector control will be possible when the setting is between 50% and 100%.

* 4. For an inverter motor or vector control motor, the voltage and frequency may be lower than for a general-purpose motor. Always confirm setting on the nameplate or in test reports. Also, if you know the no-load values, set the no-load voltage in T1-03 and the no-load frequency in T1-05 to obtain better accuracy.

* 5. The setting range is valid if Heavy Duty is selected (C6-01=0, default setting). If Normal Duty 1 or 2 is selected (C6-01=1 or 2) the setting range will be 0.0 to 400.0 Hz.

◆ Application Settings

Parameters can be set as required in advanced programming mode (i.e. “ADV” is displayed on the LCD screen). All the parameters which can be set in quick programming mode are also displayed and can be set in the advanced programming mode.

■ Setting Examples

- The following points are examples of settings for applications.
- When using an Inverter-mounted braking resistor (ERF), set L8-01 to 1 to enable ERF braking resistor overheating protection.
- To prevent the machine from being operated in reverse, set b1-04 to 1 to disable reverse operation.
- To increase the speed of a 50 Hz motor by 10%, set E1-04 to 55.0 Hz.
- To use a 0 to 10 V analog signal for a 50 Hz motor for variable-speed operation between 0 and 45 Hz (0% to 90% speed deduction), set H3-02 to 90.0%.
- To limit the speed range between 20% and 80% set d2-01 to 80.0% and set d2-02 to 20.0%.

◆ No-load Operation

This section describes trial operation in which the motor is in no-load state, that means the machine is not connected to the motor. To avoid failures caused by the wiring of the control circuit it is recommended to use the LOCAL mode. Press the LOCAL/REMOTE key on the Digital Operator to change to LOCAL mode (the SEQ and REF indicators on the Digital Operator should be OFF).

Always confirm safety around the motor and machine before starting Inverter operation from the Digital Operator. Confirm that the motor works normally and that no errors are displayed at the Inverter. For applications, at which the machine can be driven in one direction only, check the motor rotation direction.

Operation with Jog frequency reference (d1-17, default: 6.00 Hz) can be started and stopped by pressing and releasing the JOG key on the Digital Operator. If the external control circuit prevents operation from the Digital Operator, confirm that emergency stop circuits and machine safety mechanisms are functioning, and then start operation in REMOTE mode (i.e., with a signal from the control signal terminal). The safety precautions must always be taken before starting the inverter and the motor connected.



NOTE

Both, a RUN command (forward or reverse) and a frequency reference (or multi-step speed command) must be provided to start Inverter operation.

◆ Loaded Operation

■ Connecting the Load

- After confirming that the motor has stopped completely, connect the mechanical system.
- Be sure to tighten all the screws when connecting the motor shaft to the mechanical system.

■ Operation using the Digital Operator

- Use the Digital Operator to start operation in LOCAL mode in the same way as in no-load operation.
- If fault occurs during operation, make sure that the STOP key on the Digital Operator is accessible easily.
- At first, set the frequency reference to a low speed, e.g. to one tenth of the normal operating speed.

■ Checking Operating Status

- Having checked that the operating direction is correct and that the machine is operating smoothly at slow speed, increase the frequency reference.
- After changing the frequency reference or the rotation direction, check that there is no oscillation or abnormal sound from the motor. Check the monitor display to ensure that U1-03 (Output Current) is not too high.
- Refer to [Table 4.4](#) if hunting, vibration, or other problems originated by the control system occur.

◆ Check and Recording Parameters

Use the verify mode (“VERIFY” is displayed on the LCD screen) to check parameters that have been changed for trial operation and record them in a parameter table.

Any parameters that have been changed by autotuning will also be displayed in the verify mode.

If required, the copy function in parameters o3-01 and o3-02 displayed in advanced programming mode can be used to copy the changed settings from the inverter to a recording area in the Digital Operator. If changed settings are saved in the Digital Operator, they can be easily copied back to the Inverter to speed up system recovery if for any reason the inverter has to be replaced.

The following functions can also be used to manage parameters.

- Saving user initial parameter values
- Setting access levels for parameters
- Setting a password

■ Saving User Initial Parameter Values (o2-03)

- If o2-03 is set to 1 after completing trial operation, the settings of parameters will be saved in a separate memory area in the inverter. When the Inverter settings have been changed for any reason, the parameters can be initialized to the settings saved in the separate memory area by setting A1-03 (Initialize) to 1110.

■ Parameter Access Levels (A1-01)

- A1-01 can be set to 0 (monitoring-only) to prevent parameters from being changed. A1-01 can also be set to 1 (User-specified Parameters) to display only parameters required by the machine or application in a programming mode. These parameters can be determined by setting the A2-XX parameters.

■ Password (A1-04 and A1-05)

- When the access level is set to monitoring-only (A1-01 = 0), a password can be set so that parameters will be displayed only when the correct password has been input.

Adjustment Suggestions

If hunting, vibration, or other problems originated in the control system occur during trial operation, adjust the parameters listed in the following table according to the control method. This table lists the most commonly used parameters only.

Table 4.4 Adjusted Parameters

Control Method	Name (Parameter Number)	Influence	Factory Setting	Recommended Setting	Adjustment Method
V/f control (A1-02 = 0 or 1)	Hunting-prevention gain (N1-02)	Controlling hunting and vibration in middle-range speeds (10 to 40 Hz)	1.00	0.50 to 2.00	<ul style="list-style-type: none"> Reduce the setting if torque is insufficient for heavy loads. Increase the setting if hunting or vibration occurs for light loads.
	Carrier frequency selection (C6-02)	<ul style="list-style-type: none"> Reducing motor magnetic noise Controlling hunting and vibration at low speeds 	Depends on capacity	0 to default	<ul style="list-style-type: none"> Increase the setting if motor magnetic noise is high. Reduce the setting if hunting or vibration occurs at low to middle-range speeds.
	Torque compensation primary delay time constant (C4-02)	<ul style="list-style-type: none"> Increasing torque and speed response Controlling hunting and vibration 	Depends on capacity	200 to 1000 ms	<ul style="list-style-type: none"> Reduce the setting if torque or speed response is low. Increase the setting if hunting or vibration occurs.
	Torque compensation gain (C4-01)	<ul style="list-style-type: none"> Improving torque at low speeds (10 Hz or lower) Controlling hunting and vibration 	1.00	0.50 to 1.50	<ul style="list-style-type: none"> Increase the setting if torque is insufficient at low speeds. Reduce the setting if hunting or vibration occurs for light loads.
	Middle output frequency voltage (E1-08) Minimum output frequency voltage (E1-10)	<ul style="list-style-type: none"> Improving torque at low speeds Controlling shock at startup 	Depends on capacity and voltage	Default to Default + 5 V*	<ul style="list-style-type: none"> Increase the setting if torque is insufficient at low speeds. Reduce the setting if the shock at startup is large.
Open Loop Vector control (A1-02 = 2)	Speed feedback detection control (AFR) gain (N2-01)	<ul style="list-style-type: none"> Increasing torque and speed response Controlling hunting and vibration in middle-range speeds (10 to 40 Hz) 	1.00	0.50 to 2.00	<ul style="list-style-type: none"> Reduce the setting if torque or speed response is low. Increase the setting if hunting or vibration occurs.
	Torque compensation primary delay time constant (C4-02)	<ul style="list-style-type: none"> Increasing torque and speed response Controlling hunting and vibration 	20 ms	20 to 100 ms	<ul style="list-style-type: none"> Reduce the setting if torque or speed response is low. Increase the setting if hunting or vibration occurs.
	Slip compensation primary delay time (C3-02)	<ul style="list-style-type: none"> Increasing speed response Improving speed stability 	200 ms	100 to 500 ms	<ul style="list-style-type: none"> Reduce the setting if speed response is low. Increase the setting if the speed is not stable.
	Slip compensation gain (C3-01)	<ul style="list-style-type: none"> Improving speed accuracy 	1.0	0.5 to 1.5	<ul style="list-style-type: none"> Increase the setting if speed response is low. Reduce the setting if the speed is too high.

Table 4.4 Adjusted Parameters (Continued)

Control Method	Name (Parameter Number)	Influence	Factory Setting	Recommended Setting	Adjustment Method
Open Loop Vector control (A1-02 = 2)	Carrier frequency selection (C6-02)	<ul style="list-style-type: none"> Reducing motor magnetic noise Controlling hunting and vibration at low speeds (10 Hz or less) 	Depends on capacity	0 to default	<ul style="list-style-type: none"> Increase the setting if motor magnetic noise is high. Reduce the setting if hunting or vibration occurs at low speeds.
	Middle output frequency voltage (E1-08) Minimum output frequency voltage (E1-10)	<ul style="list-style-type: none"> Improving torque at low speeds Controlling shock at startup 	Depends on capacity and voltage	Default to Default + 5 V*	<ul style="list-style-type: none"> Increase the setting if torque or speed response is low. Reduce the setting if shock at startup is large.
Closed Loop Vector control (A1-02 = 3)	ASR proportional gain 1 (C5-01) and ASR proportional gain 2 (C5-03)	<ul style="list-style-type: none"> Torque and speed response Controlling hunting and vibration 	20.00	10.00 to 50.00	<ul style="list-style-type: none"> Increase the setting if torque or speed response is low. Reduce the setting if hunting or vibration occurs.
	ASR integral time 1 (high-speed) (C5-02) and ASR integral time 2 (low-speed) (C5-04)	<ul style="list-style-type: none"> Torque and speed response Controlling hunting and vibration 	0.500 s	0.300 to 1.000 s	<ul style="list-style-type: none"> Reduce the setting if torque or speed response is low. Increase the setting if hunting or vibration occurs.
	ASR switching frequency (C5-07)	Switching the ASR proportional gain and integral time according to the output frequency	0.0 Hz	0.0 to max. output frequency	Sets the output frequency at which to change the ASR proportional gain and integral time when the same values cannot be used for high-speed and low-speed operation.
	ASR primary delay time (C5-06)	<ul style="list-style-type: none"> Controlling hunting and vibration 	0.004 s	0.004 to 0.020	Increase the setting if machine rigidity is low and the system vibrates easily.
	Carrier frequency selection (C6-02)	<ul style="list-style-type: none"> Reducing motor magnetic noise Controlling hunting and vibration at low speeds (3 Hz or less) 	Depends on the capacity.	2.0 kHz to default	<ul style="list-style-type: none"> Increase the setting if motor magnetic noise is too high. Reduce the setting if hunting or vibration occurs at very low to middle-range speeds.

* The setting is given for 200 V Class Inverters. Double the voltage for 400 V Class Inverters.

- Do not change the Torque Compensation Gain (C4-01) from its default setting of 1.00 when using Open Loop Vector control.
- If speeds are inaccurate during regeneration in Open Loop Vector control, enable Slip Compensation during regeneration (C3-04 = 1).
- Use slip compensation to improve speed control during V/f control (A1-02 = 0). Set the Motor Rated Current (E2-01), Motor Rated Slip (E2-02), and Motor No-load Current (E2-03), and then adjust the Slip Compensation Gain (C3-01) between 0.5 and 1.5. The default setting for V/f control is C3-01 = 0.0 (slip compensation disabled).
- To improve speed response and stability in V/f control with a PG (A1-02 = 1), set the ASR parameters (C5-01 to C5-05) to between 0.5 and 1.5 times the default value. (Normally it is not necessary to adjust this setting.)

The following parameters will also affect the control system indirectly.

Table 4.5 Parameters Which Affect Control and Applications Indirectly

Name (Parameter Number)	Application
Heavy/Normal Duty selection (C6-01)	Sets the maximum torque and overload capability.
DWELL function (b6-01 to b6-04)	Used for heavy loads or large machine backlashes.
Acceleration/deceleration times (C1-01 to C1-11)	By adjusting the acceleration and deceleration times the torque is influenced indirectly.
S-curve characteristics (C2-01 to C2-04)	Used to prevent shock at the acceleration/deceleration start and end.
Jump frequencies (d3-01 to d3-04)	Used to avoid continuous operation at possible machine resonance frequencies.
Analog input filter time constant (H3-12)	Used to prevent fluctuations in analog input signals caused by noise.
Stall prevention (L3-01 to L3-06)	Used to prevent OV (overvoltage errors) and motor stalling for heavy loads or rapid acceleration/deceleration. Stall prevention is enabled by default and the setting normally has not to be changed. When using a braking resistor disable the stall prevention during deceleration by setting L3-04 to 0 or set it to 3 (enabled with braking resistor).
Torque limits (L7-01 to L7-04)	Sets the maximum torque during Open Loop and Closed Loop Vector control. If a setting is reduced too much, stalling can occur under heavy loads.
Feed forward control (N5-01 to N5-03)	Used to increase response for acceleration/deceleration or to reduce overshooting when there is low machine rigidity and the gain of the speed controller (ASR) cannot be increased. The inertia ratio between the load and motor and the acceleration time of the motor running unloaded must be set.



5

User Parameters

This chapter describes all user parameters that can be set in the Inverter.

User Parameter Descriptions.....	5-2
Digital Operation Display Functions and Levels	5-3
User Parameter Tables.....	5-7

User Parameter Descriptions

This section describes the contents of the user parameter tables.

◆ Description of User Parameter Tables

User parameter tables are structured as shown below. Here, b1-01 (Frequency Reference Selection) is used as an example.

Parameter Number	Name	Description	Setting Range	Factory Setting	Change during Operation	Control Methods				MEMO-BUS Register	Page
	Display					V/f	V/f with PG	Open Loop Vector	Closed Loop Vector		
b1-01	Reference selection	Sets the frequency reference input method. 0: Digital Operator 1: Control circuit terminal (analog input) 2: MEMOBUS communications 3: Option Card 4: Pulse train input	0 to 4	1	No	Q	Q	Q	Q	180H	-

- Parameter Number: The number of the user parameter.
- Name: The name of the user parameter.
- Description: Details on the function or settings of the user parameter.
- Setting Range: The setting range for the user parameter.
- Factory Setting: The factory setting (each control method has its own factory setting. Therefore the factory setting changes when the control method is changed.)
Refer to page [page 5-70, Factory Settings that Change with the Control Method \(A1-02\)](#) for factory settings that are changed by setting the control method.
- Change during Operation: Indicates whether the parameter can be changed or not while the Inverter is in operation.
Yes: Changes are possible during operation.
No: Changes are not possible during operation.
- Control Methods: Indicates the control methods in which the user parameter can be monitored or set.
Q: The item can be monitored and set as well in quick programming mode as in advanced programming mode.
A: The item can be monitored and set in advanced programming mode only.
No: The item cannot be monitored or set in this control method.
- MEMOBUS Register: The register number used for MEMOBUS communications.
- Page: Reference page for more detailed information about the parameter.

Digital Operation Display Functions and Levels

The following figure shows the Digital Operator display hierarchy for the Inverter.

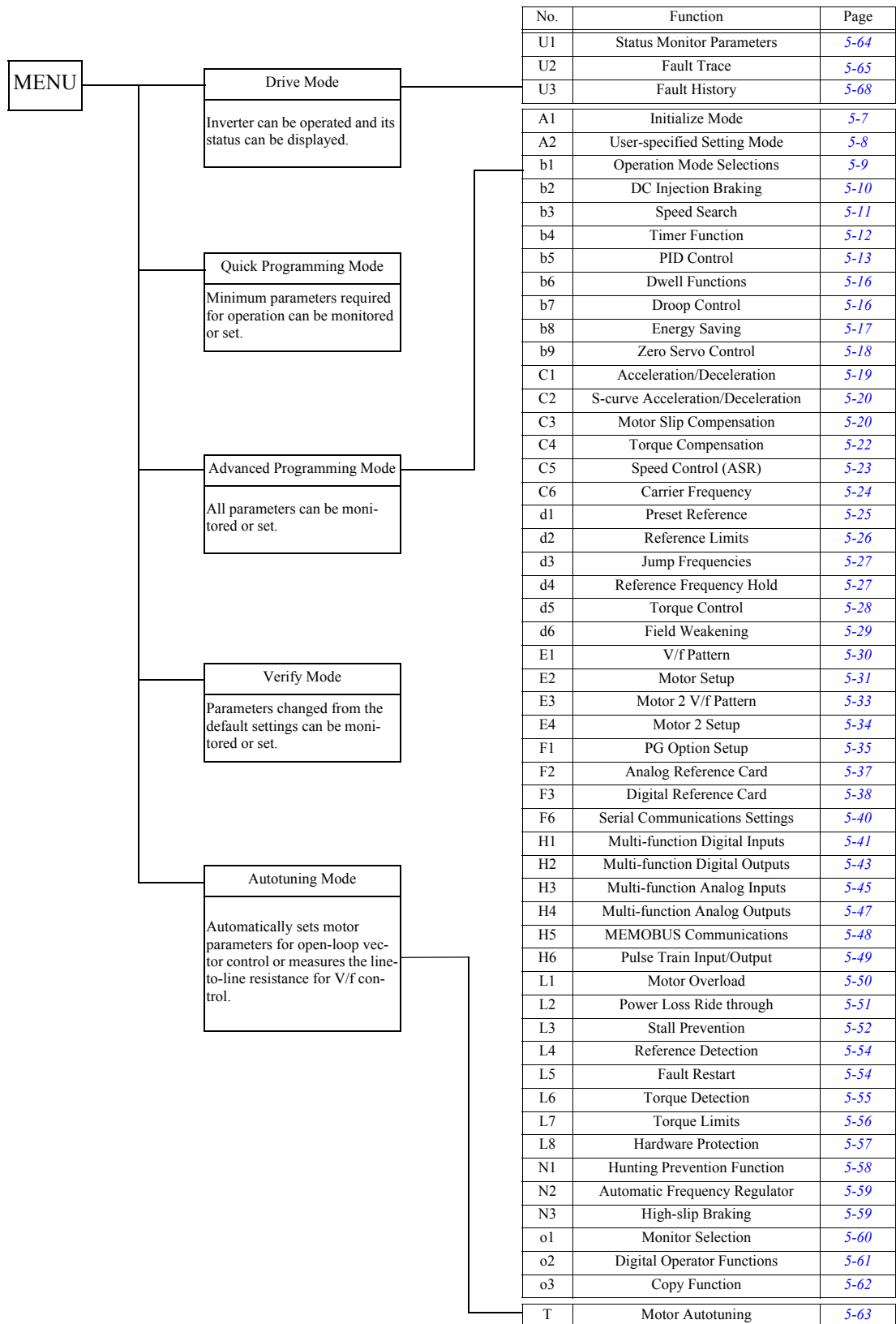

◆ User Parameters Available in Quick Programming Mode

The minimum user parameters required for Inverter operation can be monitored and set in quick programming mode. The user parameters displayed in quick programming mode are listed in the following table. These, and all other user parameters, are also displayed in advanced programming mode.

Parameter Number	Name	Description	Setting Range	Factory Setting	Change during Operation	Control Methods				MEMO BUS Register
	Display					V/f	V/f with PG	Open Loop Vector	Closed Loop Vector	
A1-02	Control method selection	Sets the control method for the Inverter. 0: V/f control 1: V/f control with PG 2: Open-Loop Vector control 3: Closed Loop Vector control	0 to 3	2	No	Q	Q	Q	Q	102H
	Control Method									
b1-01	Reference source selection	Sets the frequency reference input method. 0: Digital Operator 1: Control circuit terminal (analog input) 2: MEMOBUS communications 3: Option Card 4: Pulse train input	0 to 4	1	No	Q	Q	Q	Q	180H
	Reference Source									
b1-02	RUN source selection	Sets the run command input method 0: Digital Operator 1: Control circuit terminal (digital multi function inputs) 2: MEMOBUS communications 3: Option Card	0 to 3	1	No	Q	Q	Q	Q	181H
	Run Source									
b1-03	Stopping method selection	Select stopping method when stop command is input. 0: Deceleration to stop 1: Coast to stop 2: DC braking stop (Stops faster than coast to stop, without regenerative operation.) 3: Coast to stop with timer (Run commands are disregarded during deceleration time.)	0 to 3	0	No	Q	Q	Q	Q	182H
	Stopping Method									
C1-01	Acceleration time 1	Sets the acceleration time to accelerate from 0 Hz to the maximum output frequency.	0.0 to 6000.0 *1	10.0 s	Yes	Q	Q	Q	Q	200H
	Accel Time 1									
C1-02	Deceleration time 1	Sets the deceleration time to decelerate from the maximum output frequency to 0 Hz.								201H
	Decel Time 1									
C6-01	Heavy/Normal Duty selection	0: Heavy Duty 1: Normal Duty 1 2: Normal Duty 2	0 or 2	0	No	Q	Q	Q	Q	223H
	Heavy/Normal Duty									
C6-02	Carrier frequency selection	Selects the carrier frequency. Select F to enable detailed settings using parameters C6-03 to C6-05.	0 to F	1	No	Q	Q	Q	Q	224H
	Carrier Freq Sel									

Parameter Number	Name	Description	Setting Range	Factory Setting	Change during Operation	Control Methods				MEMO BUS Register
	Display					V/f	V/f with PG	Open Loop Vector	Closed Loop Vector	
d1-01	Frequency reference 1	Sets the master frequency reference.		0.00 Hz	Yes	Q	Q	Q	Q	280H
	Reference 1									
d1-02	Frequency reference 2	Sets the frequency reference when multi-step speed command 1 is ON for a multi-function input.		0.00 Hz	Yes	Q	Q	Q	Q	281H
	Reference 2									
d1-03	Frequency reference 3	Sets the frequency reference when multi-step speed command 2 is ON for a multi-function input.	0 to 150.00 *2	0.00 Hz	Yes	Q	Q	Q	Q	282H
	Reference 3									
d1-04	Frequency reference 4	Sets the frequency reference when multi-step speed command 1 and 2 are ON for a multi-function input.		0.00 Hz	Yes	Q	Q	Q	Q	283H
	Reference 4									
d1-17	Jog frequency reference	Sets the frequency reference when multi-function inputs „Jog Frequency Command“, „FJOG command“, or „RJOG command“ is ON.		6.00 Hz	Yes	Q	Q	Q	Q	292H
	Jog Reference									
E1-01	Input voltage setting	Sets the inverter input voltage. This set value will be the basis for the protection functions.	155 to 255 *3	230 V *3	No	Q	Q	Q	Q	300H
	Input Voltage									
E1-03	V/f pattern selection	0 to E: Select from 15 preset patterns. F: Custom user-set pattern (Applicable for the setting of E1-04 to E1-10).	0 to F	F	No	Q	Q	No	Q	302H
	V/f Selection									
E1-04	Max. output frequency (FMAX)		40.0 to 150.0 *2	50.0Hz	No	Q	Q	Q	Q	303H
	Max Frequency									
E1-05	Max. voltage (VMAX)		0.0 to 255.0 *3	200.0 V *3	No	Q	Q	Q	Q	304H
	Max Voltage									
E1-06	Base frequency (FA)		0.0 to 150.0 *2	50.0Hz *4	No	Q	Q	Q	Q	305H
	Base Frequency									
E1-09	Min. output frequency (FMIN)		0.0 to 150.0 *2	0.5 Hz *4	No	Q	Q	Q	Q	308H
	Min Frequency									
E1-13	Base voltage (VBASE)	Sets the output voltage at the base frequency (E1-06).	0.0 to 255.0 *3	0.0 V *5	No	A	A	Q	Q	30CH
	Base Voltage									
E2-01	Motor rated current	Sets the motor rated current in Amps. This set value becomes the base value for motor protection and torque limit. It is an input data for autotuning.	0.32 to 6.40 *5	1.90 A *6	No	Q	Q	Q	Q	30EH
	Mtr Rated Power									
E2-04	Number of motor poles	Sets the number of motor poles. It is an input data for autotuning.	2 to 48	4	No	No	Q	No	Q	311H
	Number of Poles									

Parameter Number	Name	Description	Setting Range	Factory Setting	Change during Operation	Control Methods				MEMO BUS Register
	Display					V/f	V/f with PG	Open Loop Vector	Closed Loop Vector	
F1-01	PG constant	Sets the number of PG pulses (pulse generator or encoder).	0 to 60000	1024	No	No	Q	No	Q	380H
	PG Pulses/Rev									
H4-02	Gain (terminal FM)	Sets the multi-function analog output 1 (terminal FM) gain.	0 to 1000%	100%	Yes	Q	Q	Q	Q	41EH
	Terminal FM Gain	Sets the percentage of the monitor item that is equal to 10V/20mA output at terminal FM. Note that the maximum output voltage/current is 10V/20mA.								
H4-05	Gain (terminal AM)	Sets the multi-function analog output 2 (terminal AM) gain.	0 to 1000%	50%	Yes	Q	Q	Q	Q	421H
	Terminal AM Gain	Sets the percentage of the monitor item that is equal to 10V/20mA output at terminal AM. Note that the maximum output voltage/current is 10V/20mA.								
L1-01	Motor protection selection	Set to enable or disable the motor overload protection function using the electronic thermal relay. 0: Disabled	0 to 3	1	No	Q	Q	Q	Q	480H
	MOL Select	1: Protection for general purpose motor (fan cooled) 2: Protection for frequency converter motor (external cooled) 3: Protection for special vector control motor When the inverter power supply is turned off, the thermal value is reset, so even if this parameter is set to 1, protection may not be effective. When several motors are connected to one Inverter, set to 0 and ensure that each motor is equipped with a protection device.								
L3-04	Stall prevention selection during deceleration	0: Disabled (Deceleration as set. If deceleration time is too short, a main circuit overvoltage may result.) 1: Enabled (Deceleration is stopped when the DC bus voltage exceeds the stall prevention level. Deceleration restarts when voltage falls below the stall level again.)	0 to 3	1	No	Q	Q	Q	Q	492H
	StallP Decel Sel	2: Intelligent deceleration mode (Deceleration rate is automatically adjusted so that in Inverter can decelerate in the shortest possible time. The set deceleration time is disregarded.) 3: Enabled (with Braking Resistor Unit) When a braking option (Braking Resistor, Braking Resistor Unit, Braking Unit) is used, always set to 0 or 3.								

- * 1. The setting ranges for acceleration/deceleration times depends on the setting of C1-10 (Acceleration/deceleration Time Setting Unit). If C1-10 is set to 0, the setting range is 0.00 to 600.00 (s).
- * 2. The given setting range is valid if Heavy Duty is selected (C6-01=0, default setting). If Normal Duty 1 or 2 is selected (C6-01=1 or 2) the setting range will be 0.0 to 400.0 Hz.
- * 3. These are values for a 200 V class Inverter. Values for a 400 V class Inverter are double.
- * 4. The factory setting will change when the control method is changed. (Open Loop Vector control factory settings are given.)
- * 5. After autotuning, E1-13 will contain the same value as E1-05.
- * 6. The factory setting depends on the Inverter capacity. (The value for a 200 V Class Inverter for 0.4 kW is given.)
- * 7. The setting range is from 10% to 200% of the Inverter rated output current. (The value for a 200 V Class Inverter for 0.4 kW is given.)

User Parameter Tables

◆ A: Setup Settings

■ Initialize Mode: A1

Parameter Number	Name	Description	Setting Range	Factory Setting	Change during Operation	Control Methods				MEMO-BUS Register	Page
	Display					V/f	V/f with PG	Open Loop Vector	Closed Loop Vector		
A1-00	Language selection for Digital Operator display	Used to select the language displayed on the Digital Operator (JVOP-160 only). 0: English 1: Japanese 2: German 3: French 4: Italian 5: Spanish 6: Portuguese This parameter is not changed by the initialize operation.	0 to 6	0	Yes	A	A	A	A	100H	-
	Select Language										
A1-01	Parameter access level	Used to set the parameter access level (set/read.) 0: Monitoring only (Monitoring drive mode and setting A1-01 and A1-04.) 1: Used to select user parameters (Only parameters set in A2-01 to A2-32 can be read and set.) 2: Advanced (Parameters can be read and set in both, quick programming mode (Q) and advanced programming mode (A).)	0 to 2	2	Yes	A	A	A	A	101H	6-136
	Access Level										
A1-02	Control method selection	Used to select the control method for the Inverter 0: V/f control 1: V/f with PG feedback 2: Open loop vector 3: Closed Loop Vector This parameter is not changed by the initialize operation.	0 to 3	2	No	Q	Q	Q	Q	102H	4-5 4-7 4-14
	Control Method										
A1-03	Initialize	Used to initialize the parameters using the specified method. 0: No initializing 1110: Initializes using the user parameters 2220: Initializes using a two-wire sequence. (Initializes to the factory setting.) 3330: Initializes using a three-wire sequence.	0 to 3330	0	No	A	A	A	A	103H	-
	Init Parameters										

Parameter Number	Name	Description	Setting Range	Factory Setting	Change during Operation	Control Methods				MEMO-BUS Register	Page
	Display					V/f	V/f with PG	Open Loop Vector	Closed Loop Vector		
A1-04	Password	Password input when a password has been set in A1-05. This function write-protects some parameters of the initialize mode. If the password is changed, A1-01 to A1-03 and A2-01 to A2-32 parameters can no longer be changed. (Programming mode parameters can be changed.)	0 to 9999	0	No	A	A	A	A	104H	6-136
	Enter Password										
A1-05	Password setting	Used to set a four digit number as the password. Usually this parameter is not displayed. When the Password (A1-04) is displayed, hold down the RESET key and press the Menu key. The password will be displayed.	0 to 9999	0	No	A	A	A	A	105H	6-136
	Select Password										

■ User-set Parameters: A2

Parameter Number	Name	Description	Setting Range	Factory Setting	Change during Operation	Control Methods				MEMO-BUS Register	Page
	Display					V/f	V/f with PG	Open Loop Vector	Closed Loop Vector		
A2-01 to A2-32	User specified parameters User Param 1 to 32	Used to select the function for each of the user specified parameters. User parameters are the only accessible parameters if Parameter Access Level is set to user parameters (A1-01=1)	b1-01 to o3-02	–	No	A	A	A	A	106H to 125H	6-137

◆ Application Parameters: b

■ Operation Mode Selections: b1

Parameter Number	Name		Description	Setting Range	Factory Setting	Change during Operation	Control Methods				MEMO-BUS Register	Page
	Display						V/f	V/f with PG	Open Loop Vector	Closed Loop Vector		
b1-01	Reference source selection		Sets the frequency reference input method. 0: Digital Operator 1: Control circuit terminal (analog input) 2: MEMOBUS communications 3: Option Card 4: Pulse train input	0 to 4	1	No	Q	Q	Q	Q	180H	4-5 6-7 6-64
	Reference Source											
b1-02	RUN command source selection		Sets the run command input method. 0: Digital Operator 1: Control circuit terminal (digital multi function inputs) 2: MEMOBUS communications 3: Option Card	0 to 3	1	No	Q	Q	Q	Q	181H	4-5 6-12 6-64
	Run Source											
b1-03	Stopping method selection		Used to set the stopping method used when a stop command is input. 0: Deceleration to stop 1: Coast to stop 2: DC injection braking stop (Stops faster than coast to stop, no regenerative operation.) 3: Coast to stop with timer (Run commands are disregarded during deceleration.)	0 to 3 *1	0	No	Q	Q	Q	Q	182H	4-5 6-14
	Stopping Method											
b1-04	Prohibition of reverse operation		0: Reverse enabled 1: Reverse disabled 2: Output Phase Rotation (both rotational directions are enabled)	0 to 2 *2	0	No	A	A	A	A	183H	6-51
	Reverse Oper						A	No	A	No		
b1-05	Operation selection for setting frequencies equal or lower than E1-09		Used to set the method of operation when the frequency reference input is less than the minimum output frequency (E1-09). 0: Run at frequency reference (E1-09 not effective). 1: STOP (coast to stop) 2: Run at min. frequency. (E1-09) 3: Run at zero speed (Frequencies below E1-09 are zero)	0 to 3	0	No	No	No	No	A	184H	6-14
	Zero-Speed Oper											
b1-06	Control input scan		Used to set the responsiveness of the control inputs (forward/reverse and multi-function inputs.) 0: Fast reading 1: Normal reading (Can be used for possible malfunction due to noise.)	0 or 1	1	No	A	A	A	A	185H	-
	Cntl Input Scans											

Parameter Number	Name	Description	Setting Range	Factory Setting	Change during Operation	Control Methods				MEMO-BUS Register	Page
	Display					V/f	V/f with PG	Open Loop Vector	Closed Loop Vector		
b1-07	Operation selection after switching to remote mode	Used to set the operation mode when switching to the Remote mode using the Local/Remote Key. 0: Run signals that are input during mode switching are disregarded. (Input Run signals after switching the mode.) 1: Run signals become effective immediately after switching to the Remote mode.	0 or 1	0	No	A	A	A	A	186H	-
	LOC/REM RUN Sel										
b1-08	Run command selection in programming modes	Used to set an operation prohibition in programming modes. 0: Operation prohibited. 1: Operation permitted (Disabled when Digital Operator is the selected Run command source (b1-02 = 0)).	0 or 1	0	No	A	A	A	A	187H	-
	RUN CMD at PRG										

- * 1. The setting range is 0 or 1 for Closed Loop Vector control.
- * 2. The setting range is 0 or 1 for Closed Loop Vector control an V/f control with PG

5 ■DC Injection Braking: b2

Parameter Number	Name	Description	Setting Range	Factory Setting	Change during Operation	Control Methods				MEMO-BUS Register	Page
	Display					V/f	V/f with PG	Open Loop Vector	Closed Loop Vector		
b2-01	Zero speed level (DC injection braking starting frequency)	Used to set the frequency at which DC injection braking starts when b1-03 is set to 0 (deceleration to stop). When b2-01 is less than E1-09, E1-09 becomes the DC injection braking starting frequency.	0.0 to 10.0	0.5 Hz	No	A	A	A	A	189H	6-14 6-17
	DCInj Start Freq										
b2-02	DC injection braking current	Sets the DC injection braking current as a percentage of the inverter rated current.	0 to 100	50%	No	A	A	A	A	18AH	6-14 6-17
	DCInj Current										
b2-03	DC injection braking time at start	Used to set the time to perform DC injection braking at start in units of 1 second. Used to stop coasting motor and restart it. When the set value is 0, DC injection braking at start is not performed.	0.00 to 10.00	0.00 s	No	A	A	A	A	18BH	6-17
	DCInj Time@Start										
b2-04	DC injection braking time at stop	Used to set the time to perform DC injection braking at stop in units of 1 second. Used to prevent coasting after the stop command has been input. When the set value is 0.00, DC injection braking at stop is not performed.	0.00 to 10.00	0.50 s	No	A	A	A	A	18CH	6-14 6-17
	DCInj Time@Stop										

■Speed Search: b3

Parameter Number	Name	Description	Setting Range	Factory Setting	Change during Operation	Control Methods				MEMO-BUS Register	Page
	Display					V/f	V/f with PG	Open Loop Vector	Closed Loop Vector		
b3-01	Speed search selection (current detection or speed calculation)	<p>Enables/disables the speed search function for the RUN command and sets the speed search method.</p> <p>0: Disabled, speed calculation 1: Enabled, speed calculation 2: Disabled, current detection 3: Enabled, current detection</p> <p>Speed Calculation: When the search is started, the motor speed is calculated and acceleration/deceleration is performed from the calculated speed to the specified frequency (motor direction is also searched).</p> <p>Current Detection: The speed search is started from the frequency when power was momentarily lost or the maximum frequency. The speed is detected by observing the current.</p>	0 to 3	2*	No	A	A	A	No	191H	6-53
	SpdSrCh at Start										
b3-02	Speed search operating current (current detection)	<p>Sets the speed search operation current as a percentage, taking the Inverter rated current as 100%. Usually not necessary to set. When restarting is not possible with the factory settings, reduce the value.</p>	0 to 200	100%*	No	A	No	A	No	192H	6-53
	SpdSrCh Current										
b3-03	Speed search deceleration time (current detection)	<p>Sets the output frequency deceleration time during speed search in 1-second units.</p> <p>Sets the time for deceleration from the maximum output frequency to the minimum output frequency.</p>	0.1 to 10.0	2.0 s	No	A	No	A	No	193H	6-53
	SpdSrCh Dec Time										
b3-05	Speed search wait time (current detection or speed calculation)	<p>When a speed search is performed after recovering from a momentary power loss, the search operation is delayed for the time set here.</p> <p>If e.g. a contactor is used at the output side of the inverter set this parameter to the contactor delay time or more.</p>	0.0 to 20.0	0.2 s	No	A	A	A	A	195H	6-53
	Search Delay										
b3-10	Speed Search Compensation Gain (speed calculation only)	<p>Sets the gain, which is applied to the estimated speed before the motor is restarted.</p>	1.00 to 1.20	1.10	No	A	No	No	No	19AH	6-53
	Srch Detect Comp										

Parameter Number	Name	Description	Setting Range	Factory Setting	Change during Operation	Control Methods				MEMO-BUS Register	Page
	Display					V/f	V/f with PG	Open Loop Vector	Closed Loop Vector		
b3-14	Speed Search Rotating Selection Direction	0: Speed Search is started using the rotation direction from the frequency reference signal	0 or 1	1	No	A	A	A	No	19EH	6-53
	Bidir Search Sel	1: Speed Search is started using the rotation direction from the estimated speed during speed search.									

* The factory setting will change when the control method is changed. (Open Loop Vector factory settings are given.)

■Timer Function: b4

Parameter Number	Name	Description	Setting Range	Factory Setting	Change during Operation	Control Methods				MEMO-BUS Register	Page
	Display					V/f	V/f with PG	Open Loop Vector	Closed Loop Vector		
b4-01	Timer function ON-delay time	Sets the timer function output ON-delay time (dead time) for the timer function input.	0.0 to 3000.0	0.0 s	No	A	A	A	A	1A3H	6-95
	Delay-ON Timer	Enabled when a timer function is set in H1-□□ and H2-□□.									
b4-02	Timer function OFF-delay time	Sets the timer function output OFF-delay time (dead band) for the timer function input.	0.0 to 3000.0	0.0 s	No	A	A	A	A	1A4H	6-95
	Delay-OFF Timer	Enabled when a timer function is set in H1-□□ and H2-□□.									

■PID Control: b5

Parameter Number	Name	Description	Setting Range	Factory Setting	Change during Operation	Control Methods				MEMO-BUS Register	Page
	Display					V/f	V/f with PG	Open Loop Vector	Closed Loop Vector		
b5-01	PID control mode selection	0: Disabled 1: Enabled (Deviation is D-controlled.) 2: Enabled (Feedback value is D-controlled.) 3: PID control enabled (frequency reference + PID output, D control of deviation) 4: PID control enabled (frequency reference + PID output, D control of feedback value).	0 to 4	0	No	A	A	A	A	1A5H	6-96
	PID Mode										
b5-02	Proportional gain (P)	Sets P-control proportional gain. P-control is not performed when the setting is 0.00.	0.00 to 25.00	1.00	Yes	A	A	A	A	1A6H	6-96
	PID Gain										
b5-03	Integral (I) time	Sets I-control integral time. I-control is not performed when the setting is 0.0.	0.0 to 360.0	1.0 s	Yes	A	A	A	A	1A7H	6-96
	PID I Time										
b5-04	Integral (I) limit	Sets the I-control limit as a percentage of the maximum output frequency.	0.0 to 100.0	100.0%	Yes	A	A	A	A	1A8H	6-96
	PID I Limit										
b5-05	Differential (D) time	Sets D-control differential time. D-control is not performed when the setting is 0.00.	0.00 to 10.00	0.00 s	Yes	A	A	A	A	1A9H	6-96
	PID D Time										
b5-06	PID limit	Sets the limit after PID-control as a percentage of the maximum output frequency.	0.0 to 100.0	100.0%	Yes	A	A	A	A	1AAH	6-96
	PID Limit										
b5-07	PID offset adjustment	Sets the offset after PID-control as a percentage of the maximum output frequency.	-100.0 to +100.0	0.0%	Yes	A	A	A	A	1ABH	6-96
	PID Offset										
b5-08	PID delay time constant	Sets the time constant for low pass filter for PID-control output. Usually not necessary to set.	0.00 to 10.00	0.00 s	Yes	A	A	A	A	1ACH	6-96
	PID Delay Time										
b5-09	PID output characteristics selection	Selects forward/reverse direction for PID output. 0: Normal PID output 1: Reverse PID output	0 or 1	0	No	A	A	A	A	1ADH	6-96
	Output Level Sel										
b5-10	PID output gain	Sets output gain.	0.0 to 25.0	1.0	No	A	A	A	A	1AEH	6-96
	Output Gain										
b5-11	PID reverse output selection	0: Limit to 0 when PID output is negative. 1: Reverses when PID output is negative. Limit to 0 is also active when reverse prohibit is selected by using b1-04.	0 or 1	0	No	A	A	A	A	1AFH	6-96
	Output Rev Sel										

Parameter Number	Name	Description	Setting Range	Factory Setting	Change during Operation	Control Methods				MEMO-BUS Register	Page
	Display					V/f	V/f with PG	Open Loop Vector	Closed Loop Vector		
b5-12	Selection of PID feedback signal loss detection	0: No detection of a feedback loss. 1: Detection of a feedback loss. (feedback under detection level) Operation continues during detection, the fault contact is not operated. 2: Detection of a feedback loss. (feedback under detection level) The motor coasts to stop at detection, and the fault contact operates. 3: Detection of a feedback loss. (feedback over detection level) Operation continues during detection, the fault contact is not operated. 4: Detection of a feedback loss. (feedback over detection level) The motor coasts to stop at detection, and the fault contact operates.	0 to 4	0	No	A	A	A	A	1B0H	6-96
	Fb Los Det Sel										
b5-13	PID feedback loss detection level	Sets the PID feedback loss detection level as a percentage using the maximum output frequency as 100%.	0 to 100	0%	No	A	A	A	A	1B1H	6-96
	Fb los Det Lvl										
b5-14	PID feedback loss detection time	Sets the PID feedback loss detection time.	0.0 to 25.5	1.0 s	No	A	A	A	A	1B2H	6-96
	Fb los Det Time										
b5-15	PID sleep function operation level	Sets the PID sleep function start level as a frequency.	0.0 to 150.0 *	0.0 Hz	No	A	A	A	A	1B3H	6-96
	PID Sleep Level										
b5-16	PID sleep operation delay time	Sets the delay time until the PID sleep function starts.	0.0 to 25.5	0.0 s	No	A	A	A	A	1B4H	6-96
	PID Sleep Time										
b5-17	Accel/decel time for PID reference	Sets the accel/decel time for PID reference.	0.0 to 6000.0	0.0 s	No	A	A	A	A	1B5H	6-96
	PID Acc/Dec Time										
b5-18	PID Set-point Selection	0: Disabled 1: Enabled	0 to 1	0	No	A	A	A	A	1DCH	6-96
	PID Set-point Sel										

Parameter Number	Name	Description	Setting Range	Factory Setting	Change during Operation	Control Methods				MEMO-BUS Register	Page
	Display					V/f	V/f with PG	Open Loop Vector	Closed Loop Vector		
b5-19	PID Setpoint	PID-target value	0 to 100.0%	0	No	A	A	A	A	1DDH	6-96
	PID Setpoint										
b5-28	PID Square Root Feedback Sel	Enables/Disables the square root function for the PID feedback 0: Disabled 1: Enabled	0 or 1	0	No	A	A	A	A	1EAH	6-96
	PID Fd SqRt										
b5-29	Square root Feedback Gain	Sets the gain for the PID square root feedback function.	0.00 to 2.00	1.00	No	A	A	A	A	1EBH	6-96
	PID Fd SqRt Gain										
b5-31	PID feedback monitor selection	Selects one of the inverters monitor items (U1-□□) as PID feedback signal. The setting number is equal to the monitor item which has to be the feedback value.	0 to 18	0	No	A	A	A	A	1EDH	6-96
	PID Fb Mon Sel										
b5-32	PID monitor feedback gain	Sets the gain for the PID feedback signal.	0.0 to 1000.0	100.0%	No	A	A	A	A	1EEH	6-96
	PID Fb Mon Gain										
b5-33	PID monitor feedback bias	Sets the bias for the PID feedback value	-100.0 to 100.0	0.0%	No	A	A	A	A	1EFH	6-96
	PID Fb Mon Bias										

* The given setting range is valid if Heavy Duty is selected (C6-01=0, default setting). If Normal Duty 1 or 2 is selected (C6-01=1 or 2) the setting range will be 0.0 to 400.0 Hz.

■ Dwell Functions: b6

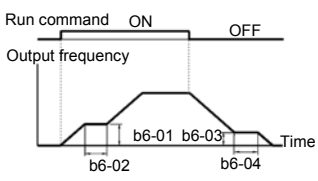
Parameter Number	Name	Description	Setting Range	Factory Setting	Change during Operation	Control Methods				MEMO-BUS Register	Page
	Display					V/f	V/f with PG	Open Loop Vector	Closed Loop Vector		
b6-01	Dwell frequency at start	 <p>The dwell function can be used to hold the output frequency temporarily when driving a motor with a heavy load.</p>	0.0 to 150.0 *	0.0 Hz	No	A	A	A	A	1B6H	6-22
	Dwell Ref @ Start										
b6-02	Dwell time at start		0.0 to 10.0	0.0 s	No	A	A	A	A	1B7H	6-22
	Dwell Time @ Start										
b6-03	Dwell frequency at stop		0.0 to 150.0 *	0.0 Hz	No	A	A	A	A	1B8H	6-22
	Dwell Ref @ Stop										
b6-04	Dwell time at stop		0.0 to 10.0	0.0 s	No	A	A	A	A	1B9H	6-22
	Dwell Time @ Stop										

* The given setting range is valid if Heavy Duty is selected (C6-01=0, default setting). If Normal Duty 1 or 2 is selected (C6-01=1 or 2) the setting range will be 0.0 to 400.0 Hz

■ Droop Control: b7

Parameter Number	Name	Description	Setting Range	Factory Setting	Change during Operation	Control Methods				MEMO-BUS Register	Page
	Display					V/f	V/f with PG	Open Loop Vector	Closed Loop Vector		
b7-01	Droop Control Gain	Sets the Droop quantity at the rated speed and rated load as percentage of the maximum output frequency.	0.0 to 100.0	0.0%	Yes	No	No	No	A	1CAH	6-124
	Droop Quantity										
b7-02	Droop Control Delay Time	Sets the Droop Control delay time constant. Increase the value if hunting occurs.	0.03 to 2.00	0.05 s	No	No	No	No	A	1CBH	6-124
	Droop Delay Time										

■ Energy Saving: b8

Parameter Number	Name	Description	Setting Range	Factory Setting	Change during Operation	Control Methods				MEMO-BUS Register	Page
	Display					V/f	V/f with PG	Open Loop Vector	Closed Loop Vector		
b8-01	Energy-saving mode selection	Select whether to enable or disable energy-saving control. 0: Disable 1: Enable	0 or 1	0	No	A	A	A	A	1CCH	6-106
	Energy Save Sel										
b8-02	Energy-saving gain	Sets the energy-saving gain for Open Loop and Closed Loop Vector control.	0.0 to 10.0	0.7 *1	Yes	No	No	A	A	1CDH	6-106
	Energy Save Gain										
b8-03	Energy-saving filter time constant	Sets the energy-saving filter time constant for Open Loop and Closed Loop Vector control.	0.00 to 10.0	0.50 s *2	Yes	No	No	A	A	1CEH	6-106
	Energy Save F.T										
b8-04	Energy-saving coefficient	Sets the energy-saving coefficient depending on the setting in E2-11 (motor rated current). Adjust the value in 5% steps until the output power becomes minimal.	0.0 to 655.00	*3	No	A	A	No	No	1CFH	6-106
	Energy Save COEF										
b8-05	Power detection filter time constant	Sets the time constant for output power detection.	0 to 2000	20 ms	No	A	A	No	No	1D0H	6-106
	kW Filter Time										
b8-06	Search operation voltage limiter	Sets the limit of the voltage control range during search operation. 100% is the motor rated voltage.	0 to 100	0%	No	A	A	No	No	1D1H	6-106
	Search V Limit										

* 1. The factory setting is given for Open Loop Vector control. The Closed Loop Vector control factory setting is 1.0.

* 2. The factory setting is 2.00 s when Inverter capacity is 55 kW min.

* 3. The factory settings depend on the Inverter capacity.

■Zero Servo Control: b9

Parameter Number	Name	Description	Setting Range	Factory Setting	Change during Operation	Control Methods				MEMO-BUS Register	Page
	Display					V/f	V/f with PG	Open Loop Vector	Closed Loop Vector		
b9-01	Zero Servo Gain	Adjust the strength of the zero-servo lock.	0 to 100	5	No	No	No	No	A	1DAH	6-125
	Zero Servo Gain	Enabled when the “zero-servo command” is set for a multi-function input. When the zero-servo command has been input and the frequency reference drops below DC Injection level (b2-01), a position control loop is created and the motor stops. Increasing the zero-servo gain increases the strength of the lock. Increasing it by much causes oscillations.									
b9-02	Zero-Servo completion bandwidth	Sets the bandwidth of the Zero Servo completion output.	0 to 16383	10	No	No	No	No	A	1DBH	6-125
	Zero Servo Count	Enabled when the “zero-servo completion (end)” is set for a multi-function output. The zero-servo completion signal is ON when the current position is within the range (the zero-servo position + zero-servo completion width.) Set b9-02 to 4 times of the allowable displacement pulse amount at the PG.									

◆ Tuning Parameters: C

■ Acceleration/Deceleration: C1

Parameter Number	Name	Description	Setting Range	Factory Setting	Change during Operation	Control Methods				MEMO-BUS Register	Page																																				
	Display					V/f	V/f with PG	Open Loop Vector	Closed Loop Vector																																						
C1-01	Acceleration time 1	Sets the acceleration time to accelerate from 0 Hz to the maximum output frequency.	0.0 to 6000.0 *1	10.0 s	Yes	Q	Q	Q	Q	200H	4-5 6-19																																				
	Accel Time 1																																														
C1-02	Deceleration time 1	Sets the deceleration time to decelerate from the maximum output frequency to 0 Hz.										0.0 to 6000.0 *1	10.0 s	Yes	Q	Q	Q	Q	201H	4-5 6-19																											
	Decel Time 1																																														
C1-03	Acceleration time 2	Sets the acceleration time when the multi-function input “accel/ decel time 1” is set to ON.																			0.0 to 6000.0 *1	10.0 s	Yes	A	A	A	A	202H	6-19																		
	Accel Time 2																																														
C1-04	Deceleration time 2	Sets the deceleration time when the multi-function input “accel/ decel time 1” is set to ON.																												0.0 to 6000.0 *1	10.0 s	Yes	A	A	A	A	203H	6-19									
	Decel Time 2																																														
C1-05	Acceleration time 3	Sets the acceleration time when the multi-function input “accel/ decel time 2” is set to ON.																																					0.0 to 6000.0 *1	10.0 s	No	A	A	A	A	204H	6-19
	Accel Time 3																																														
C1-06	Deceleration time 3	Sets the deceleration time when the multi-function input “accel/ decel time 2” is set to ON.																																													
	Decel Time 3																																														
C1-07	Acceleration time 4	Sets the acceleration time when the multi-function input “accel/ decel time 1” and “accel/ decel time 2” are set to ON.	0.0 to 6000.0 *1	10.0 s	No	A	A	A	A	206H	6-19																																				
	Accel Time 4																																														
C1-08	Deceleration time 4	Sets the deceleration time when the multi-function input “accel/ decel time 1” and “accel/ decel time 2” are set to ON.										0.0 to 6000.0 *1	10.0 s	No	A	A	A	A	207H	6-19																											
	Decel Time 4																																														
C1-09	Emergency stop time	Sets the deceleration time when the multi-function input “Emergency (fast) stop” is set to ON.																			0.0 to 6000.0 *1	10.0 s	No	A	A	A	A	208H	6-19																		
	Fast Stop Time																																														
C1-10	Accel/dec time setting unit	0: 0.01-second units 1: 0.1-second units																												0 or 1	1	No	A	A	A	A	209H	6-19									
	Acc/Dec Units																																														
C1-11	Accel/dec time switching frequency	Sets the frequency for automatic acceleration/deceleration switching. If the output frequency is below the set frequency: Accel/ decel time 4 If the output frequency is above the set frequency: Accel/decel time 1 The multi-function input “accel/ decel time 1” or “accel/ decel time 2” has priority.																																					0.0 to 150.0 *2	0.0 Hz	No	A	A	A	A	20AH	6-19
	Acc/Dec SW Freq																																														

* 1. The setting range for acceleration/deceleration times will depend on the setting for C1-10. When C1-10 is set to 0, the setting range for acceleration/ deceleration times becomes 0.00 to 600.00 seconds.

* 2. The given setting range is valid if Heavy Duty is selected (C6-01=0, default setting). If Normal Duty 1 or 2 is selected (C6-01=1 or 2) the setting range will be 0.0 to 400.0 Hz

■ S-Curve Acceleration/Deceleration: C2

Parameter Number	Name	Description	Setting Range	Factory Setting	Change during Operation	Control Methods				MEMO-BUS Register	Page	
	Display					V/f	V/f with PG	Open Loop Vector	Closed Loop Vector			
C2-01	S-curve characteristic time at acceleration start	<p>When the S-curve characteristic time is set, the accel/decel times will increase by only half of the S-curve characteristic times at start and end.</p> $T_{\text{accel}} = \frac{C2-01}{2} + C1-01 + \frac{C2-02}{2}$ $T_{\text{decel}} = \frac{C2-03}{2} + C1-02 + \frac{C2-04}{2}$	0.00 to 2.50	0.20 s	No	A	A	A	A	20BH	6-21	
	SCrv Acc @ Start											
C2-02	S-curve characteristic time at acceleration end			0.00 to 2.50	0.20 s	No	A	A	A	A	20CH	6-21
	SCrv Acc @ End											
C2-03	S-curve characteristic time at deceleration start		0.00 to 2.50	0.20 s	No	A	A	A	A	20DH	6-21	
	SCrv Dec @ Start											
C2-04	S-curve characteristic time at deceleration end		0.00 to 2.50	0.00 s	No	A	A	A	A	20EH	6-21	
	SCrv Dec @ End											

■ Motor Slip Compensation: C3

Parameter Number	Name	Description	Setting Range	Factory Setting	Change during Operation	Control Methods				MEMO-BUS Register	Page
	Display					V/f	V/f with PG	Open Loop Vector	Closed Loop Vector		
C3-01	Slip compensation gain	<p>Used to improve speed accuracy when operating with a load. Usually changing this setting is not necessary. Adjust this parameter under the following circumstances.</p> <ul style="list-style-type: none"> When motor speed is lower than the frequency reference increase the set value. When motor speed is higher than the frequency reference decrease the set value. 	0.0 to 2.5	1.0*	Yes	A	No	A	No	20FH	4-14 6-33
	Slip Comp Gain										

Parameter Number	Name	Description	Setting Range	Factory Setting	Change during Operation	Control Methods				MEMO-BUS Register	Page
	Display					V/f	V/f with PG	Open Loop Vector	Closed Loop Vector		
C3-02	Slip compensation delay time	Sets the Slip Compensation delay time. Usually changing this setting is not necessary.	0 to 10000	200 ms *	No	A	No	A	No	210H	4-14 6-33
	Slip Comp Time	Adjust this parameter under the following circumstances. <ul style="list-style-type: none"> Reduce the setting when Slip Compensation responsiveness is low. When speed is not stable, increase the setting. 									
C3-03	Slip compensation limit	Sets the slip compensation limit as a percentage of motor rated slip.	0 to 250	200%	No	A	No	A	No	211H	6-33
	Slip Comp Limit										
C3-04	Slip compensation selection during regeneration	0: Disabled. 1: Enabled. When the slip compensation during regeneration function has been activated and regeneration capacity increases momentarily, it might be necessary to use a braking option (braking resistor, braking resistor unit or braking unit.)	0 or 1	0	No	A	No	A	No	212H	6-33
	Slip Comp Regen										
C3-05	Output voltage limit operation selection	0: Disabled. 1: Enabled. (The motor flux will be lowered automatically when the output voltage become saturated.)	0 or 1	0	No	No	No	A	A	213H	6-33
	V/f Slip Comp Sel										

* The factory setting will change when the control method is changed. (The Open Loop Vector control factory settings are given.)

■ Torque Compensation: C4

Parameter Number	Name	Description	Setting Range	Factory Setting	Change during Operation	Control Methods				MEMO-BUS Register	Page
	Display					V/f	V/f with PG	Open Loop Vector	Closed Loop Vector		
C4-01	Torque compensation gain	<p>Sets the torque compensation gain. Usually changing this setting is not necessary. Adjust it under the following circumstances:</p> <ul style="list-style-type: none"> When the cable is long increase the set value. When the motor capacity is smaller than the Inverter capacity (Max. applicable motor capacity), increase the set values. When the motor is oscillating, decrease the set values. <p>Adjust the torque compensation gain so that at minimum speed the output current does not exceed the Inverter rated output current. Do not alter the torque compensation gain from its default (1.00) when using Open Loop Vector control.</p>	0.00 to 2.50	1.00	Yes	A	A	A	No	215H	4-14 6-35
	Torq Comp Gain										
C4-02	Torque compensation delay time constant	<p>The torque compensation delay time is set in ms units. Usually changing this setting is not necessary. Adjust it under the following circumstances:</p> <ul style="list-style-type: none"> When the motor is oscillating, increase the set values. When the responsiveness of the motor is low, decrease the set values. 	0 to 10000	20 ms *	No	A	A	A	No	216H	4-14 6-35
	Torq Comp Time										
C4-03	Starting torque compensation (FWD)	Sets the torque compensation value at start in FWD direction	0.0 to 200.0%	0.0%	No	No	No	A	No	217H	6-35
	FTorqCmp @ Start										
C4-04	Starting torque compensation (REV)	Sets the torque compensation value at start in REV direction	-200.0 to 0.0%	0.0%	No	No	No	A	No	218H	6-35
	RTorqCmp @ Start										
C4-05	Starting torque compensation time constant	Sets starting torque start-up time. When 0 ~ 4 ms is set, it is operated without filter.	0 to 200	10 ms	No	No	No	A	No	219H	6-35
	TorqCmp-DelayT										

* The factory setting will change when the control method is changed. (Open Loop Vector control factory settings are given.)

■Speed Control (ASR): C5

Parameter Number	Name	Description	Setting Range	Factory Setting	Change during Operation	Control Methods				MEMO-BUS Register	Page
	Display					V/f	V/f with PG	Open Loop Vector	Closed Loop Vector		
C5-01	ASR proportional (P) gain 1	Sets the proportional gain of the speed loop (ASR)	0.00 to 300.00 *1	20.00 *2	Yes	No	A	No	A	21BH	6-36
	ASR P Gain 1										
C5-02	ASR integral (I) time 1	Sets the integral time of the speed loop (ASR).	0.000 to 10.000	0.500 s *2	Yes	No	A	No	A	21CH	6-36
	ASR I Time 1										
C5-03	ASR proportional (P) gain 2	Usually changing this setting is not necessary.	0.00 to 300.00 *1	20.00 *2	Yes	No	A	No	A	21DH	6-36
	ASR P Gain 2										
C5-04	ASR integral (I) time 2		0.000 to 10.000	0.500 s *2	Yes	No	A	No	A	21EH	6-36
	ASR I Time 2										
C5-05	ASR limit	Sets the upper limit for the compensation frequency for the speed control loop (ASR) as a percentage of the maximum output frequency.	0.0 to 20.0	5.0%	No	No	A	No	No	21FH	6-36
	ASR Limit										
C5-06	ASR delay time	Sets the filter time constant; the time from the speed loop to the torque command output. Usually changing this setting is not necessary.	0.000 to 0.500	0.004 ms	No	No	No	No	A	220H	6-36
	ASR Delay Time										
C5-07	ASR switching frequency	Sets the frequency for switching between Proportion Gain 1, 2 and Integral Time 1, 2.	0.0 to 150.0 *3	0.0 Hz	No	No	No	No	A	221H	6-36
	ASR Gain SW Freq										
C5-08	ASR integral (I) limit	Set the parameter to a small value to prevent any radical load change. A setting of 100% is equal to the maximum output frequency.	0 to 400	400%	No	No	No	No	A	222H	6-36
	ASR I Limit										

* 1. The setting range is 1.00 to 300.00 if Closed Loop Vector control is used.

* 2. When the control method is changed, these values are reset to factory settings for the selected control mode. (The Closed Loop Vector control factory settings are given)

* 3. The given setting range is valid if Heavy Duty is selected (C6-01=0, default setting). If Normal Duty 1 or 2 is selected (C6-01=1 or 2) the setting range will be 0.0 to 400.0 Hz

Carrier Frequency: C6

Parameter Number	Name	Description	Setting Range	Factory Setting	Change during Operation	Control Methods				MEMO-BUS Register	Page
	Display					V/f	V/f with PG	Open Loop Vector	Closed Loop Vector		
C6-01	Heavy/Normal Duty selection	0: Heavy Duty 1: Normal Duty 1 2: Normal Duty 2	0 to 2	0	No	Q	Q	Q	Q	223H	4-5 6-2
	Heavy/Normal Duty										
C6-02	Carrier frequency selection	Selects the carrier frequency. Select F to enable detailed settings using parameters C6-03 to C6-05. 0: Low carrier, low noise 1: 2 kHz 2: 5 kHz 3: 8 kHz 4: 10 kHz 5: 12.5 kHz 6: 15 kHz F: User setting	0 to F	1	No	Q	Q	Q	Q	224H	4-5 4-14 6-2
	Carrier Freq Sel										
C6-03	Carrier frequency upper limit	Sets the carrier frequency upper limit and lower limit in kHz units. The carrier frequency gain is set as follows: In the Open Loop and Closed Loop Vector control, the upper limit of the carrier frequency is fixed with C6-03.	2.0 to 15.0 *1 *2	2.0 kHz	No	A	A	A	A	225H	6-2
	Carrier Freq Max										
C6-04	Carrier frequency lower limit	Carrier frequency	0.4 to 15.0 *1 *2	2.0 kHz	No	A	A	No	No	226H	6-2
	Carrier Freq Gain										
C6-05	Carrier frequency proportional gain	<p>Output frequency x (C6-05) x Output frequency</p>	00 to 99 *2	00	No	A	A	No	No	227H	6-2
	Carrier Freq Sel										

* 1. The setting range depends on the capacity of the Inverter.

* 2. This parameter can be monitored or set only when 1 is set for C6-01 and F is set for C6-02.

◆ Reference Parameters: d

■ Preset Reference: d1

Parameter Number	Name	Description	Setting Range	Factory Setting	Change during Operation	Control Methods				MEMO-BUS Register	Page																												
	Display					V/f	V/f with PG	Open Loop Vector	Closed Loop Vector																														
d1-01	Frequency reference 1	Sets the frequency reference.	0 to 50.00 *1*2	0.00 Hz	Yes	Q	Q	Q	Q	280H	4-5 6-10																												
	Reference 1																																						
d1-02	Frequency reference 2	Sets the frequency reference when multi-step speed command 1 is ON for a multi-function input.									0.00 Hz	Yes	Q	Q	Q	Q	281H	4-5 6-10																					
	Reference 2																																						
d1-03	Frequency reference 3	Sets the frequency reference when multi-step speed command 2 is ON for a multi-function input.																0.00 Hz	Yes	Q	Q	Q	Q	282H	4-5 6-10														
	Reference 3																																						
d1-04	Frequency reference 4	Sets the frequency reference when multi-step speed commands 1 and 2 are ON for multi-function inputs.																							0.00 Hz	Yes	Q	Q	Q	Q	283H	4-5 6-10							
	Reference 4																																						
d1-05	Frequency reference 5	Sets the frequency when multi-step speed command 3 is ON for a multi-function input.																														0.00 Hz	Yes	A	A	A	A	284H	6-10
	Reference 5																																						
d1-06	Frequency reference 6	Sets the frequency reference when multi-step speed commands 1 and 3 are ON for multi-function inputs.																																					0.00 Hz
	Reference 6																																						
d1-07	Frequency reference 7	Sets the frequency reference when multi-step speed commands 2 and 3 are ON for multi-function inputs.	0.00 Hz	Yes	A	A	A	A	286H	6-10																													
	Reference 7																																						
d1-08	Frequency reference 8	Sets the frequency reference when multi-step speed commands 1, 2, and 3 are ON for multi-function inputs.								0.00 Hz	Yes	A	A	A	A	287H	6-10																						
	Reference 8																																						
d1-09	Frequency reference 9	Sets the frequency reference when multi-step speed command 4 is ON for a multi-function input.															0.00 Hz	Yes	A	A	A	A	288H	6-10															
	Reference 9																																						
d1-10	Frequency reference 10	Sets the frequency reference when multi-step speed commands 1 and 4 are ON for multi-function inputs.																						0.00 Hz	Yes	A	A	A	A	28BH	6-10								
	Reference 10																																						
d1-11	Frequency reference 11	Sets the frequency reference when multi-step speed commands 2 and 4 are ON for a multi-function inputs.																													0.00 Hz	Yes	A	A	A	A	28CH	6-10	
	Reference 11																																						

Parameter Number	Name	Description	Setting Range	Factory Setting	Change during Operation	Control Methods				MEMO-BUS Register	Page																		
	Display					V/f	V/f with PG	Open Loop Vector	Closed Loop Vector																				
d1-12	Frequency reference 12	Sets the frequency reference when multi-step speed commands 1, 2, and 4 are ON for multi-function inputs.	0 to 50.00 *1*2	0.00 Hz	Yes	A	A	A	A	28DH	6-10																		
	Reference 12																												
d1-13	Frequency reference 13	Sets the frequency reference when multi-step speed commands 3 and 4 are ON for multi-function inputs.										0.00 Hz	Yes	A	A	A	A	A	28EH	6-10									
	Reference 13																												
d1-14	Frequency reference 14	Sets the frequency reference when multi-step speed commands 1, 3, and 4 are ON for multi-function inputs.																			0.00 Hz	Yes	A	A	A	A	A	28FH	6-10
	Reference 14																												
d1-15	Frequency reference 15	Sets the frequency reference when multi-step speed commands 2, 3, and 4 are ON for multi-function inputs.	0.00 Hz	Yes	A	A	A	A	A	290H	6-10																		
	Reference 15																												
d1-16	Frequency reference 16	Sets the frequency reference when multi-step speed commands 1, 2, 3, and 4 are ON for multi-function inputs.										0.00 Hz	Yes	A	A	A	A	A	291H	6-10									
	Reference 16																												
d1-17	Jog frequency reference	Sets the frequency reference when the jog frequency reference selection, FJOG command, or RJOG command is ON.																			6.00 Hz	Yes	Q	Q	Q	Q	Q	292H	4-5 6-10 6-72
	Jog Reference																												

* 1. The unit is set in o1-03 (frequency units of reference setting and monitor, default: 0.01 Hz). If the display unit is changed, the setting range values also change

* 2. The maximum setting value depends on the setting of the maximum output frequency (E1-04).

■ Reference Limits: d2

Parameter Number	Name	Description	Setting Range	Factory Setting	Change during Operation	Control Methods				MEMO-BUS Register	Page
	Display					V/f	V/f with PG	Open Loop Vector	Closed Loop Vector		
d2-01	Frequency reference upper limit	Sets the frequency reference upper limit as a percentage of the max. output frequency.	0.0 to 110.0	100.0%	No	A	A	A	A	289H	6-30 6-67
	Ref Upper Limit										
d2-02	Frequency reference lower limit	Sets the frequency reference lower limit as a percentage of the maximum output frequency.	0.0 to 110.0	0.0%	No	A	A	A	A	28AH	6-30 6-67
	Ref Lower Limit										
d2-03	Master speed reference lower limit	Sets the master speed reference lower limit as a percentage of the max. output frequency.	0.0 to 110.0	0.0%	No	A	A	A	A	293H	6-30 6-67
	Ref1 Lower Limit										

Jump Frequencies: d3

Parameter Number	Name	Description	Setting Range	Factory Setting	Change during Operation	Control Methods				MEMO-BUS Register	Page
	Display					V/f	V/f with PG	Open Loop Vector	Closed Loop Vector		
d3-01	Jump frequency 1	Set the center values of the jump frequencies in Hz. This function is disabled when the jump frequency is set to 0 Hz. Always ensure that the following applies: d3-01 ≥ d3-02 ≥ d3-03 Operation in the jump frequency range is prohibited but during acceleration and deceleration, the speed changes smoothly without jumping	0.0 to 150.0 *	0.0 Hz	No	A	A	A	A	294H	6-28
	Jump Freq 1										
d3-02	Jump frequency 2										
Jump Freq 2											
d3-03	Jump frequency 3	Sets the jump frequency bandwidth in Hz. The jump frequency range will be the jump frequency ± d3-04.	0.0 to 20.0	1.0 Hz	No	A	A	A	A	297H	6-28
	Jump Freq 3										
d3-04	Jump frequency width										
	Jump Bandwidth										

* The given setting range is valid if Heavy Duty is selected (C6-01=0, default setting). If Normal Duty 1 or 2 is selected (C6-01=1 or 2) the setting range will be 0.0 to 400.0 Hz

Reference Frequency Hold: d4

Parameter Number	Name	Description	Setting Range	Factory Setting	Change during Operation	Control Methods				MEMO-BUS Register	Page
	Display					V/f	V/f with PG	Open Loop Vector	Closed Loop Vector		
d4-01	Frequency reference hold function selection	Sets whether the frequency reference value on hold or power loss will be recorded or not. 0: Disabled (when operation is stopped or the power is turned on again the frequency reference is set to 0.) 1: Enabled (when operation is stopped or the power is turned on again the inverter starts at the previous hold frequency.) This function is available when the multi-function inputs "Accel/Decel Ramp Hold" or "Up/Down" commands are set.	0 or 1	0	No	A	A	A	A	298H	6-66
	MOP Ref Memory										
d4-02	+ – Speed limits	Sets the frequency to be add to or subtracted from the analog frequency reference as a percentage of the max. output frequency. Enabled when the increase (+) speed command or decrease (–) speed command is set for a multi-function input.	0 to 100	10%	No	A	A	A	A	299H	6-66
	Trim Control Lvl										

■ Torque Control: d5

Parameter Number	Name	Description	Setting Range	Factory Setting	Change during Operation	Control Methods				MEMO-BUS Register	Page
	Display					V/f	V/f with PG	Open Loop Vector	Closed Loop Vector		
d5-01	Torque control selection	<p>0: Speed control (C5-01 to C5-07)</p> <p>1: Torque control</p> <p>This function is available in Closed Loop Vector control mode only. To use the function for switching between speed and torque control, set d5-01 to 0 and set the multi-function input to “speed/torque control change.”</p>	0 or 1	0	No	No	No	No	A	29AH	6-118
	Torq Control Sel										
d5-02	Torque reference delay time	<p>Sets the torque reference delay time.</p> <p>It can be used to prevent oscillations caused by signal noise or to increase or decrease the responsiveness.</p> <p>When oscillation occurs during torque control, increase the set value.</p>	0 to 1000	0 ms	No	No	No	No	A	29BH	6-118
	Torq Ref Filter										
d5-03	Speed limit selection	<p>Sets the speed limit reference source for the torque control mode.</p> <p>1: The analog input limit from a frequency reference</p> <p>2: Limited by d5-04 parameter setting values.</p>	1 or 2	1	No	No	No	No	A	29CH	6-118
	Speed Limit Sel										
d5-04	Speed limit	<p>Sets the speed limit during torque control as a percentage of the maximum output frequency.</p> <p>This function is enabled when d5-03 is set to 2. Directions are as follows.</p> <p>+: run command direction</p> <p>-: run command opposite direction</p>	-120 to +120	0%	No	No	No	No	A	29DH	6-118
	Speed Lmt Value										
d5-05	Speed limit bias	<p>Sets the speed limit bias as a percentage of the maximum output frequency.</p> <p>The bias is applied to the specified speed limit. It can be used to adjust the margin for the speed limit.</p>	0 to 120	10%	No	No	No	No	A	29EH	6-118
	Speed Lmt Bias										
d5-06	Speed/torque control switching timer	<p>Sets the delay time from inputting a “speed/torque control change” (Digital input from On to OFF or OFF to ON) until the control is actually changed.</p> <p>This function is enabled when the multi-function input “speed/torque control change” is set. The analog inputs values are hold from the point, when the “speed/torque control change” is activated.</p>	0 to 1000	0 ms	No	No	No	No	A	29FH	6-118
	Ref Hold Time										

■Field Weakening: d6

Parameter Number	Name	Description	Setting Range	Factory Setting	Change during Operation	Control Methods				MEMO-BUS Register	Page
	Display					V/f	V/f with PG	Open Loop Vector	Closed Loop Vector		
d6-01	Field weakening level	Sets the inverter output voltage when the field weakening command is input at a digital input.	0 to 100	80%	No	A	A	No	No	2A0H	6-107
	Field-Weak Lvl	Sets the voltage level as a percentage taking the voltage set by the V/f pattern as 100%.									
d6-02	Field weakening frequency limit	Sets the lower limit of the frequency range where field control is valid.	0.0 to 150.0 *	0.0 Hz	No	A	A	No	No	2A1H	6-107
	Field-Weak Freq	The field weakening command is accepted only at frequencies above this setting and only when the speed is in agreement with the current speed reference.									
d6-03	Field forcing function selection	Enables or disables field forcing function. 0: Disabled 1: Enabled	0 or 1	0	No	No	No	No	A	2A2H	6-108
	Field Force Sel										
d6-06	Field forcing function Limit	Sets the upper limit for the excitation current applied by the field forcing function. A setting of 100% is equal to the motor no-load current.	100 to 400	400%	No	No	No	A	A	2A5H	6-108
	FieldForce Limit	Field forcing is active during all types of operation except DC Injection.									

* The given setting range is valid if Heavy Duty is selected (C6-01=0, default setting). If Normal Duty 1 or 2 is selected (C6-01=1 or 2) the setting range will be 0.0 to 400.0 Hz

◆ Motor Parameters: E

■ V/f Pattern: E1

Parameter Number	Name Display	Description	Setting Range	Factory Setting	Change during Operation	Control Methods				MEMO-BUS Register	Page
						V/f	V/f with PG	Open Loop Vector	Closed Loop Vector		
E1-01	Input voltage setting	Sets the Inverter input voltage. This setting is used as a reference value for protection functions.	155 to 255 *1	200 V *1	No	Q	Q	Q	Q	300H	4-5 6-110
	Input Voltage										
E1-03	V/f pattern selection	0 to E: Select from the 15 preset patterns. F: Custom user-set pattern (Applicable for setting of E1-04 to E1-10.)	0 to F	F	No	Q	Q	No	No	302H	6-110
	V/f Selection										
E1-04	Max. output frequency (FMAX)		40.0 to 150.0 *2	50.0 Hz	No	Q	Q	Q	Q	303H	6-110
	Max Frequency										
E1-05	Max. output voltage (VMAX)		0.0 to 255.0 *1	200.0 V *1	No	Q	Q	Q	Q	304H	6-110
	Max Voltage										
E1-06	Base frequency (FA)	<p>Output Voltage (V)</p> <p>VMAX (E1-05) (VBASE) (E1-13)</p> <p>VB (E1-08)</p> <p>VMIN (E1-10)</p> <p>FMIN (E1-09) FB (E1-07) FA (E1-06) FMAX (E1-04)</p> <p>Frequency (Hz)</p>	0.0 to 150.0 *2	50.0 Hz	No	Q	Q	Q	Q	305H	6-110
	Base Frequency										
E1-07	Mid. output frequency (FB)	<p>To set V/f characteristics in a straight line, set the same values for E1-07 and E1-09. In this case, the setting for E1-08 will be disregarded. Always ensure that the four frequencies are set in the following manner: E1-04 (FMAX) ≥ E1-06 (FA) > E1-07 (FB) ≥ E1-09 (FMIN)</p>	0.0 to 150.0 *2	3.0 Hz *3	No	A	A	A	No	306H	6-110
	Mid Frequency A										
E1-08	Mid. output frequency voltage (VB)		0.0 to 255 *1	13.2 V *1 *3	No	A	A	A	No	307H	4-14 6-110
	Mid Voltage A										
E1-09	Min. output frequency (FMIN)		0.0 to 150.0 *2	0.5 Hz *3	No	Q	Q	Q	A	308H	6-110
	Min Frequency										
E1-10	Min. output frequency voltage (VMIN)		0.0 to 255.0 *1	2.4 V *1 *3	No	A	A	A	No	309H	4-14 6-110
	Min Voltage										

Parameter Number	Name	Description	Setting Range	Factory Setting	Change during Operation	Control Methods				MEMO-BUS Register	Page
	Display					V/f	V/f with PG	Open Loop Vector	Closed Loop Vector		
E1-11	Mid. output frequency 2	Set only to fine-adjust V/f for the output range. Normally, this setting is not required. E1-11 must be set higher than E1-04.	0.0 to 150.0 *2	0.0 Hz *4	No	A	A	A	A	30AH	6-110
	Mid Frequency B										
E1-12	Mid. output frequency voltage 2		0.0 to 255.0 *1	0.0 V *4	No	A	A	A	A	30BH	6-110
	Mid Voltage B										
E1-13	Base voltage (VBASE)	Sets the output voltage of the base frequency (E1-06).	0.0 to 255.0 *1	0.0 V *5	No	A	A	Q	Q	30CH	6-110
	Base Voltage										

- * 1. These are values for a 200 V Class Inverter. Values for a 400 V Class Inverter are double.
- * 2. The given setting range is valid if Heavy Duty is selected (C6-01=0, default setting). If Normal Duty 1 or 2 is selected (C6-01=1 or 2) the setting range will be 0.0 to 400.0 Hz
- * 3. The factory setting will change when the control method is changed. (The Open Loop Vector Control factory settings are given.)
- * 4. E1-11 and E1-12 are disregarded when set to 0.0.
- * 5. E1-13 is set to the same value as E1-05 by autotuning.

■ Motor Setup: E2

Parameter Number	Name	Description	Setting Range	Factory Setting	Change during Operation	Control Methods				MEMO-BUS Register	Page
	Display					V/f	V/f with PG	Open Loop Vector	Closed Loop Vector		
E2-01	Motor rated current	Sets the motor rated current. This set value will become the reference value for motor protection and torque limits. This parameter is an input data for autotuning.	0.32 to 6.40 *1	1.90 A *2	No	Q	Q	Q	Q	30EH	6-48 6-108
	Motor Rated FLA										
E2-02	Motor rated slip	Sets the motor rated slip. This set value will become the reference value for the slip compensation. This parameter is automatically set during autotuning.	0.00 to 20.00	2.90 Hz *2	No	A	A	A	A	30FH	6-108
	Motor Rated Slip										
E2-03	Motor no-load current	Sets the motor no-load current. This parameter is automatically set during autotuning.	0.00 to 1.89 *3	1.20 A *2	No	A	A	A	A	310H	6-108
	No-Load Current										
E2-04	Number of motor poles	Sets the number of motor poles. This value is an input data for autotuning.	2 to 48	4 poles	No	No	Q	Q	Q	311H	6-108
	Number of Poles										
E2-05	Motor line-to-line resistance	Sets the motor phase-to-phase resistance. This parameter is automatically set during autotuning.	0.000 to 65.000	9.842 Ω *2	No	A	A	A	A	312H	6-108
	Term Resistance										
E2-06	Motor leak inductance	Sets the voltage drop due to motor leakage inductance as a percentage of the motor rated voltage. This parameter is automatically set during autotuning.	0.0 to 40.0	18.2% *2	No	No	No	A	A	313H	6-108
	Leak Inductance										

Parameter Number	Name	Description	Setting Range	Factory Setting	Change during Operation	Control Methods				MEMO-BUS Register	Page
	Display					V/f	V/f with PG	Open Loop Vector	Closed Loop Vector		
E2-07	Motor iron saturation coefficient 1	Sets the motor iron saturation coefficient at 50% of magnetic flux. This parameter is automatically set during rotating autotuning.	0.00 to 0.50	0.50	No	No	No	A	A	314H	6-108
	Saturation Comp1										
E2-08	Motor iron saturation coefficient 2	Sets the motor iron saturation coefficient at 75% of magnetic flux. This parameter is automatically set during rotating autotuning.	0.50 to 0.75	0.75	No	No	No	A	A	315H	6-108
	Saturation Comp2										
E2-09	Motor mechanical losses	Sets the motor mechanical losses as a percentage of motor rated output. Usually changing this setting is not necessary.	0.0 to 10.0	0.0%	No	No	No	No	A	316H	6-108
	Mechanical loss	Adjust the value under the following the torque loss is large due e.g. to heavy friction in the machine. The set mechanical loss will be compensated.									
E2-10	Motor iron loss for torque compensation	Sets motor iron losses.	0 to 65535	14 W *2	No	A	A	No	No	317H	6-108
	Tcomp Iron Loss										
E2-11	Motor rated output power	Sets the rated output power of the motor. This parameter is an input data for autotuning.	0.00 to 650.00	0.40 *2	No	Q	Q	Q	Q	318H	6-108
	Mtr Rated Power										

* 1. The setting range is 10% to 200% of the Inverter's rated output current. The value for a 200 V class inverter of 0.4 kW is given.

* 2. The factory setting depends upon the Inverter capacity. The value for a 200 V class inverter of 0.4 kW is given.

* 3. The setting range depends on the inverter capacity. The value for a 200 V class inverter of 0.4 kW is given.

Motor 2 V/f Pattern: E3

Parameter Number	Name	Description	Setting Range	Factory Setting	Change during Operation	Control Methods				MEMO-BUS Register	Page	
	Display					V/f	V/f with PG	Open Loop Vector	Closed Loop Vector			
E3-01	Motor 2 control method selection	0: V/f control 1: V/f control with PG 2: Open Loop Vector control 3: Closed Loop Vector Control	0 to 3	0	No	A	A	A	A	319H	6-117	
	Control Method											
E3-02	Motor 2 max. output frequency (FMAX)	<p>To set V/f characteristics in a straight line, set the same values for E3-05 and E3-07. In this case, the setting for E3-06 will be disregarded. Always ensure that the four frequencies are set in the following manner: E3-02 (FMAX) ≥ E3-04 (FA) > E3-05 (FB) > E3-07 (FMIN)</p>	40.0 to 150.0 *1	50.0 Hz	No	A	A	A	A	31AH	6-117	
	Max Frequency											
E3-03	Motor 2 max. output voltage (VMAX)		0.0 to 255.0 *2	200.0 V *2	No	A	A	A	A	A	31BH	6-117
	Max Voltage											
E3-04	Motor 2 max. voltage frequency (FA)		0.0 to 150.0 *1	50.0 Hz	No	A	A	A	A	A	31CH	6-117
	Base Frequency											
E3-05	Motor 2 mid. output frequency 1 (FB)		0.0 to 150.0 *1	2.5 Hz *3	No	A	A	A	No	31DH	6-117	
	Mid Frequency											
E3-06	Motor 2 mid. output frequency voltage 1 (VB)	0.0 to 255.0 *2	15.0 V *2*3	No	A	A	A	No	31EH	6-117		
	Mid Voltage											
E3-07	Motor 2 min. output frequency (FMIN)	0.0 to 150.0 *1	1.2 Hz *3	No	A	A	A	A	31FH	6-117		
	Min Frequency											
E3-08	Motor 2 min. output frequency voltage (VMIN)	0.0 to 255.0 *2	9.0 V *2*3	No	A	A	A	No	320H	6-117		
	Min Voltage											

* 1. The given setting range is valid if Heavy Duty is selected (C6-01=0, default setting). If Normal Duty 1 or 2 is selected (C6-01=1 or 2) the setting range will be 0.0 to 400.0 Hz

* 2. These are values for a 200 V class Inverter. Values for a 400 V class Inverter are double.

* 3. The factory setting will change when the control method is changed. (V/f control factory settings are given.)

■ Motor 2 Setup: E4

Parameter Number	Name	Description	Setting Range	Factory Setting	Change during Operation	Control Methods				MEMO-BUS Register	Page
	Display					V/f	V/f with PG	Open Loop Vector	Closed Loop Vector		
E4-01	Motor 2 rated current	Sets the motor rated current. This set value will become a reference value for motor protection and torque limits. This parameter is an input data for autotuning.	0.32 to 6.40 *1	1.90 A *2	No	A	A	A	A	321H	6-48 6-117
	Motor Rated FLA										
E4-02	Motor 2 rated slip	Sets the motor rated slip. This set value will become a reference value for slip compensation. This parameter is automatically set during autotuning.	0.00 to 20.00	2.90 Hz *2	No	A	A	A	A	322H	6-117
	Motor Rated Slip										
E4-03	Motor 2 no-load current	Sets the motor no-load current. This parameter is automatically set during autotuning.	0.00 to 1.89 *3	1.20 A *2	No	A	A	A	A	323H	6-117
	No-Load Current										
E4-04	Motor 2 number of poles (number of poles)	Sets the number of motor poles. This value is an input data for autotuning.	2 to 48	4 poles	No	No	A	No	A	324H	6-117
	Number of Poles										
E4-05	Motor 2 line-to-line resistance	Sets the motor phase-to-phase resistance in Ω units. This parameter is automatically set during autotuning.	0.000 to 65.000	9.842 Ω *2	No	A	A	A	A	325H	6-117
	Mid Frequency										
E4-06	Motor 2 leak inductance	Sets the voltage drop due to motor leakage inductance as a percentage of the motor rated voltage. This parameter is automatically set during autotuning.	0.0 to 40.0	18.2% *2	No	No	No	A	A	326H	6-117
	Leak Inductance										
E4-07	Motor 2 rated capacity	Sets the rated output of the motor in units of 0.01 kW. This parameter is an input data for autotuning.	0.40 to 650.00	0.40 *2	No	A	A	A	A	327H	6-117
	Mtr Rated Power										

* 1. The setting range is 10% to 200% of the Inverter's rated output current. The values for a 200 V class Inverter of 0.4 kW is given.

* 2. The factory setting depends upon the Inverter capacity. The value for a 200 V class Inverter of 0.4 kW is given.

* 3. The setting range will depend upon the Inverter capacity. The value for a 200 V class Inverter of 0.4 kW is given.

◆ Option Parameters: F

■ PG Option Setup: F1

Parameter Number	Name	Description	Setting Range	Factory Setting	Change during Operation	Control Methods				MEMO-BUS Register	Page
	Display					V/f	V/f with PG	Open Loop Vector	Closed Loop Vector		
F1-01	PG constant	Sets the number of PG pulses per revolution	0 to 60000	1024	No	No	Q	Q	Q	380H	6-138
	PG Pulses/Rev										
F1-02	Operation selection at PG open circuit (PGO)	Sets the PG disconnection stopping method. 0: Ramp to stop (Deceleration to stop using the deceleration time 1, C1-02.) 1: Coast to stop 2: Fast stop (Emergency stop using the deceleration time in C1-09.) 3: Continue operation (To protect the motor or machinery, avoid to use this setting.)	0 to 3	1	No	No	A	No	A	381H	6-138
	PG Fdbk Loss Sel										
F1-03	Operation selection at overspeed (OS)	Sets the stopping method when an overspeed (OS) fault occurs. 0: Ramp to stop (Deceleration to stop using the deceleration time 1, C1-02.) 1: Coast to stop 2: Fast stop (Emergency stop using the deceleration time in C1-09.) 3: Continue operation (To protect the motor or machinery, avoid to use this setting.)	0 to 3	1	No	No	A	No	A	382H	6-138
	PG Over-speed Sel										
F1-04	Operation selection at deviation	Sets the stopping method when a speed deviation (DEV) fault occurs. 0: Ramp to stop (Deceleration to stop using the deceleration time 1, C1-02.) 1: Coast to stop 2: Fast stop (Emergency stop using the deceleration time in C1-09.) 3: Continue operation (DEV is displayed and operation continued.)	0 to 3	3	No	No	A	No	A	383H	6-138
	PG Deviation Sel										
F1-05	PG rotation	0: Phase A leads with forward run command. (Phase B leads with reverse run command, C.C.W.) 1: Phase B leads with forward run command. (Phase A leads with reverse run command, C.W.)	0 or 1	0	No	No	A	A	A	384H	6-138
	PG Rotation Sel										

Parameter Number	Name	Description	Setting Range	Factory Setting	Change during Operation	Control Methods				MEMO-BUS Register	Page
	Display					V/f	V/f with PG	Open Loop Vector	Closed Loop Vector		
F1-06	PG division rate (PG pulse monitor)	Sets the division ratio for the PG speed control card pulse output. Division ratio = (1 + n) / m (n=0 or 1 m=1 to 32) The first digit of the value of F1-06 stands for n, the second and the third stands for m. This parameter is effective only when a PG-B2 is used. The possible division ratio settings are: $1/32 \leq F1-06 \leq 1$.	1 to 132	1	No	No	A	A	A	385H	6-138
	PG Output Ratio										
F1-07	Integral value during accel/decel enable/disable	Enables or disables integral control during acceleration/deceleration. 0: Disabled (The integral function isn't used while acceleration or deceleration; it is used at constant speeds only.) 1: Enabled (The integral function is always used.)	0 or 1	0	No	No	A	No	No	386H	6-138
	PG Ramp PI/I Sel										
F1-08	Overspeed detection level	Sets the overspeed detection method. Motor speeds that continue to exceed the value set in F1-08 (set as a percentage of the maximum output frequency) for the time set in F1-09 are detected as overspeed faults.	0 to 120	115%	No	No	A	No	A	387H	6-138
	PG Overspd Level										
F1-09	Overspeed detection delay time		0.0 to 2.0	0.0 s	No	No	A	No	A	388H	6-138
	PG Overspd Time										
F1-10	Excessive speed deviation detection level	Sets the speed deviation detection method. Any speed deviation above the F1-10 set level (set as a percentage of the maximum output frequency) that continues for the time set in F1-11 is detected as a speed deviation. The speed deviation is the difference between actual motor speed and the speed reference command.	0 to 50	10%	No	No	A	No	A	389H	6-138
	PG Deviate Level										
F1-11	Excessive speed deviation detection delay time		0.0 to 10.0	0.5 s	No	No	A	No	A	38AH	6-138
	PG Deviate Time										
F1-12	Number of PG gear teeth 1	Sets the number of teeth on the gears if there are gears between the PG and the motor. $\frac{\text{PG Input Pulses} \times 60}{F1-01} \times \frac{F1-13}{F1-12}$	0 to 1000	0	No	No	A	No	No	38BH	6-138
	PG # Gear Teeth 1										
F1-13	Number of PG gear teeth 2	A gear ratio of 1 will be used if one of these parameters is set to 0.		0	No	No	A	No	No	38CH	6-138
	PG # Gear Teeth 1										

Parameter Number	Name	Description	Setting Range	Factory Setting	Change during Operation	Control Methods				MEMO-BUS Register	Page
	Display					V/f	V/f with PG	Open Loop Vector	Closed Loop Vector		
F1-14	PG open-circuit detection delay time	Used to set the PG disconnection detection time. PGO will be detected if the detection time exceeds the set time.	0.0 to 10.0	2.0 s	No	No	A	No	A	38DH	6-138
	PGO Detect Time										

■ Analog Reference Card: F2

Parameter Number	Name	Description	Setting Range	Factory Setting	Change during Operation	Control Methods				MEMO-BUS Register	Page
	Display					V/f	V/f with PG	Open Loop	Closed Loop Vector		
F2-01	Bi-polar or uni-polar input selection	<p>If an AI-14B analog reference card is used this parameter sets the functions for the input channels 1 to 3.</p> <p>0: 2-channel individual, the AI-14B input channels replace the analog input terminals A1 to A2 of the inverter (Channel 1: terminal A1, Channel 2: terminal A2). Channel 3 is not used.</p> <p>1: 3-channel addition (Addition values are the frequency reference)</p> <p>When b1-01 is set to 1 and F2-01 is set to 0, the digital input function "Option/Inverter selection" can't be used.</p>	0 or 1	0	No	A	A	A	A	38FH	6-141
	AI-14 Input Sel										

■ Digital Reference Card: F3

Parameter Number	Name	Description	Setting Range	Factory Setting	Change during Operation	Control Methods				MEMO BUS Register	Page
	Display					V/f	V/f with PG	Open Loop Vector 1	Closed Loop Vector		
F3-01	Digital input option	Sets the Digital Reference Card input method. 0: BCD 1% unit 1: BCD 0.1% unit 2: BCD 0.01% unit 3: BCD 1 Hz unit 4: BCD 0.1 Hz unit 5: BCD 0.01 Hz unit 6: BCD special setting (5-digit input) 7: Binary input 6 is effective only, when the DI-16H2 is used. When o1-03 is set to 2 or higher, the input will be BCD, and the units will change to the o1-03 setting.	0 to 7	0	No	A	A	A	A	390H	6-141
	DI Input										

■ Analog Output Option Card Setup: F4

Parameter Number	Name	Description	Setting Range	Factory Setting	Change during Operation	Control Methods				MEM OBUS Register	Page
						V/f	V/f with PG	Open Loop Vector	Closed Loop Vector		
F4-01	Channel 1 Monitor Selection	This function is enabled when the analog monitor card is used.	1 to 38	2	No	A	A	A	A	391H	
F4-02	Channel 1 Gain	Monitor selection: Sets the number of the monitor item to be output. (Numerical portion □□ of U1-□□)	0.0 to 100.0	100.0%	Yes	A	A	A	A	392H	
F4-03	Channel 2 Monitor Selection	4, 10, 11, 12, 13, 14, 25, 28, 35, 39 and 40 cannot be set.	1 to 38	3	No	A	A	A	A	393H	
F4-04	Channel 2 Gain	Gain: Sets the percentage of the monitor item, which is equal to 10V output.	0.0 to 100.0	50.0%	Yes	A	A	A	A	394H	
F4-05	CH1 Output Bias	Bias: Sets the percentage of the monitor item, which is equal to 0V output.	-110.0 to 110.0	0.0%	Yes	A	A	A	A	395H	
F4-06	CH2 Output Bias		-110.0 to 110.0	0.0%	Yes	A	A	A	A	396H	
F4-07	Analog Output Signal Level CH1	Selects the analog output signal level for channel 1 (effective for the AO-12 option card only).	0, 1	0	No	A	A	A	A	397H	
F4-08	Analog Output Signal Level CH2	0: 0 to 10V 1: -10 to +10 Using an AO-08 option card the possible outputs signal is 0 to +10V only. The setting of F4-07 and F4-08 has no effect.	0, 1	0	No	A	A	A	A	398H	

■ Digital Output Option Card Setup: F5

Parameter Number	Name	Description	Setting Range	Factory Setting	Change during Operation	Control Methods				MEMO BUS Register	Page
						V/f	V/f with PG	Open Loop Vector	Closed Loop Vector		
F5-01	Channel 1 Output Selection	Selects the desired multi-function output for channel 1. This function is enabled when a digital output card (DO-02 or DO-08) is used.	00 to 38	0	No	A	A	A	A	399H	
F5-02	Channel 2 Output Selection	Selects the desired multi-function output for channel 2. This function is enabled when a digital output card (DO-02 or DO-08) is used.	00 to 38	1	No	A	A	A	A	39AH	
F5-03	Channel 3 Output Selection	Selects the desired multi-function output for channel 3. This function is enabled when a digital output card (DO-02 or DO-08) is used.	0 to 38	2	No	A	A	A	A	39BH	
F5-04	Channel 4 Output Selection	Selects the desired multi-function output for channel 4. This function is enabled when a digital output card (DO-02 or DO-08) is used.	0 to 38	4	No	A	A	A	A	39CH	
F5-05	Channel 5 Output Selection	Selects the desired multi-function output for channel 5. This function is enabled when a digital output card (DO-02 or DO-08) is used.	0 to 38	6	No	A	A	A	A	39DH	
F5-06	Channel 6 Output Selection	Selects the desired multi-function output for channel 6. This function is enabled when a digital output card (DO-02 or DO-08) is used.	0 to 38	37	No	A	A	A	A	39EH	
F5-07	Channel 7 Output Selection	Selects the desired multi-function output for channel 7. This function is enabled when a digital output card (DO-02 or DO-08) is used.	0 to 38	0F	No	A	A	A	A	39FH	
F5-08	Channel 8 Output Selection	Selects the desired multi-function output for channel 8. This function is enabled when a digital output card (DO-02 or DO-08) is used.	0 to 38	0F	No	A	A	A	A	3A0H	
F5-09	DO-08 Output Mode Selection	Sets the output mode. This function is enabled when the digital output card (DO-08) is used. 0: 8-Channel Individual Outputs 1: Binary Code Output 2: Outputs according to F5-01 to 08 settings.	0 to 2	0	No	A	A	A	A	3A1H	

Serial Communications Settings: F6

Parameter Number	Name	Description	Setting Range	Factory Setting	Change during Operation	Control Methods				MEMO-BUS Register	Page
	Display					V/f	V/f with PG	Open Loop Vector	Closed Loop Vector		
F6-01	Operation selection after communications error	Sets the stopping method for communications errors. 0: Deceleration to stop using the deceleration time in C1-02 1: Coast to stop 2: Emergency stop using the deceleration time in C1-09 3: Continue operation	0 to 3	1	No	A	A	A	A	3A2H	-
	Comm Bus Flt Sel										
F6-02	Input level of external error from Communications Option Card	0: Always detect 1: Detect during operation	0 or 1	0	No	A	A	A	A	3A3H	-
	EF0 Fault Detection										
F6-03	Stopping method for external error from Communications Option Card	0: Deceleration to stop using the deceleration time in C1-02 1: Coast to stop 2: Emergency stop using the deceleration time in C1-09 3: Continue operation	0 to 3	1	No	A	A	A	A	3A4H	-
	EF0 Fault Action										
F6-04	Trace sampling from Communications Option Card	-	0 to 60000	0	No	A	A	A	A	3A5H	-
	Trace Sample Tim										
F6-05	Current monitor unit selection	Sets the unit of current monitor 0: Ampere 1: 100%/8192	0 or 1	0	No	A	A	A	A	3A6H	-
	Current Unit Sel										
F6-06	Torque reference/torque limit selection from communications option card	0: Torque reference/torque limit by communications option disabled. 1: Torque reference/torque limit by communications option enabled.	0 or 1	0	No	No	No	No	A	3A7H	-
	Torque Ref/Lmt Sel										

◆ Terminal Function Parameters: H

■ Multi-function Digital Inputs: H1

Parameter Number	Name	Description	Setting Range	Factory Setting	Change during Operation	Control Methods				MEMO-BUS Register	Page
	Display					V/f	V/f with PG	Open Loop Vector	Closed Loop Vector		
H1-01	Terminal S3 function selection	Multi-function input 1	0 to 78	24	No	A	A	A	A	400H	-
	Terminal S3 Sel										
H1-02	Terminal S4 function selection	Multi-function input 2	0 to 78	14	No	A	A	A	A	401H	-
	Terminal S3 Sel										
H1-03	Terminal S5 function selection	Multi-function input 3	0 to 78	3 (0)*	No	A	A	A	A	402H	-
	Terminal S3 Sel										
H1-04	Terminal S6 function selection	Multi-function input 4	0 to 78	4 (3)*	No	A	A	A	A	403H	-
	Terminal S3 Sel										
H1-05	Terminal S7 function selection	Multi-function input 5	0 to 78	6 (4)*	No	A	A	A	A	404H	-
	Terminal S3 Sel										

* The values in parentheses indicate initial values when initialized in 3-wire sequence.

Multi-function Digital Input Functions

Setting Value	Function	Control Methods				Page
		V/f	V/f with PG	Open Loop Vector	Closed Loop Vector	
0	3-wire sequence (Forward/Reverse Run command)	Yes	Yes	Yes	Yes	6-13
1	Local/Remote selection (ON: Operator, OFF: Parameter b1-01/b1-02 setting)	Yes	Yes	Yes	Yes	6-64
2	Operation Source Option Card/Inverter (OFF: Option Card, ON: b1-01/b1-02)	Yes	Yes	Yes	Yes	6-72
3	Multi-step speed reference 1 If H3-09 is set to 2, this function is combined with the master/auxiliary speed switch.	Yes	Yes	Yes	Yes	6-10
4	Multi-step speed reference 2	Yes	Yes	Yes	Yes	6-10
5	Multi-step speed reference 3	Yes	Yes	Yes	Yes	6-10
6	Jog frequency command (higher priority than multi-step speed reference)	Yes	Yes	Yes	Yes	6-10
7	Accel/decel time selection 1	Yes	Yes	Yes	Yes	6-20
8	External baseblock NO (NO contact: Baseblock at ON)	Yes	Yes	Yes	Yes	6-64
9	External baseblock NC (NC contact: Baseblock at OFF)	Yes	Yes	Yes	Yes	6-64
A	Acceleration/deceleration ramp hold (ON: Acceleration/deceleration stopped, frequency is hold)	Yes	Yes	Yes	Yes	6-66
B	OH2 alarm signal input (ON: OH2 will be displayed)	Yes	Yes	Yes	Yes	6-65
C	Multi-function analog input A2 disable/enable (ON: Enable)	Yes	Yes	Yes	Yes	6-65

Setting Value	Function	Control Methods				Page
		V/f	V/f with PG	Open Loop Vector	Closed Loop Vector	
D	V/f control with/without PG (ON: Speed feedback control disabled,) (normal V/f control)	No	Yes	No	No	6-37
E	Speed control integral disable (ON: Integral control disabled)	No	Yes	No	Yes	6-37
F	Not used (Set when a terminal is not used)	-	-	-	-	-
10	Up command (Always set with the Down command)	Yes	Yes	Yes	Yes	6-67
11	Down command (Always set with the Up command)	Yes	Yes	Yes	Yes	6-67
12	FJOG command (ON: Forward run at jog frequency d1-17)	Yes	Yes	Yes	Yes	6-72
13	RJOG command (ON: Reverse run at jog frequency d1-17)	Yes	Yes	Yes	Yes	6-72
14	Fault reset (Reset when turned ON)	Yes	Yes	Yes	Yes	7-2
15	Emergency stop. (NO: Deceleration to stop in deceleration time set in C1-09 when ON.)	Yes	Yes	Yes	Yes	6-18
16	Motor switch command (Motor 2 selection)	Yes	Yes	Yes	Yes	6-116
17	Emergency stop (NC: Deceleration to stop in deceleration time set in C1-09 when OFF)	Yes	Yes	Yes	Yes	6-18
18	Timer function input (Functions are set in b4-01 and b4-02 and the timer function outputs are set in H2-□□.)	Yes	Yes	Yes	Yes	6-95
19	PID control disable (ON: PID control disabled)	Yes	Yes	Yes	Yes	6-96
1A	Accel/Decel time 2	Yes	Yes	Yes	Yes	6-20
1B	Parameters write enable (ON: All parameters can be written-in. OFF: All parameters are write protected.)	Yes	Yes	Yes	Yes	6-136
1C	Trim control increase (ON: d4-02 frequency is added to analog frequency reference.)	Yes	Yes	Yes	Yes	6-70
1D	Trim control decrease (ON: d4-02 frequency is subtracted from analog frequency reference.)	Yes	Yes	Yes	Yes	6-70
1E	Analog frequency reference sample/hold	Yes	Yes	Yes	Yes	6-71
20 to 2F	External fault Input mode: NO contact/NC contact, Detection mode: Normal/during operation	Yes	Yes	Yes	Yes	6-66
30	PID control integral reset (reset when reset command is input or when stopped during PID control)	Yes	Yes	Yes	Yes	6-96
31	PID control integral hold (ON: Hold)	Yes	Yes	Yes	Yes	6-96
32	Multi-step speed command 4	Yes	Yes	Yes	Yes	6-10
34	PID soft starter disable	Yes	Yes	Yes	Yes	6-96
35	PID input characteristics switch	Yes	Yes	Yes	Yes	6-96
60	DC injection braking command (ON: Performs DC injection braking)	Yes	Yes	Yes	Yes	6-17
61	External search command 1 (ON: Speed search from maximum output frequency)	Yes	No	Yes	No	6-53
62	External search command 2 (ON: Speed search from set frequency)	Yes	No	Yes	No	6-53
63	Field weakening command (ON: Field weakening control set for d6-01 and d6-02)	Yes	Yes	No	No	6-107
64	External speed search command 3	Yes	Yes	Yes	Yes	6-53
65	Kinetic energy buffering (deceleration at momentary power loss) command (NC contact)	Yes	Yes	Yes	Yes	6-127
66	Kinetic energy buffering (deceleration at momentary power loss) command (NO contact)	Yes	Yes	Yes	Yes	6-127
67	Communications test mode	Yes	Yes	Yes	Yes	6-94
68	High-slip braking (HSB)	Yes	Yes	No	No	6-128
69	Jog Frequency 2	Yes	Yes	Yes	Yes	6-11
6A	Drive enable (NC, ON: Drive enabled, OFF: Drive disabled)	Yes	Yes	Yes	Yes	6-66
71	Speed/torque control change (ON: Torque control)	No	No	No	Yes	6-122
72	Zero-servo command (ON: Zero-servo)	No	No	No	Yes	6-125
77	Speed control (ASR) gain switching (ON: C5-03)	No	No	No	Yes	6-37
78	Polarity reversing command for external torque reference	No	No	No	Yes	6-119

■ Multi-function Contact Outputs: H2

Parameter Number	Name	Description	Setting Range	Factory Setting	Change during Operation	Control Methods				MEMO-BUS Register	Page
	Display					V/f	V/f with PG	Open Loop Vector	Closed Loop Vector		
H2-01	Terminal M1-M2 function selection	Multi-function contact output 1	0 to 38	0	No	A	A	A	A	40BH	-
	Term M1-M2 Sel										
H2-02	Terminal M3-M4 function selection	Multi-function contact output 2	0 to 38	1	No	A	A	A	A	40CH	-
	Term M3-M4 Sel										
H2-03	Terminal M5-M6 function selection	Multi-function contact output 3	0 to 38	2	No	A	A	A	A	40DH	-
	Term M5-M6 Sel										

Multi-function Contact Output Functions

Setting Value	Function	Control Methods				Page
		V/f	V/f with PG	Open loop Vector	Closed Loop Vector	
0	During run (ON: run command is ON or voltage is being output)	Yes	Yes	Yes	Yes	6-74
1	Zero-speed	Yes	Yes	Yes	Yes	6-74
2	$f_{ref} = f_{out}$ agree 1 (detection width L4-02 is used.)	Yes	Yes	Yes	Yes	6-32
3	$f_{ref} = f_{set}$ agree 1 (ON: Output frequency = \pm L4-01, with detection width L4-02 used and during frequency agree)	Yes	Yes	Yes	Yes	6-32
4	Frequency detection 1 (ON: $+L4-01 \geq$ output frequency $\geq -L4-01$, with detection width L4-02 used)	Yes	Yes	Yes	Yes	6-32
5	Frequency detection 2 (ON: Output frequency $\geq +L4-01$ or output frequency $\leq -L4-01$, with detection width L4-02 used)	Yes	Yes	Yes	Yes	6-32
6	Inverter operation ready READY: After initialization or no faults	Yes	Yes	Yes	Yes	6-75
7	During DC bus undervoltage (UV) detection	Yes	Yes	Yes	Yes	6-75
8	During baseblock (NO contact, ON: during baseblock)	Yes	Yes	Yes	Yes	6-75
9	Frequency reference source selection (ON: Frequency reference from Operator)	Yes	Yes	Yes	Yes	6-75
A	Run command source selection status (ON: Run command from Operator)	Yes	Yes	Yes	Yes	6-75
B	Overtorque/undertorque detection 1 NO (NO contact, ON: Overtorque/undertorque detection)	Yes	Yes	Yes	Yes	6-46
C	Loss of frequency reference (Effective when 1 is set for L4-05)	Yes	Yes	Yes	Yes	6-57
D	Braking resistor fault (ON: Resistor overheat or braking transistor fault)	Yes	Yes	Yes	Yes	6-59
E	Fault (ON: Digital Operator communications error or fault other than CPF00 and CPF01 has occurred.)	Yes	Yes	Yes	Yes	6-75
F	Not used. (Set when the terminal is not used.)	Yes	Yes	Yes	Yes	-
10	Minor fault (ON: Alarm displayed)	Yes	Yes	Yes	Yes	6-75
11	Fault reset command active	Yes	Yes	Yes	Yes	6-75
12	Timer function output	Yes	Yes	Yes	Yes	6-95
13	$f_{ref} = f_{set}$ agree 2 (detection width L4-04 is used)	Yes	Yes	Yes	Yes	6-32
14	$f_{ref} = f_{set}$ agree 2 (ON: Output frequency = L4-03, with detection width L4-04 is used, and during frequency agree)	Yes	Yes	Yes	Yes	6-32

Setting Value	Function	Control Methods				Page
		V/f	V/f with PG	Open loop Vector	Closed Loop Vector	
15	Frequency detection 3 (ON: Output frequency \leq -L4-03, detection width L4-04 is used)	Yes	Yes	Yes	Yes	6-32
16	Frequency detection 4 (ON: Output frequency \geq -L4-03, detection width L4-04 is used)	Yes	Yes	Yes	Yes	6-32
17	Overtorque/undertorque detection 1 NC (NC Contact, OFF: Torque detection)	Yes	Yes	Yes	Yes	6-46
18	Overtorque/undertorque detection 2 NO (NO Contact, ON: Torque detection)	Yes	Yes	Yes	Yes	6-46
19	Overtorque/undertorque detection 2 NC (NC Contact, OFF: Torque detection)	Yes	Yes	Yes	Yes	6-46
1A	During reverse run (ON: During reverse run)	Yes	Yes	Yes	Yes	6-75
1B	During baseblock 2 (OFF: During baseblock)	Yes	Yes	Yes	Yes	6-75
1C	Motor selection (ON: Motor 2 selected)	Yes	Yes	Yes	Yes	6-76
1D	During regenerative operation	No	No	No	Yes	6-76
1E	Restart enabled (ON: Restart enabled)	Yes	Yes	Yes	Yes	6-58
1F	Motor overload (OL1, including OH3) pre-alarm (ON: 90% or more of the detection level)	Yes	Yes	Yes	Yes	6-49
20	Inverter overheat (OH) pre-alarm (ON: Temperature exceeds L8-02 setting)	Yes	Yes	Yes	Yes	6-60
30	During torque limit (current limit) (ON: During torque limit)	No	No	Yes	Yes	6-118
31	During speed limit	No	No	No	Yes	6-118
32	Activated if the speed control circuit (ASR) is operating for torque control. The ASR output becomes the torque reference. The motor is rotating at the speed limit.	No	No	No	Yes	6-118
33	Zero-servo end (ON: Zero-Servo completed)	No	No	No	Yes	6-125
37	During run 2 (ON: Frequency output, OFF: Base block, DC injection braking, initial excitation, operation stop)	Yes	Yes	Yes	Yes	6-74
38	Drive enabled	Yes	Yes	Yes	Yes	6-76

■ Analog Inputs: H3

Parameter Number	Name	Description	Setting Range	Factory Setting	Change during Operation	Control Methods				MEMO-BUS Register	Page
	Display					V/f	V/f with PG	Open Loop Vector	Closed Loop Vector		
H3-01	Multi-function analog input terminal A1 signal level selection	Sets the analog input A1 signal level. 0: 0 to +10V (11 bit) 1: -10V to +10V (11 bit plus sign)	0 or 1	0	No	A	A	A	A	410H	6-26
	Term A1 Signal										
H3-02	Gain (terminal A1)	Sets the frequency as a percentage of the maximum output frequency, when 10 V is input.	0.0 to 1000.0	100.0%	Yes	A	A	A	A	411H	6-26
	Terminal A1 Gain										
H3-03	Bias (terminal A1)	Sets the frequency as a percentage of the maximum frequency, when 0 V is input.	-100.0 to +100.0	0.0%	Yes	A	A	A	A	412H	6-26
	Terminal A1 Bias										
H3-08	Multi-function analog input terminal A2 signal level selection	Sets the analog input A2 signal level. 0: 0 to +10V (11 bit). 1: -10V to +10V (11 bit plus sign). 2: 4 to 20 mA (9-bit input). Switch current and voltage input using the switch S1 on the control terminal board.	0 to 2	2	No	A	A	A	A	417H	6-26
	Term A2 Signal										
H3-09	Multi-function analog input terminal A2 function selection	Selects the multi-function analog input function for terminal A2. Refer to the table below. If H3-13 is set to 1, H3-09 selects the function for analog input A1.	0 to 1F	0	No	A	A	A	A	418H	6-26
	Terminal A2 Sel										
H3-10	Gain (terminal A2)	Sets the input level when terminal A2 input is 10 V (20 mA) according to the 100% value of the function set in parameter H3-09.	0.0 to 1000.0	100.0%	Yes	A	A	A	A	419H	6-26
	Terminal A2 Gain										
H3-11	Bias (terminal A2)	Sets the input level when terminal A2 is 0 V (4 mA) according to the 100% value of the function set in parameter H3-09.	-100.0 to +100.0	0.0%	Yes	A	A	A	A	41AH	6-26
	Terminal A2 Bias										
H3-12	Analog input filter time constant	Sets primary delay filter time constant for the two analog input terminals (A1 and A2). Effective for noise control etc.	0.00 to 2.00	0.03 s	No	A	A	A	A	41BH	6-26
	Filter Avg Time										
H3-13	Terminal A1/A2 switching	0: Use terminal A1 analog input as main frequency reference. 1: Use terminal A2 analog input as main frequency reference. Terminal A1 becomes multi functional. Its function can be selected in parameter H3-09.	0 or 1	0	No	A	A	A	A	41CH	6-8
	TA1/TA2 Select										

H3-09 Settings

Setting Value	Function	Contents (100%)	Control Methods				Page
			V/f	V/f with PG	Open Loop Vector	Closed Loop Vector	
0	Frequency bias	Maximum output frequency	Yes	Yes	Yes	Yes	6-27
1	Frequency gain	Frequency reference (voltage) command value	Yes	Yes	Yes	Yes	6-27
2	Auxiliary frequency reference (is used as frequency reference 2)	Maximum output frequency	Yes	Yes	Yes	Yes	6-7
4	Voltage bias	Motor rated voltage (E1-05)	Yes	Yes	No	No	-
5	Accel/decel time gain	Set acceleration and deceleration times (C1-01 to C1-08)	Yes	Yes	Yes	Yes	6-21
6	DC injection braking current	Inverter rated output current	Yes	Yes	Yes	No	6-18
7	Overtorque/undertorque detection level	Motor rated torque for vector control Inverter rated output current for V/f control	Yes	Yes	Yes	Yes	6-48
8	Stall prevention level during run	Inverter rated output current	Yes	Yes	No	No	6-45
9	Frequency reference lower limit level	Maximum output frequency	Yes	Yes	Yes	Yes	6-30
A	Jump frequency	Maximum output frequency	Yes	Yes	Yes	Yes	6-29
B	PID feedback	Maximum output frequency	Yes	Yes	Yes	Yes	6-96
C	PID target value	Maximum output frequency	Yes	Yes	Yes	Yes	6-96
D	Frequency bias 2	Maximum output frequency	Yes	Yes	Yes	Yes	
E	Motor temperature input	-	Yes	Yes	Yes	Yes	6-50
10	Positive torque limit	Motor's rated torque	No	No	Yes	Yes	6-43
11	Negative torque limit	Motor's rated torque	No	No	Yes	Yes	6-43
12	Regenerative torque limit	Motor's rated torque	No	No	Yes	Yes	6-43
13	Torque reference/torque limit at speed control	Motor's rated torque	No	No	No	Yes	6-118
14	Torque compensation	Motor's rated torque	No	No	No	Yes	6-118
15	Positive/negative torque limit	Motor's rated torque	No	No	Yes	Yes	6-43
1F	Analog input not used.	-	Yes	Yes	Yes	Yes	-

Multi-function Analog Outputs: H4

Parameter Number	Name	Description	Setting Range	Factory Setting	Change during Operation	Control Methods				MEMO-BUS Register	Page
	Display					V/f	V/f with PG	Open Loop Vector	Closed Loop Vector		
H4-01	Monitor selection (terminal FM)	Sets the number of the monitor item to be output (U1-□□) at terminal FM. The monitors U1-04, -10 to -14, -28, -34, -39, -40 cannot be set to output at terminal FM)	1 to 38	2	No	A	A	A	A	41DH	6-77
	Terminal FM Sel										
H4-02	Gain (terminal FM)	Sets the multi-function analog output 1 (terminal FM) gain. Sets the percentage of the monitor item that is equal to 10V/20mA output at terminal FM. Note that the maximum output voltage/current is 10V/20mA.	0 to 1000.0 %	100%	Yes	Q	Q	Q	Q	41EH	4-5 6-77
	Terminal FM Gain										
H4-03	Bias (terminal FM)	Sets the multi-function analog output 1 (terminal FM) bias. Sets the percentage of the monitor item that is equal to 0V/4mA output at terminal FM. The maximum output from the terminal is 10 V/20mA.	-110 to +110%	0.0%	Yes	A	A	A	A	41FH	6-77
	Terminal FM Bias										
H4-04	Monitor selection (terminal AM)	Sets the number of the monitor item to be output (U1-□□) at terminal AM. The monitors U1-04, -10 to -14, -28, -34, -39, -40 cannot be set to be output at terminal AM).	1 to 38	3	No	A	A	A	A	420H	6-77
	Terminal AM Sel										
H4-05	Gain (terminal AM)	Set the multi-function analog output 2 (terminal AM) gain. Sets the percentage of the monitor item that is equal to 10V/20mA output at terminal AM. Note that the maximum output voltage/current is 10V/20mA.	0 to 1000.0 %	50.0%	Yes	Q	Q	Q	Q	421H	4-5 6-77
	Terminal AM Gain										
H4-06	Bias (terminal AM)	Sets the multi-function analog output 2 (terminal AM) bias. Sets the percentage of the monitor item that is equal to 0V/4mA output at terminal AM. The maximum output from the terminal is 10 V/20mA.	-110.0 to +110.0 %	0.0%	Yes	A	A	A	A	422H	6-77
	Terminal AM Bias										
H4-07	Analog output 1 signal level selection	Sets the signal output level for multi-function output 1 (terminal FM) 0: 0 to +10 V output 1: -10V to +10V output 2: 4 – 20 mA Switch current and voltage output using CN15 on the control panel	0 to 2	0	No	A	A	A	A	423H	6-77
	AO Level Select1										

Parameter Number	Name	Description	Setting Range	Factory Setting	Change during Operation	Control Methods				MEMO-BUS Register	Page
	Display					V/f	V/f with PG	Open Loop Vector	Closed Loop Vector		
H4-08	Analog output 2 signal level selection	Sets the signal output level for multi-function output 2 (terminal AM) 0: 0 to +10 V output 1: -10V to +10V output 2: 4 – 20 mA Switch current and voltage output using CN15 on the control panel	0 to 2	0	No	A	A	A	A	424H	6-77
	AO Level Select2										

MEMOBUS Communications: H5

Parameter Number	Name	Description	Setting Range	Factory Setting	Change during Operation	Control Methods				MEMO-BUS Register	Page
	Display					V/f	V/f with PG	Open Loop Vector	Closed Loop Vector		
H5-01	Station address	Sets the Inverter's node address.	0 to 20 *	1F	No	A	A	A	A	425H	6-80
	Serial Comm Adr										
H5-02	Communications speed selection	Sets the baud rate for MEMOBUS communications. 0: 1200 bps 1: 2400 bps 2: 4800 bps 3: 9600 bps 4: 19200 bps	0 to 4	3	No	A	A	A	A	426H	6-80
	Serial Baud Rate										
H5-03	Communications parity selection	Sets the parity for MEMOBUS communications. 0: No parity 1: Even parity 2: Odd parity	0 to 2	0	No	A	A	A	A	427H	6-80
	Serial Com Sel										
H5-04	Stopping method after communications error	Sets the stopping method for communications errors. 0: Deceleration to stop using the deceleration time in C1-02 1: Coast to stop 2: Emergency stop using the deceleration time in C1-09 3: Continue operation	0 to 3	3	No	A	A	A	A	428H	6-80
	Serial Fault Sel										
H5-05	Communications error detection selection	Sets whether or not a communications time-out is to be detected as a communications error. 0: Do not detect. 1: Detect	0 or 1	1	No	A	A	A	A	429H	6-80
	Serial Flt Dtct										
H5-06	Send wait time	Sets the time from the Inverter receiving data to when the Inverter starts to send.	5 to 65	5 ms	No	A	A	A	A	42AH	6-80
	Transmit WaitTIM										
H5-07	RTS control ON/OFF	Enables or disables RTS control. 0: Disabled (RTS is always ON) 1: Enabled (RTS turns ON only when sending)	0 or 1	1	No	A	A	A	A	42BH	6-80
	RTS Control Sel										

* Set H5-01 to 0 to disable Inverter responses to MEMOBUS communications.

■ Pulse Train I/O: H6

Parameter Number	Name	Description	Setting Range	Factory Setting	Change during Operation	Control Methods				MEMO-BUS Register	Page
	Display					V/f	V/f with PG	Open Loop Vector	Closed Loop Vector		
H6-01	Pulse train input function selection	Selects the pulse train input function 0: Frequency reference 1: PID feedback value 2: PID target value	0 to 2	0	No	A	A	A	A	42CH	6-7 6-29
	Pulse Input Sel										
H6-02	Pulse train input scaling	Sets the number of pulses in Hertz, that is equivalent to 100% of the input item selected in H6-01.	1000 to 32000	1440 Hz	Yes	A	A	A	A	42DH	6-7 6-29
	Pulse In Scaling										
H6-03	Pulse train input gain	Sets the input level according to 100% of the input item selected in H6-01, when a pulse train with the frequency set in H6-02 is input.	0.0 to 1000.0	100.0%	Yes	A	A	A	A	42EH	6-29
	Pulse Input Gain										
H6-04	Pulse train input bias	Sets the input level according to 100% of the input item selected in H6-01, when the pulse train frequency is 0.	-100.0 to 100.0	0.0%	Yes	A	A	A	A	42FH	6-29
	Pulse Input Bias										
H6-05	Pulse train input filter time	Sets the pulse train input delay filter time constant in seconds.	0.00 to 2.00	0.10 s	Yes	A	A	A	A	430H	6-29
	Pulse In Filter										
H6-06	Pulse train monitor selection	Select the pulse train monitor output items (value of the □□ part of U1-□□). There are two types of monitor items: Speed-related items and PID-related items.	1, 2, 5, 20, 24, 36	2	Yes	A	A	A	A	431H	6-78
	Pulse Moni Sel										
H6-07	Pulse Moni Scaling	Sets the number of pulses output in hertz when the monitor item is 100%. Sets H6-06 to 2, and H6-07 to 0, to make the pulse train monitor output synchronously to the output frequency.	0 to 32000	1440 Hz	Yes	A	A	A	A	432H	6-78
	PO Scaling										

◆ Protection Function Parameters: L

■ Motor Overload: L1

Parameter Number	Name	Description	Setting Range	Factory Setting	Change during Operation	Control Methods				MEMO-BUS Register	Page
	Display					V/f	V/f with PG	Open Loop Vector	Closed Loop Vector		
L1-01	Motor protection selection	<p>Sets whether the motor thermal overload protection function is enabled or disabled.</p> <p>0: Disabled 1: General-purpose motor protection (fan cooled motor) 2: Inverter motor protection (externally cooled motor) 3: Vector motor protection</p> <p>When the Inverter power supply is turned off, the thermal value is reset, so even if this parameter is set to 1, protection may not be effective.</p> <p>When several motors are connected to one Inverter, set to L1-01 to 0 and ensure that each motor is installed with a protection device.</p>	0 to 3	1	No	Q	Q	Q	Q	480H	4-5 6-48
	MOL Fault Select										
L1-02	Motor protection time constant	<p>Sets the electric thermal detection time in seconds units. Usually changing this setting is not necessary.</p> <p>The factory setting is 150% overload for one minute.</p> <p>When the motor's overload capability is known, also set the overload resistance protection time for when the motor is hot started.</p>	0.1 to 5.0	1.0 min	No	A	A	A	A	481H	6-48
	MOL Time Const										
L1-03	Alarm operation selection during motor overheating	<p>Selects the operation when the input motor temperature (thermistor) input exceeds the alarm detection level (1.17 V) (H3-09 must be set to E).</p> <p>0: Decelerate to stop 1: Coast to stop 2: Emergency stop using the deceleration time in C1-09. 3: Continue operation (oH3 on the Operator flashes).</p>	0 to 3	3	No	A	A	A	A	482H	6-50
	Mtr OH Alarm Sel										
L1-04	Motor overheating operation selection	<p>Selects the operation when the motor temperature (thermistor) input exceeds the overheating detection level (2.34 V) (H3-09 must be set to E).</p> <p>0: Decelerate to stop 1: Coast to stop 2: Emergency stop using the deceleration time in C1-09.</p>	0 to 2	1	No	A	A	A	A	483H	6-50
	Mtr OH Fault Sel										

Parameter Number	Name	Description	Setting Range	Factory Setting	Change during Operation	Control Methods				MEMO-BUS Register	Page
	Display					V/f	V/f with PG	Open Loop Vector	Closed Loop Vector		
L1-05	Motor temperature input filter time constant	Sets H3-09 to E and sets the delay time constant for the motor temperature (thermistor) input in seconds.	0.00 to 10.00	0.20 s	No	A	A	A	A	484H	6-50
	Mtr Temp Filter										

■ Power Loss Ride Through: L2

Parameter Number	Name	Description	Setting Range	Factory Setting	Change during Operation	Control Methods				MEMO-BUS Register	Page
	Display					V/f	V/f with PG	Open Loop Vector	Closed Loop Vector		
L2-01	Momentary power loss detection	0: Disabled (DC bus undervoltage (UV1) detection) 1: Enabled (Restarted when the power returns within the time set in L2-02. When L2-02 is exceeded, DC bus undervoltage is detected.) 2: Enabled while CPU is operating. (Restarted when power returns during control operations. Does not detect DC bus undervoltage.)	0 to 2	0	No	A	A	A	A	485H	6-52 6-127
	PwrL Selection										
L2-02	Momentary power loss ride through time	Ridethrough time, when Momentary Power Loss Selection (L2-01) is set to 1, in units of seconds.	0 to 25.5	0.1 s *1	No	A	A	A	A	486H	6-52
	PwrL Ride-through										
L2-03	Min. baseblock time	Sets the Inverter's minimum baseblock time, when the Inverter is restarted after power loss ride through. Set the time to approximately 0.7 times the motor time constant. When an overcurrent or overvoltage occurs when starting a speed search or DC injection braking, increase the set values.	0.1 to 5.0	0.2 s *1	No	A	A	A	A	487H	6-52 6-53
	PwrL Baseblock t										
L2-04	Voltage recovery time	Sets the time required to return the Inverter output voltage from 0V to normal voltage at the completion of a speed search.	0.0 to 5.0	0.3 s *1	No	A	A	A	A	488H	6-52 6-53
	PwrL V/F Ramp t										
L2-05	Undervoltage detection level	Sets the DC bus undervoltage (UV) detection level (DC bus voltage). Usually changing this setting is not necessary.	150 to 210 *2	190 V *2	No	A	A	A	A	489H	6-52 6-127
	PUV Det Level										

Parameter Number	Name	Description	Setting Range	Factory Setting	Change during Operation	Control Methods				MEMO-BUS Register	Page
	Display					V/f	V/f with PG	Open Loop Vector	Closed Loop Vector		
L2-06	Kinetic Energy Buffering deceleration time	Sets the time required to decelerate from the speed where the deceleration at momentary power loss command (Kinetic Energy Buffering) is input to zero speed.	0.0 to 200.0	0.0 s	No	A	A	A	No	48AH	6-127
	KEB Decel Time										
L2-07	Momentary recovery time	Sets the time to accelerate to the set speed after recovery from a momentary power loss.	0.0 to 25.5	0.0 s *3	No	A	A	A	No	48BH	6-127
	UV Return Time										
L2-08	Frequency reduction gain at Kinetic Energy Buffering start	Sets the reduction gain of the output frequency at the beginning of deceleration at momentary power loss (Kinetic Energy Buffering). Reduction = slip frequency before Kinetic Energy Buffering operation × L2-08 × 2	0 to 300	100%	No	A	A	A	No	48CH	6-127
	KEB Frequency										

- * 1. The factory setting depends upon the Inverter capacity. The value for a 200 V Class Inverter of 0.4 kW is given.
- * 2. These are values for a 200 V class Inverter. The value for a 400 V class Inverter is the double.
- * 3. If the setting is 0, the axis will accelerate to the specified speed using the specified acceleration time (C1-01 to C1-08).

■ Stall Prevention: L3

Parameter Number	Name	Description	Setting Range	Factory Setting	Change during Operation	Control Methods				MEMO-BUS Register	Page
	Display					V/f	V/f with PG	Open Loop Vector	Closed Loop Vector		
L3-01	Stall prevention selection during accel	0: Disabled (Acceleration as set. With a heavy load, the motor may stall.) 1: Enabled (Acceleration stopped when L3-02 level is exceeded. Acceleration starts again when the current has fallen below the stall prevention level). 2: Intelligent acceleration mode (Using the L3-02 level as a basis, acceleration is automatically adjusted. The set acceleration time is disregarded.)	0 to 2	1	No	A	A	A	No	48FH	6-22
	StallIP Accel Sel										
L3-02	Stall prevention level during accel	Sets the stall prevention during acceleration operation current level as a percentage of Inverter rated current. Effective when L3-01 is set to 1 or 2. Usually changing this setting is not necessary. Reduce the setting when the motor stalls.	0 to 200	150% *	No	A	A	A	No	490H	6-22
	StallIP Accel Lvl										
L3-03	Stall prevention limit during accel	Sets the lower limit for the stall prevention during acceleration, as a percentage of the Inverter rated current. Usually changing this setting is not necessary.	0 to 100	50%	No	A	A	A	No	491H	6-22
	StallIP CHP Lvl										

Parameter Number	Name	Description	Setting Range	Factory Setting	Change during Operation	Control Methods				MEMO-BUS Register	Page
	Display					V/f	V/f with PG	Open Loop Vector	Closed Loop Vector		
L3-04	Stall prevention selection during decel	<p>Selects the stall prevention during deceleration.</p> <p>0: Disabled (Deceleration as set. If deceleration time is too short, a DC-Bus overvoltage may result.)</p> <p>1: Enabled (Deceleration is stopped when the DC-Bus voltage exceeds the stall prevention level. Deceleration restarts when the voltage falls below the stall prevention level again.)</p> <p>2: Intelligent deceleration mode (Deceleration rate is automatically adjusted so that in Inverter can decelerate in the shortest possible time. The set deceleration time is disregarded.)</p> <p>3: Enabled (with Braking Resistor Unit)</p> <p>When a braking option (Braking Resistor, Braking Resistor Unit, Braking Unit) is used, always set to 0 or 3.</p>	0 to 3	1	No	Q	Q	Q	Q	492H	4-5 6-24
	StallP Decel Sel										
L3-05	Stall prevention selection during running	<p>Selects the stall prevention during running.</p> <p>0: Disabled (Runs as set. With a heavy load, the motor may stall.)</p> <p>1: Deceleration using deceleration time 1 (C1-02.)</p> <p>2: Deceleration using deceleration time 2 (C1-04.)</p>	0 to 2	1	No	A	A	No	No	493H	6-45
	StallP Run Sel										
L3-06	Stall prevention level during running	<p>Set the stall prevention during running operation current level as a percentage of the Inverter rated current.</p> <p>Effective when L3-05 is 1 or 2. Usually changing this setting is not necessary.</p> <p>Reduce the setting when the motor stalls.</p>	30 to 200	150% *	No	A	A	No	No	494H	6-45
	StallP Run Level										

* The given initial value is valid if Heavy Duty is selected (C6-01=0, default setting). If Normal Duty 1 or 2 is selected (C6-01=1 or 2) the initial value will be 120%.

Reference Detection: L4

Parameter Number	Name	Description	Setting Range	Factory Setting	Change during Operation	Control Methods				MEMO-BUS Register	Page
	Display					V/f	V/f with PG	Open Loop Vector	Closed Loop Vector		
L4-01	Speed agreement detection level	Effective when " $f_{out} = f_{set}$ agree 1", "Frequency detection 1" or "Frequency detection 2" is set for a multi-function output.	0.0 to 150.0 *	0.0 Hz	No	A	A	A	A	499H	6-31
	Spd Agree Level										
L4-02	Speed agreement detection width	Effective when " $f_{ref} = f_{out}$ agree 1", " $f_{out} = f_{set}$ agree 1" or "Frequency detection 1" or "Frequency detection 2" is set for a multi-function output.	0.0 to 20.0	2.0 Hz	No	A	A	A	A	49AH	6-31
	Spd Agree Width										
L4-03	Speed agreement detection level (+/-)	Effective when " $f_{out} = f_{set}$ agree 2", "Frequency detection 3" or "Frequency detection 4" is set for a multi-function output.	-150.0 to +150.0 *	0.0 Hz	No	A	A	A	A	49BH	6-31
	Spd Agree Lvl+-										
L4-04	Speed agreement detection width (+/-)	Effective when " $f_{ref} = f_{out}$ agree 2", " $f_{out} = f_{set}$ agree 2", "Frequency detection 3" or "Frequency detection 4" is set for a multi-function output.	0.0 to 20.0	2.0 Hz	No	A	A	A	A	49CH	6-31
	Spd Agree Wdh+-										
L4-05	Operation when frequency reference is missing	0: Stop (Operation follows the frequency reference.) 1: Operation continues at the frequency, set in parameter L4-06.	0 or 1	0	No	A	A	A	A	49DH	6-57
	Ref Loss Sel	Frequency reference loss means that the frequency reference value drops over 90% in 400 ms.									
L4-06	Frequency reference value at frequency reference loss	Sets the frequency reference value when the frequency reference is missing	0.0 to 100.0%	80%	No	A	A	A	A	4C2H	6-57
	Fref at Floss										

* The given setting range is valid if Heavy Duty is selected (C6-01=0, default setting). If Normal Duty 1 or 2 is selected (C6-01=1 or 2) the setting range will be 0.0 to 400.0 Hz.

Fault Restart: L5

Parameter Number	Name	Description	Setting Range	Factory Setting	Change during Operation	Control Methods				MEMO-BUS Register	Page
	Display					V/f	V/f with PG	Open Loop Vector	Closed Loop Vector		
L5-01	Number of auto restart attempts	Sets the number of auto restart attempts. Automatically restarts after a fault and conducts a speed search from the run frequency.	0 to 10	0	No	A	A	A	A	49EH	6-58
	Num of Restarts										
L5-02	Auto restart operation selection	0: No output (Fault contact is not activated.) 1: Output (Fault contact is activated.)	0 or 1	0	No	A	A	A	A	49FH	6-58
	Restart Sel										

■ Torque Detection: L6

Parameter Number	Name	Description	Setting Range	Factory Setting	Change during Operation	Control Methods				MEMO-BUS Register	Page	
	Display					V/f	V/f with PG	Open Loop Vector	Closed Loop Vector			
L6-01	Torque detection selection 1	0: Overtorque/undertorque detection disabled. 1: Overtorque detection only with speed agreement; operation continues (warning is output). 2: Overtorque detected continuously during operation; operation continues (warning is output). 3: Overtorque detection only with speed agreement; output stopped upon detection. 4: Overtorque detected continuously during operation; output stopped upon detection. 5: Undertorque detection only with speed agreement; operation continues (warning is output). 6: Undertorque detected continuously during operation; operation continues (warning is output). 7: Undertorque detection only with speed agreement; output stopped upon detection. 8: Undertorque detected continuously during operation; output stopped upon detection.	0 to 8	0	No	A	A	A	A	4A1H	6-46	
	Torq Det 1 Sel											
L6-02	Torque detection level 1	Vector control: Motor rated torque is set as 100%. V/f control: Inverter rated current is set as 100%.	0 to 300	150%	No	A	A	A	A	4A2H	6-46	
	Torq Det 1 Lvl											
L6-03	Torque detection time 1	Sets the overtorque/undertorque detection time.	0.0 to 10.0	0.1 s	No	A	A	A	A	4A3H	6-46	
	Torq Det 1 Time											
L6-04	Torque detection selection 2	See L6-01 to L6-03 for a description.	0 to 8	0	No	A	A	A	A	4A4H	6-46	
	Torq Det 2 Sel											
L6-05	Torque detection level 2		0 to 300	150%	No	A	A	A	A	A	4A5H	6-46
	Torq Det 2 Lvl											
L6-06	Torque detection time 2		0.0 to 10.0	0.1 s	No	A	A	A	A	4A6H	6-46	
	Torq Det 2 Time											

■ Torque Limits: L7

Parameter Number	Name Display	Description	Setting Range	Factory Setting	Change during Operation	Control Methods				MEMO-BUS Register	Page
						V/f	V/f with PG	Open Loop Vector	Closed Loop Vector		
L7-01	Forward drive torque limit	<p>Sets the torque limit value as a percentage of the motor rated torque. Four individual regions can be set.</p> <p>Output torque</p> <p>Positive torque</p> <p>Reverse Regen. L7-04</p> <p>Forward Regen. L7-03</p> <p>Negative torque</p> <p>Reverse L7-02</p> <p>Forward L7-01</p> <p>No. motor rotations</p>	0 to 300	200%*	No	No	No	A	A	4A7H	6-43
	Torq Limit Fwd										
L7-02	Reverse drive torque limit		0 to 300	200%*	No	No	No	A	A	4A8H	6-43
	Torq Limit Rev										
L7-03	Forward regenerative torque limit		0 to 300	200%*	No	No	No	A	A	4A9H	6-43
	Torq Lmt Fwd Rgn										
L7-04	Reverse regenerative torque limit		0 to 300	200%*	No	No	No	A	A	4AAH	6-43
	Torq Lmt Rev Rgn										
L7-06	Torque limit time constant	Sets the torque limit integration time constant	5 to 10000	200 ms	No	No	No	A	No	4ACH	6-44
	Torque Limit Time										
L7-07	Torque Limit Operation during accel/ decel	<p>Sets the torque limit operation during acceleration and deceleration.</p> <p>0: P-control (I control is added at constant speed operation)</p> <p>1: I-control</p> <p>Normally changing this setting is not necessary.</p> <p>If the torque limitation accuracy during accel/dec. has preference, I control should be selected. This may result in an increased accel./dec. time and speed deviations from the reference value.</p>	0 or 1	0	No	No	No	A	No	4C9H	6-44
	Torque Limit Sel										

* A setting value of 100% is equal to the motor rated torque.

■ Hardware Protection: L8

Parameter Number	Name	Description	Setting Range	Factory Setting	Change during Operation	Control Methods				MEMO-BUS Register	Page
	Display					V/f	V/f with PG	Open Loop Vector	Closed Loop Vector		
L8-01	Protect selection for internal DB resistor	0: Disabled (no overheating protection) 1: Enabled (overheating protection)	0 or 1	0	No	A	A	A	A	4ADH	6-59
	DB Resistor Prot										
L8-02	Overheat pre-alarm level	Sets the detection temperature for the Inverter overheat detection pre-alarm in °C. The pre-alarm detects when the cooling fin temperature reaches the set value.	50 to 130	95 °C*	No	A	A	A	A	4AEH	6-60
	OH Pre-Alarm Lvl										
L8-03	Operation selection after overheat pre-alarm	Sets the operation for when the Inverter overheat pre-alarm occurs. 0: Decelerate to stop using the deceleration time C1-02. 1: Coast to stop 2: Fast stop in fast-stop time C1-09. 3: Continue operation (Monitor display only.) A fault will be given in setting 0 to 2 and a minor fault will be given in setting 3.	0 to 3	3	No	A	A	A	A	4AFH	6-60
	OH Pre-Alarm Sel										
L8-05	Input open-phase protection selection	0: Disabled 1: Enabled (Detects power supply open-phase, power supply voltage imbalance or DC bus electrostatic capacitor deterioration.)	0 or 1	1	No	A	A	A	A	4B1H	6-60
	Ph Loss In Sel										
L8-07	Output open-phase protection selection	0: Disabled 1: Enabled, 1 Phase Observation 2: Enabled, 2 and 3 Phase Observation An output open-phase is detected at less than 5% of Inverter rated current. When the applied motor capacity is small compared to the Inverter capacity, the detection may not work properly and should be disabled.	0 or 2	0	No	A	A	A	A	4B3H	6-61
	Ph Loss Out Sel										
L8-09	Ground protection selection	0: Disabled 1: Enabled It is not recommended to use another setting than factory setting.	0 or 1	1	No	A	A	A	A	4B5H	6-61
	Ground Fault Sel										
L8-10	Cooling fan control selection	Set the ON/OFF control for the cooling fan. 0: ON when Inverter is running only 1: ON whenever power is ON	0 or 1	0	No	A	A	A	A	4B6H	6-61
	Fan On/Off Sel										

Parameter Number	Name	Description	Setting Range	Factory Setting	Change during Operation	Control Methods				MEMO-BUS Register	Page
	Display					V/f	V/f with PG	Open Loop Vector	Closed Loop Vector		
L8-11	Cooling fan control delay time	Set the time in seconds to delay turning OFF the cooling fan after the inverter STOP command is given.	0 to 300	60 s	No	A	A	A	A	4B7H	6-61
	Fan Delay Time										
L8-12	Ambient temperature	Sets the ambient temperature.	45 to 60	45 °C	No	A	A	A	A	4B8H	6-62
	Ambient Temp										
L8-15	OL2 characteristics selection at low speeds	0: OL2 characteristics at low speeds disabled. 1: OL2 characteristics at low speeds enabled.	0 or 1	1	No	A	A	A	A	4BBH	6-63
	OL2 Sel @ L-Spd	It is not recommended to use another setting than the factory setting.									
L8-18	Soft CLA selection	0: Disable 1: Enable	0 or 1	0	No	A	A	A	A	4BFH	-
	Soft CLA Sel										

* The factory setting depends upon the Inverter capacity. The value for a 200 V Class Inverter of 0.4 kW is given.

5 ◆ N: Special Adjustments

■ Hunting Prevention Function: N1

Parameter Number	Name	Description	Setting Range	Factory Setting	Change during Operation	Control Methods				MEMO-BUS Register	Page
	Display					V/f	V/f with PG	Open Loop Vector	Closed Loop Vector		
N1-01	Hunting-prevention function selection	0: Hunting-prevention function disabled 1: Hunting-prevention function enabled	0 or 1	1	No	A	A	No	No	580H	6-41
	Hunt Prev Select	The hunting-prevention function suppresses hunting when the motor is operating with a light load. If high response has the priority over vibration suppression, disable the hunting-prevention function.									
N1-02	Hunting-prevention gain	Sets the hunting-prevention gain. Normally, there is no need to change this setting. If necessary, make the adjustments as follows: • If vibration occurs with light load, increase the setting. • If the motor stalls, reduce the setting. If the setting is too large, the voltage will be too suppressed and the motor may stall.	0.00 to 2.50	1.00	No	A	A	No	No	581H	4-14 6-41
	Hunt Prev Gain										

■ Automatic Frequency Regulator: N2

Parameter Number	Name	Description	Setting Range	Factory Setting	Change during Operation	Control Methods				MEMO-BUS Register	Page
						V/f	V/f with PG	Open Loop Vector	Closed Loop Vector		
N2-01	Speed feedback detection control (AFR) gain	Sets the internal speed feedback detection control gain. Normally, there is no need to change this setting. If necessary, adjust this parameter as follows: <ul style="list-style-type: none"> • If hunting occurs, increase the set value. • If response is low, decrease the set value. Adjust the setting by 0.05 at a time, while checking the response.	0.00 to 10.00	1.00	No	No	No	A	No	584H	4-14 6-42
	AFR Gain										
N2-02	Speed feedback detection control (AFR) time constant	Set the time constant 1 to decide the rate of change in the speed feedback detection control.	0 to 2000	50 ms	No	No	No	A	No	585H	6-42
	AFR Time										
N2-03	Speed feedback detection control (AFR) time constant 2	Set the time constant 2 to decide the rate of change in the speed.	0 to 2000	750 ms	No	No	No	A	No	586H	6-42
	AFR Time 2										

■ High-slip Braking: N3

Parameter Number	Name	Description	Setting Range	Factory Setting	Change during Operation	Control Methods				MEMO-BUS Register	Page
	Display					V/f	V/f with PG	Open Loop Vector	Closed Loop Vector		
N3-01	High-slip braking deceleration frequency width	Sets the frequency width for deceleration during high-slip braking in percent, taking the maximum frequency (E1-04) as 100%.	1 to 20	5%	No	A	A	No	No	588H	6-128
	HSB Down Freq										
N3-02	High-slip braking current limit	Sets the current limit for deceleration during high-slip braking in percent, taking the motor rated current as 100%. The resulting limit must be 150% of the Inverter rated current or less.	100 to 200	150%	No	A	A	No	No	589H	6-128
	HSB Current										
N3-03	High-slip braking stop dwell time	Sets the dwell time of the output frequency for FMIN (1.5 Hz) during V/f control. Effective only during deceleration with high-slip braking.	0.0 to 10.0	1.0 s	No	A	A	No	No	58AH	6-128
	HSB Dwell Time										
N3-04	High-slip braking OL time	Set the OL time when the output frequency does not change for any reason during deceleration with high-slip braking.	30 to 1200	40 s	No	A	A	No	No	58BH	6-128
	HSB OL Time										

◆ Digital Operator Parameters: o

■ Monitor Selections: o1

Parameter Number	Name	Description	Setting Range	Factory Setting	Change during Operation	Control Methods				MEMO-BUS Register	Page
	Display					V/f	V/f with PG	Open Loop Vector	Closed Loop Vector		
o1-01	Monitor selection	Set the number of the 4rd. monitor item to be displayed in the Drive Mode. (U1-□□) (On LED operator only.)	4 to 33	6	Yes	A	A	A	A	500H	6-130
	User Monitor Sel										
o1-02	Monitor selection after power up	Sets the monitor item to be displayed when the power is turned on. 1: Frequency reference 2: Output frequency 3: Output current 4: The monitor item set for o1-01	1 to 4	1	Yes	A	A	A	A	501H	6-130
	Power-On Monitor										
o1-03	Frequency units of reference setting and monitor	Sets the units that will be set and displayed for the frequency reference and frequency monitor. 0: 0.01 Hz units 1: 0.01% units (Maximum output frequency is 100%) 2 to 39: rpm units (Set the motor poles.) 40 to 39999: User desired display Set the desired values for setting and display for the max. output frequency. □□□□□ ↑ ↑ Sets the value that is to be displayed at 100% excluding the decimal point. Sets the number of decimal places. Example: When the max. output frequency value is 200.0, set 12000	0 to 39999	0	No	A	A	A	A	502H	6-131
	Display Scaling										
o1-04	Setting unit for frequency parameters related to V/f characteristics	Set the setting unit for frequency reference-related parameters. 0: Hz 1: min ⁻¹	0 or 1	0	No	No	No	No	A	503H	6-131
	V/f Display Unit										
o1-05	LCD Display contrast adjustment	Sets the contrast on the optional LCD operator (JVOP-160). 1: light 2: 3: normal 4: 5: dark	0 to 5	3	Yes	A	A	A	A	504H	6-131
	LCD Contrast										

■ Digital Operator Functions: o2

Parameter Number	Name	Description	Setting Range	Factory Setting	Change during Operation	Control Methods				MEMO-BUS Register	Page
	Display					V/f	V/f with PG	Open Loop Vector	Closed Loop Vector		
o2-01	LOCAL/REMOTE key enable/disable	Enables/Disables the Digital Operator Local/Remote key 0: Disabled 1: Enabled (Switches between the Digital Operator and the parameter settings b1-01, b1-02.)	0 or 1	1	No	A	A	A	A	505H	6-131
	Local/Remote Key										
o2-02	STOP key during control circuit terminal operation	Enables/Disables the Stop key in the run mode. 0: Disabled (When the run command is issued from an external terminal, the Stop key is disabled.) 1: Enabled (Effective even during run.)	0 or 1	1	No	A	A	A	A	506H	6-131
	Oper Stop Key										
o2-03	User parameter initial value	Clears or stores user initial values. 0: Stores/not set 1: Begins storing (Records the set parameters as user initial values.) 2: All clear (Clears all recorded user initial values) When the set parameters are recorded as user initial values, 1110 will be set in A1-03.	0 to 2	0	No	A	A	A	A	507H	6-131
	User Defaults										
o2-04	kVA selection	Do not set unless after replacing the control board. (Refer to page 5-72 for the setting values).	0 to FF	0	No	A	A	A	A	508H	6-131
	Inverter Model #										
o2-05	Frequency reference setting method selection	When the frequency reference is set on the Digital Operator frequency reference monitor, sets whether the Enter key is necessary or not. 0: Enter key needed 1: Enter key not needed When set to 1, the Inverter accepts the frequency reference without Enter key operation.	0 or 1	0	No	A	A	A	A	509H	6-131
	Operator M.O.P.										
o2-06	Operation selection when digital operator is disconnected	Sets the operation when the Digital Operator is disconnected. 0: Operation continues even if the Digital Operator is disconnected. 1: OPR is detected at Digital Operator disconnection. Inverter output is switched off, and the fault contact is operated.	0 or 1	0	No	A	A	A	A	50AH	6-131
	Oper Detection										
o2-07	Cumulative operation time setting	Sets the cumulative operation time in hour units.	0 to 65535	0 hr	No	A	A	A	A	50BH	6-132
	Elapsed Time Set										

Parameter Number	Name	Description	Setting Range	Factory Setting	Change during Operation	Control Methods				MEMO-BUS Register	Page
	Display					V/f	V/f with PG	Open Loop Vector	Closed Loop Vector		
o2-08	Cumulative operation time selection	0: Accumulated inverter power on time. 1: Accumulated inverter run time.	0 or 1	1	No	A	A	A	A	50CH	6-132
	Elapsed Time Run										
o2-09	Initialize Mode	2: Europe	2	2	No	A	A	A	A	50DH	-
	InitModeSet										
o2-10	Fan operation time setting	Sets the initial value of the fan operation time. The operation time is accumulated starting from this set value.	0 to 65535	0 hr	No	A	A	A	A	50EH	6-132
	Fan ON Time Set										
o2-12	Fault trace initialize	0: No initialisation 1: Initialize (= zero clear) after setting "1" o2-12 will be returned to "0"	0 or 1	0	No	A	A	A	A	510H	6-132
	Fault Trace Init										
o2-14	kWh monitor initialize	0: No initialisation 1: Initialize (= zero clear) after setting "1" o2-14 will be returned to "0"	0 or 1	0	No	A	A	A	A	512H	6-132
	kWh Monitor Init										

■ Copy Function: o3

Parameter Number	Name	Description	Setting Range	Factory Setting	Change during Operation	Control Methods				MEMO-BUS Register	Page
	Display					V/f	V/f with PG	Open Loop Vector	Closed Loop Vector		
o3-01	Copy function selection	0: Normal operation 1: READ (Inverter to Operator) 2: COPY (Operator to Inverter) 3: Verify (compare)	0 to 3	0	No	A	A	A	A	515H	6-132
	Copy Function Sel										
o3-02	Read permission selection	0: READ prohibited 1: READ permitted	0 or 1	0	No	A	A	A	A	516H	6-132
	Copy Allowable										

■T: Motor Autotuning

Parameter Number	Name	Description	Setting Range	Factory Setting	Change during Operation	Control Methods				MEMO-BUS Register	Page
	Display					V/f	V/f with PG	Open Loop Vector	Closed Loop Vector		
T1-00	Motor 1/2 selection	Sets the parameter group, in which the autotuned motor parameters are stored. 1: E1 to E2 (motor 1) 2: E3 to E4 (motor 2) Displayed only if a digital input is set to "Motor 1/2 selection" (H1-□□=16).	1 or 2	1	No	Yes	Yes	Yes	Yes	700H	4-8
	Select Motor										
T1-01	Autotuning mode selection	Sets the autotuning mode. 0: Rotating autotuning 1: Non-rotating autotuning 2: Non-rotating autotuning for line-to-line resistance only	0 to 2 *1	0	No	Yes	Yes	Yes	Yes	701H	4-8 4-11
	Tuning Mode Sel										
T1-02	Motor output power	Sets the output power of the motor in kilowatts.	0.00 to 650.00	0.40 kW *2	No	Yes	Yes	Yes	Yes	702H	4-11
	Mtr Rated Power										
T1-03	Motor rated voltage	Sets the rated voltage of the motor.	0 to 255.0 *3	200.0 V *3	No	No	No	Yes	Yes	703H	4-11
	Rated Voltage										
T1-04	Motor rated current	Sets the rated current of the motor.	0.32 to 6.40 *4	1.90 A *2	No	Yes	Yes	Yes	Yes	704H	4-11
	Rated Current										
T1-05	Motor base frequency	Sets the base frequency of the motor.	0 to 150.0 *5	50.0 Hz	No	No	No	Yes	Yes	705H	4-11
	Rated Frequency										
T1-06	Number of motor poles	Sets the number of motor poles.	2 to 48 poles	4 poles	No	No	No	Yes	Yes	706H	4-11
	Number of Poles										
T1-07	Motor base speed	Sets the base speed of the motor in r/min.	0 to 24000	1750 r/min	No	No	No	Yes	Yes	707H	4-11
	Rated Speed										
T1-08	Number of PG pulses	Sets the number of PG pulses per revolution.	0 to 60000	1024	No	No	No	No	Yes	708H	4-11
	PG Pulses/Rev										

* 1. Set T1-02 and T1-04 when 2 is set for T1-01. For V/f control or V/f control with PG a set value 2 is possible only.

* 2. The factory setting depends on the Inverter capacity. (The value for a 200 V Class Inverter for 0.4 kW is given.)

* 3. These are values for a 200 V class Inverter. Values for a 400 V class Inverter are double.

* 4. The setting range is from 10% to 200% of the Inverter rated output current. (The value for a 200 V Class Inverter for 0.4 kW is given.)

* 5. The given setting range is valid if Heavy Duty is selected (C6-01=0, default setting). If Normal Duty 1 or 2 is selected (C6-01=1 or 2) the setting range will be 0.0 to 400.0 Hz.

◆ U: Monitor Parameters

■ Status Monitor Parameters: U1

Parameter Number	Name	Description	Output Signal Level During Multi-Function Analog Output	Min. Unit	Control Methods				MEMO-BUS Register
	Display				V/f	V/f with PG	Open Loop Vector	Closed Loop Vector	
U1-01	Frequency reference	Monitors/sets the frequency reference value.*	10 V: Max. frequency (0 to ± 10 V possible)	0.01 Hz	Yes	Yes	Yes	Yes	40H
	Frequency Ref								
U1-02	Output frequency	Monitors the output frequency.*	10 V: Max. frequency (0 to ± 10 V possible)	0.01 Hz	Yes	Yes	Yes	Yes	41H
	Output Freq								
U1-03	Output current	Monitors the output current.	10 V: Inverter rated output current (0 to +10 V, absolute value output)	0.01A	Yes	Yes	Yes	Yes	42H
	Output Current								
U1-04	Control method	Displays the current control method.	(Cannot be output.)	-	Yes	Yes	Yes	Yes	43H
	Control Method								
U1-05	Motor speed	Monitors the detected motor speed.*	10 V: Max. frequency (0 to ± 10 V possible)	0.01 Hz	No	Yes	Yes	Yes	44H
	Motor Speed								
U1-06	Output voltage	Monitors the output voltage reference value.	10 V: 200 VAC (400 VAC) (0 to +10 V output)	0.1 V	Yes	Yes	Yes	Yes	45H
	Output Voltage								
U1-07	DC bus voltage	Monitors the main DC bus voltage.	10 V: 400 VDC (800 VDC) (0 to +10 V output)	1 V	Yes	Yes	Yes	Yes	46H
	DC Bus Voltage								
U1-08	Output power	Monitors the output power (internally detected value).	10 V: Inverter capacity (max. applicable motor capacity) (0 to ± 10 V possible)	0.1 kW	Yes	Yes	Yes	Yes	47H
	Output kWatts								
U1-09	Torque reference	Monitors the internal torque reference value for open vector control.	10 V: Motor rated torque (0 to ± 10 V possible)	0.1%	No	No	Yes	Yes	48H
	Torque Reference								

* The unit is set in o1-03 (frequency units of reference setting and monitor)

Parameter Number	Name	Description	Output Signal Level During Multi-Function Analog Output	Min. Unit	Control Methods				MEMO-BUS Register
	Display				V/f	V/f with PG	Open Loop Vector	Closed Loop Vector	
U1-10	Input terminal status	Shows input ON/OFF status. U1-10=##### 1: FWD command (S1) is ON 1: REV command (S2) is ON 1: Multi input 1 (S3) is ON 1: Multi input 2 (S4) is ON 1: Multi input 3 (S5) is ON 1: Multi input 4 (S6) is ON 1: Multi input 5 (S7) is ON	(Cannot be output.)	-	Yes	Yes	Yes	Yes	49H
	Input Term Sts								
U1-11	Output terminal status	Shows output ON/OFF status. U1-11=##### 1: Multi-function contact output 1 (M1-M2) is ON 1: Multi-function contact output 2 (M3-M4) is ON 1: Multi-function contact output 3 (M5-M6) is ON Not used (Always 0). 1: Error output (MA/MB-MC) is ON	(Cannot be output.)	-	Yes	Yes	Yes	Yes	4AH
	Output Term Sts								
U1-12	Operation status	Inverter operating status. U1-12=##### Run 1: Zero speed 1: Reverse 1: Reset signal input 1: Speed agree 1: Inverter ready 1: Minor fault 1: Major fault	(Cannot be output.)	-	Yes	Yes	Yes	Yes	4BH
	Int Ctl Sts 1								
U1-13	Cumulative operation time	Monitors the total operating time of the Inverter. The initial value and the operating time/power ON time selection can be set in o2-07 and o2-08.	(Cannot be output.)	1 hr	Yes	Yes	Yes	Yes	4CH
	Elapsed Time								
U1-14	Software No. (flash memory)	(Manufacturer's ID number)	(Cannot be output.)	-	Yes	Yes	Yes	Yes	4DH
	FLASH ID								
U1-15	Terminal A1 input level	Monitors the input level of analog input A1. A value of 100% corresponds to 10V input.	10 V: 100% (0 to ± 10 V possible)	0.1%	Yes	Yes	Yes	Yes	4EH
	Term A1 Level								

Parameter Number	Name	Description	Output Signal Level During Multi-Function Analog Output	Min. Unit	Control Methods				MEMO-BUS Register
	Display				V/f	V/f with PG	Open Loop Vector	Closed Loop Vector	
U1-16	Terminal A2 input level	Monitors the input level of analog input A2. A value of 100% corresponds to 10V/20mA input.	10 V/20mA: 100% (0 to ±10 V possible)	0.1%	Yes	Yes	Yes	Yes	4FH
	Term A2 Level								
U1-18	Motor secondary current (Iq)	Monitors the calculated value of the motor secondary current.	10 V: Motor rated current) (0 to ±10 V output)	0.1%	Yes	Yes	Yes	Yes	51H
	Mot SEC Current	The motor rated current corresponds to 100%.							
U1-19	Motor excitation current (Id)	Monitors the calculated value of the motor excitation current.	10 V: Motor rated current) (0 to ±10 V output)	0.1%	No	No	Yes	Yes	52H
	Mot EXC current	The motor rated current corresponds to 100%.							
U1-20	Frequency reference after soft-starter	Monitors the frequency reference after the soft starter. This frequency value does not include compensations, such as slip compensation.	10 V: Max. frequency (0 to ± 10 V possible)	0.01Hz	Yes	Yes	Yes	Yes	53H
	SFS Output	The unit is set in o1-03.							
U1-21	ASR input	Monitors the input to the speed control loop.	10 V: Max. frequency (0 to ± 10 V possible)	0.01%	No	Yes	No	Yes	54H
	ASR Input	The maximum frequency corresponds to 100%.							
U1-22	ASR output	Monitors the output from the speed control loop.	10 V: Max. frequency (0 to ± 10 V possible)	0.01%	No	Yes	No	Yes	55H
	ASR output	The maximum frequency corresponds to 100%.							
U1-24	PID feedback value	Monitors the feedback value when PID control is used.	10 V: 100% feedback value (0 to ± 10 V possible)	0.01%	Yes	Yes	Yes	Yes	57H
	PID Feedback								
U1-25	DI-16H2 Input Status	Monitors the reference value from a DI-16H2 option card.	(Cannot be output.)	-	Yes	Yes	Yes	Yes	58H
	DI-16 Reference	The value will be displayed in binary or BCD depending on user constant F3-01.							
U1-26	Output voltage reference (Vq)	Monitors the Inverter internal voltage reference for motor secondary current control.	10 V: 200 VAC (400 VAC) (0 to ± 10 V possible)	0.1 V	No	No	Yes	Yes	59H
	Voltage Ref(Vq)								
U1-27	Output voltage reference (Vd)	Monitors the Inverter internal voltage reference for motor excitation current control.	10 V: 200 VAC (400 VAC) (0 to ± 10 V possible)	0.1 V	No	No	Yes	Yes	5AH
	Voltage Ref(Vd)								
U1-28	Software No. (CPU)	(Manufacturer's CPU software No.)	(Cannot be output.)	-	Yes	Yes	Yes	Yes	5BH
	CPU ID								

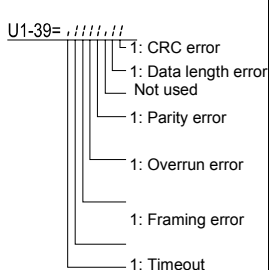
Parameter Number	Name	Description	Output Signal Level During Multi-Function Analog Output	Min. Unit	Control Methods				MEMO-BUS Register
	Display				V/f	V/f with PG	Open Loop Vector	Closed Loop Vector	
U1-29	kWh Lower four digits	Shows the consumed energy in kWh. U1-29 shows the lower four digits, U1-30 shows the upper five digits.	(Cannot be output.)	0.1 kWh	Yes	Yes	Yes	Yes	5CH
	kWh Lower 4 dig								
U1-30	kWh Higher five digits	□□□□□ □□□.□	(Cannot be output.)	1 MW	Yes	Yes	Yes	Yes	5DH
	kWh Upper 5 dig	U1-30 U1-29							
U1-32	ACR output of q axis	Monitors the current control output value for the motor secondary current.	10 V: 100% (0 to ± 10 V possible)	0.1 %	No	No	Yes	Yes	5FH
	ACR(q) Output								
U1-33	ACR output of d axis	Monitors the current control output value for the motor excitation current.	10 V: 100% (0 to ± 10 V possible)	0.1 %	No	No	Yes	Yes	60H
	ACR(d) axis								
U1-34	OPE fault parameter	Shows the first parameter number when an OPE fault is detected.	(Cannot be output.)	-	Yes	Yes	Yes	Yes	61H
	OPE Detected								
U1-35	Zero servo movement pulses	Shows the number of PG pulses of the movement range when zero servo was activated. The shown value is the actual pulse number times 4.	(Cannot be output.)	-	No	No	No	Yes	62H
	Zero Servo Pulse								
U1-36	PID input volume	PID input volume	10 V: 100% PID input (0 to ± 10 V possible)	0.01 %	Yes	Yes	Yes	Yes	63H
	PID Input								
U1-37	PID output volume	PID control output	10 V: 100% PID output (0 to ± 10 V possible)	0.01 %	Yes	Yes	Yes	Yes	64H
	PID Output								
U1-38	PID setpoint	PID set point	10 V: 100% PID set point	0.01 %	Yes	Yes	Yes	Yes	65H
U1-39	MEMOBUS communications error code	Shows MEMOBUS errors. 	(Cannot be output.)	-	Yes	Yes	Yes	Yes	66H
	Transmit Err								
U1-40	Cooling fan operating time	Monitors the total operating time of the cooling fan. The time can be set in 02-10.	(Cannot be output.)	1 hr	Yes	Yes	Yes	Yes	67H
	FAN Elapsed Time								

■ Fault Trace

Parameter Number	Name	Description	Output Signal Level During Multi-Function Analog Output	Min. Unit	Control Methods				MEMO-BUS Register
	Display				V/f	V/f with PG	Open Loop Vector	Closed Loop Vector	
U2-01	Current fault	The content of the current fault.	(Cannot be output.)	-	Yes	Yes	Yes	Yes	80H
	Current Fault								
U2-02	Last fault	The error content of the last fault.		-	Yes	Yes	Yes	Yes	81H
	Last Fault								
U2-03	Reference frequency at fault	The reference frequency when the last fault occurred.		0.01 Hz*	Yes	Yes	Yes	Yes	82H
	Frequency Ref								
U2-04	Output frequency at fault	The output frequency when the last fault occurred.		0.01 Hz*	Yes	Yes	Yes	Yes	83H
	Output Freq								
U2-05	Output current at fault	The output current when the last fault occurred.		0.01A	Yes	Yes	Yes	Yes	84H
	Output Current								
U2-06	Motor speed at fault	The motor speed when the last fault occurred.		0.01 Hz*	No	Yes	Yes	Yes	85H
	Motor Speed								
U2-07	Output voltage reference at fault	The output reference voltage when the last fault occurred.		0.1 V	Yes	Yes	Yes	Yes	86H
	Output Voltage								
U2-08	DC bus voltage at fault	The main current DC voltage when the last fault occurred.		1 V	Yes	Yes	Yes	Yes	87H
	DC Bus Voltage								
U2-09	Output power at fault	The output power when the last fault occurred.	0.1 kW	Yes	Yes	Yes	Yes	88H	
	Output kWatts								
U2-10	Torque reference at fault	The reference torque when the last fault occurred. The motor rated torque corresponds to 100%.	0.1%	No	No	No	Yes	89H	
	Torque Reference								
U2-11	Input terminal status at fault	The input terminal status when the last fault occurred. The format is the same as for U1-10.	-	Yes	Yes	Yes	Yes	8AH	
	Input Term Sts								
U2-12	Output terminal status at fault	The output terminal status when the last fault occurred. The format is the same as for U1-11.	-	Yes	Yes	Yes	Yes	8BH	
	Output Term Sts								

Parameter Number	Name	Description	Output Signal Level During Multi-Function Analog Output	Min. Unit	Control Methods				MEMO-BUS Register
	Display				V/f	V/f with PG	Open Loop Vector	Closed Loop Vector	
U2-13	Operation status at fault	The operating status when the last fault occurred. The format is the same as for U1-12.	(Cannot be output.)	-	Yes	Yes	Yes	Yes	8CH
	Inverter Status								
U2-14	Cumulative operation time at fault	The operating time when the last fault occurred.	(Cannot be output.)	1 hr	Yes	Yes	Yes	Yes	8DH
	Elapsed Time								

* The unit is set in o1-03 (frequency units of reference setting and monitor)

■ Fault History: U3

Parameter Number	Name	Description	Output Signal Level During Multi-Function Analog Output	Min. Unit	MEMO-BUS Register
	Display				
U3-01	Last fault	The error content of 1st last fault.	(Cannot be output.)	-	90H
	Last Fault				
U3-02	Second last fault	The error content of 2nd last fault.	(Cannot be output.)	-	91H
	Fault Message 2				
U3-03	Third last fault	The error content of 3rd last fault.	(Cannot be output.)	-	92H
	Fault Message 3				
U3-04	Fourth last fault	The error content of 4th last fault.	(Cannot be output.)	-	93H
	Fault Message 4				
U3-05	Cumulative operation time at fault	The total operating time when the 1st previous fault occurred.	(Cannot be output.)	1 hr	94H
	Elapsed Time 1				
U3-06	Accumulated time of second fault	The total operating time when the 2nd previous fault occurred.	(Cannot be output.)	1 hr	95H
	Elapsed Time 2				
U3-07	Accumulated time of third fault	The total operating time when the 3rd previous fault occurred.	(Cannot be output.)	1 hr	96H
	Elapsed Time 3				
U3-08	Accumulated time of fourth/oldest fault	The total operating time when the 4th previous fault occurred.	(Cannot be output.)	1 hr	97H
	Elapsed Time 4				
U3-09 – U3-14	Fifth last to tenth last fault Fault Message 5 to 10	The error content of the 5th to 10th last fault	(Cannot be output.)	–	804 805H 806H 807H 808H 809H
U3-15 – U3-20	Accumulated time of fifth to tenth fault Elapsed Time 5 to 10	Total generating time when 5th ... 10th previous fault occurred	(Cannot be output.)	1hr	806H 80FH 810H 811H 812H 813H



The following errors are not recorded in the Fault Trace and Fault History: CPF00, 01, 02, 03, UV1, and UV2.

◆ Factory Settings that Change with the Control Method (A1-02)

Parameter Number	Name	Setting Range	Unit	Factory Setting			
				V/f Control A1-02=0	V/F with PG A1-02=1	Open Loop Vector A1-02=2	Closed Loop Vector A1-02=3
b3-01	Speed search selection	0 to 3	-	2	3	2	-
b3-02	Speed search operating current	0 to 200	1%	120	-	100	-
b8-02	Energy saving gain	0.0 to 10.0	-	-	-	0.7	1.0
b8-03	Energy saving filter time constant	0.0 to 10.0	-	-	-	0.50 *1	0.01 *1
C3-01	Slip compensation gain	0.0 to 2.5	-	0.0	-	1.0	1.0
C3-02	Slip compensation primary delay time constant	0 to 10000	1 ms	2000	-	200	-
C4-02	Torque compensation primary delay time constant	0 to 10000	1 ms	200	200	20	-
C5-01	ASR proportional gain 1	0.00 to 300.00	-	-	0.20	-	20.00
C5-02	ASR integral time 1	0.000 to 10.000	1 ms	-	0.200	-	0.500
C5-03	ASR proportional gain 2	0.00 to 300.00	-	-	0.02	-	20.00
C5-04	ASR integral time 2	0.000 to 10.000	1 ms	-	0.050	-	0.500
C5-06	ASR delay time	0.000 to 0.500	0.001	-	-	-	000.4
d5-02	Torque reference delay time	0 to 1000	1 ms	-	-	-	0
E1-07 E3-05	Mid. output frequency (VB) ^{*2}	0.0 to 150.0 *4	0.1 V	2.5	2.5	3.0	-
E1-08 E3-06	Mid. output frequency voltage (VB) ^{*2}	0.0 to 255.0 (0.0 to 510.0)	0.1 V	15.0 *2*3	15.0 *2*3	13.2	-
E1-09 E3-07	Min. output frequency (FMIN)	0.0 to 150.0 *4	0.1 Hz	1.2 *2	1.5 *2	0.5	0.0
E1-10 E3-08	Min. output frequency voltage (VMIN) ^{*2}	0.0 to 255.0 (0.0 to 510.0)	0.1 V	9.0 *2*3	9.0 *2*3	2.4	-
F1-09	Over speed detection time	0.0 to 2.0	1	-	1.0	-	0.0

* 1. The settings are 0.05 (Closed Loop Vector) / 2.00 (Open Loop vector) for inverters of 55kW or larger.

* 2. Settings vary as shown in the following tables depending on the Inverter capacity and E1-03.

* 3. The settings shown are for 200 V class Inverters. The values will double for 400 V class Inverters.

* 4. The given setting range is valid if Heavy Duty is selected (C6-01=0, default setting). If Normal Duty 1 or 2 is selected (C6-01=1 or 2) the setting range will be 0.0 to 400.0 Hz.

■ 200 V and 400 V Class Inverters of 0.4 to 1.5 kW*

Parameter Number	Unit	Factory Setting																Open Loop Vector Control	Closed Loop Vector Control
		0	1	2	3	4	5	6	7	8	9	A	B	C	D	E	F		
E1-03	-	0	1	2	3	4	5	6	7	8	9	A	B	C	D	E	F	50.0	60.0
E1-04	Hz	50.0	60.0	60.0	72.0	50.0	50.0	60.0	60.0	50.0	50.0	60.0	60.0	90.0	120.0	180.0	60.0	50.0	60.0
E1-05*	V	200.0	200.0	200.0	200.0	200.0	200.0	200.0	200.0	200.0	200.0	200.0	200.0	200.0	200.0	200.0	200.0	200.0	200.0
E1-06	Hz	50.0	60.0	50.0	60.0	50.0	50.0	60.0	60.0	50.0	50.0	60.0	60.0	60.0	60.0	60.0	60.0	50.0	60.0
E1-07*	Hz	2.5	3.0	3.0	3.0	25.0	25.0	30.0	30.0	2.5	2.5	3.0	3.0	3.0	3.0	3.0	3.0	3.0	0.0
E1-08*	V	15.0	15.0	15.0	15.0	35.0	50.0	35.0	50.0	19.0	24.0	19.0	24.0	15.0	15.0	15.0	15.0	13.2	0.0
E1-09	Hz	1.3	1.5	1.5	1.5	1.3	1.3	1.5	1.5	1.3	1.3	1.5	1.5	1.5	1.5	1.5	1.5	0.5	0.0
E1-10*	V	9.0	9.0	9.0	9.0	8.0	9.0	8.0	9.0	11.0	13.0	11.0	15.0	9.0	9.0	9.0	9.0	2.4	0.0

* The settings shown are for 200 V class Inverters. The values will double for 400 V class Inverters.

■ 200 V and 400 V Class Inverters of 2.2 to 45 kW*

Parameter Number	Unit	Factory Setting																Open Loop Vector Control	Closed Loop Vector Control
		0	1	2	3	4	5	6	7	8	9	A	B	C	D	E	F		
E1-03	-	0	1	2	3	4	5	6	7	8	9	A	B	C	D	E	F	60.0	60.0
E1-04	Hz	50.0	60.0	60.0	72.0	50.0	50.0	60.0	60.0	50.0	50.0	60.0	60.0	90.0	120.0	180.0	60.0	60.0	60.0
E1-05*	V	200.0	200.0	200.0	200.0	200.0	200.0	200.0	200.0	200.0	200.0	200.0	200.0	200.0	200.0	200.0	200.0	200.0	200.0
E1-06	Hz	50.0	60.0	50.0	60.0	50.0	50.0	60.0	60.0	50.0	50.0	60.0	60.0	60.0	60.0	60.0	60.0	60.0	60.0
E1-07*	Hz	2.5	3.0	3.0	3.0	25.0	25.0	30.0	30.0	2.5	2.5	3.0	3.0	3.0	3.0	3.0	3.0	3.0	0.0
E1-08*	V	14.0	14.0	14.0	14.0	35.0	50.0	35.0	50.0	18.0	23.0	18.0	23.0	14.0	14.0	14.0	14.0	11.0	0.0
E1-09	Hz	1.3	1.5	1.5	1.5	1.3	1.3	1.5	1.5	1.3	1.3	1.5	1.5	1.5	1.5	1.5	1.5	0.5	0.0
E1-10*	V	7.0	7.0	7.0	7.0	6.0	7.0	6.0	7.0	9.0	11.0	9.0	13.0	7.0	7.0	7.0	7.0	2.0	0.0

* The settings shown are for 200 V class Inverters. The values will double for 400 V class Inverters.

■ 200 V Class Inverters of 55 to 110 kW and 400 V Class Inverters of 55 to 300 kW*

Parameter Number	Unit	Factory Setting																Open Loop Vector Control	Closed Loop Vector Control
		0	1	2	3	4	5	6	7	8	9	A	B	C	D	E	F		
E1-03	-	0	1	2	3	4	5	6	7	8	9	A	B	C	D	E	F	60.0	60.0
E1-04	Hz	50.0	60.0	60.0	72.0	50.0	50.0	60.0	60.0	50.0	50.0	60.0	60.0	90.0	120.0	180.0	60.0	60.0	60.0
E1-05*	V	200.0	200.0	200.0	200.0	200.0	200.0	200.0	200.0	200.0	200.0	200.0	200.0	200.0	200.0	200.0	200.0	200.0	200.0
E1-06	Hz	50.0	60.0	50.0	60.0	50.0	50.0	60.0	60.0	50.0	50.0	60.0	60.0	60.0	60.0	60.0	60.0	60.0	60.0
E1-07*	Hz	2.5	3.0	3.0	3.0	25.0	25.0	30.0	30.0	2.5	2.5	3.0	3.0	3.0	3.0	3.0	3.0	3.0	0.0
E1-08*	V	12.0	12.0	12.0	12.0	35.0	50.0	35.0	50.0	15.0	20.0	15.0	20.0	12.0	12.0	12.0	12.0	11.0	0.0
E1-09	Hz	1.3	1.5	1.5	1.5	1.3	1.3	1.5	1.5	1.3	1.3	1.5	1.5	1.5	1.5	1.5	1.5	0.5	0.0
E1-10*	V	6.0	6.0	6.0	6.0	5.0	6.0	5.0	6.0	7.0	9.0	7.0	11.0	6.0	6.0	6.0	6.0	2.0	0.0

* The settings shown are for 200 V class Inverters. The values will double for 400 V class Inverters.

◆ Factory Settings that Change with the Inverter Capacity (o2-04)

■ 200 V Class Inverters

Parameter Number	Name	Unit	Factory Setting								
			0.4	0.75	1.5	2.2	3.7	5.5	7.5	11	15
-	Inverter Capacity	kW	0.4	0.75	1.5	2.2	3.7	5.5	7.5	11	15
o2-04	kVA selection	-	0	1	2	3	4	5	6	7	8
b8-03	Energy-saving filter time constant	s	0.50 (Open Loop vector)								
b8-04	Energy-saving coefficient	-	288.20	223.70	169.40	156.80	122.90	94.75	72.69	70.44	63.13
E2-01 (E4-01)	Motor rated current	A	1.90	3.30	6.20	8.50	14.00	19.60	26.60	39.7	53.0
E2-02 (E4-02)	Motor rated slip	Hz	2.90	2.50	2.60	2.90	2.73	1.50	1.30	1.70	1.60
E2-03 (E4-03)	Motor no-load current	A	1.20	1.80	2.80	3.00	4.50	5.10	8.00	11.2	15.2
E2-05 (E4-05)	Motor line-to-line resistance	W	9.842	5.156	1.997	1.601	0.771	0.399	0.288	0.230	0.138
E2-06 (E4-06)	Motor leak inductance	%	18.2	13.8	18.5	18.4	19.6	18.2	15.5	19.5	17.2
E2-10	Motor iron loss for torque compensation	W	14	26	53	77	112	172	262	245	272
L2-02	Momentary power loss ride through time	s	0.1	0.1	0.2	0.3	0.5	1.0	1.0	1.0	2.0
L2-03	Min. baseblock (BB) time	s	0.1	0.2	0.3	0.4	0.5	0.6	0.7	0.8	0.9
L2-04	Voltage recovery time	s	0.3	0.3	0.3	0.3	0.3	0.3	0.3	0.3	0.3
L8-02	Overheat pre-alarm level	°C	95	95	95	100	95	95	95	95	90

Parameter Number	Name	Unit	Factory Setting									
			18.5	22	30	37	45	55	75	90	110	
-	Inverter Capacity	kW	18.5	22	30	37	45	55	75	90	110	
o2-04	kVA selection	-	9	A	B	C	D	E	F	10	11	
b8-03	Energy-saving filter time constant	s	0.50 (Open Loop vector)					2.00 (Open Loop vector)				
b8-04	Energy-saving coefficient	-	57.87	51.79	46.27	38.16	35.78	31.35	23.10	23.10	23.10	
E2-01 (E4-01)	Motor rated current	A	65.8	77.2	105.0	131.0	160.0	190.0	260.0	260.0	260.0	
E2-02 (E4-02)	Motor rated slip	Hz	1.67	1.70	1.80	1.33	1.60	1.43	1.39	1.39	1.39	
E2-03 (E4-03)	Motor no-load current	A	15.7	18.5	21.9	38.2	44.0	45.6	72.0	72.0	72.0	
E2-05 (E4-05)	Motor line-to-line resistance	W	0.101	0.079	0.064	0.039	0.030	0.022	0.023	0.023	0.023	
E2-06 (E4-06)	Motor leak inductance	%	20.1	19.5	20.8	18.8	20.2	20.5	20.0	20.0	20.0	
E2-10	Motor iron loss for torque compensation	W	505	538	699	823	852	960	1200	1200	1200	
L2-02	Momentary power loss ride through time	s	2.0	2.0	2.0	2.0	2.0	2.0	2.0	2.0	2.0	
L2-03	Min. baseblock (BB) time	s	1.0	1.0	1.1	1.1	1.2	1.2	1.3	1.5	1.7	
L2-04	Voltage recovery time	s	0.6	0.6	0.6	0.6	0.6	1.0	1.0	1.0	1.0	
L8-02	Overheat pre-alarm level	°C	100	90	90	95	100	105	110	100	95	

■400 V Class Inverters

Parameter Number	Name	Unit	Factory Setting									
			0.4	0.75	1.5	2.2	3.7	4.0	5.5	7.5	11	15
-	Inverter Capacity	kW	0.4	0.75	1.5	2.2	3.7	4.0	5.5	7.5	11	15
o2-04	kVA selection	-	20	21	22	23	24	25	26	27	28	29
b8-03	Energy-saving filter time constant	s	0.50 (Open Loop vector)									
b8-04	Energy-saving coefficient	-	576.40	447.40	338.80	313.60	245.80	236.44	189.50	145.38	140.88	126.26
E2-01 (E4-01)	Motor rated current	A	1.00	1.60	3.10	4.20	7.00	7.00	9.80	13.30	19.9	26.5
E2-02 (E4-02)	Motor rated slip	Hz	2.90	2.60	2.50	3.00	2.70	2.70	1.50	1.30	1.70	1.60
E2-03 (E4-03)	Motor no-load current	A	0.60	0.80	1.40	1.50	2.30	2.30	2.60	4.00	5.6	7.6
E2-05 (E4-05)	Motor line-to-line resistance	W	38.198	22.459	10.100	6.495	3.333	3.333	1.595	1.152	0.922	0.550
E2-06 (E4-06)	Motor leak inductance	%	18.2	14.3	18.3	18.7	19.3	19.3	18.2	15.5	19.6	17.2
E2-10	Motor iron loss for torque compensation	W	14	26	53	77	130	130	193	263	385	440
L2-02	Momentary power loss ride through time	s	0.1	0.1	0.2	0.3	0.5	0.5	0.8	0.8	1.0	2.0
L2-03	Min. baseblock (BB) time	s	0.1	0.2	0.3	0.4	0.5	0.6	0.6	0.7	0.8	0.9
L2-04	Voltage recovery time	s	0.3	0.3	0.3	0.3	0.3	0.3	0.3	0.3	0.3	0.3
L8-02	Overheat pre-alarm level	°C	95	95	95	90	95	95	95	90	95	95

Parameter Number	Name	Unit	Factory Setting										
			18.5	22	30	37	45	55	75	90	110	132	
-	Inverter Capacity	kW	18.5	22	30	37	45	55	75	90	110	132	
o2-04	kVA selection	-	2A	2B	2C	2D	2E	2F	30	31	32	33	
b8-03	Energy-saving filter time constant	s	0.50 (Open Loop vector)					2.00 (Open Loop vector)					
b8-04	Energy-saving coefficient	-	115.74	103.58	92.54	76.32	71.56	67.20	46.20	41.22	36.23	33.18	
E2-01 (E4-01)	Motor rated current	A	32.9	38.6	52.3	65.6	79.7	95.0	130.0	156.0	190.0	223.0	
E2-02 (E4-02)	Motor rated slip	Hz	1.67	1.70	1.80	1.33	1.60	1.46	1.39	1.40	1.40	1.38	
E2-03 (E4-03)	Motor no-load current	A	7.8	9.2	10.9	19.1	22.0	24.0	36.0	40.0	49.0	58.0	
E2-05 (E4-05)	Motor line-to-line resistance	W	0.403	0.316	0.269	0.155	0.122	0.088	0.092	0.056	0.046	0.035	
E2-06 (E4-06)	Motor leak inductance	%	20.1	23.5	20.7	18.8	19.9	20.0	20.0	20.0	20.0	20.0	
E2-10	Motor iron loss for torque compensation	W	508	586	750	925	1125	1260	1600	1760	2150	2350	
L2-02	Momentary power loss ride through time	s	2.0	2.0	2.0	2.0	2.0	2.0	2.0	2.0	2.0	2.0	
L2-03	Min. baseblock (BB) time	s	1.0	1.0	1.1	1.1	1.2	1.2	1.3	1.5	1.7	1.7	
L2-04	Voltage recovery time	s	0.6	0.6	0.6	0.6	0.6	1.0	1.0	1.0	1.0	1.0	
L8-02	Overheat pre-alarm level	°C	98	78	85	85	90	90	98	108	100	110	

Parameter Number	Name	Unit	Factory Setting			
-	Inverter Capacity	kW	160	185	220	300
o2-04	kVA selection	-	34	35	36	37
b8-03	Energy-saving filter time constant	s	2.00 (Open Loop vector)			
b8-04	Energy-saving coefficient	-	30.13	30.57	27.13	21.76
E2-01 (E4-01)	Motor rated current	A	270.0	310.0	370.0	500.0
E2-02 (E4-02)	Motor rated slip	Hz	1.35	1.30	1.30	1.25
E2-03 (E4-03)	Motor no-load current	A	70.0	81.0	96.0	130.0
E2-05 (E4-05)	Motor line-to-line resistance	W	0.029	0.025	0.020	0.014
E2-06 (E4-06)	Motor leak inductance	%	20.0	20.0	20.0	20.0
E2-10	Motor iron loss for torque compensation	W	2850	3200	3700	4700
L2-02	Momentary power loss ride through time	-	2.0	2.0	2.0	2.0
L2-03	Min. baseblock (BB) time	s	1.8	1.9	2.0	2.1
L2-04	Voltage recovery time	s	1.0	1.0	1.0	1.0
L8-02	Overheat pre-alarm level	°C	108	95	100	95

◆ Parameter Initial Values that Change With the Setting of C6-01

Parameter Number	Name	Initial Value	
		C6-01=0 (Heavy Duty)	C6-01=1 or 2 (Normal Duty 1 or 2)
C6-02	Carrier frequency selection	1	Depends on the inverter rated power
L3-02	Stall prevention at acceleration level	150%	120%
L3-06	Stall prevention during running operation level	150%	120%
L8-15	OL2 characteristics at low speed	0 (Disabled)	1 (Enabled)

■Parameter Setting Ranges that Change With the Setting of C6-01

Parameter Number	Name	Setting Range	
		C6-01=0 (Heavy Duty)	C6-01=1 or 2 (Normal Duty 1 or 2)
C6-02	Carrier frequency selection	0,6,F	0 to 6, F (depends on the inverter rated power)
b5-15	PID sleep function operation level	Upper Limit = 150.0 Hz	Upper Limit = 400.0 Hz
b6-01	Dwell frequency at start		
b6-03	Dwell frequency at stop		
C1-11	Accel./Decel. time switching frequency		
C5-07	ASR gain switching frequency		
d3-01	Jump frequency 1		
d3-02	Jump frequency 2		
d3-03	Jump frequency 3		
d6-02	Field weakening limit		
E1-04	Maximum output frequency		
E1-06	Base frequency		
E1-07	Middle output frequency		
E1-09	Minimum output frequency		
E1-11	Middle output frequency 2		
E3-02	Motor 2 maximum output frequency		
E3-04	Motor 2 base frequency		
E3-05	Motor 2 middle output frequency		
E3-07	Motor 2 minimum output frequency		
L4-01	Frequency detection level	-150.0 to +150.0 Hz	-400.0 to 400.0 Hz
L4-03	Frequency detection bandwidth		



5



6

Parameter Settings by Function

Application and Overload Selections	6-2
Frequency Reference	6-7
Run Command Input Methods	6-12
Stopping Methods	6-14
Acceleration and Deceleration Characteristics	6-19
Adjusting Frequency References	6-26
Speed Limit (Frequency Reference Limits).....	6-30
Frequency Detection.....	6-31
Improving the Operation Performance	6-33
Machine Protection	6-43
Automatic Restart	6-52
Inverter Protection.....	6-59
Input Terminal Functions	6-64
Output Terminal Functions.....	6-74
Monitor Parameters	6-77
Individual Functions	6-80
Digital Operator Functions	6-130
Option Cards.....	6-138

Application and Overload Selections

◆ Select the Overload to Suit the Application

Set C6-01 (Heavy Duty: constant torque, Normal Duty: High carrier, variable torque) depending on the application. The setting ranges for the Inverter carrier frequency, overload capability and maximum output frequency depend on the setting of C6-01. For applications like fans and blowers (quadratic torque characteristic) set C6-01 to 1 or 2 (Normal Duty 1 or 2). For applications with a constant torque characteristic set C6-01 to 0 (Heavy Duty).

■ Related Parameters

Parameter No.	Name	Factory Setting	Change during Operation	Control Methods			
				V/f	V/fwith PG	Open Loop Vector	Closed Loop Vector
C6-01	Heavy/Normal Duty selection	0	No	Q	Q	Q	Q
C6-02	Carrier frequency selection	1	No	Q	Q	Q	Q
C6-03	Carrier frequency upper limit	2.0 kHz	No	A	A	A	A
C6-04	Carrier frequency lower limit	2.0 kHz	No	A	A	No	No
C6-05	Carrier frequency proportional gain	00	No	A	A	No	No

■ Difference Between Heavy Duty and Normal Duty

The characteristics of Heavy Duty (constant torque) and Normal Duty (variable torque) are shown below.

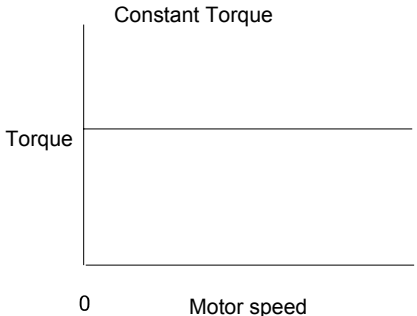
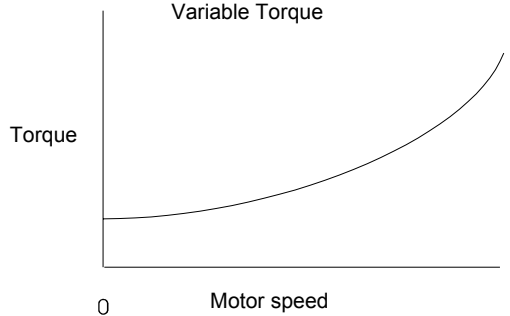
Heavy Duty / Constant Torque	Normal Duty / Variable Torque
<p style="text-align: center;">Constant Torque</p>  <p style="text-align: center;">0 Motor speed</p>	<p style="text-align: center;">Variable Torque</p>  <p style="text-align: center;">0 Motor speed</p>
<p>Constant torque means a constant load torque for all motor speed. Typical applications are pushers, conveyors, cranes, and other high friction or heavy loads. These applications may require overload capability.</p>	<p>Variable torque means that the load torque will increase as the speed increases. Typical applications are fans and pumps. Normally not much overload capability is required.</p>

■ Setting Precautions

C6-01 (Heavy/Normal Duty Selection)

The inverter supplies Heavy/Normal Duty modes Heavy Duty, Normal Duty 1 and Normal Duty 2. The setting ranges and factory settings of some parameters change with the setting of C6-01. See [page 5-74, Parameter Initial Values that Change With the Setting of C6-01](#) and [page 5-75, Parameter Setting Ranges that Change With the Setting of C6-01](#).

The table below shows the main differences of the three modes.

C6-01 Set Value	0 (Heavy Duty)	1 (Normal Duty 1)	2 (Normal Duty 2)
Inverter Current Overload Capability	150% of the Heavy Duty rated current for 1 min. * ¹	120% of the Normal Duty 1 rated current for 1 min. * ¹	120% of the Normal Duty 2 rated current for 1 min. * ¹
C6-02 (Carrier Frequency Selection)	0: Low carrier frequency, low noise 1: 2 kHz 6: 15kHz * ²	0: Low carrier low noise 1: Carrier 2 kHz 2: Carrier 5 kHz * ³ 3: Carrier 8.0 kHz * ³ 4: Carrier 10.0 kHz * ³ 5: Carrier 12.5 kHz * ³ 6: Carrier 15 kHz * ³ F: User-set * ³	
E1-04 and E3-02 (Max. Output Frequency)	150 Hz		400 Hz
L3-02 (Stall Prevention Level During Acceleration)	150%		120%
L3-06 (Stall Prevention Level During Operation)	150%		120%
L8-15 (OL2 Characteristics at low Speed)	0 (Disabled)		1 (Enabled)

* 1. The rated current depends on the Heavy/Normal Duty selection. (See [page -2, Specifications by Model](#) for details)

* 2. If the carrier frequency in Heavy Duty mode is set to a higher value than 2.5kHz, a current derating must be considered.

* 3. The factory setting and the maximum carrier frequency depend on the inverter capacity. (See [page -2, Specifications by Model](#) for details)

Carrier Frequency Selection

When selecting the carrier frequency, observe the following precautions:

- Adjust the carrier frequency according to the cases shown below.
 - If the wiring distance between Inverter and motor is long: Set the carrier frequency low. (Use the following values as guidelines.

Wiring Length	50 m or less	100 m or less	Over 100 m
C6-02 (carrier frequency) setting	0 to 6 (15 kHz)	0 to 4 (10 kHz)	0 to 2 (5 kHz)

- If speed and torque vary at low speeds: Lower the carrier frequency.
- If Inverter noise is affecting peripheral devices: Lower the carrier frequency.
- If leakage current from the Inverter is large: Lower the carrier frequency.
- If metallic noise from the motor is large: Increase the carrier frequency.

- When using V/f control or V/f control with PG, the carrier frequency can be set to vary depending on the output frequency, as shown in the following diagram by setting C6-03 (Carrier Frequency Upper Limit), C6-04 (Carrier Frequency Lower Limit), and C6-05 (Carrier Frequency Proportional Gain).

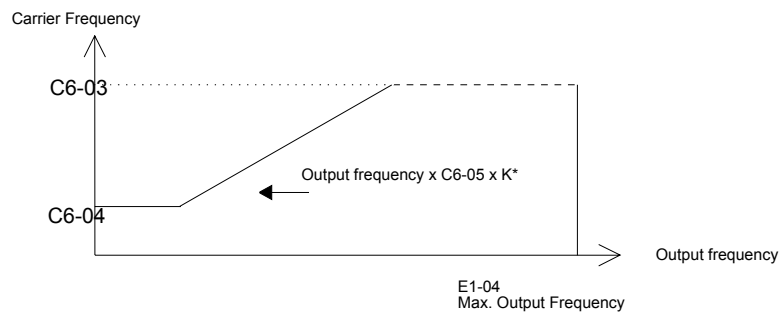

*K is the coefficient determined by the set value in C6-03.
 C6-03 \geq 10.0 kHz: K=3
 10.0 kHz > C6-03 \geq 5.0 kHz: K=2
 5.0 kHz > C6-03: K=1

Fig 6.1 Variable Carrier Frequency

- With Open Loop and Closed Loop Vector control, the carrier frequency is fixed by the Carrier Frequency Upper Limit in C6-03 if user-set, or by the carrier frequency set in C6-02.
- To fix the carrier frequency, set C6-03 and C6-04 to the same value, or set C6-05 to 0.
- If the settings are as shown below, OPE11 (Data setting error) will occur.
 - If Carrier Frequency Proportional Gain (C6-05) > 6 and C6-03 < C6-04.
 - If C6-01 = 0 and Carrier Frequency Selection C6-02 is set from 2 to E.
 - If C6-01 = 1 and Carrier Frequency Selection C6-02 is set from 7 to E.

■ Carrier Frequency and Inverter Overload Capability

The inverter overload capability depends among other things on the carrier frequency setting. If the carrier frequency setting is higher than the factory setting, the overload current capability must be reduced.

Heavy Duty (C6-01=0)

The default carrier frequency for the Heavy Duty mode is 2 kHz. The overload capability is 150% of the Heavy Duty rated current for 1 minute.

If the carrier frequency is increased, a derating for the continuous output current like shown on [Fig 6.2](#) must be considered. The overload capability (OL2 Level) does not change. It will be 150% of the derated current for 1 min.

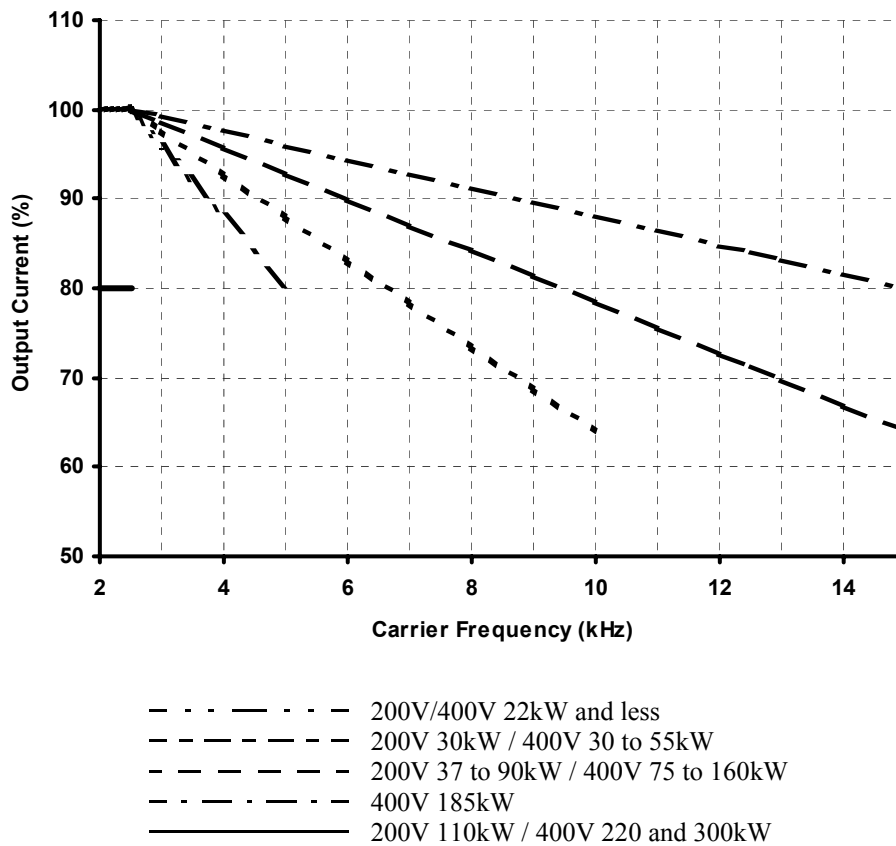

Fig 6.2 Current Derating in Heavy Duty Mode

Normal Duty 1 (C6-01=1)

The default carrier frequency for the Normal Duty 1 mode depends on the inverter capacity. The overload capability is 120% of the Normal Duty 1 rated current for 1 minute.

If the carrier frequency is set to a higher value than the factory setting, the overload capability is reduced like shown in *Fig 6.3*.

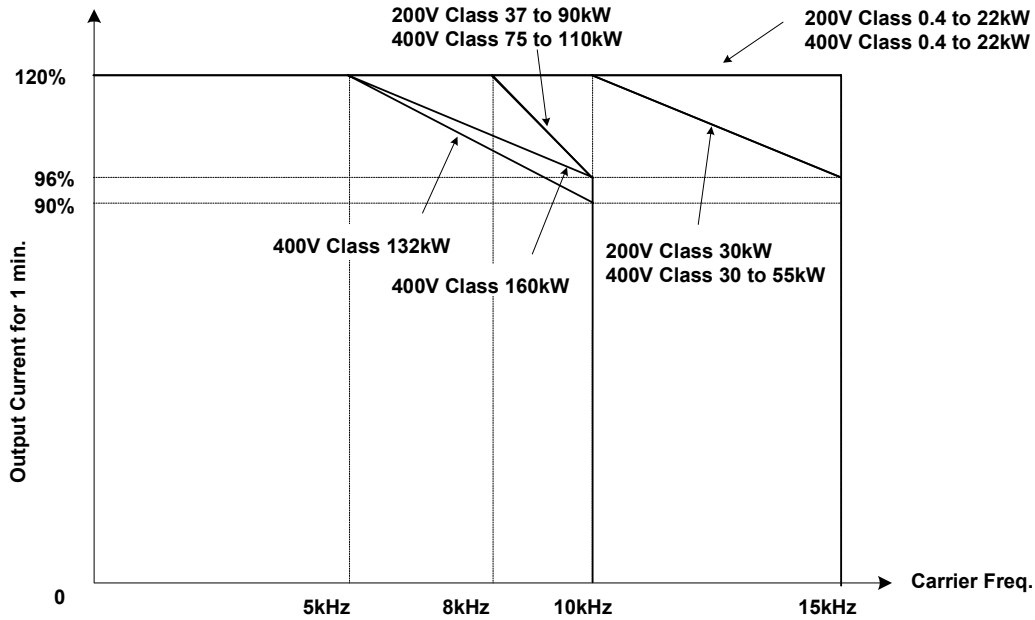

Fig 6.3 Overload Capability in Normal Duty 1 Mode

Normal Duty 2 (C6-01=2)

In the Normal Duty 2 mode the maximum carrier frequency is decreased compared to the Normal Duty 1 mode but the short term overload capability is increased. Refer to *Fig 6.4* for the overload capability of both modes.

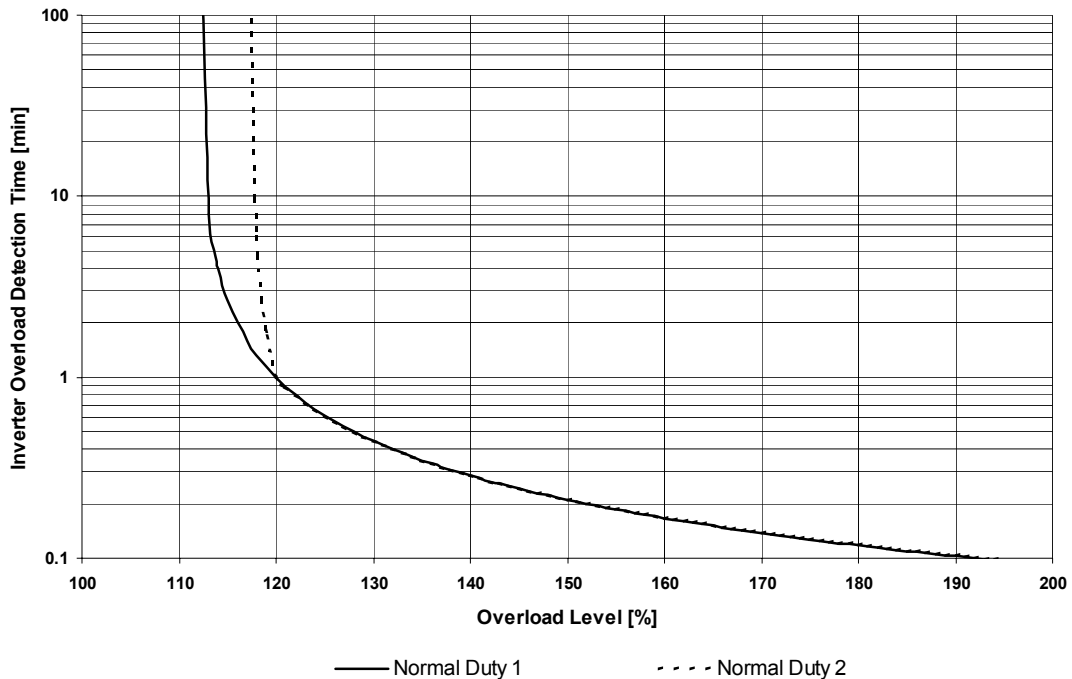

Fig 6.4 Normal Duty 1 and 2 Inverter Overload Detection Curve

Frequency Reference

◆ Selecting the Frequency Reference Source

Set parameter b1-01 to select the frequency reference source.

■ Related Parameters

Parameter No.	Name	Factory Setting	Change during Operation	Control Methods			
				V/f	V/f with PG	Open Loop Vector	Closed Loop Vector
b1-01	Frequency reference source selection	1	No	Q	Q	Q	Q
H3-09	Analog input 2 function selection	0	No	A	A	A	A
H3-13	Terminal A1/A2 main reference input switching	0	No	A	A	A	A
H6-01	Pulse train input function selection	0	No	A	A	A	A
H6-02	Pulse train input scaling	1440 Hz	No	A	A	A	A

■ Input the Frequency Reference from the Digital Operator

When b1-01 is set to 0, you can input the frequency reference from the Digital Operator.

For details on setting the frequency reference, refer to [page 3-1, Digital Operator and Modes](#).

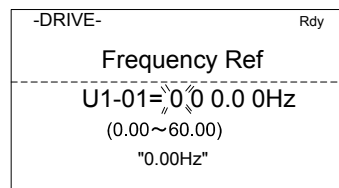

Fig 6.5 Frequency Setting Display

Inputting the Frequency Reference Using Voltage (Analog Setting)

When b1-01 is set to 1, you can input the frequency reference from control circuit terminal A1 (voltage input), or control circuit terminal A2 (voltage or current input).

Inputting Master Speed Frequency Reference Only

If inputting the master speed frequency reference only, input the voltage reference to control circuit terminal A1.

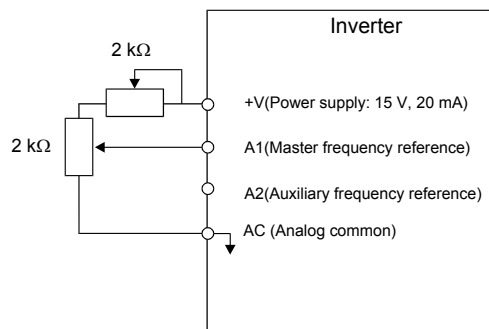

Fig 6.6 Master Speed Frequency Reference Input

2-Step Switching: Master/Auxiliary

If performing 2-step switching between master and auxiliary speed frequencies, input the master speed frequency reference to control circuit terminal A1, and input the auxiliary speed frequency reference to A2.

When terminal S3 (multi-step speed command 1) is OFF, terminal A1 input (master speed frequency reference) will be the Inverter frequency reference, and when terminal S3 is ON, terminal A2 input (auxiliary speed frequency reference) will be the Inverter frequency reference.

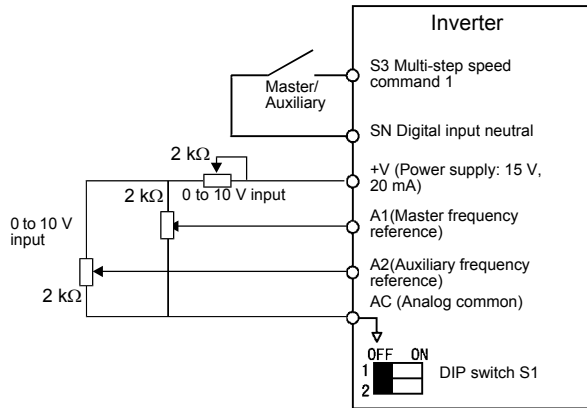

Fig 6.7 Master/Auxiliary Frequency Reference Input

Setting Precautions

When inputting a voltage signal to terminal A2, turn OFF pin 2 on DIP switch S1 to switch to voltage input (factory setting is ON).

6 ■ Inputting the Frequency Reference Using a Current Signal / Making Analog Input A1 Multifunctional

The frequency reference can be input from control circuit terminal A2 using a 4-20mA current signal. To use this function parameter H3-13 must be set to 1 (terminal A1/A2 switching).

In this case A2 becomes the master frequency input and A1 becomes multi-functional. The function for the analog input A1 can be set in parameter H3-09.

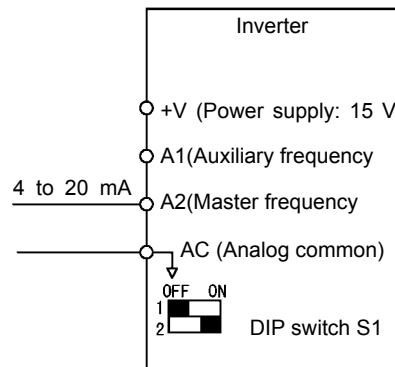

Fig 6.8 Frequency Reference Using Current

Setting Precautions

- When inputting a current signal to terminal A2, turn ON pin 2 on DIP switch S1 (factory setting: ON).

■ Setting Frequency Reference Using Pulse Train Signals

When b1-01 is set to 4, the pulse train input signal at terminal RP input is used as the frequency reference.

Set H6-01 (Pulse Train Input Function Selection) to 0 (frequency reference), and then set the reference pulse frequency that is equal to 100% of the reference value to H6-02 (Pulse Train Input Scaling).

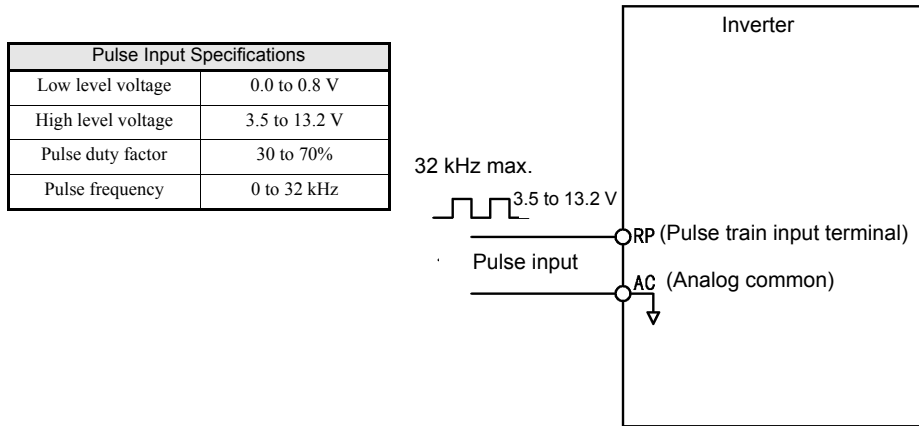

Fig 6.9 Frequency Reference Using Pulse Train Input

◆ Using Multi-Step Speed Operation

The inverter supports a multi step speed operation with a maximum of 17 speed steps, using 16 multi-step frequency references, and one jog frequency reference.

The following example of a multi-function input terminal function shows a 9-step operation using multi-step references 1 to 3 and jog frequency selection functions.

■ Related Parameters

To switch frequency references, set multi-step references 1 to 3 and the jog reference selection in the multi-function digital inputs.

Multi-function Digital Inputs (H1-01 to H1-05)

Terminal	Parameter Number	Set Value	Details
S4	H1-02	5	Multi-step speed command 3
S5	H1-03	3 (default)	Multi-step speed command 1 (Also used for master speed/auxiliary speed switching when multi-function analog input H3-09 is set to 2 (auxiliary frequency reference).)
S6	H1-04	4 (default)	Multi-step speed command 2
S7	H1-05	6 (default)	Jog frequency selection (given priority over multi-step speed command)

Combining Multi-Step Speed References and Digital Inputs

You can change the selected frequency reference by combining the ON/OFF status of S4 to S7 (digital input terminals). The following table shows the possible combinations.

Speed	Multi-step Speed Command 1	Multi-step Speed Command 2	Multi-step Speed Command 3	Jog Frequency Selection	Selected Frequency
1	OFF	OFF	OFF	OFF	Frequency reference 1 d1-01, master speed frequency
2	ON	OFF	OFF	OFF	Frequency reference 2 d1-02, auxiliary frequency
3	OFF	ON	OFF	OFF	Frequency reference 3 d1-03
4	ON	ON	OFF	OFF	Frequency reference 4 d1-04
5	OFF	OFF	ON	OFF	Frequency reference 5 d1-05
6	ON	OFF	ON	OFF	Frequency reference 6 d1-06
7	OFF	ON	ON	OFF	Frequency reference 7 d1-07
8	ON	ON	ON	OFF	Frequency reference 8 d1-08
17	-	-	-	ON*	Jog frequency d1-17

* Terminal S7's jog frequency selection is given priority over multi-step speed commands.

Setting Precautions

When setting analog inputs to step 1 and step 2, observe the following precautions.

- When setting terminal A1's analog input to step 1 set b1-01 to 1, when setting d1-01 (Frequency Reference 1) to step 1 set b1-01 to 0.
- When setting terminal A2's analog input to step 2 set H3-09 to 2 (auxiliary frequency reference). When setting d1-02 (Frequency Reference 2) to step 2 set H3-09 to an other setting than 2.

■ Connection Example and Time Chart

The following diagram shows a time chart and control circuit connection example for a 9-step operation.

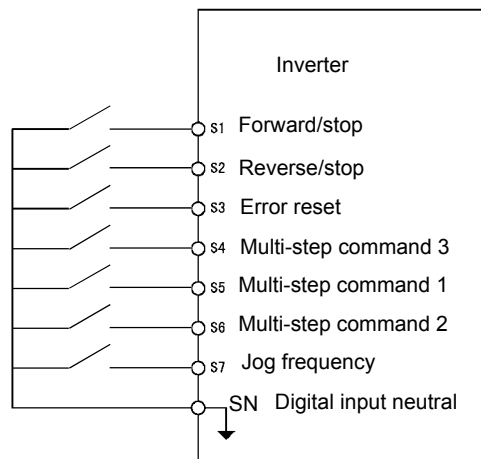

Fig 6.10 Control Circuit Configuration for 9-step Operation

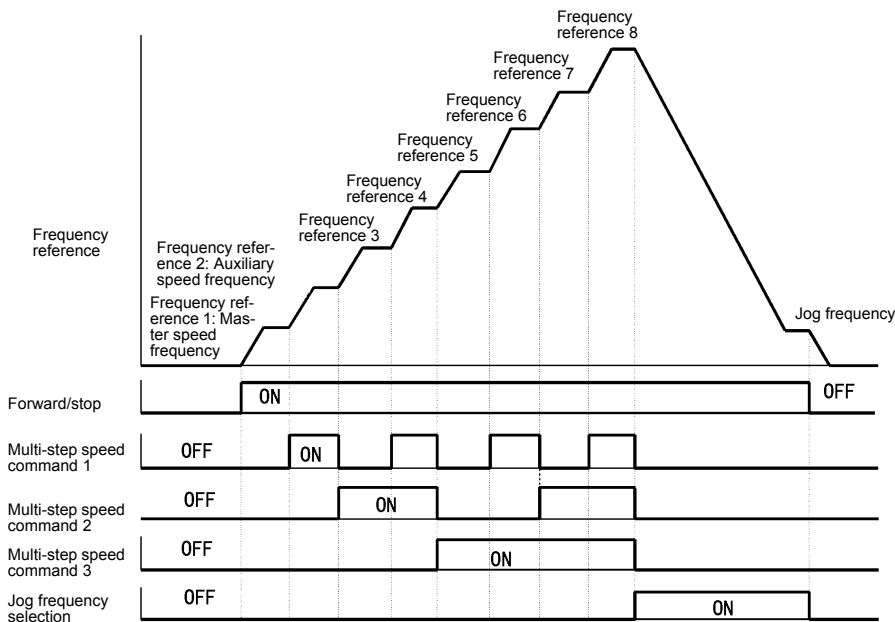

Fig 6.11 Multi-step speed command/Jog Frequency Selection Time Chart

Note:

- The multifunction input setting “Multistep Speed Reference 4” (32) has to be used for selecting the frequency references from d1-09 to d1-16.
- The multifunction input setting “Jog Frequency 2” (69) can be used for jog frequency selection when a 3-wire control is used for the control circuit. If it is selected while the inverter is initialized to 2-wire control an OPE03 error will be displayed.

Run Command Input Methods

◆ Selecting the Run Command Source

Set parameter b1-02 to select the source for the run command.

■ Related Parameters

Parameter No.	Name	Factory Setting	Change during Operation	Control Methods			
				V/f	V/f with PG	Open Loop Vector	Closed Loop Vector
b1-02	RUN command source selection	1	No	Q	Q	Q	Q

■ Performing Operations Using the Digital Operator

When b1-02 is set to 0, you can perform Inverter operations using the Digital Operator keys (RUN, STOP, and FWD/REV). For details on the Digital Operator, refer to [page 3-1, Digital Operator and Modes](#).

■ Performing Operations Using Control Circuit Terminals

When b1-02 is set to 1, you can perform Inverter operations using the control circuit terminals.

Performing Operations Using a 2-wire Control

The factory setting is set to a 2-wire control. When the control circuit terminal S1 is set to ON, forward operation will be performed, and when S1 is turned OFF, the Inverter will stop. In the same way, when the control circuit terminal S2 is set to ON, reverse operation will be performed, and when S2 is turned OFF, the Inverter will stop.

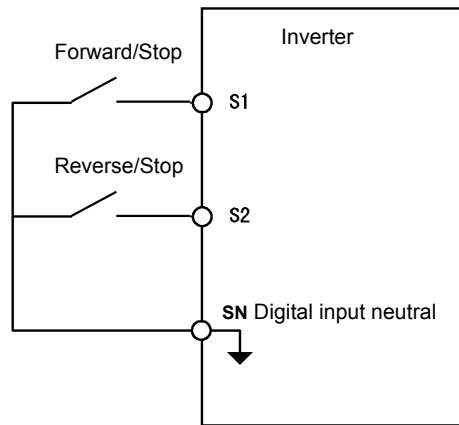

Fig 6.12 2-Wire Control Wiring Example with Positive Logic

Performing Operations Using 3-Wire Control

If one of the parameter H1-01 to H1-05 (digital input terminals S3 to S7) is set to 0, the terminals S1 and S2 are used for a 3-wire control, and the multi-function input terminal that has been set to 0 works as a forward/reverse selection command terminal.

When the Inverter is initialized for 3-wire control with A1-03, multi-function input 3 becomes the input terminal for the forward/reverse run command.

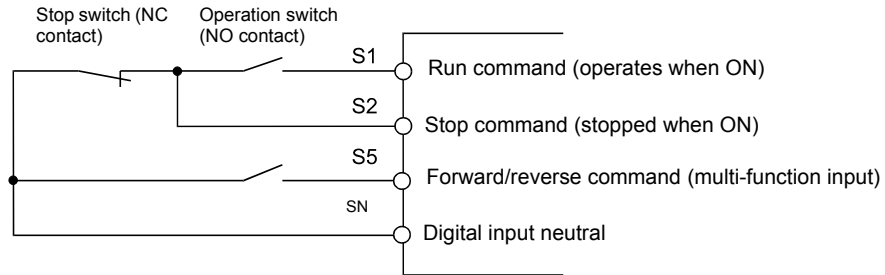

Fig 6.13 3-Wire Control Wiring Example

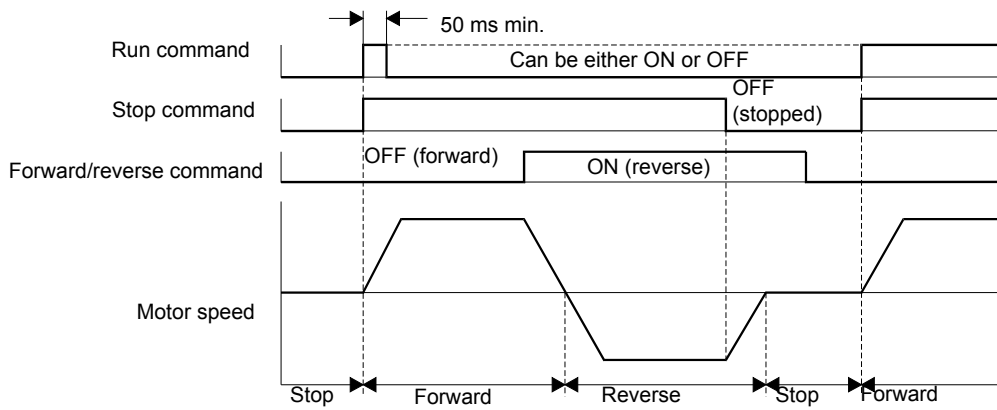

Fig 6.14 Three-wire Control Timing Chart



INFO

Use a control circuit that turns ON terminal S1 for 50 ms or longer for the run command. This will make the run command self-holding in the Inverter.

Stopping Methods

◆ Selecting the Stopping Method when a Stop Command is Input

There are four methods of stopping the Inverter when a stop command is input:

- Deceleration to stop
- Coast to stop
- DC braking stop
- Coast to stop with timer

Set parameter b1-03 to select the Inverter stopping method. DC injection braking to stop (b1-03=2) and coast to stop with a timer (b1-03=3) can not be set for Closed Loop Vector control.

■ Related Parameters

Parameter No.	Name	Factory Setting	Change during Operation	Control Methods			
				V/f	V/fwith PG	Open Loop Vector	Closed Loop Vector
b1-03	Stopping method selection	0	No	Q	Q	Q	Q
b1-05	Zero speed operation selection	0	No	No	No	No	A
b2-01	Zero speed level	0.5 Hz	No	A	A	A	A
b2-02	DC injection braking current	50%	No	A	A	A	No
b2-04	DC injection braking time at stop	0.50 s	No	A	A	A	A

■ Deceleration to Stop (b1-03=0)

If the stop command is input (i.e., the run command is turned OFF) when b1-03 is set to 0, the motor decelerates to stop according to the deceleration time that has been set. (Default: C1-02 (Deceleration Time 1))

If the output frequency when decelerating to stop falls below b2-01, the DC injection brake will be applied using the DC current set in b2-02 for the time set in b2-04.

For deceleration time settings, refer to [page 6-19, Setting Acceleration and Deceleration Times](#).

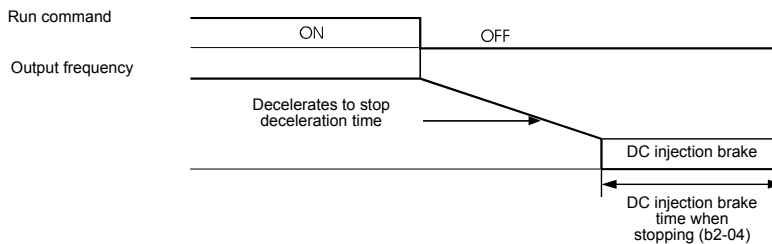

Fig 6.15 Deceleration to Stop

When Closed Loop Vector control is selected, the stopping behavior depends on the setting of b1-05.

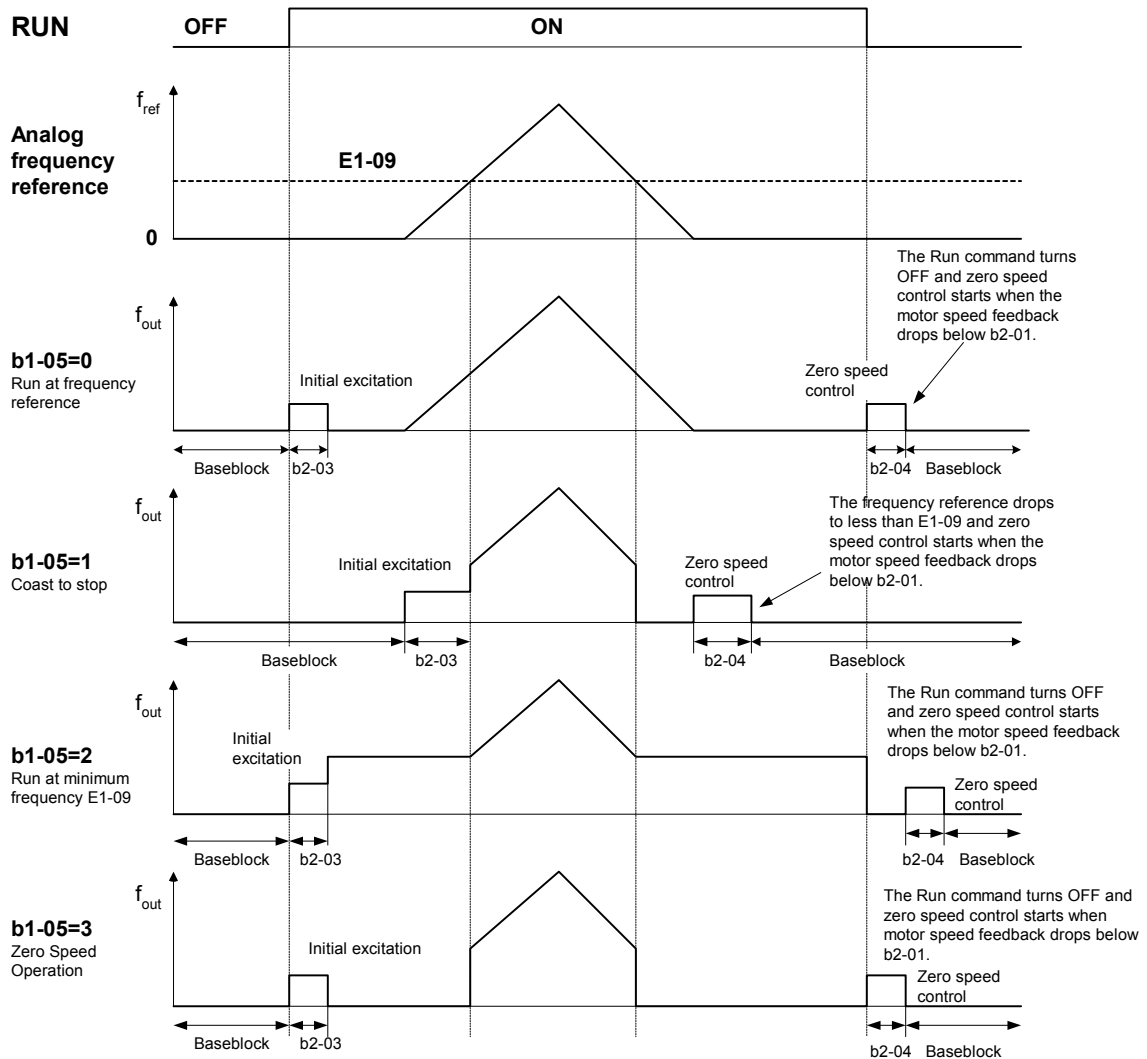

Fig 6.16 Deceleration to Stop in Closed Loop Vector Control

Coast to Stop (b1-03=1)

When b1-03 is set to 1 and the Run command is turned off, the inverter output will be interrupted immediately and the motor will coast to stop. The time until the motor stands depends on the inertia and load situation.

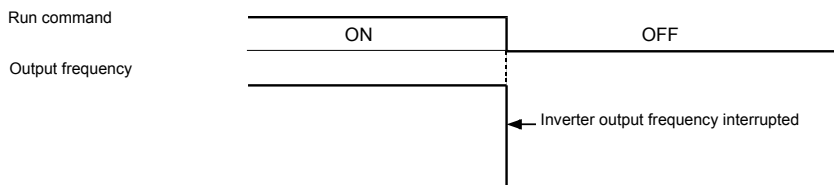

Fig 6.17 Coast to Stop



INFO

After the stop command is input, Run commands are ignored until the Minimum Baseblock Time (L2-03) has elapsed.

■DC Braking to Stop (b1-03=2)

After the stop command has been input and the minimum baseblock time (L2-03) has elapsed, DC injection will be applied to the motor. The applied DC injection current can be set in parameter b2-02. The DC injection braking time depends on the set value of b2-04 and on the output frequency at the moment when the stop command is input and. If the output frequency was higher than 10% of the maximum output frequency (E1-04) the DC injection time is lengthened like shown in the figure below.

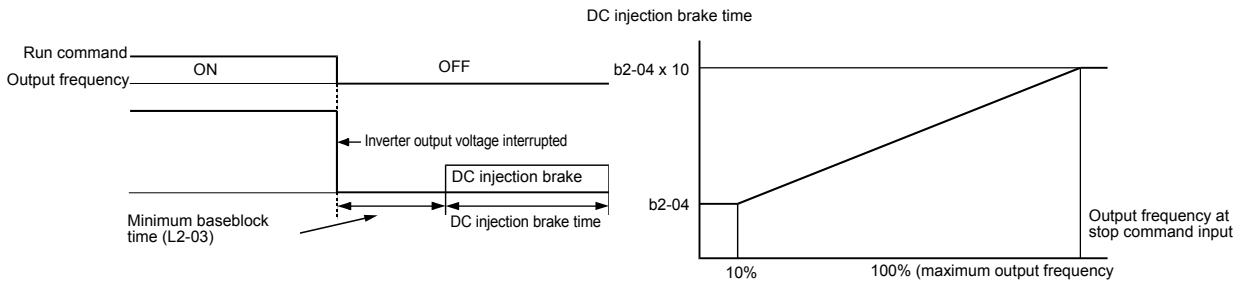

Fig 6.18 DC Injection Braking to Stop



INFO

Lengthen the Minimum Baseblock Time (L2-03) when an overcurrent (OC) occurs during stopping.

■Coast to Stop with a Timer (b1-03=3)

If the stop command is input (i.e., the run command is turned OFF) when b1-03 is set to 3, the Inverter output is switched off so that the motor coasts to stop. After the stop command is input, run commands are ignored until the time T has elapsed. The time T depends on the output frequency when the stop command is input and on the deceleration time.

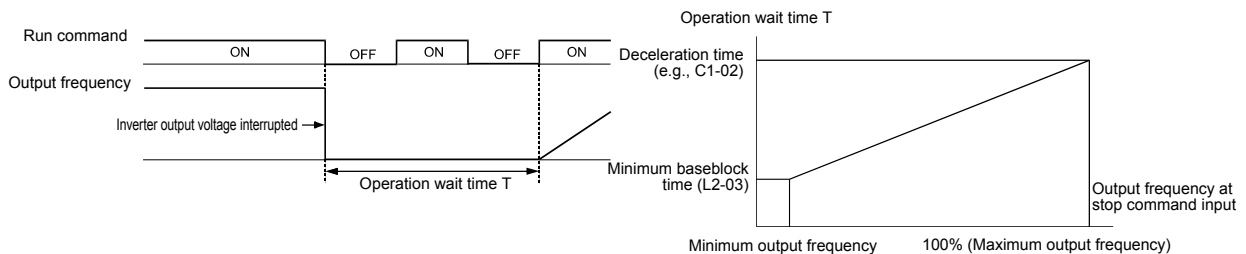

Fig 6.19 Coast to Stop with Timer

◆ Using the DC Injection Brake

The DC injection brake can be used to stop a coasting motor before restarting it or to hold it at the deceleration end when the inertia is large. Set parameter b2-03 to apply DC injection to the motor, before it starts to accelerate. Set parameter b2-04 to apply a DC injection brake to the motor at stopping.

Setting b2-03/04 to 0 to disables the DC injection brake at start/stop.

Set the DC injection brake current using b2-02.

■ Related Parameters

Parameter No.	Name	Factory Setting	Change during Operation	Control Methods			
				V/f	V/f with PG	Open Loop Vector	Closed Loop Vector
b2-01	Zero speed level (DC injection braking starting frequency)	0.5 Hz	No	A	A	A	A
b2-02	DC injection braking current	50%	No	A	A	A	No
b2-03	DC injection braking time at start	0.00 s	No	A	A	A	A
b2-04	DC injection braking time at stop	0.50 s	No	A	A	A	A

Multi-function Digital Inputs (H1-01 to H1-05)

Set Value	Function	Control Methods			
		V/f	V/f with PG	Open Loop Vector	Closed Loop Vector
60	DC injection brake command	Yes	Yes	Yes	Yes

■ Inputting the DC Injection Brake Command from Control Circuit Terminals

If you set a digital input terminal (H1-□□) to 60 (DC injection brake command), the DC brake can be applied by enabling or disabling this input. The time chart for the DC injection brake is shown below.

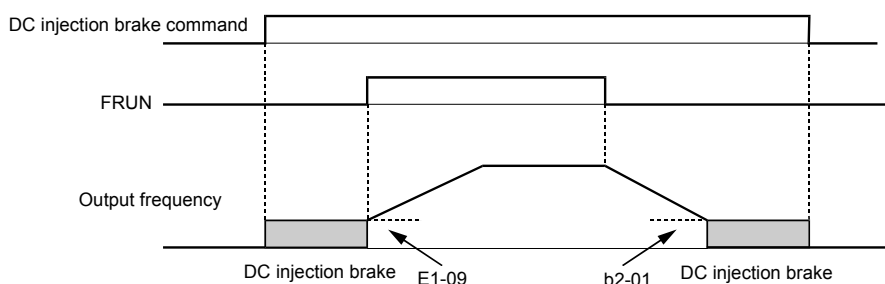

If you input the DC injection brake command from an external terminal, and if a run command or jog command is input, the DC injection brake will be disabled, and operation will resume.

Fig 6.20 DC Injection Brake Time Chart

■ Changing the DC Injection Brake Current Using an Analog Input

If you set H3-09 (Analog Input Terminal A2 Function Selection) to 6 (DC injection brake current), you can change the DC injection brake current level using the analog input.

At 10 V input (voltage) or 20 mA input (current), 100% of the Inverter rated current will be applied.

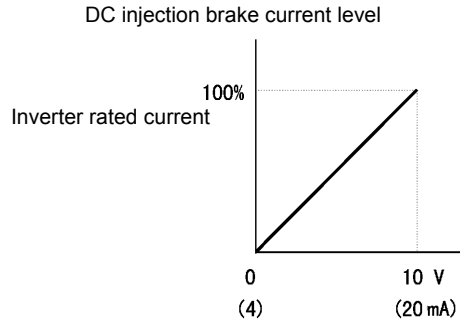

Fig 6.21 DC Injection Brake Current Using an Analog Input

◆ Using an Emergency Stop

Set a digital input terminal (H1-□□) to 15 or 17 (emergency stop) to decelerate to stop using the emergency stop deceleration time set in C1-09. If inputting the emergency stop with an NO contact, set the multi-function input terminal (H1-□□) to 15, and if inputting the emergency stop with an NC contact, set the multi-function input terminal (H1-□□) to 17.

After the emergency stop command has been input, operation cannot be restarted until the Inverter has stopped. To cancel the emergency stop, turn OFF the run command and emergency stop command.

■ Related parameters

Parameter No.	Name	Factory Setting	Change during Operation	Control Methods			
				V/f	V/f with PG	Open Loop Vector	Closed Loop Vector
C1-09	Emergency stop time	10.0 s	No	A	A	A	A

Multi-function Digital Inputs (H1-01 to H1-05)

Set Value	Function	Control Methods			
		V/f	V/f with PG	Open Loop Vector	Closed Loop Vector
15	Emergency Stop, NO contact	Yes	Yes	Yes	Yes
17	Emergency Stop, NC contact	Yes	Yes	Yes	Yes

Acceleration and Deceleration Characteristics

◆ Setting Acceleration and Deceleration Times

The acceleration time indicates the time to increase the output frequency from 0% to 100% of the maximum output frequency (E1-04). The deceleration time indicates the time to decrease the output frequency from 100% to 0% of (E1-04). The accel./decel. times 1 are used with the factory setting, the accel./decel. times 2 to 4 can be selected using a multifunction digital input.

■ Related Parameters

Parameter No.	Name	Factory Setting	Change during Operation	Control Methods			
				V/f	V/f with PG	Open Loop Vector	Closed Loop Vector
C1-01	Acceleration time 1	10.0 s	Yes	Q	Q	Q	Q
C1-02	Deceleration time 1		Yes	Q	Q	Q	Q
C1-03	Acceleration time 2		Yes	A	A	A	A
C1-04	Deceleration time 2		Yes	A	A	A	A
C1-05	Acceleration time 3		No	A	A	A	A
C1-06	Deceleration time 3		No	A	A	A	A
C1-07	Acceleration time 4		No	A	A	A	A
C1-08	Deceleration time 4		No	A	A	A	A
C1-10	Acceleration/deceleration time setting unit	1	No	A	A	A	A
C1-11	Acceleration/deceleration time switching frequency	0.0 Hz	No	A	A	A	A
C2-01	S-curve characteristic time at acceleration start	0.20 s	No	A	A	A	A
C2-02	S-curve characteristic time at acceleration end	0.20 s	No	A	A	A	A
C2-03	S-curve characteristic time at deceleration start	0.20 s	No	A	A	A	A
C2-04	S-curve characteristic time at deceleration end	0.00 s	No	A	A	A	A

Multi-function Digital Inputs (H1-01 to H1-05)

Set Value	Function	Control Methods			
		V/f	V/f with PG	Open Loop Vector	Closed Loop Vector
7	Acceleration/Deceleration time 1	Yes	Yes	Yes	Yes
1A	Acceleration/Deceleration time 2	Yes	Yes	Yes	Yes

■ Setting Acceleration and Deceleration Time Units

Set the acceleration/deceleration time units using C1-10. The factory setting is 1.

Set value	Details
0	The acceleration/deceleration time setting range is 0.00 to 600.00 in units of 0.01 s.
1	The acceleration/deceleration time setting range is 0.00 to 6000.0 in units of 0.1 s.

■ Switching Acceleration and Deceleration Time Using Multi-Function Input Terminal Commands

Four different acceleration times and deceleration times can be set. When the multi-function input terminals (H1-□□) are set to 7 (acceleration/deceleration time selection 1) and 1A (acceleration/deceleration time selection 2), you can switch the acceleration/deceleration time even during operation by combining the ON/OFF status of the terminals.

The following table shows the acceleration/deceleration time switching combinations.

Acceleration/Deceleration Time Selection 1 Terminal	Acceleration/Deceleration Time Selection 2 Terminal	Acceleration Time	Deceleration Time
OFF	OFF	C1-01	C1-02
ON	OFF	C1-03	C1-04
OFF	ON	C1-05	C1-06
ON	ON	C1-07	C1-08

■ Switching Acceleration and Deceleration Times Using a Frequency Level

The acceleration/deceleration times can be switched over automatically at a certain output frequency which can be set in parameter C1-11.

Fig 6.22 shows the working principle of the function.

Set C1-11 to a value other than 0.0 Hz. If C1-11 is set to 0.0 Hz, the function will be disabled.

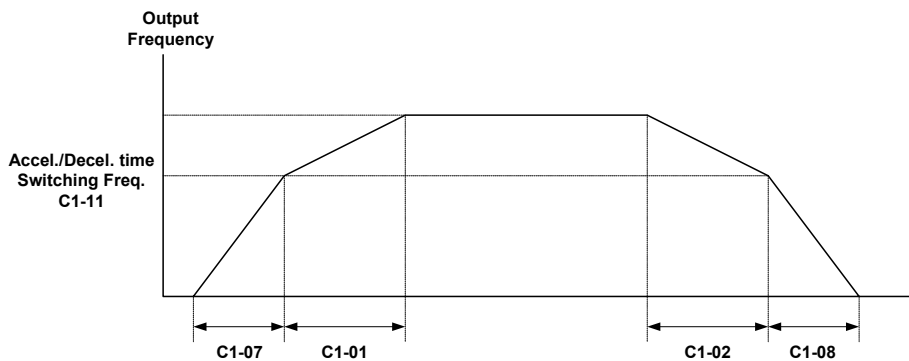

When output frequency \geq C1-11, acceleration and deceleration are performed using Acceleration/deceleration Time 1 (C1-01, C1-02).

When output frequency $<$ C1-11, acceleration and deceleration are performed using Acceleration/deceleration Time 4 (C1-07, C1-08).

Fig 6.22 Acceleration/deceleration Time Switching Frequency

■ Adjusting Acceleration and Deceleration Time Using an Analog Input

If you set H3-09 (Analog Input Terminal A2 Function Selection) to 5 (acceleration/deceleration time gain), you can adjust the acceleration/deceleration time using terminal A2's input voltage.

The resulting acceleration time is as follows:

Acceleration time = C1-01 set value x acceleration/deceleration time gain

Acceleration/deceleration time gain

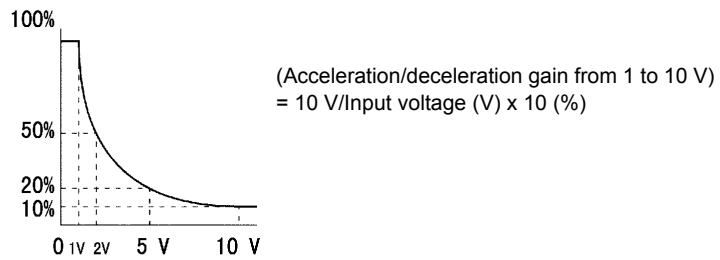

Fig 6.23 Acceleration/Deceleration Time Gain Using an Analog Input

■ Entering S-curve Characteristics in the Acceleration and Deceleration Time

By performing acceleration and deceleration using an S-curve pattern, you can reduce shock when starting and stopping the machine.

Four different S-curve characteristic times can be set: At acceleration start, at deceleration start, at acceleration end and at deceleration end.



INFO

When S-curve is set, calculate acceleration/deceleration time as follows:

$$\text{Accel. Time} = \frac{C2-01 + C2-02}{2} + C1-01/03/05/07$$

$$\text{Decel. Time} = \frac{C2-03 + C2-04}{2} + C1-02/04/06/08$$

Setting Example

The S-curve characteristic when switching operation (forward/reverse) is shown in the following diagram.

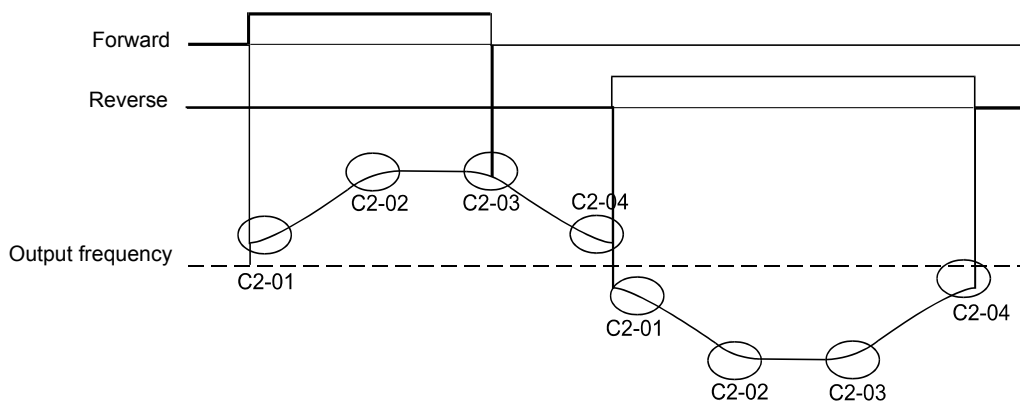

Fig 6.24 S-curve Characteristic during Operation Switching

◆ Accelerating and Decelerating Heavy Loads (Dwell Function)

The dwell function holds the output frequency temporarily when starting or stopping heavy loads. When using the dwell function, deceleration to stop must be set as stopping method (b1-03 = 0).

■ Related Parameters

Parameter No.	Name	Factory Setting	Change during Operation	Control Methods			
				V/f	V/f with PG	Open Loop Vector	Closed Loop Vector
b6-01	Dwell frequency at start	0.0 Hz	No	A	A	A	A
b6-02	Dwell time at start	0.0 s	No	A	A	A	A
b6-03	Dwell frequency at stop	0.0 Hz	No	A	A	A	A
b6-04	Dwell time at stop	0.0 s	No	A <td A	A	A	

■ Applying an Output Frequency Dwell

An output frequency dwell can be applied to prevent a stalling of the motor at start if the static friction and the inertia are large or to prevent a coasting of the motor at stop. The frequency level at which the dwell function starts can be set separately for the start and the stop in the parameters b6-01 and b6-03. The times can be set in the parameters b6-02 and b6-04 (refer to [Fig 6.25](#))

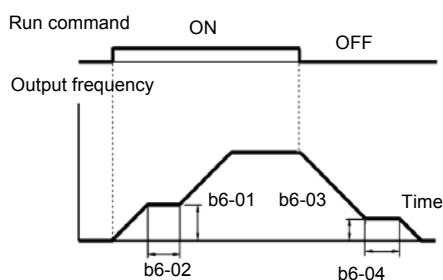

Fig 6.25 Output Frequency Dwell Settings

◆ Preventing the Motor from Stalling During Acceleration (Stall Prevention During Acceleration Function)

The Stall Prevention During Acceleration function prevents the motor from stalling if a heavy load is applied to the motor, or sudden rapid acceleration is performed.

If L3-01 is set to 1 (enabled) and the Inverter output current reaches 85 % of the set value in L3-02, the acceleration rate will begin to slow down. When L3-02 is exceeded, the acceleration will stop.

If L3-01 is set to 2 (optimum adjustment), the motor accelerates so that the current is held at the level set in L3-03. With this setting, the acceleration time setting is ignored.

■ Related Parameters

Parameter No.	Name	Factory Setting	Change during Operation	Control Methods			
				V/f	V/f with PG	Open Loop Vector	Closed Loop Vector
L3-01	Stall prevention selection during acceleration	1	No	A	A	A	No
L3-02	Stall prevention level during acceleration	150%*	No	A	A	A	No
L3-03	Stall prevention limit during acceleration	50%	No	A	A	A	No

* Shows the initial value when C6-01 is set to 0 (default). If C6-01 is set to 1 or 2, the initial value is 120%.

■Time Chart

The following figure shows the frequency characteristics when L3-01 is set to 1.

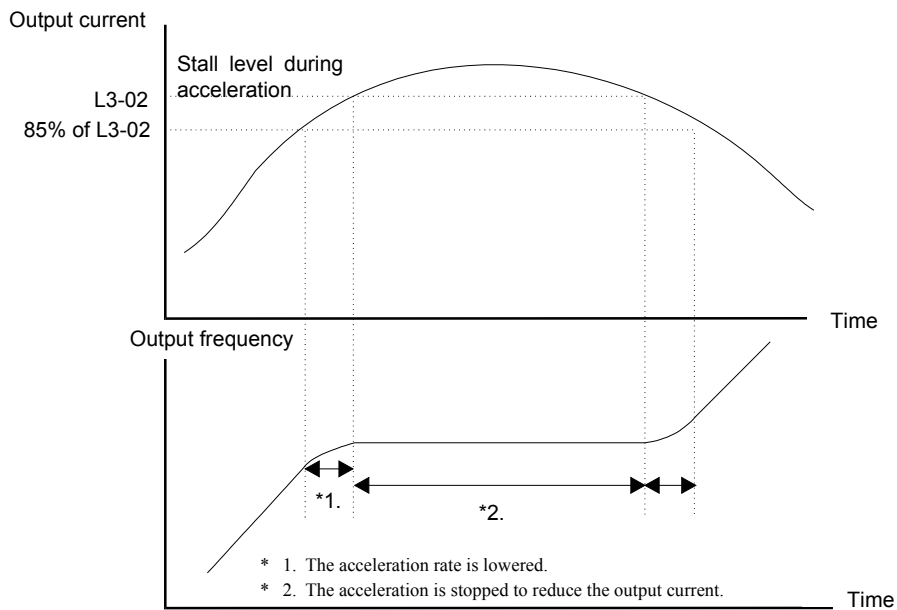

Fig 6.26 Time Chart for Stall Prevention During Acceleration

■Setting Precautions

- If the motor capacity is small compared to the Inverter capacity or if the inverter is operated using the factory settings and the motor stalls, lower the set value of L3-02.
- If using the motor in the constant power range, L3-02 will be automatically lowered to prevent stalling. L3-03 is the limit value to prevent the stall prevention level in the constant power range from being reduced more than necessary (see [Fig 6.27](#)).
- Set the parameters as a percentage taking the inverter rated current to be 100%.

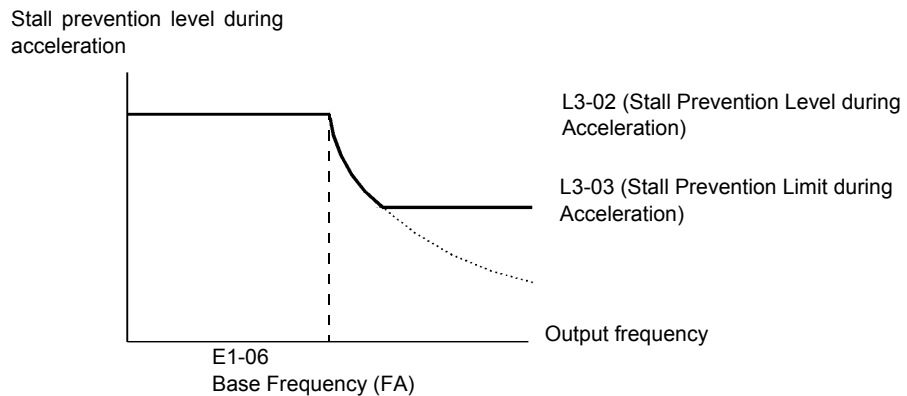

Fig 6.27 Stall Prevention Level and Limit During Acceleration

◆ Preventing Overvoltage During Deceleration

The stall prevention during deceleration function lengthens the deceleration time automatically with respect to the DC-bus voltage to avoid overvoltage tripping.

■ Related Parameters

Parameter No.	Name	Factory Setting	Change during Operation	Control Methods			
				V/f	V/fwith PG	Open Loop Vector	Closed Loop Vector
L3-04	Stall prevention selection during deceleration function selection	1	No	A	A	A	A

■ Setting the Stall Prevention Selection During Deceleration (L3-04)

There are four different settings selectable for L3-04.

L3-04=0: Disabled

This setting disables the stall prevention function during deceleration. The motor will be decelerated using the time set in C1-02 (C1-04/06/08). If the load inertia is very high and an OV fault occurs during deceleration a Braking option has to be used or the time has to be lengthened.

L3-04=1: Enabled

This setting enables the stall prevention during deceleration. The inverter tries to decelerate within the set deceleration time. It also observes the DC bus voltage. If the DC bus voltage reaches the stall prevention level the deceleration is stopped and the output frequency is held. When the DC bus voltage falls below the stall prevention level the deceleration will be continued.

L3-04=2: Intelligent deceleration

This setting enables the stall prevention during deceleration. The deceleration time set as C1-□□ is taken as reference. The function automatically tries to optimize the deceleration time by observing the DC bus voltage and shortening the deceleration time. The function does not lengthen the deceleration time, i.e. if C1-□□ is set too short OV may occur.

L3-04=3: Enabled with braking resistor

This setting enables the stall prevention during deceleration using a braking option. It works similar to setting 2, the only difference is that a braking option is used. The deceleration time set in C1-□□ is also disregarded.

■Setting Example

An example of stall prevention during deceleration when L3-04 is set to 1 is shown below.

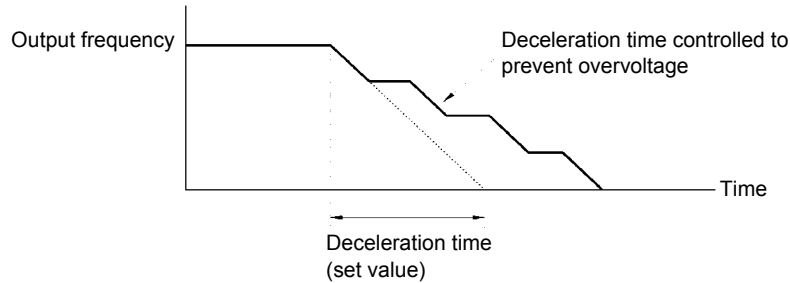

Fig 6.28 Stall Prevention During Deceleration Operation

■Setting Precautions

- The stall prevention level during deceleration differs depending on the inverter rated voltage and input voltage. Refer to the following table for details.

Inverter Rated/Input Voltage		Stall Prevention Level during Deceleration (V)
200 V class		380
400 V class	E1-01 \geq 400 V	760
	E1-01 $<$ 400 V	660

- When using the braking option (braking resistor, braking resistor units, and braking units), be sure to set parameter L3-04 to 0 or 3.
- When a braking option is used and the deceleration time shall be optimized (shorter than setting of C1-02/04/06/08), L3-04 has to be set to 3.

Adjusting Frequency References

◆ Adjusting Analog Frequency References

The analog reference values can be adjusted using the gain and bias functions for the analog inputs.

■ Related Parameters

Parameter No.	Name	Factory Setting	Change during Operation	Control Methods			
				V/f	V/f with PG	Open Loop Vector	Closed Loop Vector
H3-01	Multi-function analog input terminal A1 signal level selection	0	No	A	A	A	A
H3-02	Frequency reference terminal A1 input gain	100.0%	Yes	A	A	A	A
H3-03	Frequency reference terminal A1 input bias	0.0%	Yes	A	A	A	A
H3-08	Multi-function analog A2 signal level selection	2	No	A	A	A	A
H3-09	Multi-function analog A2 function selection	0	No	A	A	A	A
H3-10	Multi-function analog A2 input gain	100.0%	Yes	A	A	A	A
H3-11	Multi-function analog A2 input bias	0.0%	Yes	A	A	A	A
H3-12	Analog input filter time constant	0.03 s	No	A	A	A	A
H3-13	Terminal A1/A2 switching	0	No	A	A	A	A

■ Adjusting Analog Frequency Reference Using Parameters

The frequency reference can be input from the control circuit terminals using analog voltage or current signals (analog input A2 only).

The input signal levels can be selected using

- H3-01 for the analog input A1
- H3-08 for the analog input A2

Adjustments to the signals can be made using:

- H3-02 (Gain) and H3-03 (Bias) if analog input A1 is selected to be the frequency reference input
- H3-10 (Gain) and H3-11 (Bias) if analog input A2 is selected to be the frequency reference input

Refer to [Fig 6.29](#) for adjusting the signal using the gain and bias functions.

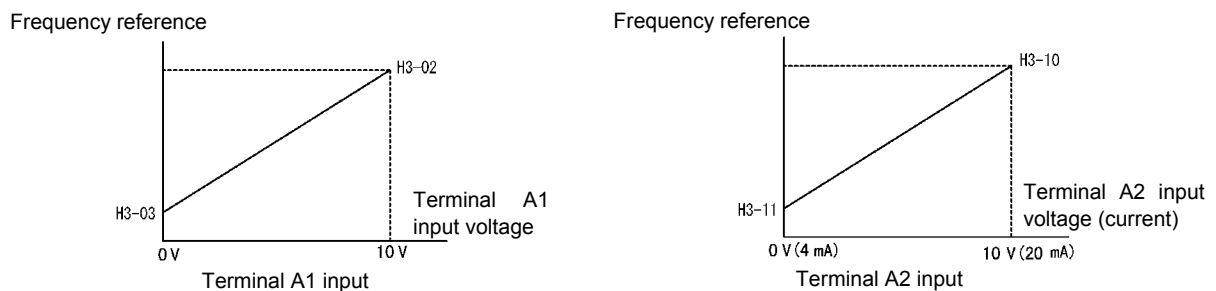

Fig 6.29 Terminals A1 and A2 Inputs

■ Adjusting Frequency Gain Using an Analog Input

When H3-09 is set to 1 (frequency gain), the frequency gain can be adjusted using analog input A2.

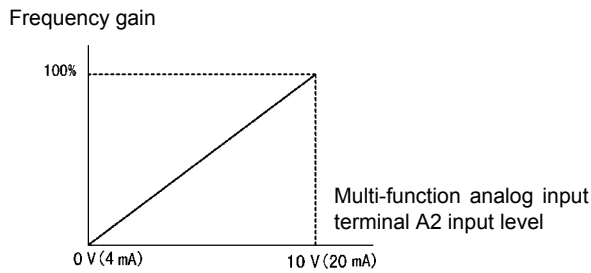

Fig 6.30 Frequency Gain Adjustment (Terminal A2 Input)

The frequency gain for terminal A1 is the product of H3-02 and gain which is input at terminal A2. For example, when H3-02 is set to 100% and the terminal A2 input is 5 V, the frequency reference gain will be 50%.

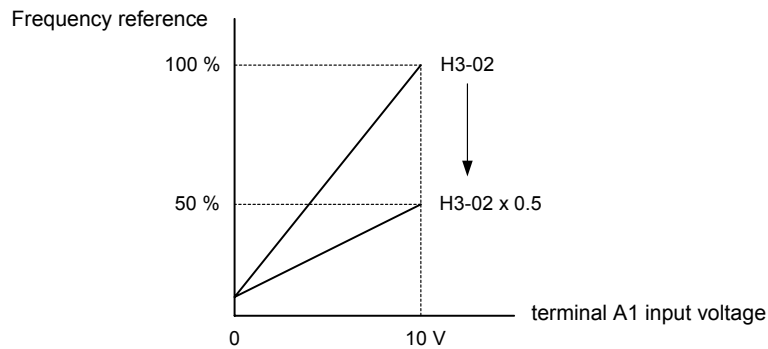

Fig 6.31 Frequency Gain Setting Example

■ Adjusting Frequency Bias Using an Analog Input

When parameter H3-09 is set to 0 (Frequency Bias), the frequency equivalent to the terminal A2 input voltage is added to A1 as a bias.

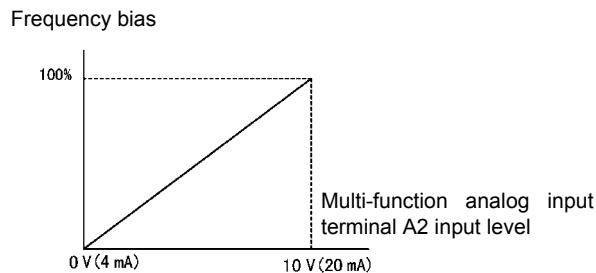

Fig 6.32 Frequency Bias Adjustment (Terminal A2 Input)

For example, if H3-02 is 100%, H3-03 is 0%, and the terminal A2 input is 1 V, the frequency reference when 0 V is input to A1 will be 10% of the maximum output frequency (E1-04).

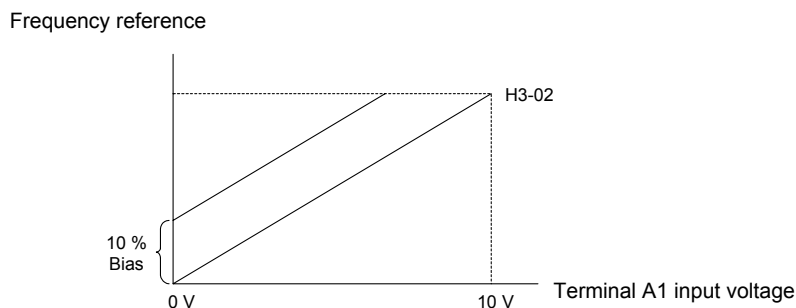

Fig 6.33 Frequency Bias Setting Example

◆ Operation Avoiding Resonance (Jump Frequency Function)

The jump frequency function allows the prohibition or “jumping” of certain frequencies within the Inverter’s output frequency range so that the machine can operate without oscillations caused by resonant frequencies of the machine.

It can also be used for deadband control.

During acceleration and deceleration the output frequency goes linear through the prohibited frequency ranges, i.e. no output frequency jumps are performed

During constant speed operation an operation within the jump frequency range is prohibited.

■ Related Parameters

Parameter No.	Name	Factory Setting	Change during Operation	Control Methods			
				V/f	V/fwith PG	Open Loop Vector	Closed Loop Vector
d3-01	Jump frequency 1	0.0 Hz	No	A	A	A	A
d3-02	Jump frequency 2	0.0 Hz	No	A	A	A	A
d3-03	Jump frequency 3	0.0 Hz	No	A	A	A	A
d3-04	Jump frequency width	1.0 Hz	No	A	A	A	A

The relationship between the output frequency and the jump frequency reference is shown in [Fig 6.34](#).

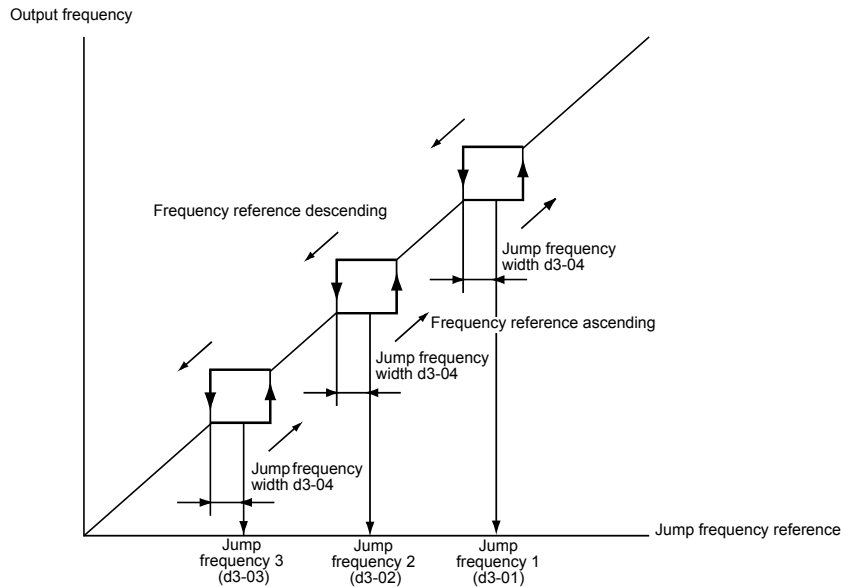

Fig 6.34 Jump Frequency

■Setting Jump Frequency Reference Using an Analog Input

When parameter H3-09 (analog input A2 function selection) is set to A (jump frequency), the jump frequency can be changed by the terminal A2 input value.

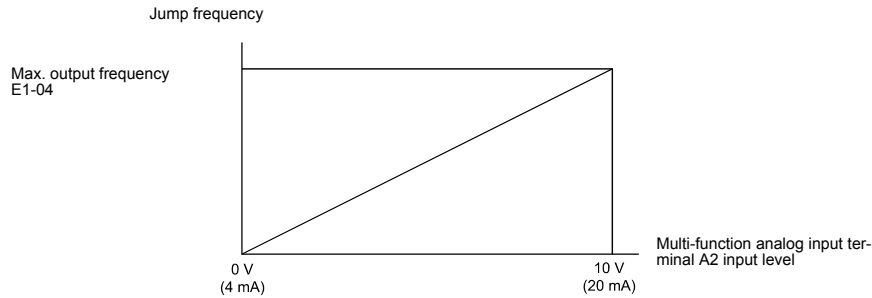

Fig 6.35 Jump Frequency Setting Using an Analog Input

■Setting Precautions

- Set the jump frequencies according to the following formula: $d3-01 \geq d3-02 \geq d3-03 > \text{Analog input}$.
- When parameters d3-01 to d3-03 are set to 0 Hz, the jump frequency function is disabled.

■Adjusting Pulse Train Input Reference Values

If b1-01 is set to 4 and H6-01 is set to 0, the pulse train input is selected as the frequency reference source. Set the pulse frequency that is equal to 100% reference in parameter H6-02, and then adjust the gain and bias accordingly using H6-03 and H6-04.

■Related Parameters

Parameter No.	Name	Factory Setting	Change during Operation	Control Methods			
				V/f	V/f with PG	Open Loop Vector	Closed Loop Vector
H6-01	Pulse train input function selection	0	No	A	A	A	A
H6-02	Pulse train input scaling	1440 Hz	Yes	A	A	A	A
H6-03	Pulse train input gain	100.0%	Yes	A	A	A	A
H6-04	Pulse train input bias	0.0%	Yes	A	A	A	A
H6-05	Pulse train input filter time	0.10 s	Yes	A	A	A	A

The block diagram in Fig 6.36 explains the functioning of the pulse train input.

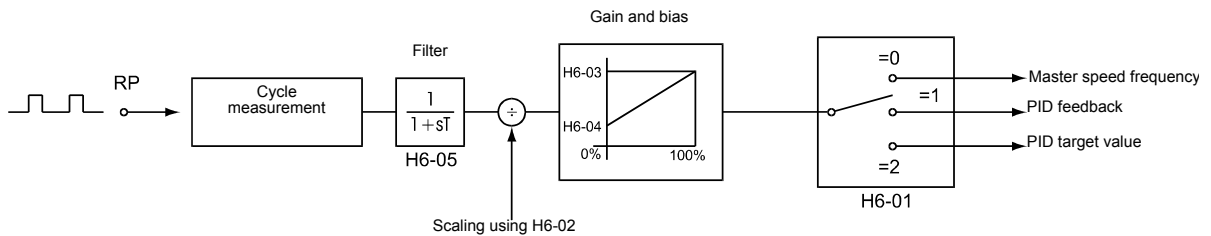

Fig 6.36 Frequency Reference Adjustments Using Pulse Train Inputs

The principle for setting the input gain and bias is the same as for the analog inputs (refer page 6-26 pp). The only difference is that the input signal is not a voltage or a current but a pulse train.

Speed Limit (Frequency Reference Limits)

◆ Limiting the Maximum Output Frequency

If the motor is not allowed to rotate above a certain frequency, use parameter d2-01 to set a frequency reference upper limit.

The limit value is set as a percentage, taking E1-04 (Maximum Output Frequency) to be 100%.

■ Related Parameters

Parameter No.	Name	Factory Setting	Change during Operation	Control Methods			
				V/f	V/f with PG	Open Loop Vector	Closed Loop Vector
d2-01	Frequency reference upper limit	100.0%	No	A	A	A	A

◆ Limiting the Minimum Output Frequency

If the motor is not allowed to rotate below a certain frequency, use parameters d2-02 or d2-03 to set a frequency reference lower limit.

There are two methods of limiting the minimum frequency, as follows:

- Set d2-02 to adjust the minimum level for all frequencies.
- Set d2-03 to adjust the minimum level for the master speed frequency (i.e., the lower level is not valid for the jog frequency, multi-step speed frequency, and auxiliary frequency).

■ Related Parameters

Parameter No.	Name	Factory Setting	Change during Operation	Control Methods			
				V/f	V/f with PG	Open Loop Vector	Closed Loop Vector
d2-02	Frequency reference lower limit	0.0%	No	A	A	A	A
d2-03	Master speed reference lower limit	0.0%	No	A	A	A	A

■ Adjusting Frequency Lower Limit Using an Analog Input

If parameter H3-09 (analog input A2 function selection) is set to 9 (output frequency lower level), the frequency lower level can be adjusted using the terminal A2 input level (see [Fig 6.37](#)).

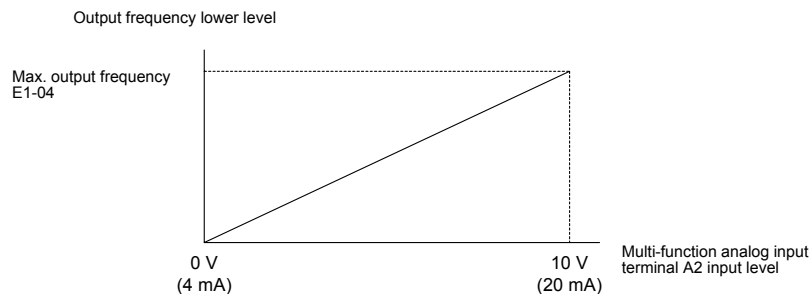

Fig 6.37 Analog Input A2 Characteristics for Frequency Reference Lower Limit

If parameter d2-02 and terminal A2 output frequency lower level have been set at the same time, the larger set value will become the frequency lower limit.

Frequency Detection

◆ Speed Agreement Function

There are eight different types of frequency detection methods available. The digital multifunction outputs M1 to M6 can be programmed for this function and can be used to indicate a frequency detection or agreement to any external equipment.

■ Related Parameters

Parameter No.	Name	Factory Setting	Change during Operation	Control Methods			
				V/f	V/f with PG	Open Loop Vector	Closed Loop Vector
L4-01	Speed agreement detection level	0.0 Hz	No	A	A	A	A
L4-02	Speed agreement detection width	2.0 Hz	No	A	A	A	A
L4-03	Speed agreement detection level (\pm)	0.0 Hz	No	A	A	A	A
L4-04	Speed agreement detection width (\pm)	2.0 Hz	No	A	A	A	A

■ Multifunction Output Settings: H2-01 to H2-03 (M1 – M6 function selection)

The table below shows the necessary H2-01 to H2-03 parameter setting for each of the speed agreement functions. Refer to the timing charts on the following page for details.

Function	Setting
$f_{ref} = f_{out}$ Agree 1	2
$f_{out} = f_{set}$ Agree 1	3
Frequency detection 1	4
Frequency detection 2	5
$f_{ref} = f_{out}$ Agree 2	13
$f_{out} = f_{set}$ Agree 2	14
Frequency detection 3	15
Frequency detection 4	16

■ Setting Precautions

- With L4-01 an absolute speed agreement level is set, i.e. a speed agreement is detected in both directions (FWD and REV).
- With L4-03 a signed speed agreement level is set, i.e. a speed agreement is detected only in the set direction (positive level → FWD direction, negative level → REV direction).

Time Charts

The following table shows the time charts for each of the speed agreement functions.

Related parameter	L4-01: Speed Agree Level L4-02: Speed Agree Width	L4-03: Speed Agree Level +/- L4-04: Speed Agree Width
$f_{ref} = f_{out}$ Agree	<p>$f_{ref} = f_{out}$ Agree 1</p> <p>$f_{ref} = f_{out}$ Agree OFF ON</p> <p>(Multi-function output setting = 2)</p>	<p>$f_{ref} = f_{out}$ Agree 2</p> <p>$f_{ref} = f_{out}$ Agree 2 OFF ON</p> <p>(Multi-function output setting = 13)</p>
$f_{out} = f_{set}$ Agree	<p>$f_{out} = f_{set}$ Agree 1 (ON at the following conditions during frequency agree)</p> <p>$f_{out} = f_{set}$ Agree 1 ON OFF</p> <p>(Multi-function output setting = 3)</p>	<p>$f_{out} = f_{set}$ Agree 2 (ON at the following conditions during frequency agree)</p> <p>$f_{out} = f_{set}$ Agree 2 ON OFF</p> <p>(Multi-function output setting = 14)</p>
Frequency Detection	<p>Frequency (FOUT) Detection 1 (L4-01 > Output frequency)</p> <p>Freq. Detection 1 ON OFF</p> <p>(Multi-function output setting = 4)</p>	<p>Frequency (FOUT) Detection 3 (L4-03 > Output frequency)</p> <p>Freq. Detection 3 ON OFF</p> <p>(Multi-function output setting = 15)</p>
	<p>Frequency (FOUT) Detection 2 (L4-01 < Output frequency)</p> <p>Freq. Detection 2 OFF ON</p> <p>(Multi-function output setting = 5)</p>	<p>Frequency Detection 4 (L4-03 < Output frequency)</p> <p>Freq. Detection 4 OFF ON</p> <p>(Multi-function output setting = 16)</p>

Improving the Operation Performance

◆ Reducing the Motor Speed Fluctuation (Slip Compensation Function)

When the load is large, the motor slip also grows and the motor speed decreases. The slip compensation function keeps the motor speed constant, regardless of changes in load. When the motor is operating at the rated load, parameter E2-02 (Motor Rated Slip) × the slip compensation gain value in parameter C3-01 is added to the output frequency.

■ Related Parameters

Parameter No.	Name	Factory Setting	Change during Operation	Control Methods			
				V/f	V/f with PG	Open Loop Vector	Closed Loop Vector
C3-01	Slip compensation gain	1.0*	Yes	A	No	A	No
C3-02	Slip compensation delay time	200 ms*	No	A	No	A	No
C3-03	Slip compensation limit	200%	No	A	No	A	No
C3-04	Slip compensation during regeneration	0	No	A	No	A	No
C3-05	Output voltage limit operation selection	0	No	No	No	A	A

* The factory setting will change when the control method is changed. (Open Loop Vector control factory settings are given.)

■ Adjusting Slip Compensation Gain (C3-01)

The set value of C3-01 depends on the control method. The factory settings are:

- V/f control without PG: 0.0
- Open Loop Vector control: 1.0

Set C3-01 to 1.0 to compensate the slip depending on the actual torque output status using the rated slip (E2-02/E4-02) as reference.

Adjust the slip compensation gain using the following procedure.

1. With Open Loop Vector control Set E2-02 (Motor Rated Slip) and E2-03 (Motor No-load Current) correctly. The motor rated slip can be calculated using the values on the motor nameplate and the following formula:

$$\text{Motor rated slip (Hz)} = \text{Motor rated frequency (Hz)} - \frac{\text{Rated motor speed (rpm)} \times \text{Number of motor poles}}{120}$$

The motor data can be set automatically using the autotuning function.

2. With V/f control set C3-01 to 1.0.
3. Apply a load, and measure the speed to adjust the slip compensation gain. Adjust the slip compensation gain by 0.1 at a time only. If the speed is less than the target value, increase the slip compensation gain, and if the speed is higher than the target value, reduce the slip compensation gain.
4. Setting C3-01 to 0.0 disables the slip compensation function.

■ Adjusting Slip Compensation Primary Delay Time Constant (C3-02)

The slip compensation delay time constant is set in ms.

The setting value of C3-02 depends on the control method. The factory settings are:

- V/f control without PG: 2000 ms
- Open loop vector control: 200 ms

Normally, there is no need to change these settings. When the slip compensation response is low, lower the set value. When the speed is unstable, increase the set value.

■ Adjusting Slip Compensation Limit (C3-03)

Using parameter C3-03 the upper limit for the slip compensation can be set as a percentage, taking the motor rated slip as 100%.

If the speed is lower than the target value but does not change even after adjusting the slip compensation gain, the slip compensation limit may have reached. Increase the limit, and check the speed again. Always make sure that the value of the slip compensation limit and reference frequency does not exceed the tolerance of the machine.

The following diagram shows the slip compensation limit for the constant torque range and fixed output range.

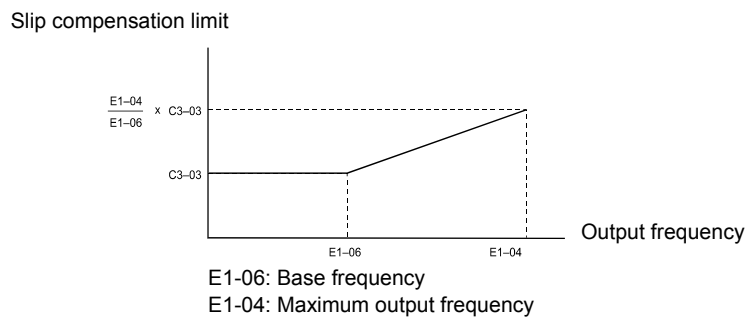

Fig 6.38 Slip Compensation Limit

■ Selecting Slip Compensation Function During Regeneration (C3-04)

Enables or disables the slip compensation function during regeneration.

If the slip compensation function operates during regeneration, you might have to use a braking option (braking resistor, braking resistor unit and braking unit).

■ Operation Selection when Output Voltage Saturated (C3-05)

Generally the Inverter cannot output a voltage that is higher than the input voltage. If the output voltage reference for the motor (monitor parameter U1-06) exceeds the input voltage in the high-speed range, the output voltage becomes saturated, and inverter cannot respond to speed or load changes. This function automatically reduces the output voltage to avoid voltage saturation.

Thereby the speed control accuracy can be maintained even at high speeds (around the rated speed of the motor). By the lowered voltage the current can be around 10% higher compared to the operation without voltage limiter.

◆ Torque Compensation for Sufficient Torque at Start and Low-speed Operation

The torque compensation function detects a rising motor load, and increases the output torque.

In V/f control the inverter calculates the motor primary loss voltage using the terminal resistance value (E2-05) and adjusts the output voltage (V) to compensate insufficient torque at startup and during low-speed operation.

The compensation voltage is calculated by the calculated Motor primary voltage loss \times parameter C4-01.

In Open Loop Vector control the motor excitation current and the torque producing current are calculated and controlled separately. The torque compensation affects the torque producing current only.

The torque producing current is calculated by the calculated torque reference \times C4-01.

■ Related Parameters

Parameter No.	Name	Factory Setting	Change during Operation	Control Methods			
				V/f	V/f with PG	Open Loop Vector	Closed Loop Vector
C4-01	Torque compensation gain	1.00	Yes	A	A	A	No
C4-02	Torque compensation delay time constant	200 ms *	No	A	A	A	No
C4-03	Starting torque compensation value (forward direction)	0.0	No	No	No	A	No
C4-04	Starting torque compensation value (reverse direction)	0.0	No	No	No	A	No
C4-05	Starting torque compensation time constant	1 ms	No	No	No	A	No

* The factory setting will change when the control method is changed. (V/f control factory settings are given.)

■ Adjusting Torque Compensation Gain (C4-01)

Normally, there is no need to change this setting. If adjustments are necessary do the following:

Open Loop Vector control:

- If the torque response is slow increase the setting value.
- If vibrations occur decrease the setting value.

V/f control:

- If the cable is very long, increase the set value.
- If the motor capacity is smaller than the Inverter capacity (max. applicable motor capacity), increase the set value.
- If the motor is vibrating, reduce the set value.

Setting precautions:

- Adjust this parameter so that the output current during low-speed rotation does not exceed the Inverter rated output current range.
- Adjust the value in steps of 0.05 only.

■ Adjusting the Torque Compensation Primary Delay Time Constant (C4-02)

The setting value of C4-02 depends on the control method. The factory settings are:

- V/f control without PG: 200 ms
- V/f control with PG: 200 ms
- Open loop vector control: 20 ms

Normally, there is no need to change this setting. If adjustments are necessary do the following:

- If the motor is vibrating, increase the set value.
- If the torque response is slow, decrease the set value.

■ Starting Torque Compensation Function (C4-03 to C4-05)

A starting torque compensation can be applied to speed up the torque establishment at start in Open Loop Vector control.

This function is effective for machinery with large friction loads and applications, where high starting torque is required. It works like shown in the following diagram.

Forward (Reverse) Run command

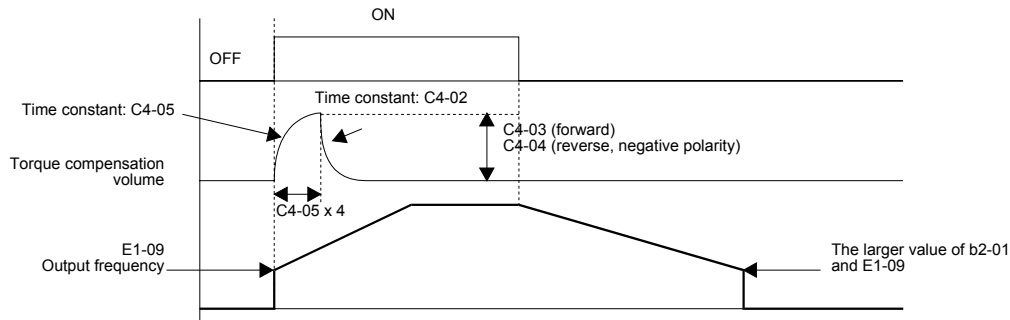

Fig 6.39 Time Chart for Starting Torque Frequency

When this function is used, the following should be considered:

- When the machine runs in FWD and REV direction both values, C4-03 and C4-04 have to be set.
- The compensation works for motoring operation only. It can not be used for regenerative operation.
- If the starting torque compensation is used and a large shock is generated at the start, increase the starting torque compensation time constant (C4-05).

◆ Automatic Speed Regulator (ASR)

In Closed Loop Vector control the automatic speed regulator (ASR) adjusts the *torque reference* in order to eliminate the deviation between the speed reference and the measured speed (PG feedback). Fig 6.40 shows the ASR structure for Closed Loop Vector control.

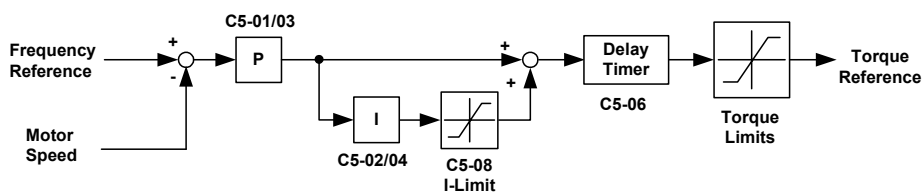

Fig 6.40 ASR Structure for Closed Loop Vector Control

In V/f control with PG the ASR adjusts the *output frequency* in order to eliminate the deviation between the speed reference and the measured speed (PG feedback). Fig 6.41 shows the ASR structure for V/f control with PG.

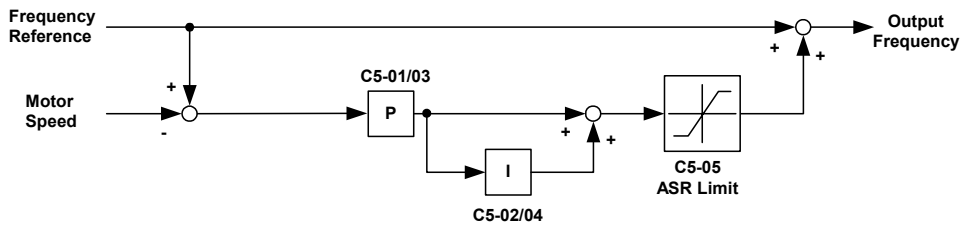

Fig 6.41 ASR Structure for V/f control with PG

■ Related Parameters

Parameter No.	Name	Factory Setting	Change during Operation	Control Methods			
				V/f	V/f with PG	Open Loop Vector	Closed Loop Vector
C5-01	ASR proportional (P) gain 1	20.00 *	Yes	No	A	No	A
C5-02	ASR integral (I) time 1	0.500 s *	Yes	No	A	No	A
C5-03	ASR proportional (P) gain 2	20.00 *	Yes	No	A	No	A
C5-04	ASR integral (I) time 2	0.500 s *	Yes	No	A	No	A
C5-05	ASR limit	5.0%	No	No	A	No	No
C5-06	ASR delay time	0.004 s	No	No	No	No	A
C5-07	ASR switching frequency	0.0 Hz	No	No	No	No	A
C5-08	ASR integral limit	400%	No	No	No	No	A
F1-07	Integral value during accel/decel enable/disable	0	No	No	A	No	No

* When the control method is changed, these values are reset to factory settings for the selected control mode. (The Closed Loop Vector control factory settings are given)

Multi-function Digital Inputs (H1-01 to H1-05)

Set Value	Function	Control Methods			
		V/f	V/f with PG	Open Loop Vector	Closed Loop Vector
D	V/f control with/without PG selection	No	Yes	No	No
E	Speed control integral operation disable	No	Yes	No	Yes
77	ASR proportional gain switch over	No	Yes	No	Yes

V/f Control with/without PG Selection: “D”

- When one of the digital inputs is set to “D” this input can be used to switch over to normal V/f control and thereby to disable the ASR.
- The ASR is disabled when the multifunction input is ON.

Speed Control Integral Disable: “E”

- When one of the digital inputs is set to “E” this input can be used to switch the speed control between PI and P control.
- P control is active when the input is ON (Integral value is reset).

ASR Gain switching: “77”

- When one of the digital inputs is set to “77” this input can be used to switch between the ASR P gains set in C5-01 and C5-03.
- If the input is enabled C5-03 will be used. If the input is disabled C5-01 will be used.

■ ASR Gain and Integral Time Adjustments for Closed Loop Vector Control

General Procedure

1. Operate the motor at zero speed.
2. Increase C5-01 (ASR proportional gain 1) to a level where no oscillation in the motor speed occurs.
3. Decrease C5-04 (ASR integral time 2) to a level where no oscillation in the motor speed occurs.
4. Increase the speed and observe the motor speed. If oscillations occur at any speed the gain must be decreased and/or the integral time must be increased.
5. If the speed is stable at all speeds the adjustment is completed.

Fine Adjustments

When an even finer ASR adjustment is required, adjust the gain and integral time while observing the speed waveform using the analog output terminals FM and AM. The necessary parameter settings are shown in the following table.

Parameter	Setting	Explanation
H4-01 Analog output selection (terminal FM)	20	Settings that allow multi-function analog output 1 to be used to monitor the frequency reference after soft starter.
H4-02 Analog output gain (terminal FM)	100%	
H4-03 Analog output bias (terminal FM)	0.0%	
H4-04 Analog output selection (terminal AM)	5	Settings that allow multi-function analog output 2 to be used to monitor the motor speed.
H4-05 Analog output gain (terminal AM)	100%	
H4-06 Analog output bias (terminal AM)	0.0%	
H4-07 Analog output 1 signal level selection	1	This setting allows a 0 to ± 10 V signal range to be monitored.
H4-08 Analog output 2 signal level selection	1	

The multi-function analog outputs have the following functions with these parameter settings.

- Analog output 1 (terminal FM): Outputs frequency reference after the soft starter (Accel./decel. ramp and S-curve) (0 to ± 10 V).
- Analog output 2 (terminal AM): Outputs actual motor speed (0 to ± 10 V).

Adjusting ASR Proportional Gain 1 (C5-01)

This gain adjusts the responsiveness of the speed control (ASR). The responsiveness is increased when this setting is increased. Oscillation will occur if this setting is increased too much. See [Fig 6.42](#) for details.

Adjusting ASR Integral Time 1 (C5-02)

This parameter sets the speed control (ASR) integral time. Lengthening the integral time lowers the responsiveness and the speed accuracy when the load changes suddenly. Oscillation can occur if this setting value is too low. See [Fig 6.42](#) for details.

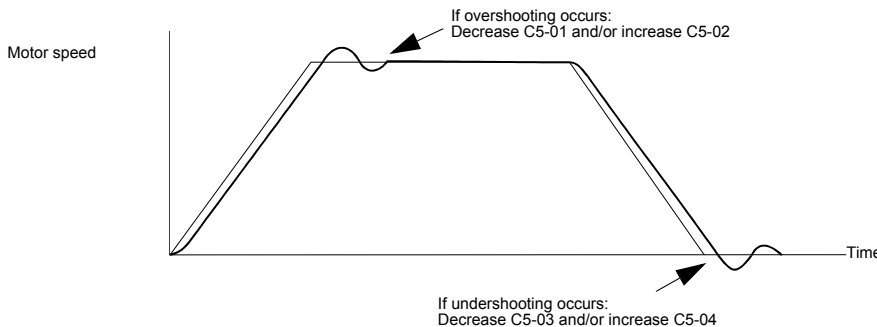

Fig 6.42 Influence of the ASR Gain and Bias

Different Gain Settings for Low-speed and High-speed

Switch between low-speed and high-speed gain when oscillation occurs because of resonance with the mechanical system at low speed or high speed. The gain and integral time can be switched according to the motor speed, as shown in Fig 6.43.

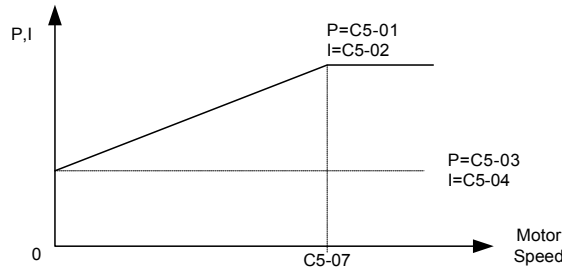

Fig 6.43 Low-speed and High-speed Gain Settings

If C5-07 is set to 0, the gain in C5-01 and the integral time in C5-02 are used for the whole speed range.

Setting the Gain Switching Frequency (C5-07)

Set the switching frequency to about 80% of the motor operating frequency or the frequency at which oscillation occurs.

Low-speed Gain Adjustments (C5-03, C5-04)

Connect the actual load and adjust these parameters at zero-speed. Increase C5-03 (ASR gain 2) and decrease C5-04 (ASR integral time 2) as long as no oscillation occurs.

High-speed Gain Adjustments (C5-01, C5-02)

Adjust these parameters at normal operating speed. Increase C5-01 (ASR gain 1) and decrease C5-02 (ASR integral time 1) as long as no oscillation occurs.

ASR Proportional Gain Switch Setting Using a Digital Input

When one of the digital inputs (H1-01 to H1-05) is set to 77, the input can be used to switch between C5-01 (ASR gain 1) and C5-03 (ASR gain 2). ASR gain 1 is used when the multi-function input is OFF, ASR gain 2 is used when the input is ON. This input has higher priority than the ASR switching frequency set in C5-07. The gain is changed linearly using the integral time 1. See Fig 6.44 for details.

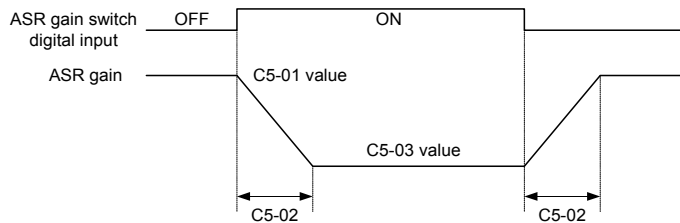

Fig 6.44 ASR Gain Switching by Digital Input

■ ASR Gain and Integral Time Adjustments for V/f control with PG

When using V/f control with PG, set the ASR gain and the integral time at E1-09 (minimum output frequency) and E1-04 (maximum output frequency). See [Fig 6.45](#) for details.

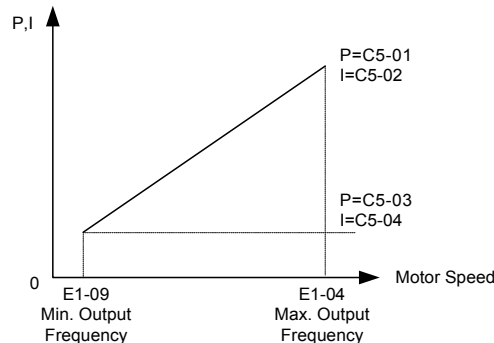

Fig 6.45 Speed Control Gain Integral Time Adjustment for V/f Control with PG

Gain Adjustments at Minimum Output Frequency (C5-03 and C5-04)

Operate the motor at the minimum output frequency. Increase C5-03 (ASR proportional gain 2) and decrease C5-04 (ASR integral time 2) as long as no oscillation occurs.

Monitor the Inverter's output current and verify that it is less than 50% of the Inverter rated current. If the output current exceeds 50% of the Inverter's rated current, decrease C5-03 and increase C5-04.

Gain Adjustments at Maximum Output Frequency (C5-01 and C5-02)

Operate the motor at the maximum output frequency. Increase C5-01 (ASR proportional gain 1) and decrease C5-02 (ASR integral time 1) as long as no oscillation occurs.

6 Fine Adjustments

When an even finer ASR adjustment is required, adjust the gain while observing the motor speed. The adjustment procedure is the same as for vector control.

Using Integral Control during Acceleration and Deceleration (F1-07)

Enable integral operation during acceleration and deceleration (by setting F1-07 to 1) if the motor speed has to follow the frequency reference closely during acceleration and deceleration. Reduce the setting of C5-01 if overshooting occurs during acceleration, and reduce the setting of C5-03 and increase the setting of C5-04 if undershooting occurs when stopping. If overshooting and undershooting cannot be eliminated by adjusting only the gain and integral time, reduce the ASR limit value (C5-05).

◆ Hunting-Prevention Function

The hunting-prevention function suppresses hunting when the motor is operating with a light load. This function can be used in the V/f control modes only.

If high response has the priority to vibration suppression this function should be disabled (N1-01 = 0).

■ Related Parameters

Parameter No.	Name	Factory Setting	Change during Operation	Control Methods			
				V/f	V/f with PG	Open Loop Vector	Closed Loop Vector
N1-01	Hunting-prevention function selection	1	No	A	A	No	No
N1-02	Hunting-prevention gain	1.00	No	A	A	No	No

■ Adjusting the Hunting-Prevention Gain (N1-02)

Normally it is not necessary to change this setting. Adjust the value under the following circumstances:

- If vibrations occur under light load condition increase the setting.
- If the motor stalls reduce the setting.

◆ Stabilizing Speed (Automatic Frequency Regulator)

The speed feedback detection control (AFR) function controls the stability of the speed when a load is suddenly applied or removed. It calculates the amount of speed fluctuation using the torque current (I_q) feedback value and compensates the output frequency with the amount of fluctuation.

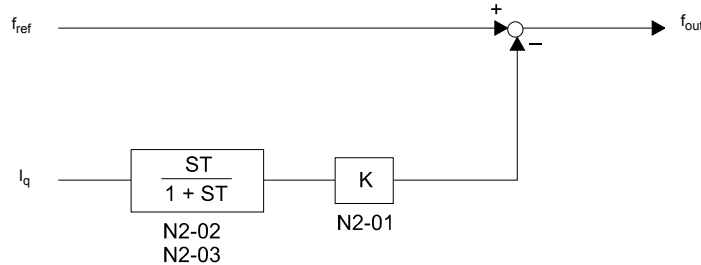

Fig 6.46 AFR Control Loop

■ Related Parameters

Parameter No.	Name	Factory Setting	Change during Operation	Control Methods			
				V/f	V/f with PG	Open Loop Vector	Closed Loop Vector
N2-01	Speed feedback detection control (AFR) gain	1.00	No	No	No	A	No
N2-02	Speed feedback detection control (AFR) time constant	50 ms	No	No	No	A	No
N2-03	Speed feedback detection control (AFR) time constant 2	750 ms	No	No	No	A	No

■ Setting the AFR Gain (N2-01)

Normally there is no need to change this setting. If adjustments are necessary do the following:

If hunting occurs increase N2-01.

If the response is too low, decrease N2-01.

Adjust the setting by 0.05 at a time while checking the response.

■ Setting the AFR Time Constants 1 and 2 (N2-02, N2-03)

Normally the setting value of N2-02 is used as AFR time constant (T in Fig 6.46). The setting value of N2-03 is used when:

L2-04 is set to 1 or 2 AND

output frequency ≥ 5 Hz AND

a transient load change occurs (causing transient regeneration or overshoot at acceleration).

Generally there is no need to change the settings.

Machine Protection

◆ Limiting Motor Torque (Torque Limit Function)

This function allows limitation of motor shaft torque independently for each of the four quadrants. The torque limit can be set as fixed value using parameters or as variable value using an analog input. The torque limit function can be used with Open Loop Vector and Closed Loop Vector control only.

■ Related Parameters

Parameter No.	Name	Factory Setting	Change during Operation	Control Methods			
				V/f	V/f with PG	Open Loop Vector	Closed Loop Vector
L7-01	Forward drive torque limit	200%*	No	No	No	A	A
L7-02	Reverse drive torque limit	200%*	No	No	No	A	A
L7-03	Forward regenerative torque limit	200%*	No	No	No	A	A
L7-04	Reverse regenerative torque limit	200%*	No	No </tr			

* A setting value of 100% is equal to the motor rated torque.

Multi-function Output (H2-01 to H2-03)

Set Value	Function	Control Methods			
		V/f	V/f with PG	Open Loop Vector	Closed Loop Vector
30	During torque limit	No	No	Yes	Yes

■ Setting the Torque Limit Using Parameters

Using L7-01 to L7-04, four torque limits in the following directions can be set individually: Forward drive, reverse drive, forward regenerative and reverse regenerative (see Fig 6.47)

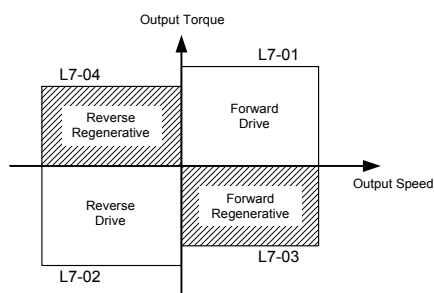

Fig 6.47 Torque Limit Parameters

■ Using a Digital Output to Signalize Operation at the Torque Limit

If a multifunction output is set for this function (H2-01 to H2-03 is set to “30”), the output is switched ON when the motor output torque reaches one of the torque limits.

■ Set the Torque Limit Value Using an Analog Input

The analog input A2 can be used to input several torque limits. The table below shows the possible analog input settings (H3-09) for the torque limit function.

Set Value	Function	100% of Contents	Control Methods			
			V/f	V/f with PG	Open Loop Vector	Closed Loop Vector
10	Positive torque limit	Motor rated torque	No	No	Yes	Yes
11	Negative torque limit	Motor rated torque	No	No	Yes	Yes
12	Regenerative torque limit	Motor rated torque	No	No	Yes	Yes
15	Positive/negative torque limit	Motor rated torque	No	No	Yes	Yes

The analog input terminal A2 signal level is factory-set as follows: 4 to 20 mA (i.e. if 20 mA are input the torque is limited to 100% of the motor rated torque). Fig 6.48 shows the relationship between the torque limits.

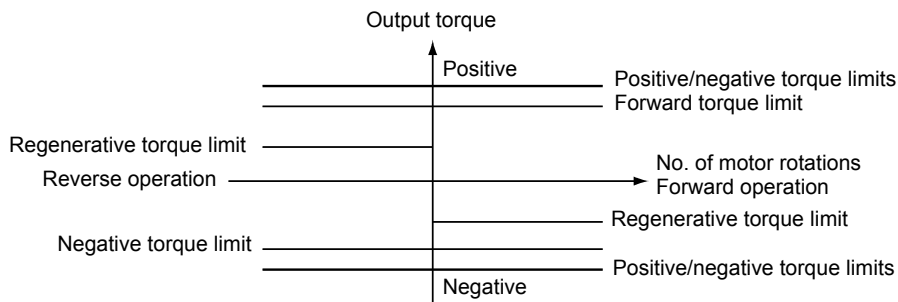

Fig 6.48 Torque Limits using the Analog Input

■ Setting Torque Limits Using Parameters and an Analog Input Together

The following block diagram shows the relationship between torque limit using parameters (L7-01 to L7-04) and torque limit using the analog input A2.

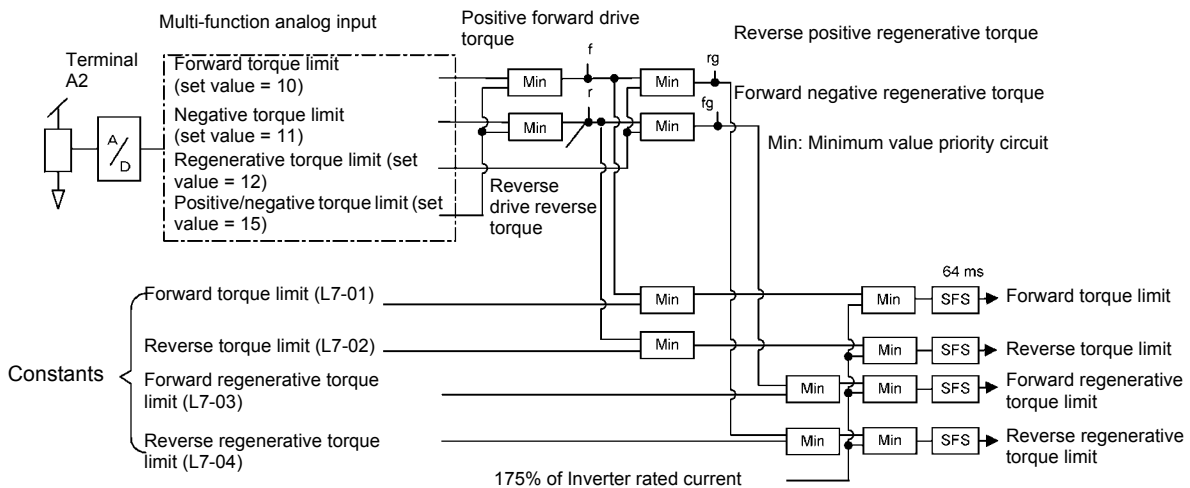

Fig 6.49 Torque Limit Using Parameters and an Analog Input Together

■ Enabling Integral Torque Limit Operation (L7-06 and L7-07)

In Open Loop Vector control an integral operation can be applied to the torque limit function (P-control is standard). This improves the torque limit responsiveness and smoothes the torque limit operation. To enable the integral operation set parameter L7-07 to 1. The integral time constant can be set in parameter L7-06.

■ **Setting Precautions**

- When the output torque reaches the torque limit, control and compensation of the motor speed is disabled to prevent the output torque from exceeding the torque limit. The torque limit has the priority.
- When using the torque limit for hoist applications, do not carelessly lower the torque limit value, as this may result in motor stalling.
- When using an analog input for torque limit setting, an analog input value of 10 V/20 mA is equal to a torque limit of 100% of the motor rated torque. To raise the torque limit value at an analog input of 10 V/20 mA for instance to 150% of the rated torque, set the input terminal gain to 150.0 (%). Adjust the gain for multi-function analog input terminal A2 using H3-10.
- The torque limit accuracy is ±5% at an output frequency of 10 Hz or above. When output frequency is lower than 10 Hz, the accuracy is lowered.

◆ **Preventing Motor Stalling During Operation**

Stall prevention during operation prevents the motor from stalling by automatically lowering the inverter output frequency when a transient overload occurs while the motor is operating at a constant speed.

Stall prevention during operation can be enabled in V/f control with/without PG only. If the Inverter output current continues to exceed the setting in parameter L3-06 for 100 ms or longer, the motor speed is reduced. Enable or disable the stall prevention using parameter L3-05. Set the according deceleration times using C1-02 (Deceleration time 1) or C1-04 (Deceleration Time 2).

If the Inverter output current reaches the set value in L3-06 – 2%, the motor will accelerate again to the set frequency.

■ **Related Parameters**

Parameter No.	Name	Factory Setting	Change during Operation	Control Methods			
				V/f	V/f with PG	Open Loop Vector	Closed Loop Vector
L3-05	Stall prevention selection during running function selection	1	No	A	A	No	No
L3-06	Stall prevention level during running	150% *	No	A	A	No	No

* The initial value when C6-01 is set to 0 is given. If C6-01 is set to 1 or 2, the initial value will be 120%.

■ **Changing Stall Prevention Level during Operation Using an Analog Input**

If H3-09 (Analog Input A2 Function Selection) is set to 8 (stall prevention during operation level), the stall level during operation can be changed using the analog input A2.

In this case the function uses either the value from the multi-function analog input terminal A2 input level or the set value in parameter L3-06. The lower value of both will be used as stall prevention level.

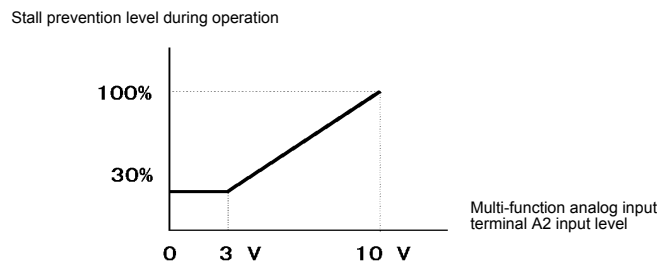

Fig 6.50 Stall Prevention Level during Operation Using an Analog Input

If the motor capacity is smaller than the Inverter capacity or the motor stalls when operating at the factory settings, lower the stall prevention level during operation.

◆ Motor Torque Detection

If an excessive load is applied to the machinery (overtorque) or the load drops suddenly (undertorque), an alarm signal can be output to one of the digital output terminals M1-M2, M3-M4, or M5-M6.

To use the overtorque/undertorque detection function, set B, 17, 18, 19 (overtorque/undertorque detection NO/NC) in one of the parameter H2-01 to H2-03 (digital output terminals M1-M2, M3-M4, and M5-M6 function selection).

Overtorque/undertorque is detected by:

- observing the output current in V/f control with or without PG (the inverter rated output current is equal to 100%).
- observing the torque reference value in Open Loop and Closed Loop Vector control (the motor rated torque is equal to 100%).

■ Related Parameters

Parameter No.	Name	Factory Setting	Change during Operation	Control Methods			
				V/f	V/f with PG	Open Loop Vector	Closed Loop Vector
L6-01	Torque detection selection 1	0	No	A	A	A	A
L6-02	Torque detection level 1	150%	No	A	A	A	A
L6-03	Torque detection time 1	0.1 s	No	A	A	A	A
L6-04	Torque detection selection 2	0	No	A	A	A	A
L6-05	Torque detection level 2	150%	No	A	A	A	A
L6-06	Torque detection time 2	0.1 s	No	A	A	A	A

Multi-function Output (H2-01 to H2-03)

Set Value	Function	Control Methods			
		V/f	V/f with PG	Open Loop Vector	Closed Loop Vector
B	Overtorque/undertorque detection 1 NO (NO contact: Overtorque detection and undertorque detection enabled when contact is ON)	Yes	Yes	Yes	Yes
17	Overtorque/undertorque detection 1 NC (NC contact: Overtorque detection and undertorque detection enabled when contact is OFF)	Yes	Yes	Yes	Yes
18	Overtorque/undertorque detection 2 NO (NO contact: Overtorque detection and undertorque detection enabled when contact is ON)	Yes	Yes	Yes	Yes
19	Overtorque/undertorque detection 2 NC (NC contact: Overtorque detection and undertorque detection enabled when contact is OFF)	Yes	Yes	Yes	Yes

Multi-Function Analog Input (H3-09)

Set Value	Function	100% of Contents	Control Methods			
			V/f	V/f with PG	Open Loop Vector	Closed Loop Vector
7	Overtorque/Undertorque Detection Level	Motor rated torque (vector control), Inverter rated current (V/f control)	Yes	Yes	Yes	Yes

■ L6-01 and L6-04 Set Values and Operator Display

The relationship between alarms displayed on the digital operator when overtorque or undertorque is detected, and the set values in L6-01 and L6-04, is shown in the following table.

Set Value	Function	Operator Display	
		Overtorque/Undertorque Detection 1	Overtorque/Undertorque Detection 2
0	Overtorque/undertorque detection disabled.	–	–
1	Overtorque detection only with speed agree; operation continues (warning is output).	OL3 flashes	OL4 flashes
2	Overtorque detected continuously during operation; operation continues (warning is output).	OL3 flashes	OL4 flashes
3	Overtorque detection only with speed agree; output is stopped upon detection.	OL3 lights up	OL4 lights up
4	Overtorque detected continuously during operation; output is stopped upon detection.	OL3 lights up	OL4 lights up
5	Undertorque detection only with speed agree; operation continues (warning is output).	UL3 flashes	UL4 flashes
6	Undertorque detected continuously during operation; operation continues (warning is output).	UL3 flashes	UL4 flashes
7	Undertorque detection only with speed matching; output is stopped upon detection.	UL3 lights up	UL4 lights up
8	Undertorque detected continuously during operation; output is stopped upon detection.	UL3 lights up	UL4 lights up

■ Timing Charts

Fig 6.51 and Fig 6.52 show the timing charts for overtorque and undertorque detection.

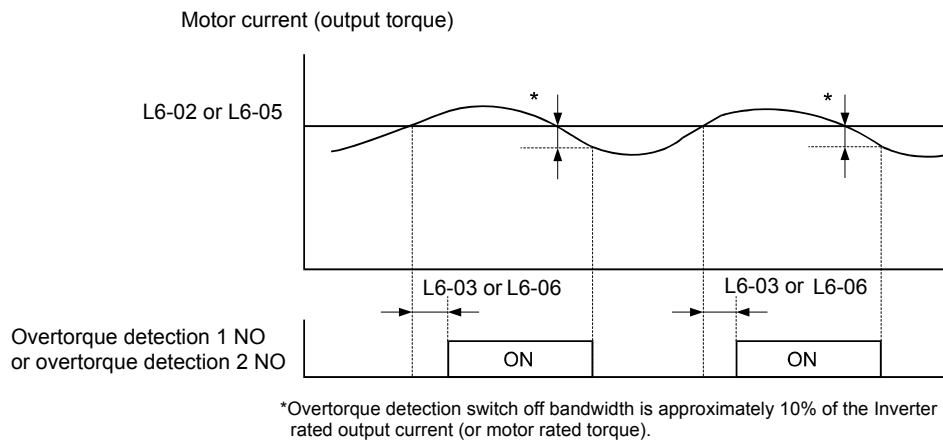

Fig 6.51 Overtorque Detection

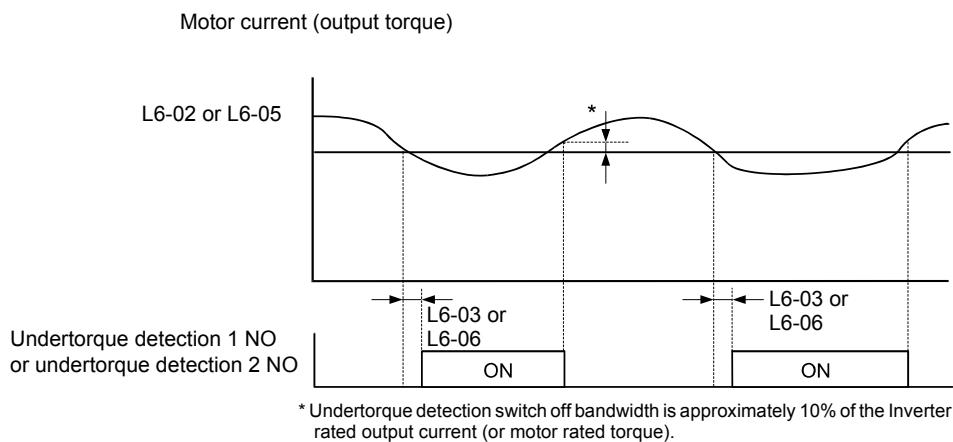

Fig 6.52 Undertorque Detection

■ Changing Overtorque and Undertorque Detection Levels Using an Analog Input

If parameter H3-09 (Analog Input A2 Function Selection) is set to 7 (overtorque/undertorque detection level), the overtorque/undertorque detection level can be changed using the analog input A2 (refer to [Fig 6.53](#)).

Only the overtorque/undertorque detection level 1 can be changed using the analog input. Overtorque/undertorque detection level 2 cannot be changed by an analog input signal.

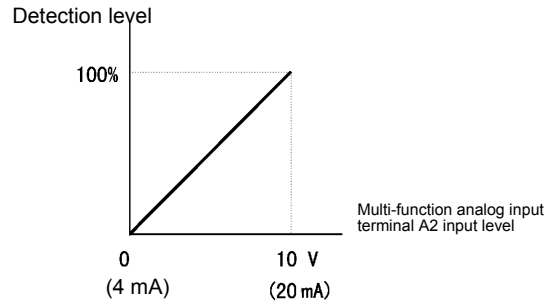

Fig 6.53 Overtorque/Undertorque Detection Level Using an Analog Input

◆ Motor Overload Protection

The motor can be protected from overload using the built-in electronic thermal overload relay function.

■ Related Parameters

Parameter No.	Name	Factory Setting	Change during Operation	Control Methods			
				V/f	V/f with PG	Open Loop Vector	Closed Loop Vector
E2-01	Motor rated current	1.90 A *	No	Q	Q	Q	Q
E4-01	Motor 2 rated current	1.90 A *	No	A	A	A	A
L1-01	Motor protection selection	1	No	Q	Q	Q	Q
L1-02	Motor protection time constant	1.0 min	No	A	A	A	A

* Factory settings depend on Inverter capacity. (The values shown are for a 200 V Class Inverter with 0.4 kW.)

Multi-Function Outputs (H2-01 to H2-03)

Set Value	Function	Control Methods			
		V/f	V/f with PG	Open Loop Vector	Closed Loop Vector
1F	Motor overload (OL1, including OH3) pre-alarm (ON: 90% or more of the detection level)	Yes	Yes	Yes	Yes

■ Setting Motor Rated Current (E2-01 and E4-01)

Set the rated current value on the motor nameplate in parameters E2-01 (for motor 1) and E4-01 (for motor 2). This set value is the base current for the internal thermal overload calculation.

■ Setting Motor Overload Protection Characteristics (L1-01)

Set the overload protection function in L1-01 according to the used motor.

The induction motor's cooling abilities vary with the motor type. Consequently, you must select the electronic thermal protection characteristics.

Set L1-01 to:

0: to disable the thermal motor protection function.

1: to enable the thermal motor protection for a fan cooled general purpose motor (self-cooled).

2: to enable the thermal motor protection for an inverter motor (externally cooled).

3: to enable the thermal motor protection for a special vector motor (externally cooled).

■ Setting Motor Protection Operation Time (L1-02)

The motor protection operation time is the time for that the motor can handle a 150% overload when it was running with the rated load before (i.e. operating temperature was reached before applying the 150% overload). Set the motor protection operation time in L1-02. The factory setting is 60 sec.

Fig 6.54 shows an example of the characteristics of the electronic thermal protection operation time (L1-02 = 1.0 min., operation at 60 Hz, general-purpose motor characteristics, when L1-01 is set to 1)

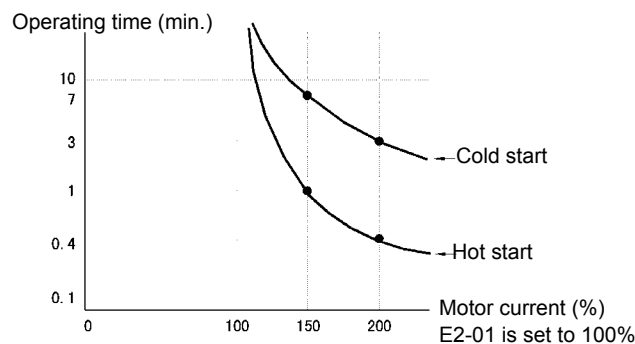

Fig 6.54 Motor Protection Operation Time

■ Setting Precautions

- If multiple motors are connected to one inverter, set parameter L1-01 to 0 (disabled). To protect each of the motors, use a control circuit that switches off the inverter output when one of the motors overheats.
- With applications where the power supply is often turned ON and OFF, there is a risk that the motor cannot be protected even if this parameter has been set to 1 (enabled), because the thermal value will be reset after inverter power supply switch off.
- For safe overload tripping, set the value in parameter L1-02 to a low setting.
- When using a general-purpose motor (standard motor), the cooling ability will be lowered by $f^{1/4}$ (frequency). Consequently, a low output frequency may cause motor overload protection (OL1) to occur, even when the output current is below the rated current. If the motor is operated at the rated current at a low frequency, use a special motor which is externally cooled.

■ Setting a Motor Overload Pre-Alarm

If the motor overload protection function is enabled (i.e., L1-01 is set to a value different from 0) and you set H2-01 to H2-03 (output terminals M1-M2, M3-M4, and M5-M6 function selection) to 1F (motor overload OL1 pre-alarm), the motor overload pre-alarm will be output at. If the electronic thermal value reaches minimum 90% of the overload detection level, the output terminal that has been set will be turned ON.

◆ Motor Overheating Protection Using PTC Thermistor Inputs

This function provides a motor overheating protection using a thermistor (PTC characteristic – Positive Temperature Coefficient) which is built into the windings of each motor phase. The thermistor must be connected to an analog input.

■ Related Parameters

Parameter No.	Name	Factory Setting	Change during Operation	Control Methods			
				V/f	V/f with PG	Open Loop Vector	Closed Loop Vector
L1-03	Alarm operation selection during motor overheating	3	No	A	A	A	A
L1-04	Motor overheating operation selection	1	No	A	A	A	A
L1-05	Motor temperature input filter time constant	0.20 s	No	A	A	A	A

Multi-Function Analog Input (H3-09)

Set Value	Function	100% of Contents	Control Methods			
			V/f	V/f with PG	Open Loop Vector	Closed Loop Vector
E	Motor temperature input	-	Yes	Yes	Yes	Yes

■ PTC Thermistor Characteristics

Fig 6.55 shows the characteristics of the PTC thermistor temperature to the resistance value.

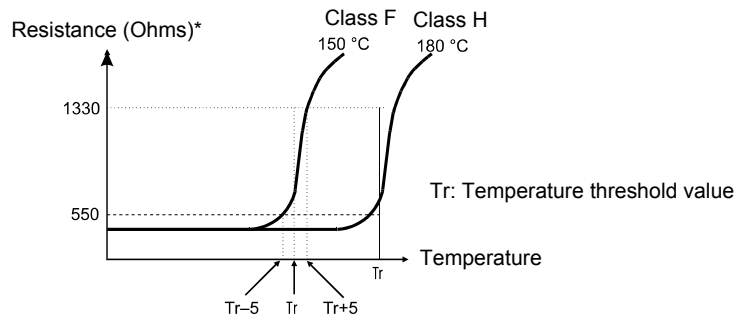

* The shown resistance value is for one motor phase. Normally the 3 resistors are connected in series.

Fig 6.55 PTC Thermistor Temperature-Resistance Value Characteristics

■ Operation during Motor Overheating

The operation when the motor overheats can be selected using the parameters L1-03 and L1-04. A motor overheat detection filter time can be set in parameter in L1-05 to prevent wrong over heat faults.

If the motor temperature rises to the motor overheat pre-alarm level, an OH3 alarm is shown at the display and the operation is continued like set in L1-03.

If the operation is continued and the motor temperature rises further to the motor overheat detection level, an OH4 fault is shown at the display and the operation is stopped.

Terminal Connection

The terminal connection for the motor overheat function is shown in *Fig 6.56*. The following points have to be considered:

- Pin 2 of the DIP-switch S1 on the control terminal board has to be turned to OFF for A2 voltage input. The factory setting is ON (A2 current input).
- Parameter H3-09 has to be set to “E”
- Parameter H3-08 (analog input terminal A2 signal level) has to be set to 0 (0-10V input).

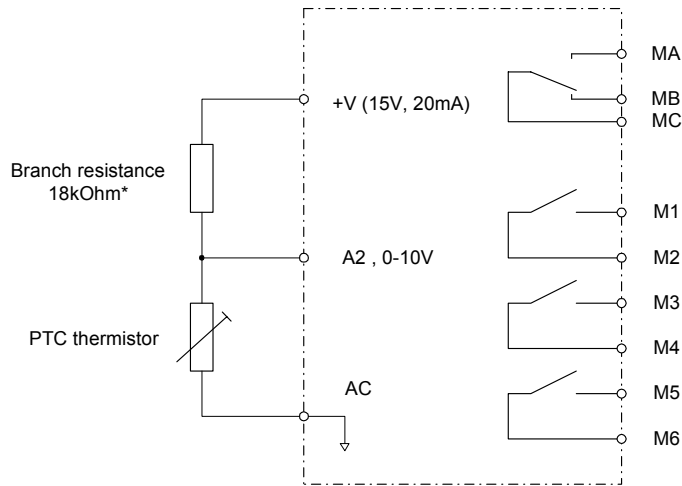

*1The resistance value of 18 kΩ is only valid when a 3-phase PTC with the characteristic shown on the previous page is used.

Fig 6.56 Terminal Connections for Motor Overheating Protection

Limiting Motor Rotation Direction and Output Phase Rotation

If the motor reverse rotation is prohibited, a reverse run command will not be accepted, even if it is input. Use this setting for applications in which reverse motor rotation can cause problems (e.g., fans, pumps, etc.)

In V/F mode it is also possible to change the output phase order by changing a parameter. This is much easier and faster than changing the wiring if the motor rotational direction is wrong. If this function is used a prohibition of reverse direction is not possible.

Related Parameters

Parameter Number	Name	Description	Setting Range	Factory Setting	Change during Operation	Control Methods			
						V/f	V/f with PG	Open Loop Vector	Closed Loop Vector
b1-04	Prohibition of reverse operation	0: Reverse enabled 1: Reverse disabled	0 or 2	0	No	A	A	A	A
		2: Output Phase Rotation				A	No	No	No

Automatic Restart

This section explains functions for continuing or automatically restarting inverter operation after a momentary power loss.

◆ Restarting Automatically After Momentary Power Loss

If a temporary power loss occurs, the inverter can be restarted automatically to continue motor operation.

To restart the Inverter after the power has returned, set L2-01 to 1 or 2.

If L2-01 is set to 1, the inverter will restart as long as the power is recovered within the time set in L2-02. If the power loss time exceeds the time set in L2-02, an UV1 alarm (DC bus undervoltage) will be detected.

If L2-01 is set to 2, the inverter will restart, when the main power supply is recovered as long as the control power supply (i.e., power supply to the control circuit) is maintained. Consequently, alarm UV1 (DC bus undervoltage) will not be detected.

■ Related Parameters

Parameter No.	Name	Factory Setting	Change during Operation	Control Methods			
				V/f	V/f with PG	Open Loop Vector	Closed Loop Vector
L2-01	Momentary power loss detection	0	No	A	A	A	A
L2-02	Momentary power loss ride through time	0.1 s *1	No	A	A	A	A
L2-03	Min. baseblock (BB) time	0.1 s	No	A	A	A	A
L2-04	Voltage recovery time	0.3 s*1	No	A	A	A	A
L2-05	Undervoltage (UV) detection level	190 V *2	No	A	A	A	A

* 1. Factory settings depend on Inverter capacity. (The values shown are for a 200 V Class Inverter for 0.4 kW.)

* 2. These values are for a 200 V Class Inverter. For a 400 V Class Inverter, double the values.

■ Setting Precautions

- Error output signals are not output during momentary power loss recovery.
- To continue Inverter operation after the power has been restored, make the settings so that RUN commands from the control main circuit terminal are stored even while power is suspended.
- If the momentary power loss operation selection is set to 0 (Disabled), an alarm UV1 (main circuit undervoltage) will be detected when the momentary power loss exceeds 15 ms during operation.

◆ Speed Search

The speed search function detect the actual speed of a motor that is coasting without control and restart it smoothly from that speed. It is also activated after momentary power loss detection when L2-01 is set to enabled.

■ Related Parameters

Parameter No.	Name	Factory Setting	Change during Operation	Control Methods			
				V/f	V/f with PG	Open Loop Vector	Closed Loop Vector
b3-01	Speed search selection (current detection or speed calculation)	2* ¹	No	A	A	A	No
b3-02	Speed search operating current (current detection)	120%	No	A	No	A	No
b3-03	Speed search deceleration time (current detection)	2.0 s	No	A	No	A	No
b3-05	Speed search wait time (current detection or speed calculation)	0.2 s	No	A	A	A	A
b3-10	Speed search compensation gain	1.10	No	A	No	A	No
b3-14	Speed search rotation selection direction	1	No	A	A	A	No
L2-03	Min. baseblock time	0.1 s * ¹	No	A	A	A	A
L2-04	Voltage recovery time	0.3 s * ²	No	A	A	A	A

* 1. The factory setting will change when the control method is changed. (Open loop vector control factory settings are given.)

* 2. Factory settings depend on Inverter capacity. (The values shown are for a 200 V Class Inverter for 0.4 kW.)

Multi-function Digital Inputs

Set Value	Function	Control Methods			
		V/f	V/f with PG	Open Loop Vector	Closed Loop Vector
61	External search command 1 OFF: Speed search disabled (Start from lowest output frequency) ON: Speed calculation: Calculates the motor speed, and starts search from calculated speed Current detection: Starts speed search from maximum output frequency	Yes	No	Yes	No
62	External search command 2 OFF: Speed search disabled (Start from lowest output frequency) ON: Speed calculation: Calculates the motor speed, and starts search from calculated speed, same operation as external search command 1 Current detection: Starts speed search from set frequency (reference frequency when search command was input).	Yes	No	Yes	No
64	External search command 3 OFF: Inverter is base blocked ON: Inverter starts operation using speed search (same operation as speed search 2)	Yes	Yes	Yes	Yes

■ Setting Precautions

- When both external search commands 1 and 2 are set for the multi-function contact terminals, an OPE03 (invalid multi-function input selection) operation error will occur. Set either external search command 1 or external search command 2.
- If speed search during startup is selected when using V/f control with PG or Closed Loop Vector control the unit will start from the frequency detected by PG.
- If performing speed search using external search commands, design the control circuit so that the run command and external search command are both ON. These two commands must be kept on, at least for the time set in parameter L2-03.
- If the Inverter output is equipped with a contactor, set the contactor operation delay time in the Speed Search Wait Time (b3-05). The factory setting is 0.2 s. When not using a contactor, you can reduce the search time to 0.0 s. After waiting for the speed search wait time, the Inverter starts the speed search.
- Parameter b3-02 (current detection level for search completion) is effective only when current detection speed search is selected. When the current falls below the detection level, the speed search is supposed to be as completed, and the motor accelerates or decelerates to the set frequency.
- If an overcurrent (OC) is detected when using speed search after power recovery, lengthen the Minimum Baseblock Time (L2-03).

■ Application Precautions for Speed Searches Using Estimated Speed

- When using V/f control with or without a PG, always perform stationary autotuning for line-to-line resistance before using speed searches based on calculated speeds.
- When using Open Loop or Closed Loop Vector control, always perform rotational autotuning before using speed searches based on calculated speeds.
- If the cable length between the motor and Inverter is changed after autotuning has been performed, perform stationary autotuning for line-to-line resistance again.

■ Speed Search Selection

The speed search method can be selected using b3-01. If b3-01 is set to 0 the search method is speed calculation. It has to be activated by a multi-function input (H1-□□ set to 61 or 62).

If b3-01 is set to 1, the search method is speed calculation too, but speed search is performed at every RUN command and has not to be activated by a multifunction input.

The same is valid for setting b3-01 to 2 or 3, only the search method is current detection instead of speed calculation.

Refer to the table below to see the differences of both search methods.

Search Name	Speed Calculation	Current Detection
Search Method	Calculates the motor speed when the search starts, and accelerates or decelerates from the calculated speed to the set frequency. The direction of motor rotation is also detected.	Starts speed search from the frequency when the temporary power loss was detected, or from the highest frequency, and performs speed detection by watching the current level during the search.
External Speed Search Command	External search command 1 and external search command 2 become the same operation calculation of the motor speed and starting the search from the calculated speed.	External speed search command 1: Starts speed search from the maximum output frequency. External speed search command 2: Starts speed search from the frequency reference set before the search command.
Application Precautions	Cannot be used with multi-motor drives, with motors two or more sizes smaller than the Inverter capacity, and high-speed motors (higher than 130 Hz)	In control method without PG, the motor may accelerate suddenly with light loads.

Speed Calculation

Search at Startup

The time chart for when speed search at startup and speed search to multi-function input terminals is shown below.

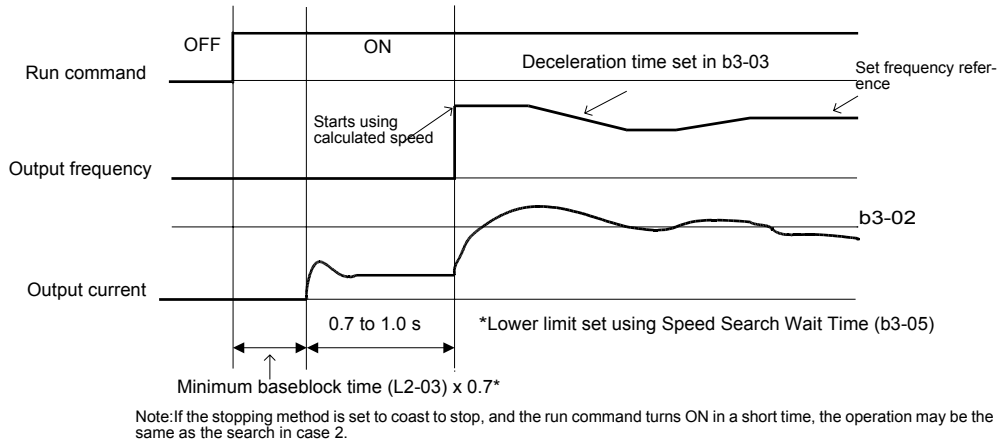

Fig 6.57 Speed Search at Startup (Calculated Speed)

Speed Search after Power Loss

- Loss Time shorter than the Minimum Baseblock Time (L2-03)

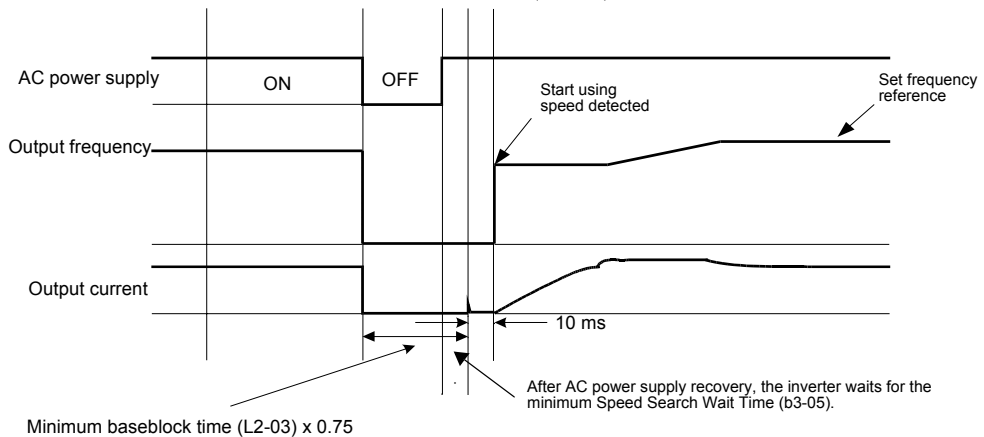

Fig 6.58 Speed Search after Power Loss with Loss Time < L2-03

- Loss Time longer than the Minimum Baseblock Time (L2-03)

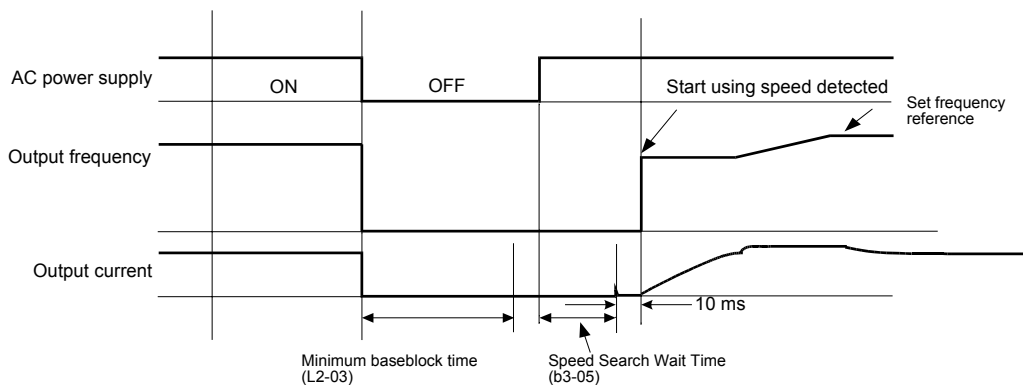

Fig 6.59 Speed Search after Power Loss with Loss Time > L2-03

■ Current Detection

Speed Search at Startup

The time chart when speed search at startup or external speed search command is selected is shown below.

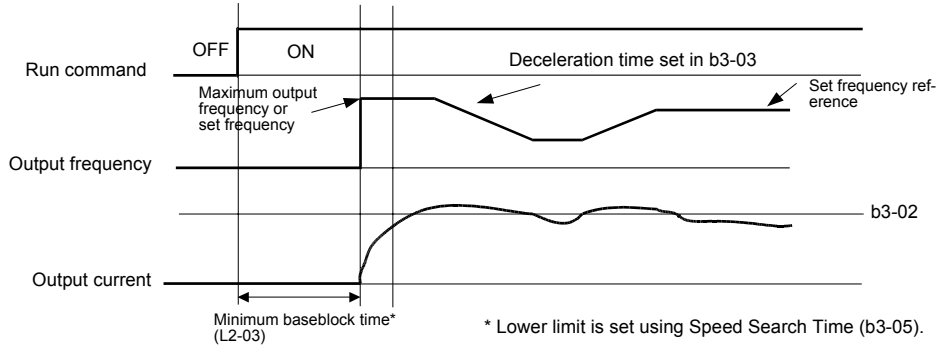

Fig 6.60 Speed Search at Startup (Current Detection)

Speed Search after Power Loss

- Loss time shorter than minimum baseblock time

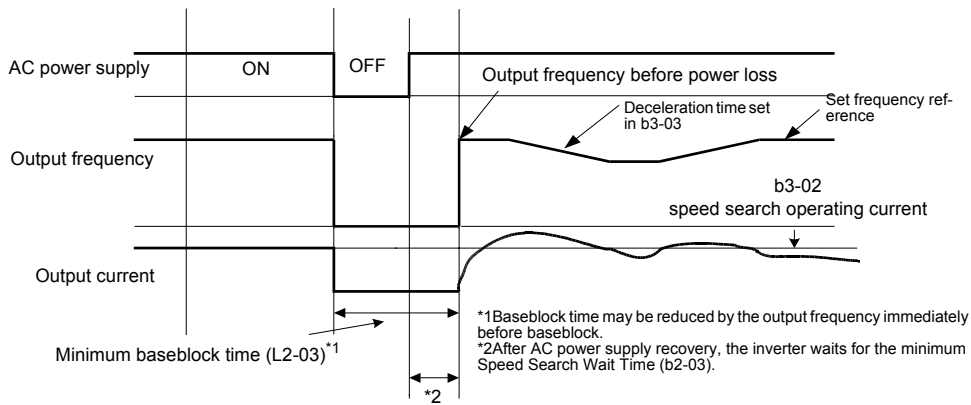

Fig 6.61 Speed Search after Power Loss Time < L2-03

- Loss time longer than minimum baseblock time

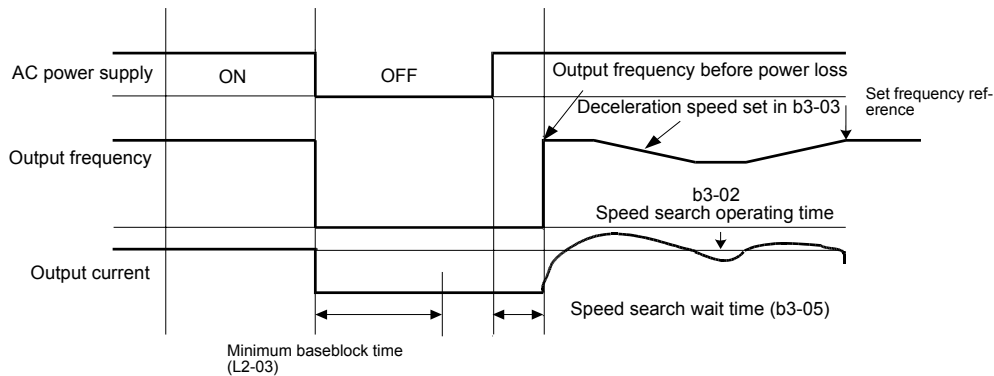

Fig 6.62 Speed Search after Power Loss with Loss Time > L2-03

◆ Continuing Operation at Constant Speed when the Frequency Reference is Lost

The frequency reference loss detection function detects a loss of the frequency reference value. If an analog frequency reference source is selected, a frequency reference loss is detected, when the reference value drops over 90% in 400 ms or less.

The operation after a reference loss can be set in parameter L5-01 as follows:

- L5-01=0 The inverter operation is stopped.
- L5-01=1 The operation is continued at reduced speed using the set value in parameter L4-06 as frequency reference value.

When an error signal during frequency reference loss shall be output externally, set H2-01 to H2-03 (multi-function contact output terminal M1-M2, M3-M4, and M5-M6 function selection) to C (frequency reference lost).

■ Related Parameters

Parameter No.	Name	Factory Setting	Change during Operation	Control Methods			
				V/f	V/f with PG	Open Loop Vector	Closed Loop Vector
L4-05	Operation when frequency reference is missing	0	No	A	A	A	A
L4-06	Output frequency adjustment after freq. reference loss	80%	No	A	A	A	A

Multi-function Contact Outputs (H2-01 to H2-03)

Set Value	Function	Control Methods			
		V/f	V/f with PG	Open Loop Vector	Closed Loop Vector
C	Frequency reference loss	Yes	Yes	Yes	Yes

◆ Restarting Operation After Transient Error (Auto Restart Function)

If an Inverter error occurs during operation, the Inverter will perform self-diagnosis. If no error is detected, the Inverter will automatically restart. This is called the auto restart function.

Set the number of auto restarts in parameter L5-01.

The auto restart function can be applied to the following errors.

- OC (Overcurrent)
- GF (Ground fault)
- PUF (DC bus fuse blown)
- OV (Main circuit overvoltage)
- UV1 (Main Circuit Undervoltage, Main Circuit MC Operation Failure)*
- PF (Main circuit voltage fault)
- LF (Output phase failure)
- RH (Braking resistor overheated)
- RR (Braking transistor error)
- OL1 (Motor overload)
- OL2 (Inverter overload)
- OH1 (Motor overheat)
- OL3 (Overtorque 1)
- OL4 (Overtorque 2)

* When L2-01 is set to 1 or 2 (continue operation during momentary power loss)

If an error that is not listed above occurs, the protection function will operate and the auto restart function will not work.

■ Auto Restart External Outputs

To output auto restart signals externally, set H2-01 to H2-03 (multi-function contact output terminals M1-M2, M3-M4, and M5-M6 function selection) to 1E (auto restart).

■ Related Parameters

Parameter No.	Name	Factory Setting	Change during Operation	Control Methods			
				V/f	V/f with PG	Open Loop Vector	Closed Loop Vector
L5-01	Number of auto restart attempts	0	No	A	A	A	A
L5-02	Auto restart operation selection	0	No	A	A	A	A

Multi-function Contact Outputs (H2-01 to H2-03)

Set Value	Function	Control Methods			
		V/f	V/f with PG	Open Loop Vector	Closed Loop Vector
1E	Automatic restart enabled	Yes	Yes	Yes	Yes

■ Application Precautions

The number of auto restarts counter is reset under the following conditions:

- After auto restart, normal operation has continued for 10 minutes.
- After the protection operation has been performed and an error reset has been input.
- After the power supply is turned OFF, and then ON again.

Inverter Protection

◆ Overheating Protection for an Inverter-Mounted Braking Resistor

This function provides overheat protection for inverter-mounted braking resistors (Model: ERF-150WJ □□).

When overheating of a mounted braking resistor is detected, an fault RH (mounted braking resistor overheating) is displayed on the Digital Operator, and the motor coasts to stop.

The fault can be output using one of the multi-function contact outputs as well. Therefore one of the parameters H2-01 to H2-03 has to be set to D.

■ Related Parameters

Parameter No.	Name	Factory Setting	Change during Operation	Control Methods			
				V/f	V/f with PG	Open Loop Vector	Closed Loop Vector
L8-01	Protection selection for internal DB resistor (Type ERF)	0	No	A	A	A	A

Multi-function Contact Outputs (H2-01 to H2-03)

Set Value	Function	Control Methods			
		V/f	V/f with PG	Open Loop Vector	Closed Loop Vector
D	Braking resistor fault (ON: Resistor overheats or brake transistor fault)	Yes	Yes	Yes	Yes



INFO

The most likely causes of RH (Mounted braking resistor overheating) faults are that the deceleration time is too short or that the motor regeneration energy is too large. In these cases, lengthen the deceleration time or replace the Braking Resistor with one with a higher braking capacity.



IMPORTANT

This function is not applicable for protecting external braking resistors. When external braking resistors are used together with the internal braking chopper, L8-01 should be set to 0 to disable the internal braking resistor protection.

◆ Inverter Overheat Protection

The Inverter is protected against overheating using a thermistor that detects the heatsink temperature.

When the overheat temperature level is reached the inverter output is switched off.

To prevent a suddenly and unexpected stop of the inverter due to an over temperature, an overheating pre-alarm can be output. The temperature level for that pre-alarm can be set in parameter L8-02. Using parameter L8-03 the inverter operation when an over temperature occurs can be selected.

If a multifunction output is programmed for this function the output is switched ON when the heatsink temperature exceeds the overheat pre-alarm level set in L8-02.

■ Related Parameters

Parameter No.	Name	Factory Setting	Change during Operation	Control Methods			
				V/f	V/f with PG	Open Loop Vector	Closed Loop Vector
L8-02	Overheat pre-alarm level	95°C	No	A	A	A	A
L8-03	Inverter overheat (OH) pre-alarm operation selection	3	No	A	A	A	A

Multifunction Outputs (H2-01 to H2-03)

Set Value	Function	Control Methods			
		V/f	V/f with PG	Open Loop Vector	Closed Loop Vector
20	Inverter overheat (OH)	Yes	Yes	Yes	Yes

6

◆ Input Open Phase Protection

For the Input Phase Loss Detection the drive monitors the DC bus ripple. The drive integrates this ΔV value over 10 scans (approximately 10 seconds). If the integrated ΔV value of any consecutive ten scan range is greater than the voltage determined by multiplying L8-06 times the drives rated OV Trip point (400Vdc/800Vdc), a PF fault will occur and the Drive will coast to stop

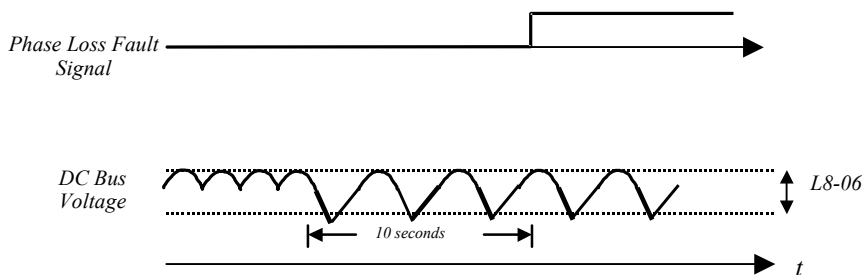

Fig 6.63 Input Phase Loss Detection

■ Related Parameters

Parameter No.	Name	Factory Setting	Change during Operation	Control Methods			
				V/f	V/f with PG	Open Loop Vector	Closed Loop Vector
L8-05	Input open-phase protection selection	1	No	A	A	A	A

Generally it is not recommended to disable this function.

◆ Output Open Phase Protection

This function detects an open output phase by comparing the output current value of each phase with an internal set output open phase detection level (5% of inverter rated current). The detection will not work when the output frequency is below 2% of the base frequency (E1-13).

Three settings are available:

- L8-07=0, no output open phase detection
- L8-07=1, the loss of one phase is detected only
- L8-07=2, the loss of 2 or 3 phases is detected as well

■ Related Parameters

Parameter No.	Name	Factory Setting	Change during Operation	Control Methods			
				V/f	V/fwith PG	Open Loop Vector	Closed Loop Vector
L8-07	Output open-phase protection selection	0	No	A	A	A	A

The function should be disabled if the motor capacity is very low compared to the inverter capacity. Otherwise wrong output open phase errors might be detected.

◆ Ground Fault Protection

This function detects the earth leakage current by calculating the sum of the three output currents. Normally it should be 0. If the earth leakage current gets too high, the inverter output will be switched off and a GF fault is shown on the display. The fault contact is activated.

■ Related Parameters

Parameter No.	Name	Factory Setting	Change during Operation	Control Methods			
				V/f	V/fwith PG	Open Loop Vector	Closed Loop Vector
L8-09	Ground protection selection	1	No	A	A	A	A

It is not recommended to disable this function.

◆ Cooling Fan Control

This function controls the fan which is mounted to the inverters heatsink.

■ Related Parameters

Parameter No.	Name	Factory Setting	Change during Operation	Control Methods			
				V/f	V/fwith PG	Open Loop Vector	Closed Loop Vector
L8-10	Cooling fan control selection	0	No	A	A	A	A
L8-11	Cooling fan control delay time	60 s	No	A	A	A	A

■ Selecting the Cooling Fan Control

Using parameter L8-10 two modes can be selected:

0: The fan is ON only when the inverter output is ON, i.e. a voltage is output. This is the factory setting.

1: The fan is ON whenever the inverter power supply is switched ON.

If L8-10 is set to 0, the turn OFF delay time for the fan can be set in parameter L8-11. After a stop command the inverter waits for this time before switching OFF the cooling fan. The factory setting is 60 sec.

◆ Setting the Ambient Temperature

At high ambient temperatures an output current derating has to be considered. The derating depends on the ambient temperature and the protective structure of the inverter. The ambient temperature derating curve is shown in Fig 6.64. To ensure a safe inverter protection at high ambient temperatures, always set parameter L8-15 to the actual ambient temperature.

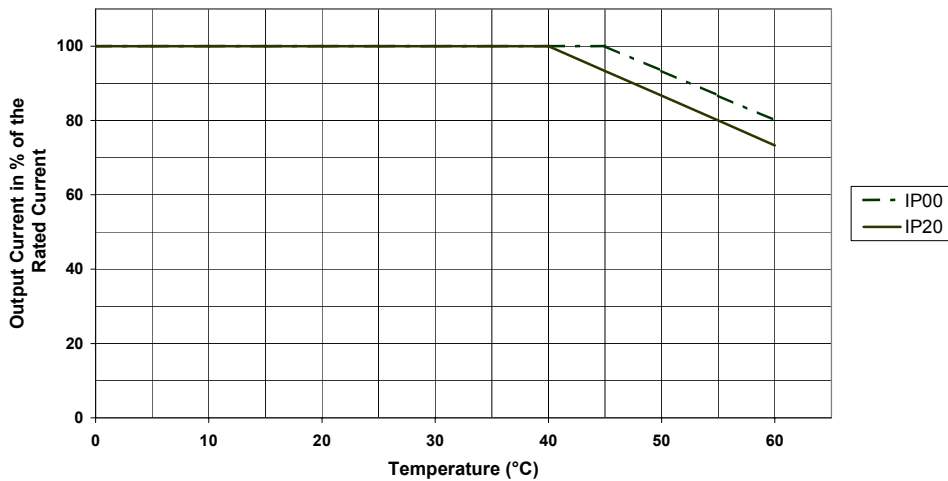

Fig 6.64 Ambient Temperature Derating Curve

■ Related Parameters

Parameter No.	Name	Factory Setting	Change during Operation	Control Methods			
				V/f	V/f with PG	Open Loop Vector	Closed Loop Vector
L8-12	Ambient temperature	45 °C	No	A	A	A	A



Since the inverter has no IP00/IP20 detection, at IP20 units the ambient temperature value in L8-12 has to be set 5° higher than the actual ambient temperature.

◆ OL2 Characteristics at Low Speed

At output frequencies below 6 Hz the overload capability of the inverter is lower than at higher speeds, i.e. an OL2 fault (inverter overload) may occur even if the current is below the normal OL2 current level (see [Fig. 6.61](#)).

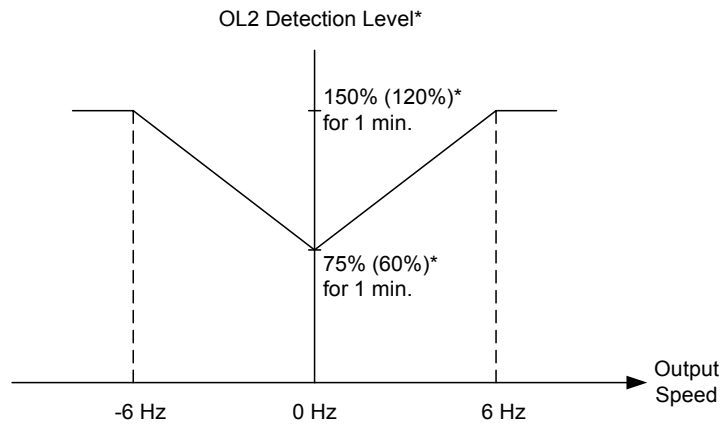

* Note that the OL2 level depends on the setting of C6-01. The values are given for Heavy Duty. The values in parentheses are for Normal Duty 1 or 2.

Fig 6.65 OL2 Alarm Level at Low Frequencies

■ Related Parameters

Parameter No.	Name	Factory Setting	Change during Operation	Control Methods			
				V/f	V/fwith PG	Open Loop Vector	Closed Loop Vector
L8-15	OL2 characteristics selection at low speeds	1	No	A	A	A	A

Generally it is not recommended to disable this function.

Input Terminal Functions

◆ Temporarily Switching Operation between Digital Operator and Control Circuit Terminals

The Inverter run command inputs and frequency reference inputs can be switched over between Local and Remote.

- Local: The digital operator is used as frequency reference and run command source.
- Remote: The frequency reference and run command source can be set in the parameters b1-01 and b1-02.

If any input from H1-01 to H1-05 (digital input terminal S3 to S7 function selection) has been set to 1 (local/remote selection), this input can be used to switch over between local and remote.

■ Related Parameters

Parameter No.	Name	Factory Setting	Change during Operation	Control Methods			
				V/f	V/f with PG	Open Loop Vector	Closed Loop Vector
b1-01	Reference selection	1	No	Q	Q	Q	Q
b1-02	RUN command source selection	1	No	Q	Q	Q	Q

Multi-function Digital Inputs (H1-01 to H1-05)

Set Value	Function	Control Methods			
		V/f	V/f with PG	Open Loop Vector	Closed Loop Vector
1	Local/Remote selection (ON: Operator, OFF: b1-01/02)	Yes	Yes	Yes	Yes



INFO

Local/Remote switching can also be performed using the LOCAL/REMOTE key on the Digital Operator. When the Local/Remote function has been set for one external terminal, the LOCAL/REMOTE key function on the Digital Operator will be disabled.

◆ Blocking the Inverter Output (Baseblock Commands)

Using a baseblock command the inverter output can be stopped immediately. In this case the motor will start coasting. If the baseblock command is cleared, the inverter output operation is resumed.

If speed search is enabled, the inverter detects the motor speed and the operation is resumed from the detected speed.

If speed search is disabled, the operation is resumed from the frequency reference which was active before the baseblock command.

To use the baseblock function one of the digital inputs must be set for baseblock, i.e. one of the parameters H1-01 to H1-05 (digital input terminal S3 to S7 function selection) must be set to 8 or 9 (Baseblock command NO/NC).

Multi-function Digital Inputs (H1-01 to H1-05)

Set Value	Function	Control Methods			
		V/f	V/f with PG	Open Loop Vector	Closed Loop Vector
8	External baseblock NO (Normally Open contact: Baseblock when ON)	Yes	Yes	Yes	Yes
9	External baseblock NC (Normally Closed contact: Baseblock when OFF)	Yes	Yes	Yes	Yes

■ Timing Chart

The timing chart when using a baseblock command is shown in [Fig 6.66](#).

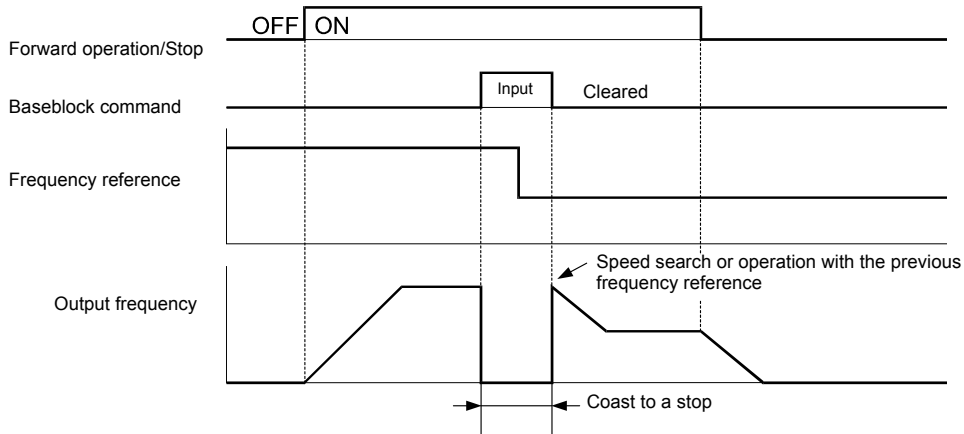

Fig 6.66 Baseblock Commands



When a contactor between inverter and motor is used, always perform a base block command before opening the contactor.

◆ OH2 (Overheat) Alarm Signal Input

Set Value	Function	Control Methods			
		V/f	V/f with PG	Open Loop Vector	Closed Loop Vector
B	OH2 Alarm input (ON: OH2 is displayed)	Yes	Yes	Yes	Yes

If a digital input is programmed for this function (H1-□□=B) an OH2 alarm message can be displayed on the display by turning this input to ON. The fault contact will not be operated.

◆ Multifunction Analog Input A2 Disable/Enable

Set Value	Function	Control Methods			
		V/f	V/f with PG	Open Loop Vector	Closed Loop Vector
C	Analog Input A2 enable/disable (ON: Enable)	Yes	Yes	Yes	Yes

If a digital input is programmed for this function (H1-□□=C) the analog input A2 can be enabled or disabled by switching the digital input ON/OFF (ON – Analog Input A2 enabled).

◆ Drive Enable/Disable

Set Value	Function	Control Methods			
		V/f	V/f with PG	Open Loop Vector	Closed Loop Vector
6A	Enable/Disable drive (ON: drive enabled)	Yes	Yes	Yes	Yes

If a digital input is programmed for this function (H1-□□=6A) the drive can be enabled or disabled by switching the digital input ON/OFF (ON – Drive enabled).

If the input is switched OFF while a RUN command is active the inverter will stop using the stopping method set in b1-03.

◆ Stopping Acceleration and Deceleration (Acceleration/Deceleration Ramp Hold)

- A multi-function input can be used to pause the acceleration or deceleration and maintain (hold) the output frequency. To program one digital input for this function one of the parameters H1-01 to H1-05 has to be set to 6A.
- The acceleration/deceleration is hold when the input is turned ON.
- The acceleration/deceleration is restarted when the acceleration/deceleration ramp hold input is turned OFF.
- The motor will be stopped if a stop command is input while the acceleration/deceleration ramp hold input is ON.
- When parameter d4-01 (the frequency reference hold function selection) is set to 1, the held frequency will be stored in memory. This stored frequency will be retained as frequency reference even after a power loss and the motor will be restarted at this frequency when a run command is input again.

■ Related Parameters

Parameter No.	Name	Factory Setting	Change during Operation	Control Methods			
				V/f	V/f with PG	Open Loop Vector	Closed Loop Vector
d4-01	Frequency reference hold function selection	0	No	A	A	A	A

Multi-function Digital Inputs (H1-01 to H1-05)

Set Value	Function	Control Methods			
		V/f	V/f with PG	Open Loop Vector	Closed Loop Vector
A	Acceleration/deceleration ramp hold (ON: hold is active)	Yes	Yes	Yes	Yes

■ Timing Chart

The timing chart when using Acceleration/Deceleration Ramp Hold commands is shown in Fig 6.67.

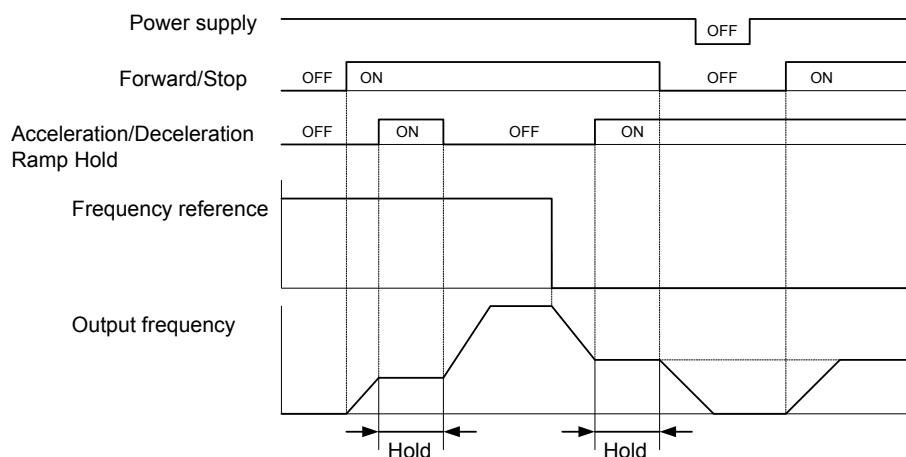

Fig 6.67 Acceleration/Deceleration Ramp Hold

◆ Raising and Lowering Frequency References Using Contact Signals (UP/DOWN)

Using the UP and DOWN commands the frequency references can be raised or lowered by switching a pair of digital inputs.

To use this function, set two of the parameters H1-01 to H1-05 (digital input terminal S3 to S7 function selection) to 10 (UP command) and 11 (DOWN command). Be sure to allocate two terminals so that the UP and DOWN commands are used as a pair. Otherwise an OPE03 alarm will be displayed.

The table below shows the possible combinations of the UP and DOWN commands and the corresponding operation.

Operation	Acceleration	Deceleration	Hold	
Up command	ON	OFF	ON	OFF
Down command	OFF	ON	ON	OFF

The change of the output frequency depends on the acceleration and deceleration times. Be sure to set b1-02 (Run command selection) to 1 (Control circuit terminal).

Multi-function Digital Inputs (H1-01 to H1-05)

Set Value	Function	Control Methods			
		V/f	V/f with PG	Open Loop Vector	Closed Loop Vector
10	Up command	Yes	Yes	Yes	Yes
11	Down command	Yes	Yes	Yes	Yes

■ Precautions

Setting Precautions

If multi-function input terminals S3 to S7 are set as follows, operation error OPE03 (Invalid multi-function input selection) will occur:

- Only either the UP command or DOWN command has been set.
- UP/DOWN commands and Acceleration/Deceleration Ramp Hold have been allocated at the same time.

Application Precautions

- Frequency references which use the UP/DOWN commands are limited by the frequency reference upper and lower limits set in parameters d2-01 to d2-03. In this case the value from the input A1 becomes the frequency reference lower limit. If using a combination of the frequency reference from terminal A1 and the frequency reference lower limit set in either parameter d2-02 or d2-03, the larger limit value will become the frequency reference lower limit.
- If the UP/DOWN commands are used as frequency reference and the run command is input the inverter accelerates to the frequency reference lower limit which is set in d2-02.
- When using UP/DOWN commands, multi-step operations are disabled.
- When d4-01 (Frequency Reference Hold Function Selection) is set to 1, the frequency reference value using the UP/DOWN functions is stored even after the power supply is turned OFF. When the power supply is turned ON and the run command is input, the motor accelerates to the frequency reference that has been stored. To reset (i.e., to 0 Hz) the stored frequency reference, turn ON the UP or DOWN command while the run command is OFF.

■ Connection Example and Timing Chart

The time chart and settings example when the UP command is allocated to the digital input terminal S3, and the DOWN command is allocated to terminal S4, are shown below.

Parameter	Name	Set Value
H1-01	Multi-function input (terminal S3)	10
H1-02	Multi-function input (terminal S4)	11

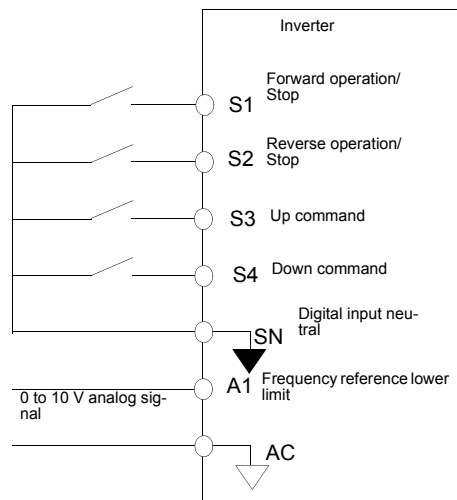
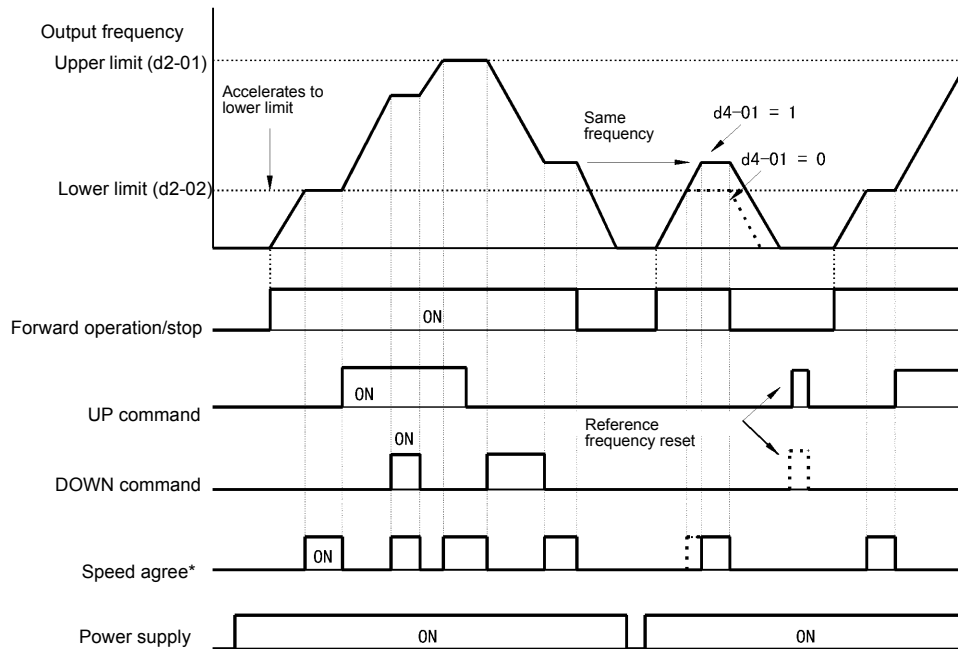

Fig 6.68 Connection Example when UP/DOWN Commands Are Allocated



* The speed agree signal turns ON when the motor is not accelerating/decelerating while the run command is ON.

Fig 6.69 UP/DOWN Commands Timing Chart

◆ Adding/Subtracting a Fixed Speed to an Analog Reference (Trim Control)

The trim control function adds or subtracts the value of parameter d4-02 to/from an analog frequency reference.

To use this function, set two of the parameters H1-01 to H1-05 (multi-function contact terminal inputs S3 to S7 function selection) to 1C (Trim Control Increase command) and 1D (Trim Control Decrease command). Be sure to allocate two terminals so that the Trim Control Increase command and Trim Control Decrease command are used as a pair. Otherwise an OPE03 alarm will be displayed.

■ Related Parameters

Parameter No.	Name	Factory Setting	Change during Operation	Control Methods			
				V/f	V/f with PG	Open Loop Vector	Closed Loop Vector
d4-02	Trim control speed limits	10%	No	A	A	A	A

Multi-function Digital Inputs (H1-01 to H1-05)

Set Value	Function	Control Methods			
		V/f	V/f with PG	Open Loop Vector	Closed Loop Vector
1C	Trim control increase	Yes	Yes	Yes	Yes
1D	Trim control decrease	Yes	Yes	Yes	Yes

■ Trim Control Increase/Decrease Command and Frequency Reference

The frequency references using Trim Control Increase/Decrease command ON/OFF operations are shown below.

Frequency Reference	Set Frequency Reference + d4-02	Set Frequency Reference - d4-02	HOLD	
Trim Control Increase Command Terminal	ON	OFF	ON	OFF
Trim Control Decrease Command Terminal	OFF	ON	ON	OFF

■ Application Precautions

- Trim Control Increase/Decrease command is enabled when speed reference > 0 and the speed reference source is an analog input (A1 or A2).
- When the (analog frequency reference value - d4-02) < 0, the frequency reference is set to 0.
- If only one of the Trim Control Increase command or Trim Control Decrease command has been set for a digital input terminal, operation error OPE03 (invalid multi-function input selected) will occur.

◆ Hold Analog Frequency Using User-set Timing

When one of the parameters H1-01 to H1-05 (digital input terminal S3 to S7 function selection) is set to 1E (sample/hold analog frequency command), the analog frequency reference will be held from 100 ms after the terminal is turned ON, and operation will continue at that frequency.

The analog value 100 ms after the command is turned ON is used as the frequency reference.

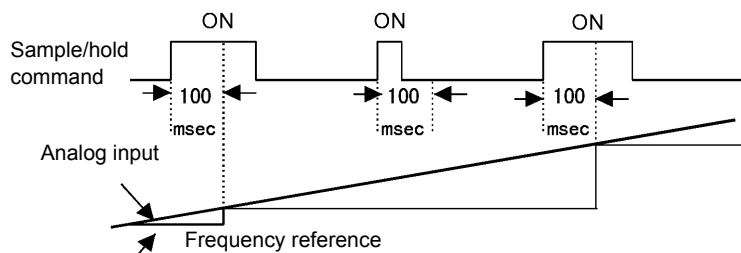

Fig 6.70 Sample/hold Analog Frequency

■ Related Parameters

Multi-function Digital Inputs (H1-01 to H1-05)

Set Value	Function	Control Methods			
		V/f	V/f with PG	Open Loop Vector	Closed Loop Vector
1E	Analog frequency reference sample / hold	Yes	Yes	Yes	Yes

■ Precautions

When setting and executing sample and hold for analog frequency references, observe the following precautions.

Setting Precautions

When using sample/hold of analog frequency reference, you cannot use the following commands at the same time. Otherwise operation error OPE03 (invalid multi-function input selection) will occur.

- Acceleration/Deceleration Ramp Hold command
- UP/DOWN command
- Trim Control Increase/Decrease command

Application Precautions

- When performing sample/hold of analog frequency reference, be sure to close the digital input for 100 ms or more. If the sample/hold time is less than 100 ms, the frequency reference will not be held.
- The frequency reference value that is held will be deleted when the power supply is turned OFF.

◆ Switching Operation Source to Communication Option Card

The source of frequency reference and RUN command can be switched between a Communication option card and the sources selected in b1-01 and b1-02. Set one of the parameters H1-01 to H1-05 (digital inputs S3 to S7 function selection) to 2 to enable operation source switch over.

If a RUN command is active, the switch over will not be accepted.

■ Related Parameters

Multi-function Digital Inputs (H1-01 to H1-05)

Set Value	Function	Control Methods			
		V/f	V/f with PG	Open Loop Vector	Closed Loop Vector
2	Operation source selection: Option Card/ Inverter (ON: Inverter settings in b1-01 and b1-02, OFF: Option Card)	Yes	Yes	Yes	Yes

■ Setting Precautions

To use the operation source switching function make the following settings:

- Set b1-01 (frequency reference source) to a value different from 3 (option card).
- Set b1-02 (RUN command source) to a value different from 3 (option card).
- Set one of the parameters H1-01 to H1-02 to 2.

◆ Jog Frequency with Direction Commands (FJOG/RJOG)

The FJOG/RJOG function operates the inverter at the jog frequency. It can be activated by using the terminal ON/OFF operation. When using the FJOG/RJOG commands, there is no need to input the RUN command.

To use this function, set one of the parameters H1-01 to H1-05 (digital input terminal S3 to S7 function selection) to 12 (FJOG command) or 13 (RJOG command).

■ Related Parameters

Parameter No.	Name	Factory Setting	Change during Operation	Control Methods			
				V/f	V/f with PG	Open Loop Vector	Closed Loop Vector
d1-17	Jog frequency reference	6.00 Hz	Yes	Q	Q	Q	Q

Multi-Function Digital Inputs (H1-01 to H1-05)

Set Value	Function	Control Methods			
		V/f	V/f with PG	Open Loop Vector	Closed Loop Vector
12	FJOG command (ON: Forward run at jog frequency d1-17)	Yes	Yes	Yes	Yes
13	RJOG command (ON: Reverse run at jog frequency d1-17)	Yes	Yes	Yes	Yes

■ Application Precautions

- Jog frequencies using FJOG and RJOG commands have the priority over other frequency references.
- When both FJOG command and RJOG commands are ON for 500 ms or longer at the same time, the Inverter stops according to the setting in b1-03 (stopping method selection).

◆ Stopping the Inverter on External Device Errors (External Error Function)

The external error function activates the error contact output and stops the Inverter operation. Using this function the inverter operation can be stopped on peripheral devices break down or other errors. The digital operator will display EFx (External error [input terminal Sx]). The x in EFx shows the number of the terminal at which the external error signal is input. For example, if an external error signal is input to terminal S3, EF3 will be displayed.

To use the external error function, set one of the values 20 to 2F in one of the parameters H1-01 to H1-05 (digital input terminal S3 to S7 function selection).

Select the value to be set in H1-01 to H1-05 from a combination of any of the following three conditions.

- Signal input level from peripheral devices
- External error detection method
- Operation after external error detection

The following table shows the relationship between the combinations of conditions and the set value in H1-□□.

Set Value	Input Level (See Note *1)		Error Detection Method (See Note *2)		Operation During Error Detection			
	NO Contact	NC Contact	Constant Detection	Detection During Operation	Decelerate to Stop (Error)	Coast to Stop (Error)	Emergency Stop (Error)	Continue Operation (Warning)
20	Yes		Yes		Yes			
21		Yes	Yes		Yes			
22	Yes			Yes	Yes			
23		Yes		Yes	Yes			
24	Yes		Yes			Yes		
25		Yes	Yes			Yes		
26	Yes			Yes		Yes		
27		Yes		Yes		Yes		
28	Yes		Yes				Yes	
29		Yes	Yes				Yes	
2A	Yes			Yes			Yes	
2B		Yes		Yes			Yes	
2C	Yes		Yes					Yes
2D		Yes	Yes					Yes
2E	Yes			Yes				Yes
2F		Yes		Yes				Yes

* 1. Sets the input level at which errors are detected. (NO contact: External error when ON; NC contact: External error when OFF).

* 2. Set the detection method to detect errors using either constant detection or detection during operation.
 Constant detection: Detects while power is supplied to the Inverter.
 Detection during operation: Detects only during Inverter operation.

Output Terminal Functions

The digital multifunction outputs can be set for several functions using the H2-01 to H2-03 parameters (terminal M1 to M6 function selection). These functions are described in the following section.

■ Related Parameters

Parameter No.	Name	Factory Setting	Change during Operation	Control Methods			
				V/f	V/f with PG	Open Loop Vector	Closed Loop Vector
H2-01	Terminal M1-M2 function selection	0	No	A	A	A	A
H2-02	Terminal M3-M4 function selection	1	No	A	A	A	A
H2-03	Terminal M5-M6 function selection	2	No	A	A	A	A

■ During Run (Setting: 0) and During Run 2 (Setting: 37)

During Run (Setting: 0)

OFF	The Run command is OFF and there is not output voltage.
ON	The Run command is ON or a voltage is being output.

During Run 2 (Setting: 37)

OFF	The inverter is not outputting a frequency. (Baseblock, DC injection braking or stopped)
ON	The inverter is outputting a frequency.

These outputs can be used to indicate the inverter's operating status.

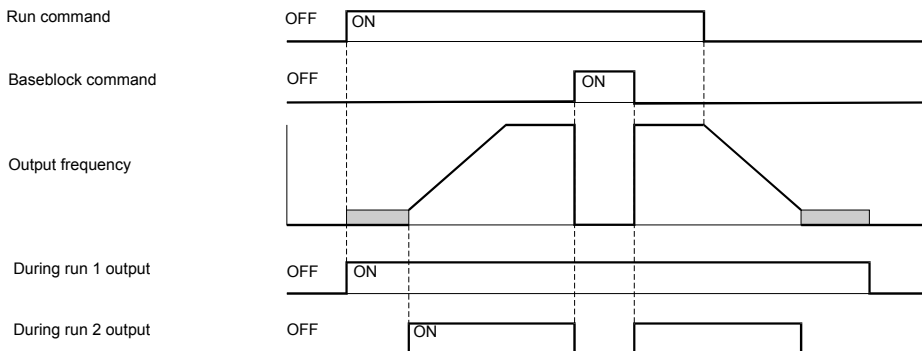

Fig 6.71 Timing Chart for "During RUN" Output

■ Zero Speed (Setting: 1)

OFF	The output frequency is higher than the zero speed level (b2-01).
ON	The output frequency is lower than the zero speed level (b2-01).

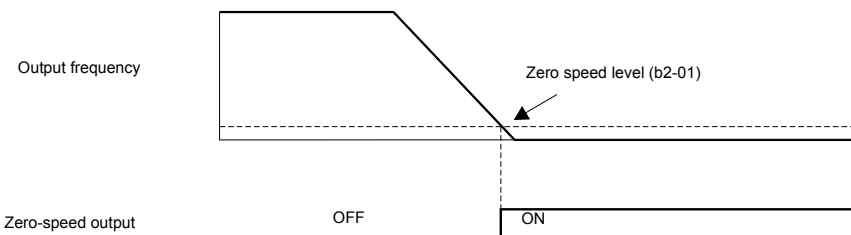

Fig 6.72 Timing Chart for Zero-speed

■ Inverter Operation Ready (Setting: 6)

If a multifunction output is programmed for this function the output will be switched ON when the initialisation of the inverter at startup has finished without any faults.

■ During DC Bus Undervoltage (Setting: 7)

If a multifunction output is programmed for this function the output is switched ON as long as a DC bus undervoltage is detected.

■ During Baseblock (Setting: 8)

If a multifunction output is programmed for this function the output is switched ON as long as the inverter output is base blocked.

■ Frequency Reference Source Selection (Setting: 9)

If a multifunction output is programmed for this function the output is ON when the digital operator is selected as frequency reference source. If any other frequency reference is selected the output is switched OFF.

■ Run Command Selection Status (Setting: A)

If a multifunction output is programmed for this function the output is switched ON when the digital operator is selected as RUN command source. If any other RUN command source is selected output is switched OFF.

■ Fault Output (Setting: E)

If a multifunction output is programmed for this function the output is switched ON when any fault different from CPF00 and CPF01 occurs. The output is also not switched at minor faults. (Refer to [page 7-2](#) pp. for a fault list.)

■ Minor Fault Output (Setting: 10)

If a multifunction output is programmed for this function the output is switched ON when a minor fault occurs (refer to [page 7-9](#) pp. for an alarm list).

■ Fault Reset Command Active (Setting: 11)

If a multifunction output is set for this function the output is switched ON as long as a fault reset command is input at one of the digital inputs.

■ During Reverse Run (Setting: 1A)

If a multifunction output is programmed for this function the output is switched ON whenever a RUN command in reverse direction is active. The contact will also be ON during DC injection, Braking and Base Block. It will not work when a forward RUN command is input.

■ During Base Block 2 (Setting: 1B)

If a multifunction output is programmed for this function the output is switched OFF as long as a Baseblock command is input at a multifunction input.

■Motor 2 Selection (Setting: 1C)

If a multifunction output is programmed for this function the output is switched ON when motor 2 is selected.

■During Regenerative Operation (Setting: 1D)

If a multifunction output is programmed for this function the output is switched ON when the motor works regenerative, i.e. when energy is fed back to the inverter.

■During Run 2 (Setting: 37)

When a multifunction output is set to this function the output is switched ON when a frequency is output. It will be switched OFF during Baseblock, DC injection braking or Stop.

■Drive Enabled (Setting: 38)

If a multifunction output is programmed for this function the output is switched ON when the drive is enabled. The drive can be enabled or disabled using a digital multifunction input.

Monitor Parameters

◆ Using the Analog Monitor Outputs

This section explains the usage of the internal analog monitor outputs.

■ Related Parameters

Parameter No.	Name	Factory Setting	Change during Operation	Control Methods			
				V/f	V/fwith PG	Open Loop Vector	Closed Loop Vector
H4-01	Monitor selection (terminal FM)	2	No	A	A	A	A
H4-02	Gain (terminal FM)	100%	Yes	Q	Q	Q	Q
H4-03	Bias (terminal FM)	0.0%	Yes	A	A	A	A
H4-04	Monitor selection (terminal AM)	3	No	A	A	A	A
H4-05	Gain (terminal AM)	50%	Yes	Q	Q	Q	Q
H4-06	Bias (terminal AM)	0.0%	Yes	A	A	A	A
H4-07	Analog output 1 signal level selection (FM)	0	No	A	A	A	A
H4-08	Analog output signal 2 level selection (AM)	0	No	A	A	A	A

■ Selecting Analog Monitor Items

Some of the digital operator monitor items (U1-□□ [status monitor]) can be output at the multi-function analog output terminals FM-AC and AM-AC. Refer to [page 5-64, Status Monitor Parameters: U1](#) and set the parameter number of U1 group (□□ part of U1-□□) for the parameters H4-01 or H4-04.

■ Adjusting the Analog Monitor Items

Adjust the output current/voltage for multi-function analog output terminals FM-AC and AM-AC using the gain and bias in H4-02, H4-03, H4-05, and H4-06.

The gain sets the analog output voltage/current value which is equal to 100% of the monitor item.

The bias sets the analog output voltage/current value which is equal to 0% of the monitor item.

Note that the maximum output voltage/current is 10V/20mA. A voltage/current higher than these values can not be output.

Adjustment Examples

The influence of the settings of gain and bias on the analog output channel is shown on three examples in [Fig 6.69](#).

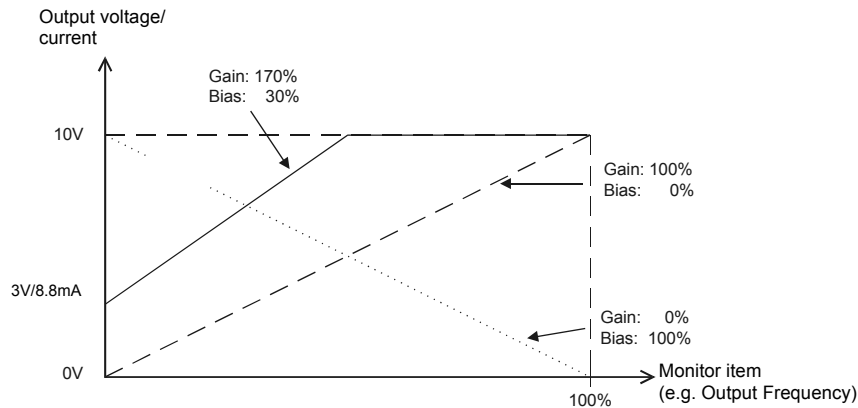

Fig 6.73 Monitor Output Adjustment

Switching Analog Monitor Signal Levels

The values of some monitor items can be both, positive or negative. If these items shall be output at an analog output, the signal level should be set to $-10V$ to $+10V$ ($H4-07/08 = 1$). Negative values will be output as negative voltage ($-10V$ to 0) and positive values will be output as positive voltage (0 to $+10V$).

For monitor items that can have positive or negative values please refer to [page 5-64, Status Monitor Parameters: U1](#).

Both analog outputs can create a 4-20 mA current signal as well. Therefore the parameters H4-07 and H4-08 have to be set to 2. Additionally the jumper CN15 has to be set to current output for each channel. Refer to [page 2-23, Jumper CN15 and DIP Switch S1](#) for details about the jumper setting.

Using the Pulse Train Monitor Output

Related Parameters

Parameter No.	Name	Factory Setting	Change during Operation	Control Methods			
				V/f	V/f with PG	Open Loop Vector	Closed Loop Vector
H6-06	Pulse train monitor selection	2	Yes	A	A	A	A
H6-07	Pulse train monitor scaling	1440 Hz	Yes	A	A	A	A

Selecting Pulse Monitor Items

Some of the digital operator monitor items ($U1-□□$ [status monitor]) can be output at pulse monitor terminal MP-AC. Refer to [page 5-64, Status Monitor Parameters: U1](#) and set the $□□$ part of $U1-□□$ (Status monitor) for H6-06.

Adjusting the Pulse Monitor Items

To adjust the pulse frequency output scaling, set the pulse output frequency which is equal to 100% of the monitor item in parameter H6-07.

Set H6-06 to 2, and H6-07 to 0, to output the frequency synchronous with the Inverter's U-phase output frequency.

■ Application Precautions

When using the pulse monitor output, connect a peripheral device according to the following load conditions. If the load conditions are different, there is a risk of characteristic insufficiency or damage to the inverter.

Output Voltage (Isolated) VRL (V)	Load Impedance
+5 V min.	1.5 k Ω min.
+8 V min.	3.5 k Ω min.
+10 V min.	10 k Ω min.

External Power Supply (V)	12 VDC \pm 10%, 15 VDC \pm 10%
Max. Current	16 mA

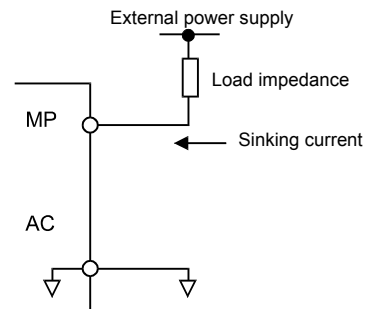
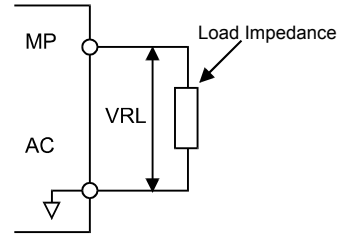

Individual Functions

◆ Using MEMOBUS Communications

Serial communications with a Programmable Logic Controls (PLCs) or similar devices can be performed using the MEMOBUS protocol.

■ MEMOBUS Communications Configuration

MEMOBUS communications are configured using 1 master (PLC) and a maximum of 31 slaves. Serial communications between master and slave are normally started by the master and the slaves respond.

The master performs serial communications with only one slave at a time. Consequently, you must set the address of each slave before, so that the master can perform serial communications using that address. A slave that receives a command from the master performs the specified function and sends a response to the master.

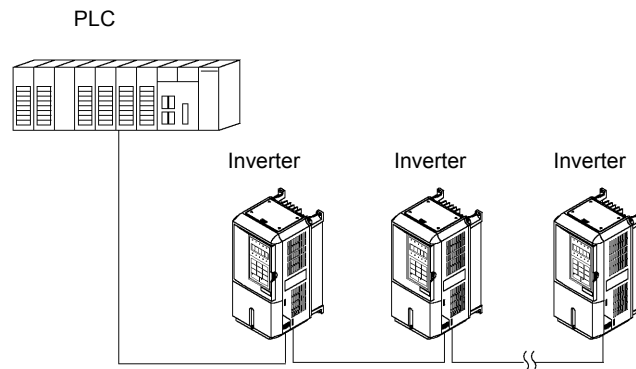

Fig 6.74 Example of Connections between PLC and Inverter

■ Communications Specifications

The MEMOBUS communications specifications are shown in the following table.

Item	Specifications
Interface	RS-422, RS-485
Communications Cycle	Asynchronous (Start-stop synchronization)
Communications Parameters	Baud rate: Select from 1,200, 2,400, 4,800, 9,600 and 19,200 bps.
	Data length: 8 bits fixed
	Parity: Select from even, odd, or none.
	Stop bits: 1 bit fixed
Communications Protocol	MEMOBUS
Number of Connectable Units	31 units max.

■ Communications Connection Terminal

The MEMOBUS communications use the following terminals: S+, S-, R+, and R-. Enable the terminating resistance by turning ON pin 1 of switch S1 for the last Inverter (seen from the PLC) only.

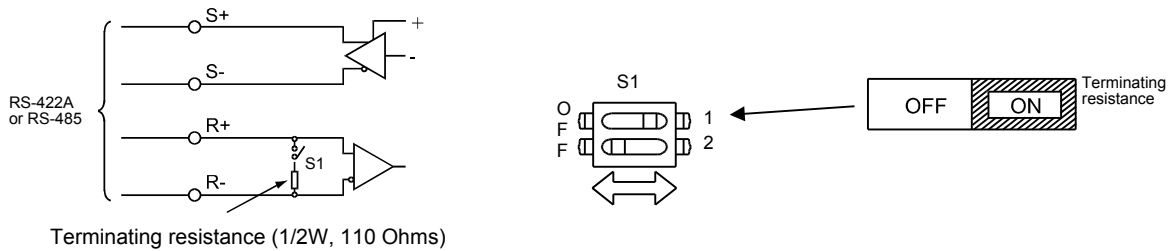
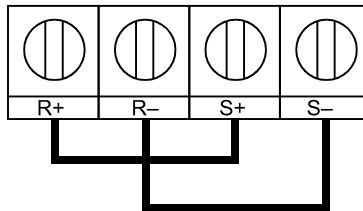

Fig 6.75 Communications Terminal Connection



1. Separate the communications cables from the main circuit cables and other wiring and power cables.
2. Use shielded cables for the communications cables, and use proper shield clamps
3. When using RS-485 communications, connect S+ to R+, and S- to R-, on the Inverter exterior. See picture below.



■ Procedure for Communicating with the PLC

Use the following procedure to perform communications with the PLC.

1. Turn OFF the power supply and connect the communications cable between the PLC and the Inverter.
2. Turn ON the power supply.
3. Set the required communications parameters (H5-01 to H5-07) using the Digital Operator.
4. Turn OFF the power supply, and check that the Digital Operator display has completely disappeared.
5. Turn ON the power supply once again.
6. Perform communications with the PLC.

■ Related Parameters

Parameter No.	Name	Factory Setting	Change during Operation	Control Methods			
				V/f	V/f with PG	Open Loop Vector	Closed Loop Vector
b1-01	Reference source selection	1	No	Q	Q	Q	Q
b1-02	RUN command Source Selection	1	No	Q	Q	Q	Q
H5-01	Station address	1F *	No	A	A	A	A
H5-02	Baud rate selection	3	No	A	A	A	A
H5-03	Communications parity selection	0	No	A	A	A	A
H5-04	Communications error detection selection	3	No	A	A	A	A
H5-05	Communications error detection selection	1	No	A	A	A	A
H5-06	Send wait time	5 ms	No	A	A	A	A
H5-07	RTS control ON/OFF	1	No	A	A	A	A

* Set H5-01 to 0 to disable Inverter responses to MEMOBUS communications.

MEMOBUS communications can perform the following operations regardless of the settings in b1-01 and b1-02.

- Monitoring operation status of the inverter
- Setting and reading parameters
- Resetting errors
- Inputting multi-function commands. (An OR operation is performed between the multi-function commands input from the PLC and commands input from digital input terminals S3 to S7.)

■ Message Format

In MEMOBUS communications, the master sends commands to the slave, and the slave responds. The message format is configured for both sending and receiving as shown below, and the length of data packets depends on the command (function) content.

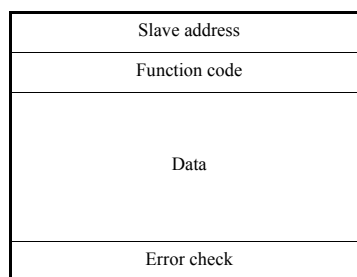

The space between messages must meet the following conditions:

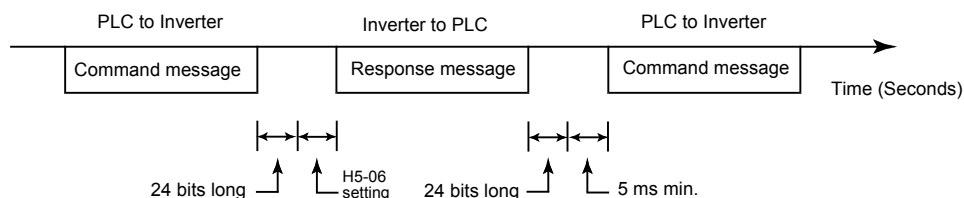

Fig 6.76 Message Spacing

Slave Address

Set the Inverter address from 0 to 31. If you set 0, commands from the master will be received by all slaves. (Refer to “Broadcast Data” on the following pages.)

Function Code

The function code specifies commands. The three function codes shown in the table below are available.

Function Code (Hexadecimal)	Function	Command Message		Response Message	
		Min. (Bytes)	Max. (Bytes)	Min. (Bytes)	Max. (Bytes)
03H	Read memory register contents	8	8	7	37
08H	Loop back test	8	8	8	8
10H	Write multiple memory registers	11	41	8	8

Data

Configure consecutive data by combining the memory register address (test code for a loop back address) and the data the register contains. The data length changes depending on the command details.

Error Check

Errors during communications are detected using CRC-16 (cyclic redundancy check, checksum method).

The result of the checksum calculation is stored in a data-word (16 bit), which starting value is FFFH. The value of this word is manipulated using Exclusive OR- and SHIFT operations together with the data package that should be sent (slave address, function code, data) and the fixed value A001H. At the end of the calculation the data-word contains the checksum value.

The checksum is calculated in the following way:

1. The starting value of the 16 Bit data-word, that is used for the calculation, has to be set to FFFFH.
2. An Exclusive OR operation has to be performed with the starting value and the slave address.
3. The result has to be shifted to the right until the overflow bit becomes 1.
4. When this bit becomes 1, an Exclusive OR operation with the result of step 3 and the fix value A001H has to be performed.
5. After 8 shift operations (every time when the overflow bit becomes 1, an Exclusive OR like in step 4 has to be done), perform an Exclusive OR operation with the result of the former operations and the next data package (8 bit function code). Again the result of this operation has to be shifted 8 times and if needed it has to be interconnected with the fix value A001H using an Exclusive OR operation.
6. The same steps have to be performed with the data, first with the higher byte and then with the lower byte until all data are proceeded.
7. The result of these operations is the checksum. It consists of a high and a low byte.

The following example clarifies the calculation method. It shows the calculation of a CRC-16 code with the slave address 02H (0000 0010) and the function code 03H (0000 0011). The resulting CRC-16 code is D1H for the lower and 40H for the higher byte. The example calculation in this example is not done completely (normally data would follow the function code).

Calculations	Overflow	Description
1111 1111 1111 1111		Initial value
0000 0010		Address
1111 1111 1111 1101		ExOr Result
0111 1111 1111 1110	1	Shift 1
1010 0000 0000 0001		
1101 1111 1111 1111		ExOr Result
0110 1111 1111 1111	1	Shift 2
1010 0000 0000 0001		
1100 1111 1111 1110		ExOr Result
0110 0111 1111 1111	0	Shift 3
0011 0011 1111 1111	1	Shift 4
1010 0000 0000 0001		
1001 0011 1111 1110		ExOr Result
0100 1001 1111 1111	0	Shift 5
0010 0100 1111 1111	1	Shift 6
1010 0000 0000 0001		
1000 0100 1111 1110		ExOr Result
0100 0010 0111 1111	0	Shift 7
0010 0001 0011 1111	1	Shift 8
1010 0000 0000 0001		
1000 0001 0011 1110		ExOr Result
0000 0011		Function Code
1000 0001 0011 1101		ExOr Result
0100 0000 1001 1110	1	Shift 1
1010 0000 0000 0001		
1110 0000 1001 1111		ExOr Result
0111 0000 0100 1111	1	Shift 2
1010 0000 0000 0001		
1101 0000 0100 1110		ExOr Result
0110 1000 0010 0111	0	Shift 3
0011 0100 0001 0011	1	Shift 4
1010 0000 0000 0001		
1001 0100 0001 0010		ExOr Result
0100 1010 0000 1001	0	Shift 5
0010 0101 0000 0100	1	Shift 6
1010 0000 0000 0001		
1000 0101 0000 0101		ExOr Result
0100 0010 1000 0010	1	Shift 7
1010 0000 0000 0001		
1110 0010 1000 0011		ExOr Result
0111 0001 0100 0001	1	Shift 8
1010 0000 0000 0001		
1101 0001 0100 0000		ExOr Result
D1H 40H		CRC-16 Result
Higher Lower		
Byte Byte		

MEMOBUS Message Example

An example of MEMOBUS command/response messages is given below.

Reading Inverter Memory Register Contents

The content of maximum 16 inverter memory registers can be readout at a time.

Among other things the command message must contain the start address of the first register that is to be read out and the quantity of registers that should be read out. The response message will contain the content of the first and the consecutive number of registers that has been set for the quantity.

The contents of the memory register are separated into higher 8 bits and lower 8 bits.

The following tables show message examples when reading status signals, error details, data link status, and frequency references from the slave 2 Inverter.

Command Message			Response Message (During Normal Operation)			Response Message (During Error)		
Slave Address	02H		Slave Address	02H		Slave Address	02H	
Function Code	03H		Function Code	03H		Function Code	83H	
Start Address	Higher	00H	Data quantity	08H		Error code	03H	
	Lower	20H	1st storage register	Higher	00H	CRC-16	Higher	F1H
Quantity	Higher	00H		Lower	65H		Lower	31H
	CRC-16	Higher	45H	Next storage register	Higher	00H		
Lower		F0H	Lower		00H			
			Next storage register	Higher	00H			
				Lower	00H			
			Next storage register	Higher	01H			
				Lower	F4H			
			CRC-16	Higher	AFH			
				Lower	82H			

Loop back Test

The loop back test returns command messages directly as response messages without changing the contents to check the communications between the master and slave. You can set user-defined test code and data values.

The following table shows a message example when performing a loop back test with the slave no. 1.

Command Message			Response Message (During Normal Operation)			Response Message (During Error)		
Slave address	01H		Slave address	01H		Slave address	01H	
Function code	08H		Function code	08H		Function code	89H	
Test Code	Higher	00H	Test Code	Higher	00H	Error Code	01H	
	Lower	00H		Lower	00H	CRC-16	Higher	86H
Data	Higher	A5H	Data	Higher	A5H		Lower	50H
	Lower	37H		Lower	37H			
CRC-16	Higher	DAH	CRC-16	Higher	DAH			
	Lower	8DH		Lower	8DH			

Writing to Multiple Inverter Memory Registers

The writing of inverter memory registers works similar to the reading process, i.e. the address of the first register that is to be written and the quantity of to be written registers must be set in the command message.

The to be written data must be consecutive, starting from the specified address in the command message. The data order must be higher 8 bits, then lower 8 bits. The data must be in memory register address order.

The following table shows an example of a message where a forward operation has been set with a frequency reference of 60.0 Hz for the inverter with the slave address 01H.

Command Message			Response Message (During Normal Operation)			Response Message (During Error)		
Slave Address		01H	Slave Address		01H	Slave Address		01H
Function Code		10H	Function Code		10H	Function Code		90H
Start Address	Higher	00H	Start Address	Higher	00H	Error code		02H
	Lower	01H		Lower	Lower	01H	CRC-16	Higher
Quantity	Higher	00H	Quantity		Higher	00H		Lower
	Lower	02H		Lower	Lower	02H	CRC-16	
No. of data		04H	CRC-16		Higher	10H		
Lead data	Higher	00H	Lower		Lower	08H		
	Lower	01H						
Next data	Higher	02H						
	Lower	58H						
CRC-16	Higher	63H						
	Lower	39H						

* No. of data = 2 x (quantity)



For the number of data value in the command message the double value of the data quantity must be taken.

■ Data Tables

The data tables are shown below. The types of data are as follows: Reference data, monitor data, and broadcast data.

Reference Data

The reference data table is shown below. These data can be read and written. They cannot be used for monitoring functions.

Register Address	Contents	
0000H	Reserved	
0001H	Run operation and input commands	
	Bit 0	Forward run
	Bit 1	Reverse run
	Bit 2	External error
	Bit 3	Reset command
	Bit 4	ComNet
	Bit 5	ComCtrl
	Bit 6	Multi-function input command 3
	Bit 7	Multi-function input command 4
	Bit 8	Multi-function input command 5
	Bit 9	Multi-function input command 6
	Bit A	Multi-function input command 7
	Bits B to F	Not used
0002H	Frequency reference (Set units using parameter o1-03)	
0003H to 0005H	Not used	
0006H	PID target value	
0007H	Analog output 1 setting (-11 V/-726 to 11 V/726) → 10V = 660	
0008H	Analog output 2 setting (-11 V/-726 to 11 V/726) → 10V = 660	
0009H	Multi-function contact output setting	
	Bit 0	Contact output 1 (Terminal M1-M2) 1: ON 0: OFF
	Bit 1	Contact output 2 (Terminal M3-M4) 1: ON 0: OFF
	Bit 2	Contact output 3 (Terminal M5-M6) 1: ON 0: OFF
	Bits 3 to 5	Not used
	Bit 6	Enables/Disables error contact (terminal MA-MC) setting using bit 7 1: ON 0: OFF
	Bit 7	Error contact (terminal MA-MC) 1: ON 0: OFF
	Bits 8 to F	Not used
000AH to 000EH	Not used	
000FH	Reference selection settings	
	Bit 0	Not used
	Bit 1	Input PID target value 1: Enabled 0: Disabled
	Bits 3 to B	Not used
	C	Broadcast data terminal S5 input 1: Enabled 0: Disabled
	D	Broadcast data terminal S6 input 1: Enabled 0: Disabled
	E	Broadcast data terminal S7 input 1: Enabled 0: Disabled
	F	Not used

Note: Write 0 to all unused bits. Also, do not write data to reserved registers.

Monitor Data

The following table shows the monitor data. Monitor data can only be read.

Register Address.	Contents	
0010H	Inverter status signal	
	Bit 0	During run
	Bit 1	Zero speed
	Bit 2	During reverse operation
	Bit 3	Reset signal active
	Bit 4	During speed agree
	Bit 5	Inverter ready
	Bit 6	Minor fault
	Bit 7	Major fault
	Bits 8 to F	Not used
0011H	Operator status	
	Bit 0	During OPE alarm
	Bit 1	During fault
	Bit 2	Operator in programming mode
	Bit 3, 4	00: JVOP-160 attached, 01: JVOP-161 attached, 11: PC connected
	Bit 5 to F	Not used
0012H	OPE Fault Number	
0013H	Not used	
0014H	Fault Content 1	
	Bit 0	PUF, DC bus fuse blown
	Bit 1	UV1
	Bit 2	UV2
	Bit 3	UV3
	Bit 4	Not used
	Bit 5	GF, Ground fault
	Bit 6	OC, Over current
	Bit 7	OV, DC bus over voltage
	Bit 8	OH, Inverter heatsink overheat pre-alarm
	Bit 9	OH1, Inverter heatsink overheat
	Bit A	OL1, Motor overload
	Bit B	OL2, Inverter overload
	Bit C	OL3, Overtorque detection 1
	Bit D	OL4, Overtorque detection 2
Bit E	RR, Internal braking transistor fault	
Bit F	RH, Inverter mounted braking resistor overheat	
0015H	Fault Content 2	
	Bit 0	EF3, External fault set on terminal S3
	Bit 1	EF4, External fault set on terminal S4
	Bit 2	EF5, External fault set on terminal S5
	Bit 3	EF6, External fault set on terminal S6
	Bit 4	EF7, External fault set on terminal S7
	Bit 5	Not used
	Bit 6	Not used
	Bit 7	OS, Overspeed detected
	Bit 8	DEV, Speed deviation detected
	Bit 9	PGO, PG disconnected
	Bit A	PF, Input phase loss
	Bit B	LF, Output open phase
Bit C	OH3, Motor overheat pre-alarm (PTC analog input)	
Bit D	OPR, Digital operator disconnected	

Register Address.	Contents	
0015H	Bit E	ERR,
	Bit F	OH4, Motor overheat (PTC analog input)
0016H	Fault Content 3	
	Bit 0	CE, Memobus communications error
	Bit 1	BUS, Bus option communications error
	Bit 2/3	Not used
	Bit 4	CF, Control fault
	Bit 5	Not used
	Bit 6	EF0, External fault from optional input card
	Bit 7	FBL, PID feedback loss
	Bit 8	UL3, Undertorque detection 1
	Bit 9	UL4, Undertorque detection 2
	Bit A	OL7, High Slip Braking overload
	Bit B to F	Not used
0017H	CPF Fault Content 1	
	Bit 0/1	Not used
	Bit 2	CPF02
	Bit 3	CPF03
	Bit 4	Not used
	Bit 5	CPF05
	Bit 6	CPF06
Bit 7 to F	Not used	
0018H	CPF Fault Content 2	
	Bit 0	CPF20
	Bit 1	CPF21
	Bit 2	CPF22
	Bit 3	CPF23
Bit 4 to F	Not used	
0019H	Alarm Content 1	
	Bit 0	UV, DC bus undervoltage
	Bit 1	OV, DC bus overvoltage
	Bit 2	OH, Inverter heatsink overheat pre-alarm
	Bit 3	OH2, Inverter overheat alarm input by a digital input
	Bit 4	OL3, Overtorque detection 1
	Bit 5	OL4, Overtorque detection 2
	Bit 6	EF, Forward/Reverse input set at the same time
	Bit 7	BB, Baseblock active
	Bit 8	EF3, External alarm set on terminal S3
	Bit 9	EF4, External alarm set on terminal S4
	Bit A	EF5, External alarm set on terminal S5
	Bit B	EF6, External alarm set on terminal S6
	Bit C	EF7, External alarm set on terminal S7
Bit D/E	Not used	
Bit F	OS, Overspeed alarm	
001AH	Alarm Content 2	
	Bit 0	Not used
	Bit 1	DEV, Speed deviation
	Bit 2	PGO, PG disconnected
	Bit 3	OPR, Digital operator disconnected
	Bit 4	CE, Memobus communications error
	Bit 5	CALL, Communications on standby
	Bit 6	OL1, Motor overload
Bit 7	OL2, Inverter overload	

Register Address.	Contents	
001AH	Bit 8 to A	Not used
	Bit B	FBL, PID feedback loss
	Bit C	CALL, Communications on standby
	Bit D	UL3, Undertorque detection 1
	Bit E	UL4, Undertorque detection 2
	Bit F	Not used
001BH	Alarm Content 3	
	Bit 0	Not used
	Bit 1	OH3, Motor overheat pre-alarm
	Bit 2 to F	Not used
0020H	Inverter status	
	Bit 0	Forward operation
	Bit 1	Reverse operation
	Bit 2	Inverter startup complete 1: Completed 2: Not completed
	Bit 3	Error
	Bit 4	Data setting error
	Bit 5	Multi-function contact output 1 (terminal M1 - M2) 1: ON 0: OFF
	Bit 6	Multi-function contact output 2 (terminal M3 - M4) 1: ON 0: OFF
	Bit 7	Multi-function contact output 3 (terminal M5 - M6) 1: ON 0: OFF
Bits 8 to F	Not used	
0021H	Error details	
	Bit 0	Overcurrent (OC), Ground fault (GF)
	Bit 1	Main circuit overvoltage (OV)
	Bit 2	Inverter overload (OL2)
	Bit 3	Inverter overheat (OH1, OH2)
	Bit 4	Braking transistor/resistance overheat (tr, rH)
	Bit 5	Fuse blown (PUF)
	Bit 6	PID feedback lost (FbL)
	Bit 7	External error (EF, EFO)
	Bit 8	Control board error (CPF)
	Bit 9	Motor overload (OL1) or overtorque 1 (OL3) detected
	Bit A	PG broken wire detected (PGO), Overspeed (OS), Speed deviation (DEV)
	Bit B	Main circuit undervoltage (UV) detected
	Bit C	Main circuit undervoltage (UV1), control power supply error (UV2), inrush prevention circuit error (UV3), power loss
	Bit D	Missing output phase (LF)
Bit E	MEMOBUS communications error (CE)	
Bit F	Operator disconnected (OPR)	
0022H	Data link status	
	Bit 0	Writing data
	Bit 1	Not used
	Bit 2	Not used
	Bit 3	Upper and lower limit errors
	Bit 4	Data integrity error
	Bits 5 to F	Not used
0023H	Frequency reference	Monitors U1-01
0024H	Output frequency	Monitors U1-02
0025H	Output voltage (U1-06)	
0026H	Output current	U1-03
0027H	Output power	U1-08
0028H	Torque reference	U1-09
0029H	Not used	
002AH	Not used	

Register Address.	Contents	
002BH	Control terminals input status	
	Bit 0	Input terminal S1 1: ON 0: OFF
	Bit 1	Input terminal S2 1: ON 0: OFF
	Bit 2	Multi-function input terminal S3 1: ON 0: OFF
	Bit 3	Multi-function input terminal S4 1: ON 0: OFF
	Bit 4	Multi-function input terminal S5 1: ON 0: OFF
	Bit 5	Multi-function input terminal S6 1: ON 0: OFF
	Bit 6	Multi-function input terminal S7 1: ON 0: OFF
	Bits 7 to F	Not used
002CH	Inverter status	
	Bit 0	Operation 1: Operating
	Bit 1	Zero speed 1: Zero speed
	Bit 2	Frequency agree 1: Agreement
	Bit 3	User-defined speed agree 1: Agreement
	Bit 4	Frequency detection 1 1: Output frequency \leq L4-01
	Bit 5	Frequency detection 2 1: Output frequency \geq L4-01
	Bit 6	Inverter startup completed 1: Startup completed
	Bit 7	Undervoltage detection 1: Detected
	Bit 8	Baseblock 1: Inverter output baseblock
	Bit 9	Frequency reference mode 1: Not communication 0: Communication option
	Bit A	Run command mode 1: Not communication 0: Communication option
	Bit B	Overtorque detection 1: Detected
	Bit C	Frequency reference lost 1: Lost
	Bit D	Restart enabled1: Restarting
	Bit E	Error (including MEMOBUS communications time-out) 1: Error occurred
Bit F	MEMOBUS communications time-out 1: Timed out	
002DH	Multi-function contact output status	
	Bit 0	Multi-function contact output 1 (terminal M1-M2) 1: ON 0: OFF
	Bit 1	Multi-function contact output 2 (terminal M3-M4) 1: ON 0: OFF
	Bit 2	Multi-function contact output 3 (terminal M5-M6) 1: ON 0: OFF
		Bits 3 to F
002EH - 0030H	Not used	
0031H	Main circuit DC voltage	
0032H - 0037H	Not used	
0038H	PID feedback (max. output frequency = 100%; resolution 0.1%; without sign)	
0039H	PID input (max. output frequency = 100%; resolution 0.1%; with sign)	
003AH	PID output (max. output frequency = 100%; resolution 0.1%; with sign)	
003BH	CPU software number	
003CH	Flash software number	
003DH	Communications error details	
	Bit 0	CRC error
	Bit 1	Invalid data length
	Bit 2	Not used
	Bit 3	Parity error
	Bit 4	Overrun error
	Bit 5	Framing error
	Bit 6	Time-out
	Bits 7 to F	Not used
003EH	kVA setting	
003FH	Control method	

Note: Communications error details are stored until an error reset is input (you can also reset while the Unit is operating).

Broadcast Data

Using broadcast data a command can be given to all slaves at the same time. The slave address in the command message must be set to 00H. All slaves will receive the message. They will not respond.

The following table shows the broadcast data. You can also write this data.

Register Address	Contents	
0001H	Operation signal	
	Bit 0	Forward run
	Bit 1	Reverse run
	Bits 2 and 3	Not used
	Bit 4	External error 1
	Bit 5	Error reset 1
	Bits 6 to B	Not used
	Bit C *1	Multi-function digital input terminal S5 input
	Bit D *1	Multi-function digital input terminal S6 input
	Bit E *1	Multi-function digital input terminal S7 input
	Bit F	Not used.
0002H	Frequency reference	

Note: Bit signals not defined in the broadcast operation signals use the local inverter input/output signals.

* A change of these bits to 1 will be accepted only, if the bits C,D and/or E in register 000FH (reference data) are set to 1 at the inverter, at which the inputs S5, S6 and S7 shall be enabled.

■ Inverter Error Codes

The content of a current fault and faults that have occurred earlier can be read out by Memobus using the Fault Trace (U2-□□) and the Fault History (U3-□□) parameters. The fault codes are shown in the table below.

Fault Code	Fault Description	Fault Code	Fault Description	Fault Code	Fault Description
01H	PUF	13H	EF5	28H	FBL
02H	UV1	14H	EF6	29H	UL3
03H	UV2	15H	EF7	2AH	UL4
04H	UV3	18H	OS	2BH	OL7
06H	GF	19H	DEV	83H	CPF02
07H	OC	1AH	PGO	84H	CPF03
08H	OV	1BH	PF	85H	CPF04
09H	OH	1CH	LF	86H	CPF05
0AH	OH1	1DH	OH3	87H	CPF06
0BH	OL1	1EH	OPR	88H	CPF07
0CH	OL2	1FH	ERR	89H	CPF08
0DH	OL3	20H	OH4	8AH	CPF09
0EH	OL4	21H	CE	8BH	CPF10
0FH	RR	22H	BUS	91H	CPF20
10H	RH	25H	CF	92H	CPF21
11H	EF3	26H	SVE	93H	CPF22
12H	EF4	27H	EF0	94H	CPF23

Refer to [page 7-2, Fault Detection](#) for detailed fault descriptions and for corrective actions.

■ ENTER Command

When writing parameters to the Inverter from the PLC using MEMOBUS communications, the parameters are temporarily stored in the parameter data area of the Inverter. To enable these parameters in the parameter data area the ENTER command must be used.

There are two types of ENTER commands:

- ENTER commands that enable parameter data in RAM only (changes will be lost after power loss)
- ENTER commands that write data into the EEPROM (non-volatile memory) of the Inverter and enable the data in RAM at the same time.

The following table shows the ENTER command data. ENTER command data can only be written.

The ENTER command is enabled by writing 0 to register number 0900H or 0910H.

Register Address.	Contents
0900H	Write parameter data to EEPROM, RAM is refreshed
0910H	Parameter data are not written to EEPROM, but refreshed in RAM only.



INFO

- The maximum number of times you can write to EEPROM is 100,000. Do not frequently execute ENTER commands (0900H) that write into EEPROM.
- The ENTER command registers are write-only. Consequently, if these registers should be read out, the register address will become invalid (Error code: 02H).
- An ENTER command is not required if reference or broadcast data are sent to the inverter.

■ Error Codes

The following table shows MEMOBUS communications error codes.

Error Code	Contents
01H	Function code error A function code other than 03H, 08H, or 10H has been set by the PLC.
02H	Invalid register number error <ul style="list-style-type: none"> • The register address you are attempting to access is not recorded anywhere. • With broadcast sending, a start address other than 0001H, or 0002H has been set.
03H	Invalid quantity error <ul style="list-style-type: none"> • The number of data packets (register content) being read or written is outside the range of 1 to 16. • In write mode, the number of data bytes in the message is not No. of packets x 2.
21H	Data setting error <ul style="list-style-type: none"> • A simple upper limit or lower limit error has occurred in the control data or when writing parameters. • When writing parameters, the parameter setting is invalid.
22H	Write mode error <ul style="list-style-type: none"> • Attempting to write parameters to the inverter during operation. • Attempting to write via ENTER commands during operation. • Attempting to write parameters other than A1-00 to A1-05, E1-03, or 02-04 when warning alarm CPF03 (defective EEPROM) has occurred. • Attempting to write read-only data.
23H	Writing during DC bus undervoltage (UV) error <ul style="list-style-type: none"> • Writing parameters to the inverter during UV (DC bus undervoltage) alarm. • Writing via ENTER commands during UV (DC bus undervoltage) alarm.
24H	Writing error during parameters processing Attempting to write parameters while processing parameters in the Inverter.

■ Slave Not Responding

In the following cases, the slave will ignore the write function.

- When a communications error (overrun, framing, parity, or CRC-16) is detected in the command message.
- When the slave address in the command message and the slave address in the Inverter do not agree.
- When the gap between two blocks (8 bit) of a message exceeds 24 bits.
- When the command message data length is invalid.



INFO

If the slave address specified in the command message is 0, all slaves execute the write function, but do not return response messages to the master.

■ Self-Diagnosis

The Inverter has a built-in function for self-diagnosing the serial communication interface circuits. This function is called the self-diagnosis function. It uses the connected communications parts of the send and receive terminals to receive data sent by the Inverter and thereby to check if communication is performed normally.

To perform the self-diagnosis function use the following procedure.

1. Turn ON the inverter power supply, and set 67 (communications test mode) in parameter H1-05 (Terminal S7 Function Selection).
2. Turn OFF the inverter power supply.
3. Perform the wiring according to [Fig 6.77](#).
4. Turn ON the terminating resistance. (Turn ON pin 1 on DIP switch 1.)
5. Turn ON the inverter power supply.

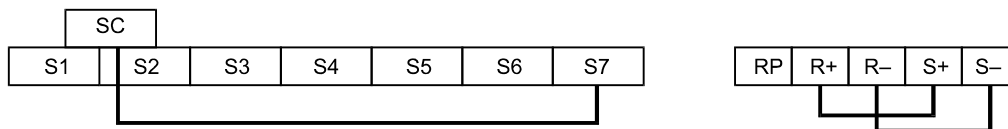

Fig 6.77 Communication Terminals Wiring for Self-Diagnosis

During normal operation, the Digital Operator displays “PASS” on the display.

If an error occurs, a “CE” (MEMOBUS communications error) alarm will be displayed on the Digital Operator, the error contact output will be turned ON, and the Inverter operation ready signal will be turned OFF.

◆ Using the Timer Function

The multi-function digital input terminals S3 to S7 can be used as timer function input terminals, and multi-function output terminals M1-M2, M3-M4, and M5-M6 can be used as timer function output terminals. By setting the delay time, you can prevent chattering of the sensors and switches.

- Set one of the parameters H1-01 to H1-05 (digital input terminal S3 to S7) to 18 (timer function input).
- Set H2-01 to H2-03 (multi-function output terminals M1-M2, M3-M4, and M5-M6 function selection) to 12 (timer function output).

■ Related Parameters

Parameter No.	Name	Factory Setting	Change during Operation	Control Methods			
				V/f	V/f with PG	Open Loop Vector	Closed Loop Vector
b4-01	Timer function ON-delay time	0.0 s	No	A	A	A	A
b4-02	Timer function OFF-delay time	0.0 s	No	A	A	A	A

Multi-function Digital Inputs (H1-01 to H1-05)

Set Value	Function	Control Methods			
		V/f	V/f with PG	Open Loop Vector	Closed Loop Vector
18	Timer function input	Yes	Yes	Yes	Yes

Multifunction Outputs (H2-01 to H2-03)

Set Value	Function	Control Methods			
		V/f	V/f with PG	Open Loop Vector	Closed Loop Vector
12	Timer function output	Yes	Yes	Yes	Yes

■ Setting Example

When the timer function input ON time is longer than the value set in b4-01, the timer output function is turned ON. When the timer function input OFF time is longer than the value set in b4-02, the timer output function is turned OFF. An example of timer function operation is given in the following diagram.

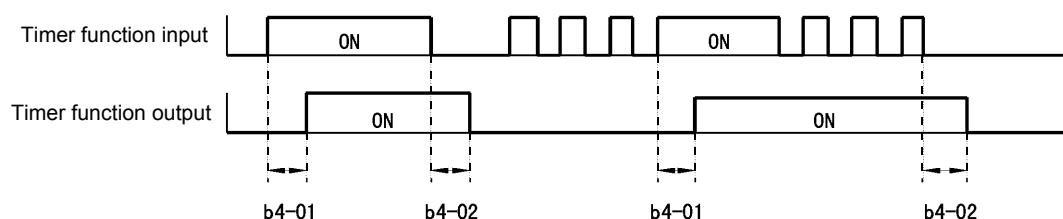

Fig 6.78 Timer Function Operation Example

◆ Using PID Control

PID control is a method of making the feedback value (detection value) matching the set target value. By combining proportional control (P), integral control (I), and differential control (D), you can even control system with load fluctuation.

The characteristics of the PID control operations are given below.

P element	The output of a P-element is proportional to the input (deviation). With using a P-element alone it is not possible to eliminate the deviation completely.
I element	The output of an I-element is the time-integral of the input (deviation). With using a P-element and an I-element together the deviation can be eliminated completely.
D element	The output of a D-element is the derivative of the input (deviation). By adding a D-element the response can be improved rapidly but the system can also become unstable.

■PID Control Operation

To understand the differences between the PID control operations P, I, and D, the output share of each operation is shown in the following diagram when the deviation (i.e., the difference between the target value and feedback value) is fixed.

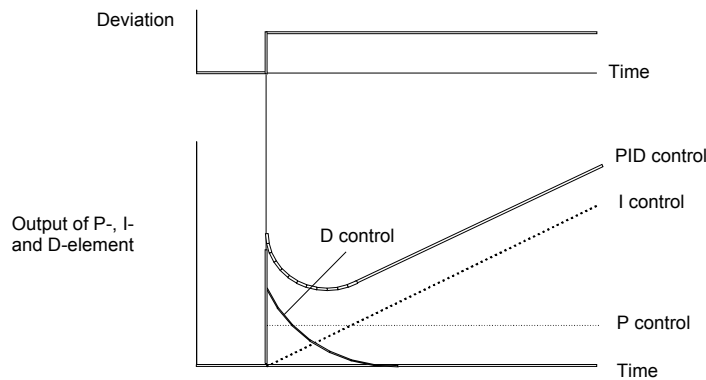

Fig 6.79 PID Control Operation

■PID Control Applications

The following table shows examples of PID control applications using the Inverter.

Application	Control Details	Example of Sensor Used
Speed Control	<ul style="list-style-type: none"> Machinery speed is fed back and adjusted to meet the target value. Speed informations from other machinery can be input as the target value and synchronous control using the actual speed feedback can be performed. 	Tachometer generator
Pressure Control	Pressure information is fed back and constant pressure control is performed.	Pressure sensor
Flow Rate Control	Flow rate information is fed back and the flow rate is controlled with high accuracy.	Flow rate sensor
Temperature Control	Temperature information is fed back and a temperature adjustment control using a fan can be performed.	<ul style="list-style-type: none"> Thermocoupler Thermistor

■Related Parameters

Parameter No.	Name	Factory Setting	Change during Operation	Control Methods			
				V/f	V/f with PG	Open Loop Vector	Closed Loop Vector
b5-01	PID control mode selection	0	No	A	A	A	A
b5-02	Proportional gain (P)	1.00	Yes	A	A	A	A
b5-03	Integral (I) time	1.0 s	Yes	A	A	A	A
b5-04	Integral (I) limit	100.0%	Yes	A	A	A	A
b5-05	Differential (D) time	0.00 s	Yes	A	A	A	A
b5-06	PID limit	100.0%	Yes	A	A	A	A
b5-07	PID offset adjustment	0.0%	Yes	A	A	A	A
b5-08	PID delay time constant	0.00 s	Yes	A	A	A	A
b5-09	PID output characteristics selection	0	No	A	A	A	A
b5-10	PID output gain	1.0	No	A	A	A	A
b5-11	PID reverse output selection	0	No	A	A	A	A
b5-12	Selection of PID feedback loss detection	0	No	A	A	A	A
b5-13	PID feedback loss detection level	0%	No	A	A	A	A
b5-14	PID feedback loss detection time	1.0 s	No	A	A	A	A
b5-15	PID sleep function operation level	0.0 Hz	No	A	A	A	A
b5-16	PID sleep operation delay time	0.0 s	No	A	A	A	A
b5-17	Accel/decel time for PID reference	0.0 s	No	A	A	A	A
b5-18	PID Setpoint Selection	0	No	A	A	A	A
b5-19	PID set point	0	No	A	A	A	A
b5-28	PID square root feedback selection	0	No	A	A	A	A
b5-29	Square root feedback gain	1.00	No	A	A	A	A
b5-31	PID monitor feedback selection	0	No	A	A	A	A
b5-32	PID monitor feedback gain	100.0%	No	A	A	A	A
b5-33	PID monitor feedback bias	0.0%	No	A	A	A	A

Monitor Items (U1-□□)

Parameter Number	Name	Output Signal Level During Multi-Function Analog Output	Min. Unit	Control Methods			
				V/f	V/f with PG	Open Loop Vector	Closed Loop Vector
U1-24	PID feedback value	10 V: 100% feedback	0.01%	A	A	A	A
U1-36	PID input volume	10 V: 100% PID input	0.01%	A	A	A	A
U1-37	PID output volume	10 V: 100% PID output	0.01%	A	A	A	A
U1-38	PID set point	10 V: 100% PID target	0.01%	A	A	A	A

Multi-Function Digital Inputs (H1-01 to H1-05)

Set Value	Function	Control Methods			
		V/f	V/f with PG	Open loop Vector	Closed Loop Vector
19	PID control disable (ON: PID control disabled)	Yes	Yes	Yes	Yes
30	PID control integral reset (reset when reset command is input or when stopped during PID control)	Yes	Yes	Yes	Yes
31	PID control integral hold (ON: Integral hold)	Yes	Yes	Yes	Yes
34	PID soft starter	Yes	Yes	Yes	Yes
35	PID input characteristics switch	Yes	Yes	Yes	Yes

Multi-Function Analog Input (H3-09)

Set Value	Function	Control Methods			
		V/f	V/f with PG	Open loop Vector	Closed Loop Vector
B	PID feedback	Yes	Yes	Yes	Yes
C	PID target value	Yes	Yes	Yes	Yes

Pulse Train Input (H6-01)

Set Value	Function	Control Methods			
		V/f	V/f with PG	Open loop Vector	Closed Loop Vector
0	Frequency reference	Yes	Yes	Yes	Yes
1	PID feedback value	Yes	Yes	Yes	Yes
2	PID target value	Yes	Yes	Yes	Yes

■PID Control Methods (b5-01)

There are four PID control methods. Select the method by setting parameter b5-01.

Set Value	Control Method
1	PID output becomes the Inverter output frequency, and D control is used in the deviation (difference between PID target value and feedback value.)
2	PID output becomes the Inverter output frequency, and D control is used in the PID feedback value.
3	PID output is added as compensation value of the Inverter output frequency, and D control is used in the deviation (difference between PID target value and feedback value).
4	PID output is added as compensation value of the Inverter output frequency, and D control is used in the PID feedback value.

■ PID Input Methods

PID Target Value Input Sources

Normally, the frequency reference source selected in b1-01 is the PID target value source. Alternatively the PID target value can be set as shown in the following table.

PID Target Input Method	Setting Conditions
Multi-Function Analog Terminal A2 Input	Set H3-09 to C (PID target value). Either the pulse train input or the analog input A1 can be selected as PID feedback value.
MEMOBUS register 0006H	Set MEMOBUS bit 1 in register address 000FH to 1 (enable/disable PID target value from communications) to be able to use register number 0006H as the PID target value.
Pulse train input	Set H6-01 to 2 (PID target value).
Parameter setting	If b5-18 is set to 1 the value in b5-19 becomes the PID target value.



INFO

If the PID function is used, the frequency reference value becomes the target value, which is set and shown in Hz on the operator. Nevertheless, internally the PID target value is used in percent. I.e. the following formula is used:

$$\text{PID target value [\%]} = \frac{\text{frequency reference [Hz]}}{\text{max. output frequency [Hz]}} \cdot 100\%$$

PID Feedback Input Methods

Select one of the following PID control feedback input methods

Input Method	Setting Conditions
Multi-function analog input	Set H3-09 (Multi-function Analog Input Terminal A2 Selection) to B (PID feedback).
Pulse train input	Set H6-01 to 1 (PID feedback).
Monitor Parameter	Set the number of the monitor parameter U1-□□, which shall be the PID feedback, in parameter b5-31



INFO

Adjust PID target value and PID feedback value using the following items.

- Analog input: Adjust using the analog input terminal gain and bias.
- Pulse train input: Adjust using pulse train scaling, pulse train input gain, and pulse train input bias.

■ PID Adjustment Examples

Suppressing Overshoot

If overshoot occurs, reduce Proportional gain (P), and increase integral time (I).

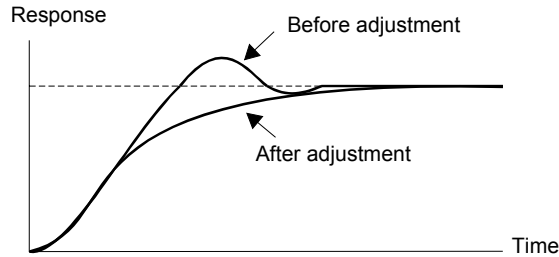

Set a Rapidly Stabilizing Control Condition

To rapidly stabilize the control even if overshoot occurs, reduce integral time (I), and lengthen differential time (D).

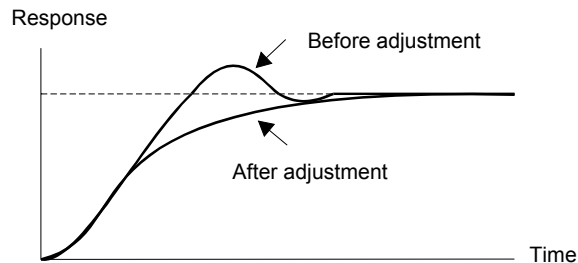

Suppressing Long-cycle Vibration

If vibration occurs with a longer cycle than the integral time (I) set value, lengthen the integral time (I) to suppress the vibration.

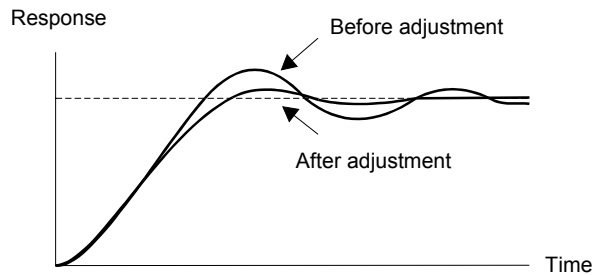

Suppressing Short Cycle Vibration

If vibration occurs when the vibration cycle duration is short, and the cycle duration is almost identical to the differential time (D) set value, the differential operation is too strong. Shorten the differential time (D) to suppress the vibration.

If vibration continues even when the differential time (D) is set to 0.00 (D control disabled), reduce the proportional gain (P), or increase the PID primary delay time constant.

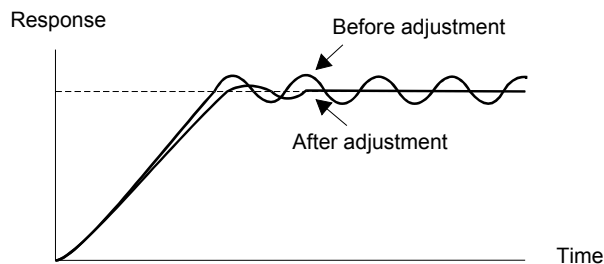

■ Setting Precautions

- In PID control, the b5-04 parameter is used to prevent the calculated integral control value from exceeding a specified amount. When the load varies rapidly, the Inverter response is delayed, and the machine might get damaged or the motor may stall. In this case, reduce the set value to speed up Inverter response.
- The b5-06 parameter is used to prevent the output value of the PID control calculation from exceeding a specified amount. The value is set taking the maximum output frequency as 100%.
- The b5-07 parameter is used to adjust PID control offset. The value is set in increments of 0.1%, taking the maximum output frequency to be 100%.
- Set the filter time constant for the PID control output in b5-08. Enable this parameter to prevent machinery resonance when machinery friction is high, or rigidity is poor. In this case, set the parameter to be higher than the resonance frequency cycle duration. Increase this time constant to reduce Inverter responsiveness.
- Using b5-09, the PID output polarity can be inverted. If now the PID feedback value increases the output frequency will be increased. This function is usable e.g. for vacuum pumps.
- Using b5-10, you can apply a gain to the PID control output. Enable this parameter to adjust the amount of compensation if adding PID control output to the frequency reference as compensation (b5-01 = 3/4).
- When PID control output is negative, you can use parameter b5-11 to determine what happens to the inverter output. When b1-04 (Prohibition of Reverse Operation) is set to 1 (enabled), however, the PID output is limited to 0.
- Using the b5-17 parameter the PID target value can be raised or lowered with an accel./decel. ramp function (PID soft starter).

The normally used accel./decel. function (C1-□□ parameters) is allocated after PID control so that, depending on the settings, resonance with the PID control and hunting in the machinery may occur. Using b5-17 this behavior can be prevented.

The PID soft starter function can also be disabled or enabled using a multifunction digital input (H1-□□ has to be set to 34).

■PID Feedback Loss Detection

When performing PID control, be sure to use the PID feedback loss detection function. Otherwise if the PID feedback gets lost, the Inverter output frequency may accelerate to the maximum output frequency.

Low Feedback (b5-12 = 1 or 2)

When b5-12 is set to 1 and the PID feedback value falls below the PID feedback loss detection level (b5-13) for a time longer than the PID feedback loss detection time (b5-14), a “FBL - Feedback Loss” alarm will be displayed at the operator and inverter operation is continued.

When the same happens and b5-12 is set to 2 a “FBL - Feedback Loss” fault will be displayed on the digital operator and the inverter operation will be stopped. The motor coasts to stop and the fault contact is operated.

The time chart for PID feedback loss detection is shown below.

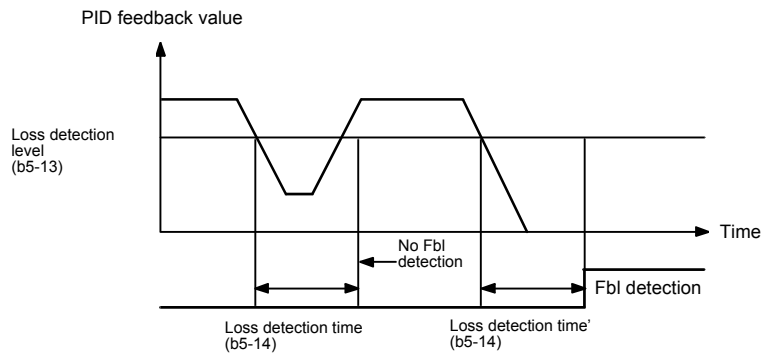

Fig 6.81 Low PID Feedback Loss Detection Time Chart

High Feedback (b5-12 = 3 or 4)

When b5-12 is set to 3 and the PID feedback value exceeds the PID feedback loss detection level (b5-13) for a time longer than the PID feedback loss detection time (b5-14), a “FBL - Feedback Loss” alarm will be displayed at the operator and inverter operation is continued.

When the same happens and b5-12 is set to 4 a “FBL - Feedback Loss” fault will be displayed on the digital operator and the inverter operation will be stopped. The motor coasts to stop and the fault contact is operated.

The time chart for PID feedback loss detection is shown below.

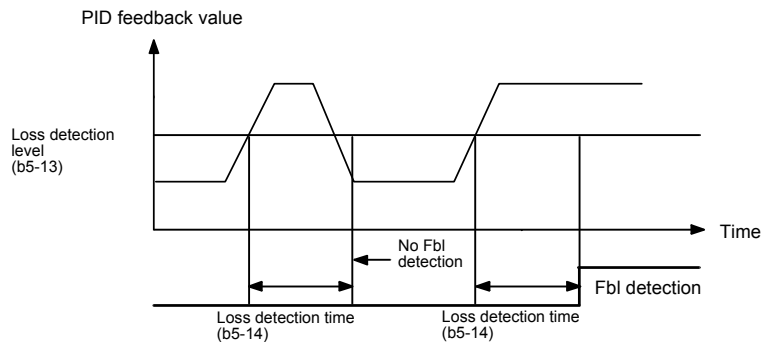

Fig 6.82 High PID Feedback Loss Detection Time Chart

■PID Sleep

The PID sleep function stops the Inverter when the PID output value falls below the sleep operation level (b5-15) for the sleep operation time set in parameter b5-16. The inverter operation will resume, if the PID output value exceeds the sleep operation level for the time set in parameter b5-16 or longer.

The PID sleep function works as well when the PID control is disabled. In this case the frequency reference value is observed by the sleep function instead of the PID output value.

The PID sleep time chart is shown below.

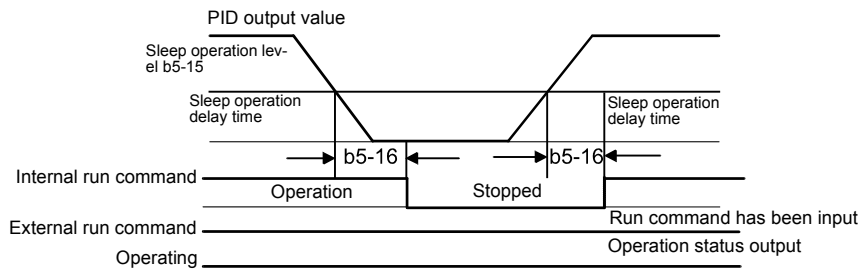

Fig 6.83 PID Sleep Time Chart

■Square Root Feedback Operation

If parameter b5-28 is set to 1, the feedback value is converted into a value that equals the square root of the actual feedback. This can be used to control the flow rate when a pressure sensor is used to generate a feedback value. Using parameter b5-29 the square root feedback can be multiplied with a factor. Following formula applies:

$$\text{Flow rate} = \text{Gain (b5-29)} \times \sqrt{\text{Pressure (head)}}$$

So linear connection between the PID target value and the feedback can be realized.

■PID Monitor Feedback Function

Using this function an internal monitor (U1-□□) can be set as PID feedback value. The monitor item can be selected in parameter b5-31. The following set values are possible:

Set Value	Function	Control Methods			
		V/f	V/f with PG	Open loop Vector	Closed Loop Vector
0	Disabled	Yes	Yes	Yes	Yes
3	Output current	Yes	Yes	Yes	Yes
5	Motor Speed	No	Yes	Yes	Yes
6	Output voltage	Yes	Yes	Yes	Yes
7	DC bus voltage	Yes	Yes	Yes	Yes
8	Output power	Yes	Yes	Yes	Yes
9	Torque reference	No	No	Yes	Yes
15	Terminal A1 input level	Yes	Yes	Yes	Yes
16	Terminal A2 input level	Yes	Yes	Yes	Yes
18	Motor secondary current	Yes	Yes	Yes	Yes

■ Multifunction Digital Input Settings: H1-01 to H1-05 (Terminal S3 to S7)

PID Control Disable: “19”

- If a multifunction input is set for this function it can be used to disable the PID function by switching the input to ON.
- The PID target value becomes the frequency reference value.

PID Control Integral Reset: “30”

- Using this function the integral share value of the PID control can be reset by setting a multifunction input to ON.

PID Control Integral Hold: “31”

- Using this function the integral share value of the PID control can be hold by setting a multifunction input to ON. The value will be hold as long as the input is ON.

PID Softstarter Disable: “34”

- Using this function the PID softstarter can be disabled or enabled. It is disabled if the input is activated.

PID Input Characteristic Switch: “35”

- Using this function the PID input characteristic can be inverted by setting a multifunction input to ON.

◆ Energy-saving

To use the energy saving function, set b8-01 (Energy Saving Mode Selection) to 1. Energy-saving control can be performed in all control methods. The parameters to be adjusted are different for each. In the V/f control modes adjust b8-04 to b8-05. In Open Loop and Closed Loop Vector control adjust b8-02 and b8-03.

■ Related Parameters

Parameter No.	Name	Factory Setting	Change during Operation	Control Methods			
				V/f	V/f with PG	Open Loop Vector	Closed Loop Vector
b8-01	Energy-saving mode selection	0	No	A	A	A	A
b8-02	Energy-saving gain	0.7 ^{*1}	Yes	No	No	A	A
b8-03	Energy-saving filter time constant	0.50 s ^{*2}	Yes	No	No	A	A
b8-04	Energy-saving coefficient	*3	No	A	A	No	No
b8-05	Power detection filter time constant	20 ms	No	A	A	No	No
b8-06	Search operation voltage limiter	0%	No	A	A	No	No
E2-02	Motor rated slip	2.90 Hz ^{*3}	No	A	A	A	A
E2-11	Motor rated output power	0.40 ^{*3}	No	Q	Q	Q	Q

* 1. The value for Open Loop Vector control is given. The factory setting is 1.0 in Closed Loop Vector control.

* 2. The factory setting is 2.00 s for Inverters larger than 55 kW.

* 3. The factory settings depend on the Inverter capacity.

■ Adjusting Energy-saving Control

The method of adjusting the energy-saving control function depends on the control method. Refer to the following when making adjustments.

V/f Control Modes

In the V/f control modes the voltage for optimum motor efficiency is calculated and becomes the output voltage reference.

- b8-04 (Energy-saving Coefficient) is preset assuming that motor and inverter capacity are the same. If the inverter capacity differs from the motor capacity, set the motor capacity in E2-11 (Motor Rated Output Power). Also, adjust b8-04 in steps of 5 % until the output power reaches its minimum. The higher the energy-saving coefficient, the higher is the output voltage.
- To improve the responsiveness when the load fluctuates, reduce the power detection filter time parameter b8-05. If b8-05 is set too small, however, the motor rotations may become unstable under light load conditions.
- Motor efficiency varies due to temperature fluctuations and differences in motor characteristics. Consequently the motor efficiency has to be controlled. To have optimized efficiency, the search operation varies the output voltage. Parameter b8-06 (Search Operation Voltage Limiter) limits the range for the voltage search operation. For 200 V Class Inverters, a range of 100% is equal to 200 V and for 400 V Class Inverters a range of 100% is equal to 400 V. Set b8-06 to 0 to disable the search operation voltage limiter.

Open Loop and Closed Loop Vector Control

In Open Loop and Closed Loop Vector control, the slip frequency is controlled so that motor efficiency is maximized.

- Taking the motor rated slip for the base frequency as optimum slip, the inverter calculates the slip for the optimal motor efficiency depending on the output frequency.
- Before using energy saving always perform autotuning.
- If hunting occurs reduce the set value in b8-02 (Energy-saving Gain), or increase the set value in b8-03 (Energy-saving Filter Time Constant).

◆ Field Weakening

The field weakening function is used to lower the output voltage when the motor load changes to a low level (no load). Thereby energy can be saved and motor audible noise is reduced.

Note that this function is designed for the usage with one low load condition that does not change. If the low load condition changes, the field weakening function can not be optimized. In this case the energy saving function should be preferred.

The function can be activated using a multifunction input. Therefore set one of the parameters H1-01 to H1-05 to 63.

Field weakening can be used in the V/f control modes only.

■ Related Parameters

Parameter No.	Name	Factory Setting	Change during Operation	Control Methods			
				V/f	V/f with PG	Open Loop Vector	Closed Loop Vector
d6-01	Field weakening level	80%	No	A	A	No	No
d6-02	Field weakening frequency limit	0.0 Hz	No	A	A	No	No

Multi-function Digital Inputs (H1-01 to H1-05)

Set Value	Function	Control Methods			
		V/f	V/f with PG	Open Loop Vector	Closed Loop Vector
63	Field Weakening	Yes	Yes	No	No

■ Setting the Field Weakening Level (d6-01)

To set the field weakening level run the motor under low load condition and activate the field weakening function using a multifunction input. Monitor the output current and raise or lower the field weakening level until the output current reaches its minimum value.

Observe the following:

- Parameter d6-01 can not be changed during operation (i.e. a RUN command is input).
- If the field weakening level is set too low, the motor may stall.

■ Activating Field Weakening

If one of the parameters H1-01 to H1-05 is set to “63”, the field weakening function can be activated switching the regarding terminal input to ON.

◆ Field Forcing

The field forcing function controls the motor flux and compensates the flux establishment delay of the motor. Thereby it improves the motor responsiveness on changes in the speed reference or the load. Field forcing is applied during all operation conditions except DC Injection.

Using parameter d6-04 a field forcing limit can be applied. A setting of 100% is equal to the no-load current set in parameter E2-03.

■ Related Parameters

Parameter No.	Name	Factory Setting	Change during Operation	Control Methods			
				V/f	V/fwith PG	Open Loop Vector	Closed Loop Vector
d6-03	Field forcing selection	0	No	No	No	No	A
d6-04	Field forcing limit	400%	No	No	No	A	A

◆ Setting Motor 1 Parameters

In vector control method, the motor parameters are set automatically during autotuning. If autotuning does not complete normally, set them manually.

■ Related Parameters

Parameter No.	Name	Factory Setting	Change during Operation	Control Methods			
				V/f	V/fwith PG	Open Loop Vector	Closed Loop Vector
E2-01	Motor rated current	1.90 A *	No	Q	Q	Q	Q
E2-02	Motor rated slip	2.90 Hz *	No	A	A	A	A
E2-03	Motor no-load current	1.20 A *	No	A	A	A	A
E2-04	Number of motor poles (Number of poles)	4 poles	No	No	Q	Q	Q
E2-05	Motor line-to-line resistance	9.842 Ω *	No	A	A	A	A
E2-06	Motor leak inductance	18.2%	No	No	No	A	A
E2-07	Motor iron saturation coefficient 1	0.50	No	No	No	A	A
E2-08	Motor iron saturation coefficient 2	0.75	No	No	No	A	A
E2-10	Motor iron loss for torque compensation	14 W *	No	A	A	No	No
E2-11	Motor rated output power	0.40 *	No	Q	Q	Q	Q

Note: All factory-set parameters are for a standard 4-pole motor.

* The factory settings depend on Inverter capacity (the values shown are for a 200 V Class Inverter for 0.4 kW).

■ Manual Setting of the Motor Parameters

Motor Rated Current Setting (E2-01)

Set E2-01 to the rated current value on the motor nameplate.

Motor Rated Slip Setting (E2-02)

Set E2-02 to the motor rated slip calculated from the number of rated rotations on the motor nameplate.

$$\text{Motor Rated Slip} = \text{Motor rated frequency (Hz)} - \frac{\text{Rated Speed (rpm)} \times \text{No. of motor poles}}{120}$$

Motor No-Load Current Setting (E2-03)

Set E2-03 to the motor no-load current at the rated voltage and rated frequency. Normally, the motor no-load current is not written on the motor nameplate. Consult the motor manufacturer.

Factory setting is the no-load current value for a standard 4-pole motor.

Number of Motor Poles Setting (E2-04)

E2-04 is displayed in V/f control with PG, Open Loop and Closed Loop Vector mode only. Set the number of motor poles as written on the motor nameplate.

Motor Line-to-Line Resistance Setting (E2-05)

E2-05 is set automatically when performing motor line-to-line resistance autotuning. When you cannot perform tuning, consult the motor manufacturer for the line-to-line resistance value. Calculate the resistance from the line-to-line resistance value in the motor test report using the following formula, and then make the setting accordingly.

- E-type insulation: [Line-to line resistance (Ω) at 75°C of test report] \times 0.92 (Ω)
- B-type insulation: [Line-to line resistance (Ω) at 75°C of test report] \times 0.92 (Ω)
- F-type insulation: [Line-to line resistance (Ω) at 115°C of test report] \times 0.87 (Ω)

Motor Leak Inductance Setting (E2-06)

Set the amount of voltage drop due to motor leakage inductance in E2-06 as percentage of the motor rated voltage. Make this setting when using high-speed motors because the standard value will be too high. (Normally, high speed motors have a low inductance compared to standard motors.) If the inductance is not written on the motor nameplate, consult the motor manufacturer.

Motor Iron Saturation Coefficients 1 and 2 Settings (E2-07)

E2-07 and E2-08 are set automatically during rotating autotuning.

Motor Iron Loss for Torque Compensation Setting (E2-10)

E2-10 is displayed only in V/f control method and can be set to increase the torque compensation accuracy. The motor iron loss has to be set in kW.

◆ Setting the V/f Pattern 1

Using the E1-□□ parameters the Inverter input voltage and the V/f pattern can be set as needed. It is not recommended to change the settings when the motor is used in Open Loop or Closed Loop vector control mode.

■ Related Parameters

Parameter No.	Name	Factory Setting	Change during Operation	Control Methods			
				V/f	V/f with PG	Open Loop Vector	Closed Loop Vector
E1-01	Input voltage setting	200 V *1	No	Q	Q	Q	Q
E1-03	V/f pattern selection	F	No	Q	Q	No	No
E1-04	Max. output frequency (FMAX)	50.0 Hz	No	Q	Q	Q	Q
E1-05	Max. voltage (VMAX)	200.0 V *1	No	Q	Q	Q	Q
E1-06	Base frequency (FA)	50.0 Hz	No	Q	Q	Q	Q
E1-07	Mid. output frequency (FB)	3.0 Hz *2	No	A	A	A	No
E1-08	Mid. output frequency voltage (VB)	13.2 V *1*2	No	A	A	A	No
E1-09	Min. output frequency (FMIN)	0.5 Hz *2	No	Q	Q	Q	A
E1-10	Min. output frequency voltage (VMIN)	2.4 V *1*2	No	A	A	A	No
E1-11	Mid. output frequency 2	0.0 Hz *3	No	A	A	A	A
E1-12	Mid. output frequency voltage 2	0.0 V *3	No	A	A	A	A
E1-13	Base voltage (VBASE)	0.0 V *4	No	A	A	Q	Q

* 1. These are values for a 200 V Class Inverter. Values for a 400 V Class Inverter are double.

* 2. The factory setting will change when the control method is changed. (Open Loop Vector control factory settings are given.)

* 3. The contents of parameters E1-11 and E1-12 are ignored when set to 0.00.

* 4. E1-13 is set to the same value as E1-05 by autotuning.

■ Setting Inverter Input Voltage (E1-01)

Set the Inverter input voltage correctly in E1-01 so that it matches the power supply voltage. This set value will be the reference value for the protection functions and similar functions (overvoltage level, stall level).

■ Setting V/f Pattern (E1-02)

The V/f pattern can be selected using parameter E1-03. There are two methods of setting the V/f pattern: Select one of the 15 preset pattern types (set value: 0 to E), or set a user-defined V/f pattern (set value: F).

The factory setting for E1-03 is F.

To select one of the existing patterns, refer to the following table.

Characteristic	Application	Set Value	Specifications
Constant Torque Characteristic	These patterns are used in general applications where the load torque is fixed, regardless of rotation speed, e.g. for linear transport systems.	0 (F)	50 Hz specifications
		1	60 Hz specifications
		2	60 Hz specifications, voltage saturation at 50 Hz
		3	72 Hz specifications, voltage saturation at 60 Hz
Variable torque characteristic	These patterns are used for loads with torque proportional to the square or cube of the rotation speed, such as fans and pumps.	4	50 Hz specifications, cubical torque characteristic
		5	50 Hz specifications, quadratic torque characteristic
		6	60 Hz specifications, cubical torque characteristic
		7	60 Hz specifications, quadratic torque characteristic
High Startup Torque (See Note)*	Select a high startup torque V/f pattern only in the following cases. <ul style="list-style-type: none"> • The wiring distance between Inverter and motor is large (Pyrex. 150 m min.) • A large torque is required at startup • An AC reactor is inserted in the Inverter input or output. 	8	50 Hz specifications, medium startup torque
		9	50 Hz specifications, large startup torque
		A	60 Hz specifications, medium startup torque
		B	60 Hz specifications, large startup torque
Fixed Output Operation	This pattern is used for frequencies of 60 Hz or higher. A fixed voltage is applied.	C	90 Hz specifications, voltage saturation at 60 Hz
		D	120 Hz specifications, voltage saturation at 60 Hz
		E	180 Hz specifications, voltage saturation at 60 Hz

* The high start up torque is provided by the automatic torque compensation function, so normally there is no need to use this pattern.

When you select these patterns, the values of parameters E1-04 to E1-10 are changed automatically. There are three types of values for E1-04 to E1-10, depending on the Inverter capacity.

- 0.4 to 1.5 kW V/f pattern
- 2.2 to 45 kW V/f pattern
- 55 to 300 kW V/f pattern

The characteristics diagrams for each are shown in the following pages.

0.4 to 1.5 kW V/f Pattern

The diagrams show characteristics for a 200-V class motor. For a 400-V class motor, multiply all voltages by 2.

- Constant Torque Characteristics (Set Value: 0 to 3)

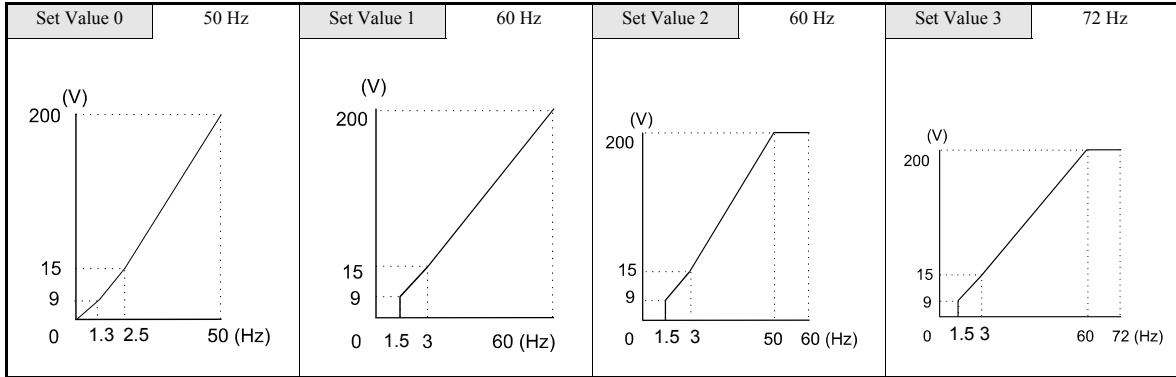

- Variable Torque Characteristics (Set Value: 4 to 7)

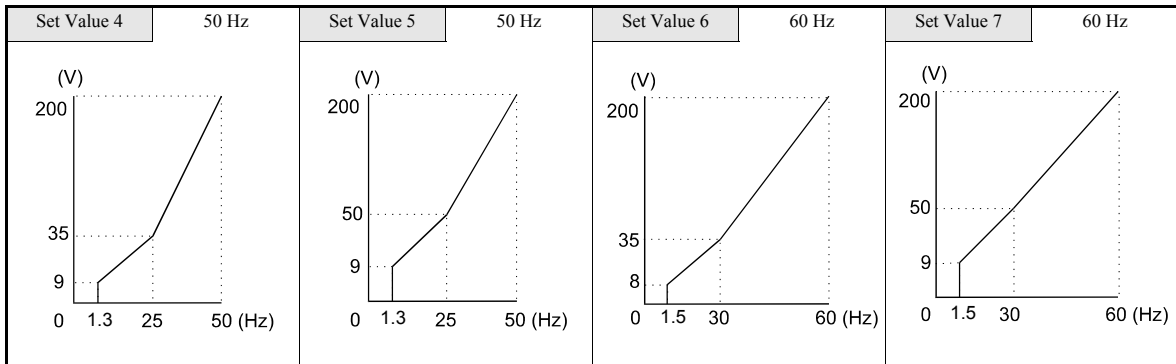

- High startup torque (Set value 8: to b)

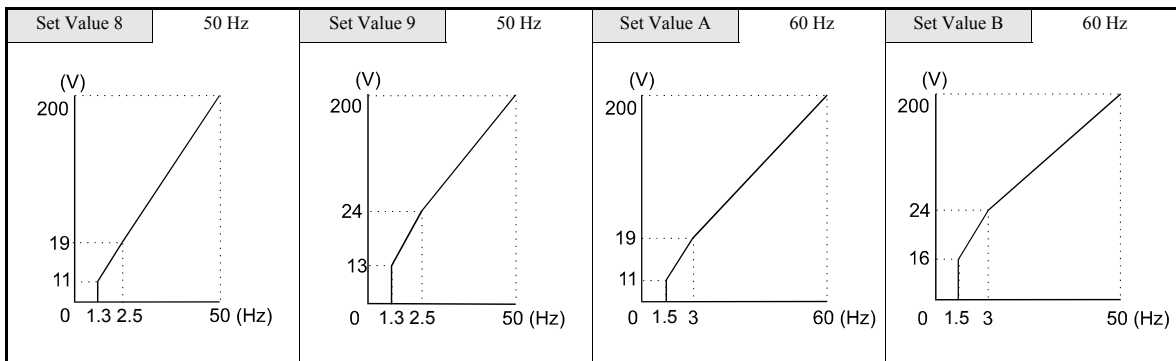

- Fixed Output Operation (Set Value: C to E)

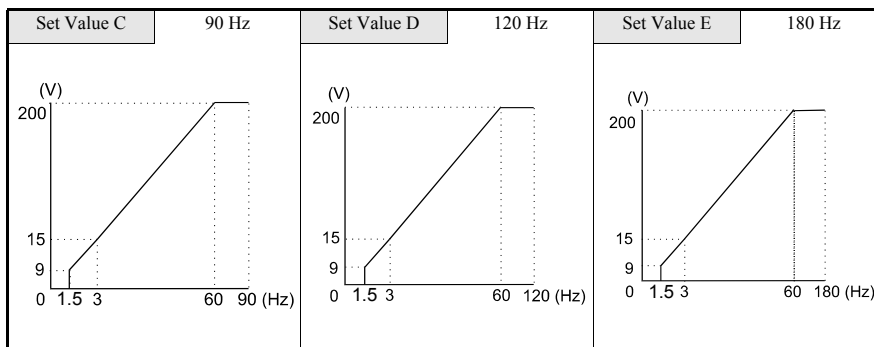

2.2 to 45 kW V/f Pattern

The diagrams show characteristics for a 200-V class motor. For a 400-V class motor, multiply all voltages by 2.

- Constant Torque Characteristics (Set Value: 0 to 3)

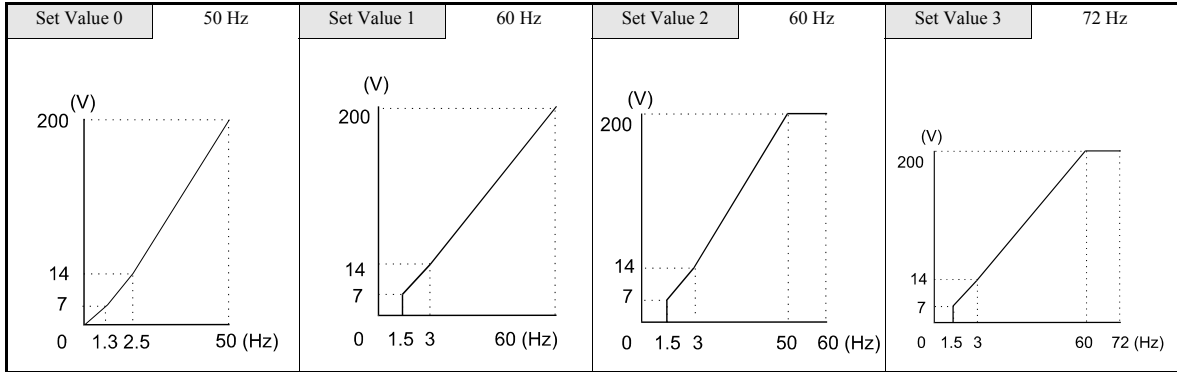

- Variable Torque Characteristics (Set Value: 4 to 7)

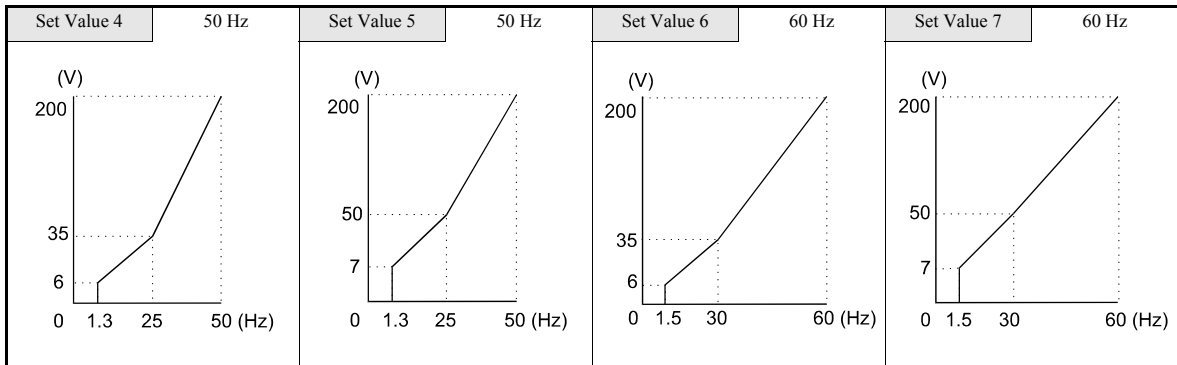

- High Startup Torque (Set Value: 8 to b)

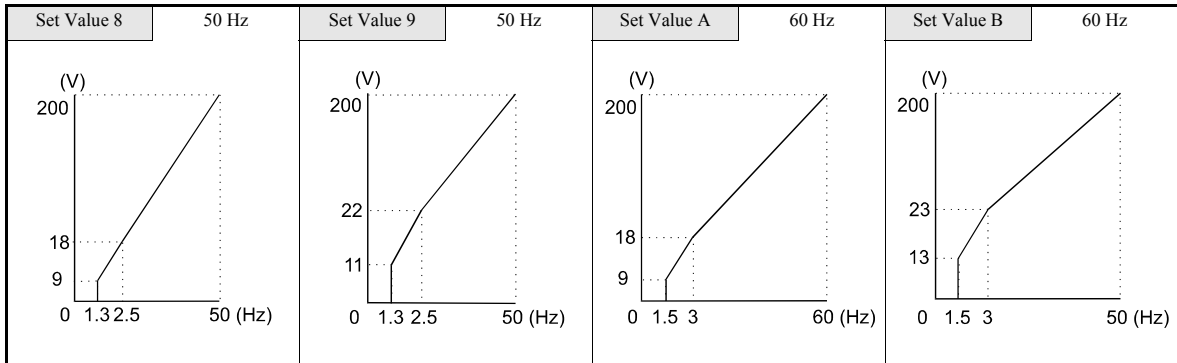

- Fixed Output Operation (Set Value: C to E)

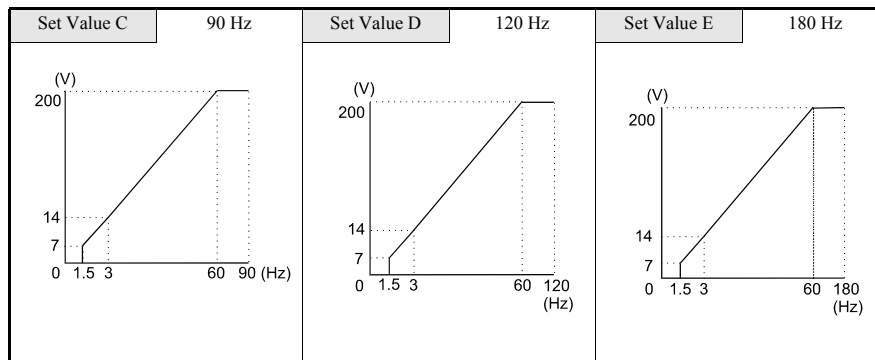

55 to 300 kW V/f Pattern

The diagrams show characteristics for a 200-V class motor. For a 400-V class motor, multiply all voltages by 2.

- Constant Torque Characteristics (Set Value: 0 to 3)

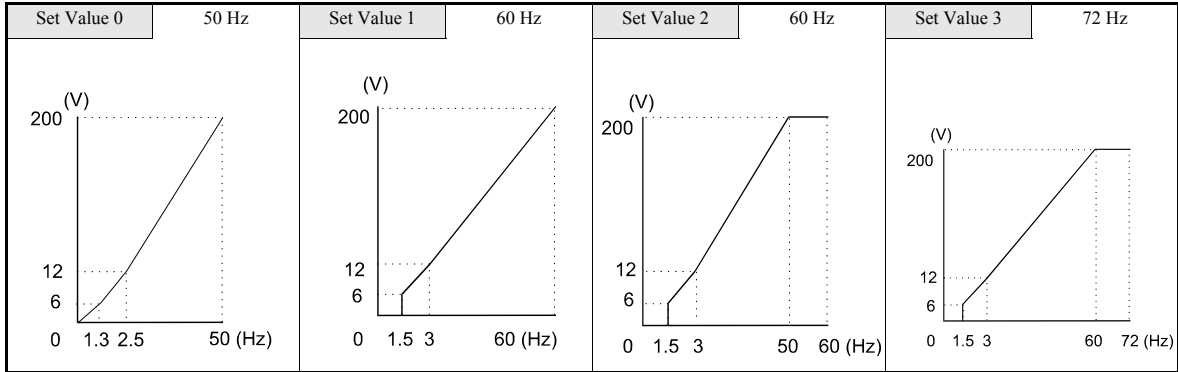

- Variable Torque Characteristics (Set Value: 4 to 7)

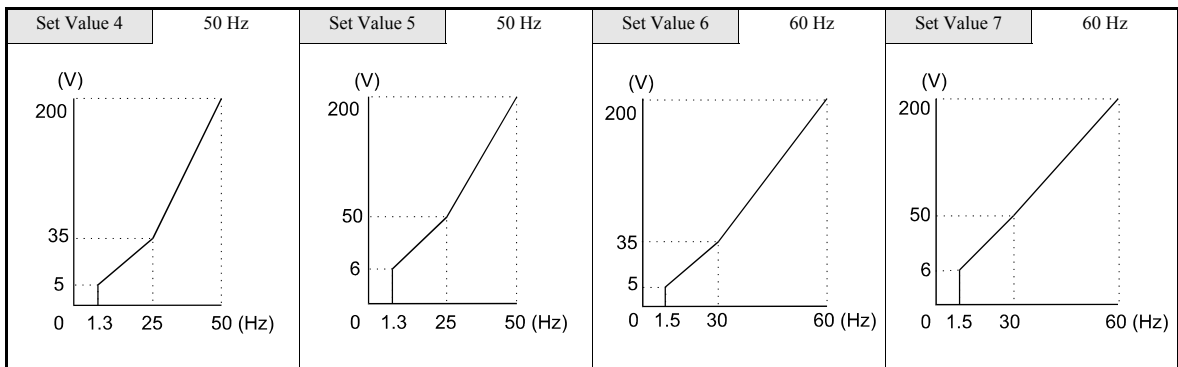

- High Startup Torque (Set Value: 8 to b)

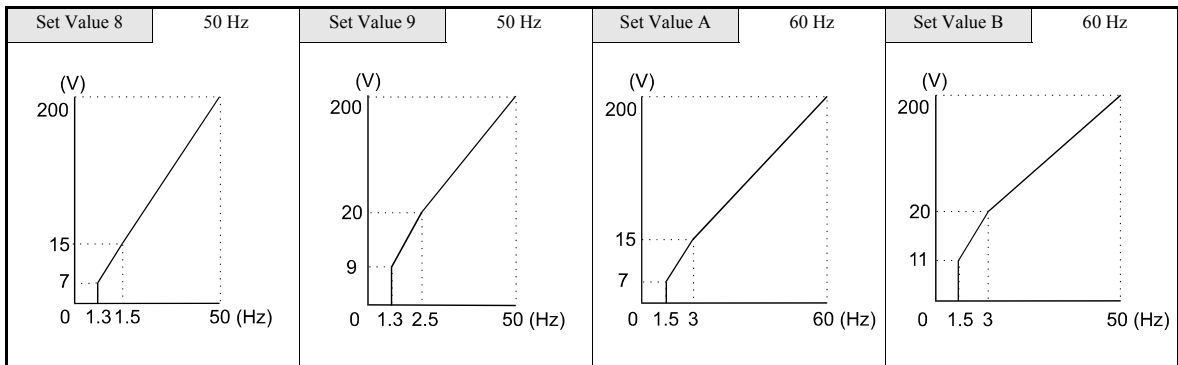

- Fixed Output Operation (Set Value: C to E)

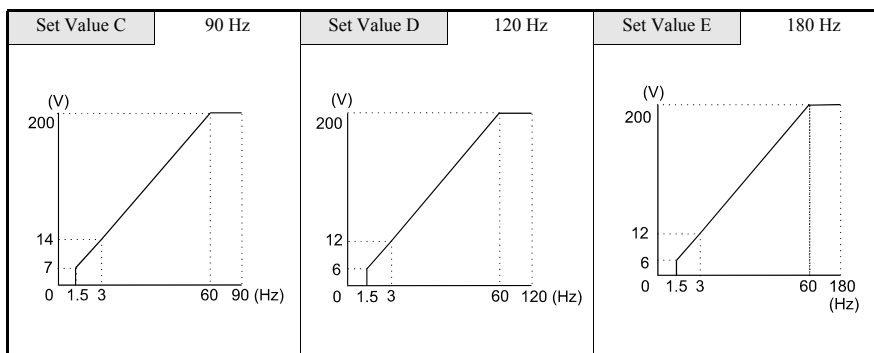

■ Setting an Individual V/f Pattern

If E1-03 is set to F the V/f pattern can be set individually using the parameters E1-04 to E1-10. See [Fig 6.84](#) for details.

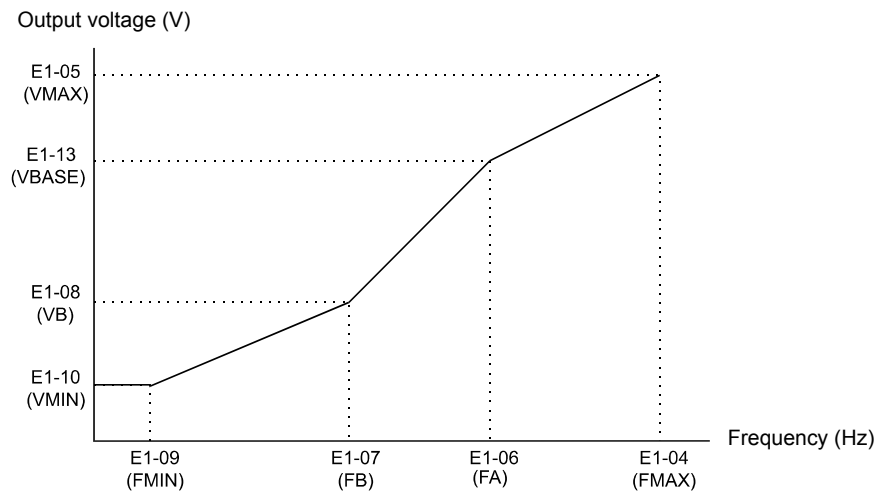

Fig 6.84 Individual V/f pattern setting



INFO

- If E1-03 is set to anything other than F, you can only read parameters E1-04 to E1-10.
- To set the V/f characteristics linear, set E1-07 and E1-09 to the same value. In this case, E1-08 will be ignored.

■ Setting Precautions

When the setting is to user-defined V/f pattern, beware of the following points:

- When changing control method, parameters E1-07 to E1-10 will change to the factory settings for that control method.
- Be sure to set the four frequencies as follows:
 $E1-04 (FMAX) \geq E1-06 (FA) > E1-07 (FB) \geq E1-09 (FMIN)$

◆ Setting Motor 2 Parameters

The E4-□□ parameters are for setting the motor data for motor 2. In the Vector Control modes the motor data are set automatically by autotuning. If the autotuning does not complete normally, set them manually (refer to [page 6-109, Manual Setting of the Motor Parameters](#)).

To switch over between motor 1 and 2 a digital input must be set for the motor switch over command (one of the parameters H1-01 to H1-05 must be set to 16). Motor 2 is selected when the input is switched ON. In this case the V/f pattern settings in the parameters E3-□□ are used.

Note: Autotuning for motor 2 can only be performed if one multifunction input H1-□□ is set to 16 (Motor 2 selection). Otherwise motor 2 cannot be selected during autotuning (T1-00 will not be shown).

■ Related parameters

Parameter No.	Name	Factory Setting	Change during Operation	Control Methods			
				V/f	V/f with PG	Open Loop Vector	Closed Loop Vector
E4-01	Motor 2 rated current	1.90 A *	No	A	A	A	A
E4-02	Motor 2 rated slip	2.90 Hz *	No	A	A	A	A
E4-03	Motor 2 no-load current	1.20 A *	No	A	A	A	A
E4-04	Motor 2 number of poles (number of poles)	4 poles	No	No	A	No	A
E4-05	Motor 2 line-to-line resistance	9.842 Ω *	No	A	A	A	A
E4-06	Motor 2 leak inductance	18.2%	No	No	No	A	A
E4-07	Motor 2 rated capacity	0.40 *	No	A	A	A	A

* The factory setting depends upon the inverter capacity. The value for a 200 V class inverter of 0.4 kW is given.

Multi-function Digital Inputs (H1-01 to H1-05)

Set Value	Function	Control Methods			
		V/f	V/f with PG	Open Loop Vector	Closed Loop Vector
16	Motor 1/2 switch over	Yes	Yes	Yes	Yes

◆ Setting the V/f Pattern 2

Using the E3-□□ parameters the V/f pattern for motor 2 can be set as needed.

It is not recommended to change the settings when the motor is used in open loop vector mode.

■ Related Parameters

Parameter No.	Name	Factory Setting	Change during Operation	Control Methods			
				V/f	V/f with PG	Open Loop Vector	Closed Loop Vector
E3-01	Motor 2 control method selection	0	No	A	A	A	A
E3-02	Motor 2 max. output frequency (FMAX)	50.0 Hz	No	A	A	A	A
E3-03	Motor 2 max. output voltage (VMAX)	200.0 V *1	No	A	A	A	A
E3-04	Motor 2 max. voltage frequency (FA)	50.0 Hz	No	A	A	A	A
E3-05	Motor 2 mid. output frequency 1 (FB)	3.0 Hz *2	No	A	A	A	No
E3-06	Motor 2 mid. output frequency voltage 1 (VB)	13.2 V *1*2	No	A	A	A	No
E3-07	Motor 2 min. output frequency (FMIN)	0.5 Hz *2	No	A	A	A	A
E3-08	Motor 2 min. output frequency voltage (VMIN)	2.4 V *1*2	No	A	A	A	No

* 1. These are values for a 200 V class inverter. Values for a 400 V class inverter are double

* 2. The factory setting will change when the control method is changed. (Open Loop Vector control factory settings are given.)

■ Selecting the Motor 2 Control Method (E3-01)

Using parameter E3-01 the control method for motor 2 can be selected.

- The setting of this parameter affects the autotuning function. If V/f or V/f with PG is selected the only possible autotuning method will be stationary autotuning for line-to-line resistance.

■ Setting the V/f Pattern Characteristic

The principle of setting the V/f pattern 2 is the same as for V/f pattern 1. Please refer to [page 6-111, Setting V/f Pattern \(E1-02\)](#) for details.

Note: The V/f pattern 2 settings are only used for motor 2, i.e. motor 2 has to be selected using a multi-function input (setting 16).

◆ Torque Control

With Closed Loop Vector control the motor's output torque can be controlled by a torque reference from an analog input. Torque control can be enabled by setting parameter d5-01 to 1.

■ Related Parameters

Parameter No.	Name	Factory Setting	Change during Operation	Control Methods			
				V/f	V/f with PG	Open Loop Vector	Closed Loop Vector
d5-01	Torque control selection	0	No	No	No	No	A
d5-02	Torque reference delay time	0 ms	No	No	No	No	A
d5-03	Speed limit selection	1	No	No	No	No	A
d5-04	Speed limit	0%	No	No	No	No	A
d5-05	Speed limit bias	10%	No	No	No	No	A
d5-06	Speed/torque control switching timer	0 ms	No	No	No	No	A

Multi-function Digital Inputs (H1-01 to H1-05)

Set Value	Function	Control Methods			
		V/f	V/f with PG	Open Loop Vector	Closed Loop Vector
71	Speed/torque control change (ON: Torque control)	No	No	No	Yes
78	Polarity reverse command for external torque reference	No	No	No	Yes

Multifunction Outputs (H2-01 to H2-03)

Set Value	Function	Control Methods			
		V/f	V/f with PG	Open Loop Vector	Closed Loop Vector
31	During speed limit	No	No	No	Yes
32	Activated if the speed control circuit (ASR) is operating for torque control. The ASR output becomes the torque reference. The motor is rotating at the speed limit.	No	No	No	Yes

Multi-Function Analog Input (H3-09)

Set Value	Function	Control Methods			
		V/f	V/f with PG	Open Loop Vector	Closed Loop Vector
0	Add to terminal A1	Yes	Yes	Yes	Yes
13	Torque reference/torque limit at speed control	No	No	No	Yes
14	Torque compensation	No	No	No	Yes

Monitors

Parameter Number	Name	Description	Output Signal Level at Analog Output	Min. Unit	Control Methods			
					V/f	V/f with PG	Open Loop Vector	Closed Loop Vector
U1-09	Torque reference	Monitor in internal torque reference value for vector control.	10 V: Motor rated torque (0 to ± 10 V possible)	0.1%	No	No	Yes	Yes

■ Torque Control Operation

In torque control a torque value can be given as reference for the motor output. If the torque command and the load are not balanced, the motor accelerates or decelerates.

The speed limit circuit prevents the motor speed from rising above certain value set by an analog input or parameter d5-04. The speed limit function mainly consists of two parts, the priority circuit and the speed limiter circuit.

The priority circuit selects between the torque reference value from the analog input or from the speed controller (ASR) output. If the output speed is below the speed limit, the analog input value is taken as torque reference. Otherwise the ASR output value is taken as torque reference.

The speed limit circuit adds a speed suppressing torque to the torque output if the speed exceeds the speed limit. Together with the priority circuit it prevents the output speed from exceeding the speed limit.

The torque control block diagram is shown in [Fig 6.85](#).

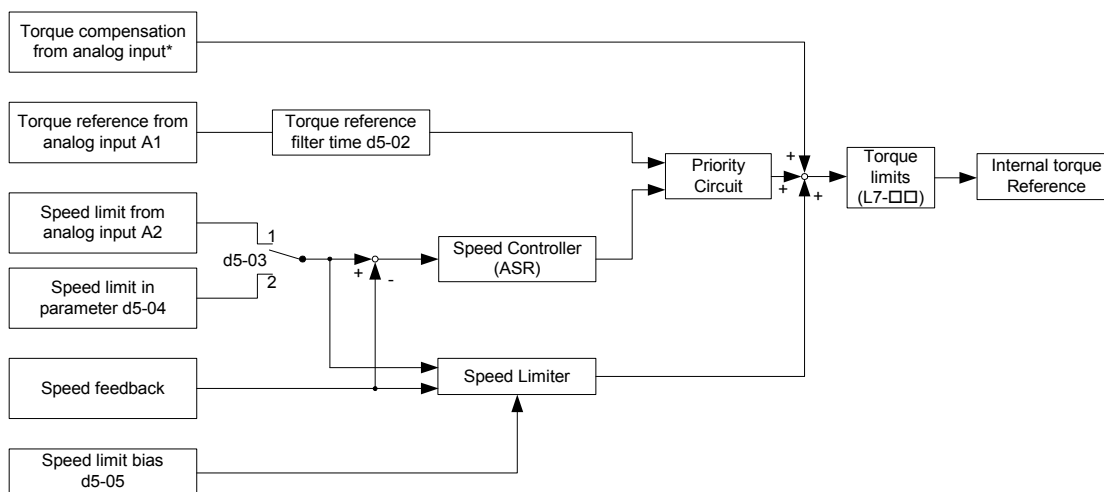

Fig 6.85 Torque Control Block Diagram

■ Inputting Torque References and Torque Reference Directions

The torque reference can be input using an analog voltage or current signals. The torque reference input methods are listed in the table below.

Torque Reference Input Method	Reference Location	Selection Method	Remarks
Voltage input (0 to 10 V)	Analog input A2 (Turn OFF pin 2 of SW1.)	H3-08 = 0 H3-09 = 13	To switch the torque reference between positive and negative torque, use a digital input (H1-□□ = 78).
Voltage input (-10 to +10 V)	Analog input A2 (Turn OFF pin 2 of SW1.)	H3-08 = 1 H3-09 = 13	The torque reference direction is switched with the analog input voltage direction.
Current input (4 to 20 mA)	Analog input A2 (Turn ON pin 2 of SW1.)	H3-08 = 2 H3-09 = 13	To switch the torque reference between positive and negative torque, use a digital input (H1-□□ = 78).
Option Card (AI-14B) (0 to ±10 V)	Channel 2	b1-01=1 F2-01 = 0 H3-08 = 1 H3-09 = 13	Channel 1 of the AI-14B card replaces analog input A1

The direction of the torque output from the motor will be determined by the sign of the analog signal input or a digital input command. It does not depend on the direction of the run command. The direction of torque will be as follows:

- Positive analog reference: Torque reference for forward motor rotation (counterclockwise as viewed from the motor output axis).
- Negative analog reference: Torque reference for reverse motor rotation (clockwise as viewed from the motor output axis).

■ Inputting the Speed Limit

- The inputs methods for a speed limit are listed in the following table.

Speed Limit Input Method	Location of Reference	Parameter Settings	Remarks
Parameter setting	Set in d5-04	d5-03 = 2	-
Voltage input (0 to +10 V)	Analog input A1	b1-01 = 1 H3-01 = 0	Use this setting if the speed limit has always to be positive.
Voltage input (-10 to +10 V)	Analog input A1	b1-01 = 1 H3-01 = 1	Use this setting when a speed limit for both directions has to be applied.
Current input (4 to 20 mA)	Analog input A2	b1-01 = 1 H3-08 = 2 H3-09 = 13 H3-13 = 1	Terminal A1 becomes the torque reference value. Turn ON (I side) pin 2 of DIP switch S1 on the terminal board.
Option Card (AI-14B) (0 to ±10 V)	Channel 1	b1-01 = 1 F2-01 = 0	Channel 1 of the AI-14B card replaces analog input A1
	Channel 1 to 3	b1-01 = 3 F2-01 = 1	The sum of the channels 1 to 3 is taken as speed limit.

The direction in which speed is controlled is determined by the sign of the speed limit signal and the direction of the run command.

- Positive voltage applied: The speed in the forward direction will be limited for forward operation.
- Negative voltage applied: The speed in the reverse direction will be limited for reverse operation.

If the direction of the motor rotation and the speed limit direction are not the same, the speed will be limited to 0.

■ Digital Output Functions (H2-01 to H2-03)

During Speed Limit (“31”)

If a digital output is set for this function the output is activated, if the output speed is at the speed limit.

ASR active for Torque Control (“32”)

Using this output function a digital output can be used to monitor the status of the speed limit function. The output is switched:

- ON, if the torque reference is taken from the ASR output and the motor is operating at the speed limit
- OFF, if the torque reference is taken from the analog input

Speed Limit Bias Setting

The speed limit bias can be set to limit both the forward and reverse speed to the same value. This differs from the operation of the speed limit setting. To use the speed limit bias, set d5-04 to 0 and set the bias in d5-05 as a percentage of the maximum output frequency.

To set 50% forward and reverse speed limits, set the speed limit setting to 0 (d5-03 = 2, d5-04 = 0, and d5-05 = 50). The range of torque control will be from -50% to 50% of the maximum output speed.

When using both, the speed limit and the speed limit bias, the speed range of torque control will be the positive and negative speed limits with the speed limit bias added to each.

Example

The speed range of torque control when the forward speed limit is 50% and the speed limit bias is 10% is shown in Fig 6.86. This figure does not take the priority circuit into account.

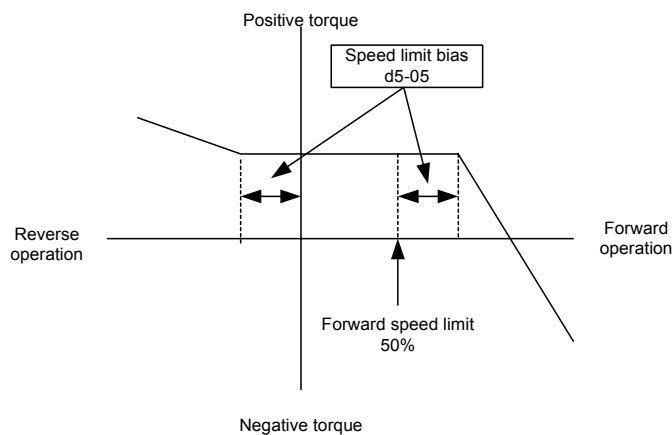

Fig 6.86 Speed Limit Bias Setting

Torque Control Operation Examples

Operation examples will be described separately for winding operation, in which the speed and motor torque are in the same directions, and rewinding operation, in which the speed and motor torque are in opposite directions.

Winding Operation

In a winding operation, the line (speed) and torque generated by the motor are in the same direction. For the winding operation, both the speed limit and the torque reference input are positive. The motor will accelerate when the torque reference input is larger than the load and will decelerate when it is smaller than the load. If the motor turns faster than the speed limit, a negative compensation value is output from the speed limiter circuit. When the speed then drops below the speed limit, a positive compensation value is output. The torque compensation is proportional to the ASR proportional gain. When the sum of the torque reference and the torque compensation output by the speed limiter is the same as the actual load, the motor will stop accelerating and run at a constant speed.

Rewinding Operation

In a rewinding operation, the line (speed) and torque generated by the motor are in the opposite directions. (In this example, it is assumed that the line speed is positive and the torque reference input is negative.) For the rewinding operation, the speed limit is positive and the torque reference input is negative. If the motor turns faster than the speed limit, a negative compensation value is output from the speed limiter circuit. If the motor is rotating in reverse, a positive compensation value is output. If the speed is 0 or is below the speed limit, a 0 compensation value is output. In this way, the output from the speed limiter is used to maintain the motor speed between 0 and the speed limit. When the sum of the torque reference and the torque compensation out-

put by the speed limiter is the same as the actual load, the motor will stop accelerating and run at a constant speed.

	Winding Operation		Rewinding Operation	
Configuration				
Normal Rotation Direction	Forward	Reverse	Forward	Reverse
Torque Reference Polarity (TREF)	\oplus	\ominus	\ominus	\oplus
Speed Limit Polarity (SLIM)	\oplus	\ominus	\oplus	\ominus
Generated Torque				

6

■ Torque Reference Signal Adjustments

Torque Reference Delay Time (d5-02)

The filter time constant in the torque reference section can be adjusted using parameter d5-02. This parameter is used to eliminate noise in the torque reference signal and adjust the responsiveness to the host controller. Increase the setting if oscillations occur during torque control.

Setting the Torque Compensation

An analog input can be used to apply a torque compensation (H3-09 = 14). When the amount of torque loss for mechanical loss or other influences at the load is input to one of this terminal, it is added to the torque reference to compensate the loss. The direction of torque will be as follows:

- Positive voltage (current): Torque compensation reference for forward motor rotation (counterclockwise as viewed from the motor output axis).
- Negative voltage: Torque compensation reference for reverse motor rotation (clockwise as viewed from the motor output axis).

Since the polarity of the voltage input determines the direction, only forward torque compensation can be input when the 0 to 10 V or 4 to 20 mA signal level has been selected. If a reverse torque compensation shall be input, be sure to select the 0 to ± 10 V signal level.

■ Speed/Torque Control Switching Function

It is possible to switch between speed control and torque control using one of the digital inputs (H1-□□ = 71, Speed/Torque Control Change). Speed control is performed when the input is OFF and torque control is performed when the input is ON. The parameter d5-01 has to be set to 0.

Setting the Speed/Torque Control Switching Timer (d5-06)

The delay between a change in the speed/torque control switching function input (ON to OFF or OFF to ON) and the corresponding change in the control mode can be set in parameter d5-06. During the timer delay, the value of the 2 analog inputs will retain the values they had when the ON/OFF status of speed/torque control switching signal was changed. Use this delay to complete any changes required in external signals.

Fig 6.87 shows an example of speed/torque control switching.

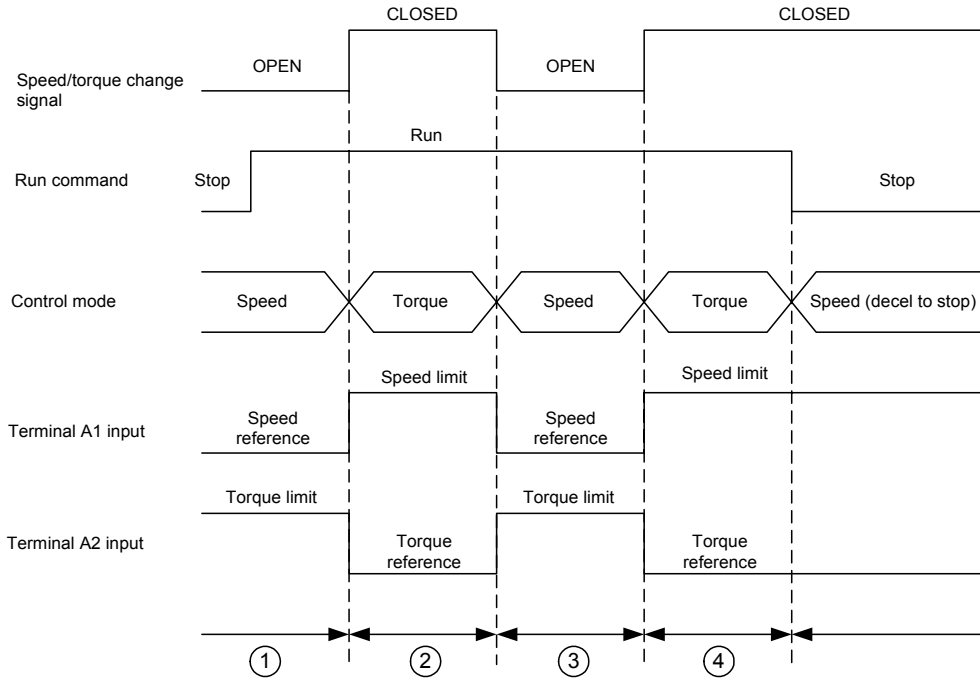

Fig 6.87 Speed/Torque Control Switching Time Chart

Application Precautions

- The function of the torque reference input (A1 or A2) changes when the control mode is switched between torque control and speed control.
 During speed control: The analog input terminal is used as the torque limit input.
 During torque control: The analog input terminal is used as the torque reference input.
- When the run command is turned OFF, the control method will be speed control. Even from the torque control mode, the system will automatically change to speed control and decelerate to a stop when the run command turns OFF.

◆ Droop Control Function

Droop control is a function that allows to achieve a load sharing between two motors that drive a single load. The Droop Control function must be enabled at one inverter only. If by this inverter the torque rises, the speed is reduced and the other inverter takes over more load. Thereby the load is shared automatically to both motors.

■ Related Constants

Parameter No.	Name	Factory Setting	Change during Operation	Control Methods			
				V/f	V/f with PG	Open Loop Vector	Closed Loop Vector
b7-01	Droop Control gain	0.0	Yes	No	No	No	A
b7-02	Droop Control delay time	0.05 s	No	No	No	No	A

■ Setting the Droop Control Gain

Set the Droop Control gain in parameter b7-01 to the amount of speed reduction when the maximum output frequency is input and the rated torque is generated (see [Fig 6.88](#)). b7-01 is set as percentage of the maximum output voltage.

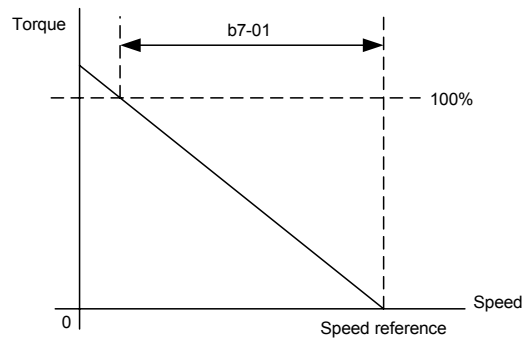

Fig 6.88 Droop Control Gain

Droop Control can be disabled by setting the parameter b5-07 to 0.

■ Setting the Droop Control Delay Time

The Droop Control delay time in parameter b7-02 is used to adjust the responsiveness of droop control. Increase this setting if oscillations or hunting occur.

◆ Zero-Servo Function

The Zero-Servo function holds the motor when the motor is stopped in a so called Zero-Servo status. This means, that if the frequency reference falls below the Zero-Speed level (parameter b2-01) a position loop is activated and the motor is kept at the position, even if a load is applied.

The zero-servo function must be enabled using a digital input, which is programmed for is set to Zero-Servo command (H1-□□ = 72).

The actual deviation of the rotor position from the zero position can be monitored using parameter U1-35. The shown value must be divided by to the get the displacement in encoder pulses.

A digital output (H2-□□ = 33) can be used to signalize the completion of a Zero-Servo command. The contact is closed as long as the actual rotor position is within the zero position \pm Zero-Servo completion width.

■ Related Constants

Parameter No.	Name	Factory Setting	Change during Operation	Control Methods			
				V/f	V/f with PG	Open Loop Vector	Closed Loop Vector
b2-01	Zero speed level (DC injection braking starting frequency)	0.5 Hz	No	A	A	A	A
b9-01	Zero-servo gain	5	No	No	No	No	A
b9-02	Zero-Servo completion width	10	No	No	No	No	A

Multi-function Digital Inputs (H1-01 to H1-05)

Set Value	Function	Control Methods			
		V/f	V/f with PG	Open Loop Vector	Closed Loop Vector
72	Zero-servo command (ON: Zero-servo)	No	No	No	Yes

Multifunction Outputs (H2-01 to H2-03)

Set Value	Function	Control Methods			
		V/f	V/f with PG	Open Loop Vector	Closed Loop Vector
33	Zero-servo end ON: Current position is within zero-servo start position \pm the zero-servo end width.	No	No	No	Yes

Monitors

Parameter Number	Name	Description	Output Signal Level at Analog Output	Min. Unit	Control Methods			
					V/f	V/f with PG	Open Loop Vector	Closed Loop Vector
U1-35	Zero-servo movement pulses	Shows the number of PG pulses times 4 for the movement range when stopped at zero.	(Cannot be output.)	1	No	No	No	A

■ Timing Chart

An example timing chart for the Zero-Servo function showing the input and output signals is given in the figure below.

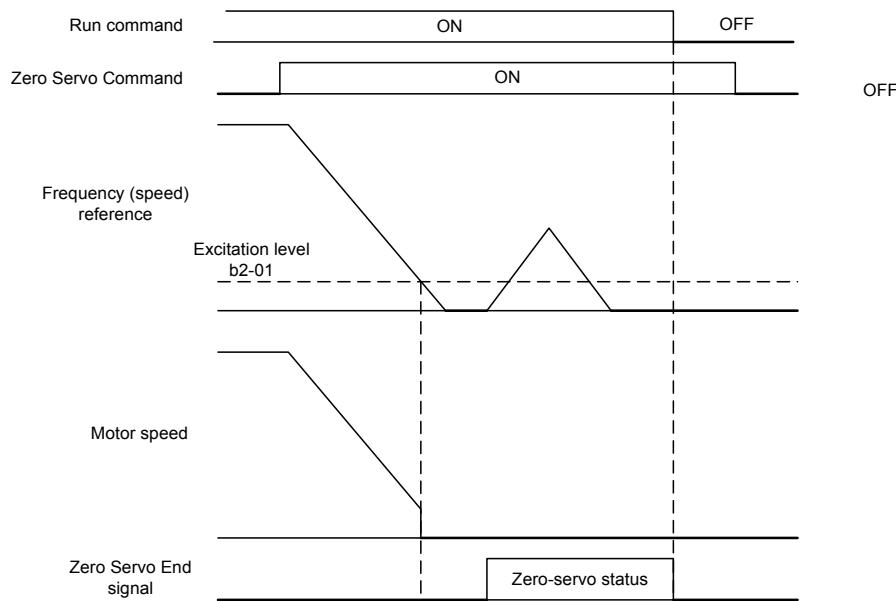

Fig 6.89 Time Chart for the Zero-Servo Function

■ Application Precautions

- Be sure to leave the run command input activated. If the run command is turned OFF, the output will be interrupted and the zero-servo function will become inactive.
- The holding force of the Zero-Servo position loop can be adjusted in parameter b9-01. The holding force will increase if the set value is increased. Oscillation and hunting may occur, if the setting is too large. Adjust b9-01 after adjusting the speed controller (ASR).
- The Zero-Servo detection width is set as the allowable displacement from the Zero-Servo start position. Set the b9-02 taking the number of displacement pulses from the PG multiplied by 4.
- The Zero-Servo completion signal will be turned OFF when the zero servo command is turned OFF.



Do not use the Zero-Servo for extended periods of time with 100% of torque. Inverter errors may result. If the Zero Servo function shall be used continuously, make sure that the output current during the servolock is 50% of the motor current or less.

◆ Kinetic Energy Buffering

The kinetic energy buffering function can be used to decelerate to stop after a sudden power loss using the kinetic energy of the rotating machine to maintain the DC bus voltage. Thereby an uncontrolled coasting of a machine can be prevented. The function can be activated using a multifunction input that i.e. can be operated by a DC bus undervoltage alarm output or by a voltage drop relay. A wiring example is shown in *Fig. 6.80*.

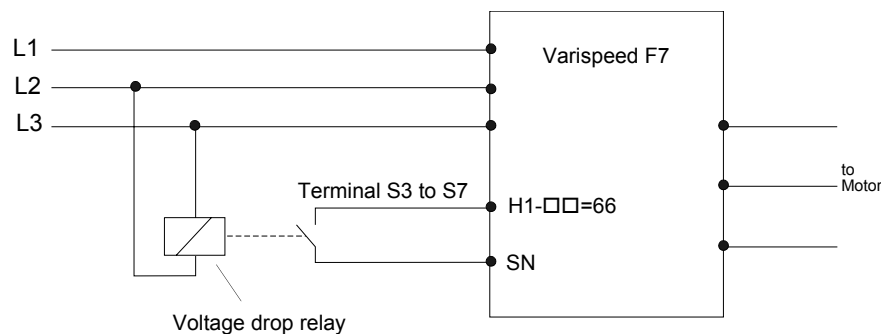

Fig 6.90 Wiring Example for KEB function usage

■ Related Parameters

Parameter No.	Name	Factory Setting	Change during Operation	Control Methods			
				V/f	V/f with PG	Open Loop Vector	Closed Loop Vector
C1-09	Fast stop time	10.0s	No	A	A	A	A
L2-01	Momentary power loss detection	0	No	A	A	A	A
L2-05	Undervoltage detection level	190 V*	No	A	A	A	A
L2-08	Frequency reduction gain at Kinetic Energy Buffering start.	100	No	A	A	A	A

* The factory setting depends upon the inverter capacity. The value for a 200 V class inverter of 0.4 kW is given.

Setting the Momentary Power Loss Detection (L2-01)

- L2-01 = 0
The inverter trips with undervoltage fault (UV1).
- L2-01 = 1
No UV1 is detected within the time which is set in parameter L2-02. If this time is exceeded and the power has not returned, an UV1 fault is output.
- No UV1 is detected. The inverter continues operation as long as the CPU is working.

To use the Kinetic Energy Buffering function in connection with the UV alarm output of the inverter, parameter L2-01 must be set to 1 or 2.

Setting the Undervoltage Level (L2-05)

This parameter sets the voltage level for the DC bus at which a DC bus undervoltage (UV, UV1) is detected. Normally there is no need to change this setting. If the UV detection is used for activating the Kinetic Energy Buffering function, the UV detection level should be increased to the maximum to detect the UV as fast as possible.

Adjusting the Kinetic Energy Buffering Deceleration Time (C1-09)

The fast stop time set in parameter C1-09 is used to decelerate to stop when a Kinetic Energy Buffering command is input.

To set up this parameter do the following:

- Increase C1-09 until a UV1 fault is detected during deceleration. (If L2-01 is set to 2, no UV1 will be detected, but the motor will start to coast when the DC bus voltage drops too much.) The highest setting value of C1-09, at which no UV1 is detected will be the maximum deceleration time.
- Decrease C1-09 until a DC bus overvoltage (OV) is detected. The lowest setting value of C1-09, at which no OV is detected, will be the minimal deceleration time.
- Set a value for C1-09, that is somewhere in the middle between the maximum and the minimum deceleration time.

Adjusting the Frequency Reduction Gain at Kinetic Energy Buffering Start (L2-08)

When the Kinetic Energy Buffering function is enabled, the output frequency is reduced for a certain frequency amount in order to prevent an UV1 fault. The amount of this frequency step can be set using parameter L2-08. It is set in percent of the slip frequency before the Kinetic Energy Buffering signal was input. Normally there is no need to change this setting.

- Increase the setting if an undervoltage fault occurs right after Kinetic Energy Buffering start.
- Decrease the setting if an overvoltage fault occurs right after Kinetic Energy Buffering start.

■ Multifunction Input Settings: H1-01 to H1-05 (Terminal S3-S7)

Kinetic Energy Buffering Command NC: "65"

- Storing this setting for one of the parameters H1-01 to H1-05, the Kinetic Energy Buffering function can be activated using a NC contact.

Kinetic Energy Buffering Command NO: "66"

- Using this setting for one of the parameters H1-01 to H1-05, the Kinetic Energy Buffering function can be activated using a NO contact.

◆ High Slip Braking (HSB)

If the load inertia is large the high slip braking function can be used to shorten the deceleration time compared to the normal deceleration time without using a braking option (braking resistor, braking resistor unit).

The function must be activated by a multifunction input. It is not comparable with the normal deceleration function. It does not use a ramp function.

HSB should not be used at normal operation instead of a deceleration ramp.

■ Related Parameters

Parameter No.	Name	Factory Setting	Change during Operation	Control Methods			
				V/f	V/f with PG	Open Loop Vector	Closed Loop Vector
N3-01	High-slip braking deceleration frequency width	5%	No	A	A	No	No
N3-02	High-slip braking current limit	150%	No	A	A	No	No
N3-03	High-slip braking stop dwell time	1.0 s	No	A	A	No	No
N3-04	High-slip braking OL time	40 s	No	A	A	No	No

Multi-function Digital Inputs (H1-01 to H1-05)

Set Value	Function	Control Methods			
		V/f	V/f with PG	Open Loop Vector	Closed Loop Vector
68	High Slip Braking command (ON: HSB activated)	Yes	Yes	No	No

■ Adjusting the HSB Deceleration Frequency Width (N3-01)

This parameter sets the step value that is used for lowering the output frequency to achieve a large negative slip and thereby to brake the motor.

Normally no adjustments is necessary. Increase the value if a DC bus overvoltage faults occur.

■ Adjusting the HSB Current Limit (N3-02)

The setting of parameter N3-02 limits the output current while high slip braking is active. The current limit affects the achievable deceleration time.

The lower the current limit the longer is the deceleration time.

■ Setting the HSB Dwell Time at Stop (N3-03)

At the end of a high slip braking the output frequency is held at the minimum output frequency for the time set in N3-03. Increase the time if the motor coasts after HSB.

■ Setting the HSB Overload Time (N3-04)

N3-04 sets the HSB overload time. If the output frequency does not change for any reason although an HSB command is given, an OL7 fault will be displayed and the fault contact will operate.

■ Activating High Slip Braking

If one of the multifunction inputs is set to “68” it can be used to activate the HSB function. The inverter will brake the motor immediately after the HSB command was given. HSB cannot be stopped, i.e. normal inverter operation cannot be resumed.

The HSB function is activated by a pulse signal, a continuous activating of the digital input is not necessary.

Digital Operator Functions

◆ Setting Digital Operator Functions

■ Related Parameters

Parameter No.	Name	Factory Setting	Change during Operation	Control Methods			
				V/f	V/fwith PG	Open Loop Vector	Closed Loop Vector
o1-01	Monitor selection	6	Yes	A	A	A	A
o1-02	Monitor selection after power up	1	Yes	A	A	A	A
o1-03	Frequency units of reference setting and monitor	0	No	A	A	A	A
o1-04	Setting unit for frequency reference related parameters	0	No	No	No	No	A
o1-05	LCD Display contrast	3	Yes	A	A	A	A
o2-01	LOCAL/REMOTE key enable/disable	1	No	A	A	A	A
o2-02	STOP key during control circuit terminal operation	1	No	A	A	A	A
o2-03	Inverter kVA selection	0*	No	A	A	A	A
o2-04	User parameter initial value	0	No	A	A	A	A
o2-05	Frequency reference setting method selection	0	No	A	A	A	A
o2-06	Operation selection when digital operator is disconnected	0	No	A	A	A	A
o2-07	Cumulative operation time setting	0	No	A	A	A	A
o2-08	Cumulative operation time selection	0	No	A	A	A	A
o2-09	Initialize Mode	2	No	A	A	A	A
o2-10	Fan operation time setting	0	No	A	A	A	A
o2-12	Fault trace initialize	0	No	A	A	A	A
o2-13	kWh monitor initialize	0	No	A	A	A	A

* Depends on the inverter capacity

■ Monitor Selection (o1-01)

Using parameter o1-01 the third monitor item that is displayed in drive mode can be selected. This function has no effect on the optional LCD-operator (JVOP-160).

■ Monitor Display when the Power Supply is Turned ON (o1-02)

Using parameter o1-02 the monitor item (U1-□□) that is to be displayed on the Digital Operator when the power supply is turned ON can be selected.

■ Changing Frequency Reference and Display Units (o1-03)

Set the Digital Operator frequency reference and display units using parameter o1-03. The setting in o1-03 will affect the display units of the following monitor items:

- U1-01 (Frequency Reference)
- U1-02 (Output Frequency)
- U1-05 (Motor Speed)
- U1-20 (Output Frequency after Soft Start)
- d1-01 to d1-17 (Frequency references)

■ Changing the Units for Frequency Parameters Related to V/f settings (o1-04)

Using parameter o1-04 the unit for frequency parameters related to the V/f setting can be changed. If o1-04 is set to 0 it will be Hz. If o1-04 is set to 1 it will be rpm.

■ Changing the Display Contrast (o1-05)

Using o1-05 the contrast of the LCD display on the digital operator can be raised or lowered. Lowering the o1-05 value will decrease the contrast and vice versa.

■ Disabling the LOCAL/REMOTE Key (o2-01)

Set o2-01 to 0 to disable the LOCAL/REMOTE Key on the Digital Operator.

If the key is disabled, it cannot be used anymore to switch over the frequency reference source or the RUN command source between LOCAL and REMOTE.

■ Disabling the STOP Key (o2-02)

This parameter is used to set whether the STOP key on the operator is active during remote control (b1-02 ≠ 0) or not.

If o2-02 is set to 1, a STOP command from the operators STOP key will be accepted. If o2-02 is set to 0 it will be disregarded.

■ Initializing Changed Parameter Values (o2-03)

You can save the current Inverter parameter setting values as user-set parameter initial values. Therefore parameter o2-03 has to be set to 1.

To initialize the Inverter parameters using the user-set initial values in memory set parameter A1-03 to 1110. To clear the user-set initial values in memory, set o2-03 to 2.

■ Changing the Inverter Capacity Setting (o2-04)

The inverter capacity setting can be set using parameter o2-04. Refer to [page 5-72, Factory Settings that Change with the Inverter Capacity \(o2-04\)](#) to see parameters that depend on this setting.

Normally it not necessary to change this setting, unless the control card has been changed.

■ Setting the Frequency Reference using the UP and DOWN Keys without Using the Enter Key (o2-05)

This function is active when frequency references are input from the Digital Operator. When o2-05 is set to 1, you can increment and decrement the frequency reference using the UP and DOWN keys without using the Enter key.

■ Operation Selection when the Digital Operator is Disconnected (o2-06)

This function selects the operation when the digital operator gets disconnected when a RUN command is active.

If o2-06 is set to 0 the operation is continued.

If o2-06 is set to 1 the output is switched off and the motor coasts to stop. The fault contact is operated. When the operator is reconnected an OPR (Operator disconnected) is shown.

■ Cumulative Operation Time (o2-07 and o2-08)

The inverter has a function that counts the operation time of the inverter cumulatively.

Using parameter o2-07 the cumulative operation time can be changed, e.g. after a replacement of the control board. If parameter o2-08 is set to 0 the inverter counts the time whenever the power supply is switched ON. If o2-08 is set to 1 the time when a RUN command is active is counted only. The factory setting is 0.

■ Cooling Fan Operation Time (o2-10)

This function counts the operating time of the inverter mounted fan cumulatively.

Using parameter o2-10 the counter can be reset, e.g. when the fan was replaced.

■ Fault Trace Initialize (o2-12)

This function can be used to initialize the fault trace by setting parameter o2-12 to 1.

■ kWh Monitor Initialize (o2-14)

Using this parameter the kWh monitor (U1-29 and U1-30) can be initialized.

◆ Copying Parameters

The Digital Operator can perform the following three functions using a built-in EEPROM (non-volatile memory).

- Store Inverter parameter set values in the Digital Operator by setting o3-01 to 1 (READ)
- Write parameter set values stored in the Digital Operator to the Inverter by setting o3-01 to 2 (COPY)
- Compare parameter set values stored in the Digital Operator with Inverter parameters settings by setting o3-01 to 3 (VERIFY)

The data saved in the operator can be protected from overwriting by setting parameter o3-02 to 0. In the case a READ command can not be executed. If it is nevertheless still done, “PrE” will be displayed at the operator.

■ Related Parameters

Parameter No.	Name	Factory Setting	Change during Operation	Control Methods			
				V/f	V/f with PG	Open Loop Vector	Closed Loop Vector
o3-01	Copy function selection	0	No	A	A	A	A
o3-02	Read permitted selection	0	No	A	A	A	A

■ Storing Inverter set values in the Digital Operator (READ)

To store Inverter set values in the Digital Operator use the following method.

Step No.	Explanation	Digital Operator Display
1	Press the Menu Key and select advanced programming mode.	-ADV- ** Main Menu ** ----- Programming
2	Press the DATA/ENTER Key.	-ADV- Initialization A1 - 00=1 ----- Select Language
3	Press the Increment and Decrement Key until parameter o3-01 is displayed (Copy Function Selection).	-ADV- COPY Function o3 - 01=0 ----- Copy Functio Sel
4	Press the DATA/ENTER Key and select the constants setting display.	-ADV- Copy Function Sel o3-01= 0 *0* ----- COPY SELECT
5	Change the set value to 1 using the Increment Key.	-ADV- Copy Function Sel o3-01= 1 *0* ----- INV → OP READ
6	Set the changed data using the DATA/ENTER Key. The READ function will start.	-ADV- READ INV → OP READING
7	If the READ function ends normally, “End” is displayed on the Digital Operator.	-ADV- READ READ COMPLETE
8	The display returns to o3-01 when a key is pressed.	-ADV- Copy Function Sel o3 - 01=0 *0* ----- COPY SELECT

If an error is displayed, press any key to cancel the error display and return to the o3-01 display. Refer to [page 7-15, Digital Operator Copy Function Faults](#) for corrective actions.

■Writing Parameter Set Values Stored in the Digital Operator to the Inverter (COPY)

To write parameter set values stored in the Digital Operator to the Inverter, use the following method.

Step No.	Explanation	Digital Operator Display
1	Press the MENU Key and select advanced programming mode.	-ADV- ** Main Menu ** ----- Programming
2	Press the DATA/ENTER Key.	-ADV- Initialization ----- A1 - 00 = 1 Select Language
3	Press the Increment and Decrement Key until parameter o3-01 is displayed (Copy Function Selection).	-ADV- COPY Function ----- o3 - 01 = 0 Copy Funtion Sel
4	Press the DATA/ENTER Key and select the constants setting display.	-ADV- Copy Function Sel ----- o3-01= 0 *0* COPY SELECT
5	Change the set value to 2 using the Increment Key.	-ADV- Copy Function Sel ----- o3-01= 2 *0* OP → INV WRITE
6	Set the changed data using the DATA/ENTER Key. The COPY function will start.	-ADV- COPY OP → INV COPYING
7	If the COPY function ends normally, “End” is displayed on the Digital Operator.	-ADV- COPY COPY COMPLETE
8	The display returns to o3-01 when a key is pressed.	-ADV- Copy Function Sel ----- o3 - 01=0 *0* COPY SELECT

If an error is displayed, set the parameters again. Refer to [page 7-15, Digital Operator Copy Function Faults](#) for corrective actions.

■ Comparing Inverter Parameters and Digital Operator Parameter Set Values (VERIFY)

To compare Inverter parameters and Digital Operator parameter set values, use the following method.

Step No.	Explanation	Digital Operator Display
1	Press the MENU Key. and select advanced programming mode.	-ADV- ** Main Menu ** ----- Programming
2	Press the DATA/ENTER Key.	-ADV- Initialization A1 - 00 = 1 ----- Select Language
3	Press the Increment and Decrement Key until the parameter o3-01 is displayed (Copy Function Selection).	-ADV- COPY Function o3 - 01=0 ----- Copy Functon Sel
4	Press the DATA/ENTER Key and select the function setting display.	-ADV- Copy Function Sel o3-01=0 *0* ----- COPY SELECT
5	Change the set value to 3 using the Increment Key.	-ADV- Copy Functon Sel o3-01=3 *0* ----- OP ↔ INV VERIFY
6	Set the changed data using the DATA/ENTER Key. The VERIFY function will start.	-ADV- VERIFY DATA VERIFYING
7	If the VERIFY function ends normally, “End” is displayed on the Digital Operator.	-ADV- VERIFY VERIFY COMPLETE
8	The display returns to o3-01 when a key is pressed.	-ADV- Copy Function Sel o3 - 01 = 0 *0* ----- COPY SELECT

If an error is displayed, press any key to cancel the error display and return to the o3-01 display. Refer to [page 7-15, Digital Operator Copy Function Faults](#) for corrective actions.



INFO

When using the copy function, check that the following settings are the same between the Inverter data and the Digital Operator data.

- Inverter product and type
- Software number
- Inverter capacity and voltage class
- Control method

◆ Prohibiting Overwriting of Parameters

If A1-01 is set to 0, all parameters except A1-01 and A1-04 are write protected, U1-□□, U2-□□ and U3-□□ will be displayed. If A1-01 is set to 1, only the parameters A1-01, A1-04 and A2-□□ can be read or written, U1-□□, U2-□□ and U3-□□ will be displayed. All other parameters will not be displayed.

If you set one of the parameters H1-01 to H1-05 (digital input terminal S3 to S7 function selection) to 1B (write parameters permitted), parameters can be written from the digital operator when the terminal that has been set is ON. When the set terminal is OFF, writing parameters other than the frequency reference is prohibited. However, the parameters can be read.

■ Related Parameters

Parameter No.	Name	Factory Setting	Change during Operation	Control Methods			
				V/f	V/fwith PG	Open Loop Vector	Closed Loop Vector
A1-01	Parameter access level	2	Yes	A	A	A	A

◆ Setting a Password

When a password is set in A1-05 and if the set values in A1-04 and A1-05 do not match, only the settings of parameters A1-01 to A1-03, or A2-01 to A2-32 can be modified.

The setting of all parameters except A1-00 can be prohibited using the password function in combination with setting parameter A1-01 to 0 (Monitor only).

■ Related Parameters

Parameter No.	Name	Factory Setting	Change during Operation	Control Methods			
				V/f	V/fwith PG	Open Loop Vector	Closed Loop Vector
A1-01	Parameter access level	2	No	A	A	A	A
A1-04	Password	0	No	A	A	A	A
A1-05	Password setting	0	No	A	A	A	A

■ Setting a Password

The password can be set in parameter A1-05. Normally A1-05 is not displayed. To display and modify A1-05 the MENU and Reset key must be pressed together in the A1-04 display.

◆ Displaying User-set Parameters Only

The A2 parameters (user-set parameters) and A1-01 (parameter access level) can be used to establish a parameter set that contains only the most important parameters.

Set the number of the parameter to which you want to refer in A2-01 to A2-32, and then set A1-01 to 1. Using the advanced programming mode you can read and modify A1-01 to A1-03 and the parameters set in A2-01 to A2-32 only.

■ Related Parameters

Parameter No.	Name	Factory Setting	Change during Operation	Control Methods			
				V/f	V/fwith PG	Open Loop Vector	Closed Loop Vector
A2-01 to A2-32	User setting parameters	-	No	A	A	A	A

Option Cards

◆ Using PG Feedback Option Cards

To get a more precise speed control the inverter can be equipped with a PG option card to connect a pulse generator. Two different PG cards can be used, the PG-B2 and the PG-X2. Refer to [page 2-28, Option Card Models and Specifications](#) to see details.

■ Related Parameters

Parameter No.	Name	Factory Setting	Change during Operation	Control Methods			
				V/f	V/f with PG	Open Loop Vector	Closed Loop Vector
F1-01	PG constant	1024	No	No	Q	Q	Q
F1-02	Operation selection at PG open circuit (PGO)	1	No	No	A	No	A
F1-03	Operation selection at overspeed (OS)	1	No	No	A	No	A
F1-04	Operation selection at deviation (DEV)	3	No	No	A	No	A
F1-05	PG rotation	0	No	No	A	A	A
F1-06	PG division rate (PG pulse monitor)	1	No	No	A	A	A
F1-07	Integral value during accel/decel enable/disable	0	No	No	A	No	A
F1-08	Overspeed (OS) detection level	115%	No	No	A	No	A
F1-09	Overspeed detection delay time (OS)	1.0 s	No	No	A	No	A
F1-10	Excessive speed deviation (DEV) detection level	10%	No	No	A	No	A
F1-11	Excessive speed deviation detection delay time (DEV)	0.5 s	No	No	A	No	A
F1-12	Number of PG gear teeth 1	0	No	No	A	No	A
F1-13	Number of PG gear teeth 2	0	No	No	A	No	A
F1-14	PG open-circuit detection delay time	2.0 s	No	No	A	No	A

■ Using PG Speed Control Card

There are two types of PG Speed Control Card that can be used in V/f control with PG and Closed Loop Vector control:

- PG-B2: A/B-phase pulse input, compatible with complementary outputs.
- PG-X2: A/B/Z-phase pulse input, compatible with line drivers (RS-422).

For the mounting instructions, specifications and connection diagrams refer to [page 2-28, Installing and Wiring Option Cards](#).



If Open Loop Vector control is used and a PG card is installed, the speed detected by the PG card is displayed in the monitor parameter U1-05. Therefore the PG constant has to be set in parameter F1-01. The direction of the speed detection can be changed by parameter F1-05. To change the U1-05 value to the internally calculated value remove the PG card.

■ Setting Number of PG Pulses (F1-01)

Set the number of PG (Pulse Generator/Encoder) pulses in pulses per revolution.

■Suit the PG Rotation Direction and Motor Rotation Direction (F1-05)

Parameter F1-05 suits the PG rotation direction to the motor rotation direction. If the motor is rotating forwards, set whether it is A-phase leads or B-phase leads.

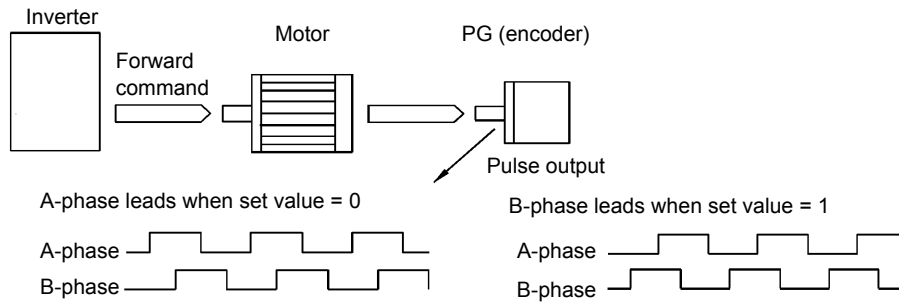

Example: Forward rotation of standard motor (PG)

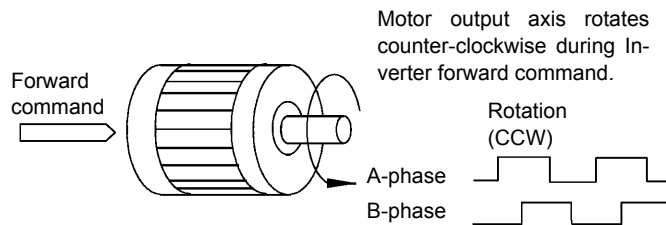

With the used PG the A-phase leads (CCW) when motor rotation is forward.

Generally, the A-phase leads when the rotation direction is counter-clockwise (CCW) seen from the shaft side (FWD command is input).

■Setting Number of Gear Teeth Between PG and Motor (F1-12 and F1-13)

If there are gears between the motor and PG, the gear ratio can be set using F1-12 and F1-13.

When the number of gear teeth has been set, the number of motor rotations within the Inverter is calculated using the following formula.

No. of motor rotations (r/min.) = No. of input pulses from PG \times 60 / F1-01 \times F1-13 (No. of gear teeth on PG side) / F1-12 (No. of gear teeth on motor side)

■Integral Operation During Acceleration and Deceleration (F1-07)

You can select whether to enable or disable integral operation during acceleration and deceleration.

To make the motor speed matching the frequency reference as closely as possible even during acceleration and deceleration, set F1-07 to 1. Refer also to [page 6-36, Automatic Speed Regulator \(ASR\)](#).



If F1-07 is set to 1, overshoot or undershoot may occur easily immediately after acceleration and deceleration. To minimize the possibility of overshoot or undershoot occurring, set F1-07 to 0.

■ Setting PG Pulse Monitor Output Dividing Ratio (F1-06)

This function is enabled only when using PG speed control card PG-B2. Set the dividing ratio for the PG pulse monitor output. The set value is expressed as n for the higher place digit, and m for the two lower place digits. The dividing ratio is calculated as follows:

Dividing ratio = $(1 + n)/m$ (Setting range) n: 0 or 1, m: 1 to 32

$$F1-06 = \frac{\square}{n} \frac{\square\square}{m}$$

The dividing ratio can be set within the following range: $1/32 \leq F1-06 \leq 1$. For example, if the dividing ratio is 1/2 (set value 2), half of the number of pulses from the PG are output at the pulse monitor.

■ Detecting PG Open Circuit (F1-02 and F1-14)

Parameter F1-02 selects the stopping method when a PG disconnection is detected.

PG open (PGO) is only detected when the inverter is running at least with a frequency reference higher than 1% of the maximum output frequency or above the minimum frequency (E1-09) and the PG feedback signal is missing for the time set in F1-14 or longer.

■ Detecting Motor Overspeed (F1-03, F1-08 and F1-09)

An overspeed (OS) is detected when the motor speed continues to exceed the set frequency value in F1-08 for a time longer than set in F1-09. After detecting an overspeed (OS), the Inverter stops according to the setting in F1-03.

■ Detecting Speed Difference between the Motor and Speed Reference (F1-04, F1-10 and F1-11)

Speed deviation is detected when the speed deviation (i.e., the difference between the speed reference and the actual motor speed) is too large. Speed deviation (DEV) is detected only after a speed agreement (speed reference and actual motor speed are within the setting range of L4-02) and if a speed deviation higher than the set value in F1-10 continues for longer than the time set in F1-11. After a speed deviation is detected, the Inverter stops according to the setting in F1-04.

◆ Analog Reference Cards

When using a AI-14B or A1-14U analog reference card, set parameter b1-01 (Reference selection) to 3 (Option Card).

The AI-14B provides 3 bi-polar input channels with 14-bit (plus sign) A/D conversion.

If b1-01 is set to 1 and F2-01 is set to 0, the channel 1 and 2 replace the analog inputs A1 and A2. A1 becomes the frequency reference input and the function of A2 can be selected using parameter H3-09. In this case no digital input can be set for the Option/Inverter selection function (H1-□□ = 2).

If b1-02 is set to 3 and F2-01 is set to 1, the sum of three input channels becomes the frequency reference value.

The AI-14U provides 2 unipolar inputs channels with 14-bit A/D conversion. Channel 1 is a voltage input and channel 2 is a current input. The sum of the channels 1 and 2 is the frequency reference. F2-01 does not need to be set for the AI-14U option card.

■ Related Parameters

Parameter No.	Name	Factory Setting	Change during Operation	Control Methods			
				V/f	V/fwith PG	Open Loop Vector	Closed Loop Vector
b1-01	Frequency reference source selection	1	No	Q	Q	Q	Q
F2-01	Bi-polar or uni-polar input selection	0	No	A	A	A	A

◆ Digital Reference Cards

When using a DI-08 or DI-16H2 Digital Reference Card, set b1-01 (Reference selection) to 3 (Option Card).

The DI-16H2 can be used to set a frequency using a 16-bit digital reference.

The DI-08 can be used to set a frequency using a 8-bit digital reference.

■ Related Parameters

Parameter No.	Name	Factory Setting	Change during Operation	Control Methods			
				V/f	V/fwith PG	Open Loop Vector	Closed Loop Vector
F3-01	Digital input selection	0	No	A	A	A	A
o1-03	Frequency units of reference setting and monitor	0	No	A	A	A	A

■ Selecting Input Terminal Functions for the DI-16H2 Digital Reference Card

The frequency reference from the DI-16H2 Card is determined by the setting of F3-01 and the 12/16-bit switch on the Option card. The possible settings are listed in the table below.

Terminal	Pin No.	12-bit Binary with Sign	16-bit Binary with Sign	3-digit BCD with Sign	4-digit BCD with Sign	5-digit BCD without Sign						
		F3-01 = 7 S1: 12 bit	F3-01 = 7 S1: 16 bit	F3-01 = 0 to 5 S1: 12 bit	F3-01 = 0 to 5 S1: 16 bit	F3-01 = 6 S1: 16 bit						
TC1	1	Bit 0 (2^0)	Bit 0 (2^0)	1	BDC digit 1 (0 to 9)	1	BDC digit 1 (0 to 9)	2	BDC digit 1 (2 to 9)			
	2	Bit 1 (2^1)	Bit 1 (2^1)	2		2		4				
	3	Bit 2 (2^2)	Bit 2 (2^2)	4		4		8				
	4	Bit 3 (2^3)	Bit 3 (2^3)	8		8		1				
	5	Bit 4 (2^4)	Bit 4 (2^4)	1	BDC digit 2 (0 to 9)	1	BDC digit 2 (0 to 9)	2	BDC digit 2 (0 to 9)			
	6	Bit 5 (2^5)	Bit 5 (2^5)	2		2		4				
	7	Bit 6 (2^6)	Bit 6 (2^6)	4		4		8				
	8	Bit 7 (2^7)	Bit 7 (2^7)	8		8		1				
	9	Bit 8 (2^8)	Bit 8 (2^8)	1	BDC digit 3 (0 to 9)	1	BDC digit 3 (0 to 9)	2	BDC digit 3 (0 to 9)			
	10	Bit 9 (2^9)	Bit 9 (2^9)	2		2		4				
TC2	1	Bit A (2^{10})	Bit A (2^{10})	4		BDC digit 4 (0 to 9)		4		BDC digit 4 (0 to 9)	8	BDC digit 4 (0 to 9)
	2	Bit B (2^{11})	Bit B (2^{11})	8				8			1	
	3	-	Bit C (2^{12})		-	1	BDC digit 4 (0 to 9)	2	BDC digit 4 (0 to 9)			
	4	-	Bit D (2^{13})		-	2		4				
	5	-	Bit E (2^{14})		-	4		8				
	6	-	Bit F (2^{15})		-	8		1				
	7	Sign signal (0: Forward, 1: Reverse)						2	BDC digit 5 (0 to 3)			
	8	SET (read) signal (1: Read)										
	9	Input signal common (0 V)										
TC3	Shield wire connection terminal											

■ Application Precautions

- The maximum frequency (100% speed) reference will be used when the binary input is set (setting: 6 or 7) and all bits are 1.
- Setting F3-01 to 6 is valid only when the DI-16H2 is used. Using this setting a frequency from 0.00 to 399.8 Hz can be set in BCD. The sign bit is used as a data bit, i.e. only positive data can be set. Also, the digit starts from 0, i.e. the minimum setting is 0.02 Hz.

■Selecting the Input Terminal Function for a DI-08 Digital Reference Card

The frequency reference from a DI-08 Card is determined by the setting of F3-01, as shown in the following table.

Terminal	Pin No.	8-bit Binary with Sign	2-digit BCD with Sign	
		F3-01 = 7	F3-01 = 0 to 5	
TC	1	Bit 0 (2^0)	1	BDC digit 1 (0 to 9)
	2	Bit 1 (2^1)	2	
	3	Bit 2 (2^2)	4	
	4	Bit 3 (2^3)	8	
	5	Bit 4 (2^4)	1	BDC digit 2 (0 to 15)
	6	Bit 5 (2^5)	2	
	7	Bit 6 (2^6)	4	
	8	Bit 7 (2^7)	8	
	9	Sign signal		
	10	SET (read) signal		
	11	Reference common signal (0 V)		

■Application Precautions

The DI-08 will not function if F3-01 is set to 6.

■ Selecting the Digital Reference

The setting range of the digital references is determined by the combination of the settings of o1-03 and F3-01. The information monitored in U1-01 (Frequency reference) will also change.

DI-16H2 Reference Setting Ranges

With the DI-16H2 option card setting ranges can be set like shown in table below.

o1-03	F3-01	Switch S1	Reference Input Mode	Reference Setting Range	U1-01 Monitor Unit	
					o1-03 = 0	o1-03 = 1
0 or 1	0	12 bits	3-digit BCD with sign, 1%	-110 to 110%	0.01 Hz	0.01%
		16 bits	4-digit BCD with sign, 1%	-110 to 110%		
	1	12 bits	3-digit BCD with sign, 0.1%	-110.0 to 110.0%		
		16 bits	4-digit BCD with sign, 0.1%	-110.0 to 110.0%		
	2	12 bits	3-digit BCD with sign, 0.01%	-15.99 to 15.99%		
		16 bits	4-digit BCD with sign, 0.01%	-110.0 to 110.0%		
	3	12 bits	3-digit BCD with sign, 1 Hz	-400 to 400 Hz		
		16 bits	4-digit BCD with sign, 1 Hz	-400 to 400 Hz		
	4	12 bits	3-digit BCD with sign, 0.1 Hz	-159.9 to 159.9 Hz		
		16 bits	4-digit BCD with sign, 0.1 Hz	-400.0 to 400.0 Hz		
	5	12 bits	3-digit BCD with sign, 0.01 Hz	-15.99 to 15.99 Hz		
		16 bits	4-digit BCD with sign, 0.01 Hz	-159.99 to 159.99 Hz		
	6	16 bits	5-digit BCD without sign, 0.01 Hz	000.00 to 399.98 Hz		
	7	12 bits	12-bit binary with sign, 100%/4095	-4095 to 4095		
16 bits		16-bit binary with sign, 100%/30000	-33000 to 33000			
2 to 39	-	12 bits	3-digit BCD with sign, 1 rpm	-1599 to 1599 rpm	1 rpm	
		16 bits	4-digit BCD with sign, 1 rpm	-15999 to 15999 rpm	1 rpm	
40 to 39999	-	12 bits	3-digit BCD with sign, 100%/(1- to 4-digit setting of o1-03)	-4095 to 4095	5th digit of o1-03 setting: X = 0, unit: 1 X = 1, unit: 0.1 X = 2, unit: 0.01 X = 3, unit: 0.001	
		16 bits	4-digit BCD with sign, 100%/(1- to 4-digit setting of o1-03)	-10999 to 10999 (when o1-03 = 9999)		
10000 x = 1 to 3	-	16 bits	4-digit BCD with sign, 100%/10000	-11000 to 11000		

DI-08 Reference Setting Ranges

With the DI-16H2 option card setting ranges can be set like shown in the table below.

F3-01	Reference Input Mode	Reference Setting Range	U1-01 Monitor Unit	
			o1-03 = 0	o1-03 = 1
0	2-digit BCD with sign, 1%	-110 to 110%	0.01 Hz	0.01%
1	2-digit BCD with sign, 0.1%	-15.9 to 15.9%		
2	2-digit BCD with sign, 0.01%	-1.59 to 1.59%		
3	2-digit BCD with sign, 1 Hz	-159 to 159 Hz		
4	2-digit BCD with sign, 0.1 Hz	-15.9 to 15.9 Hz		
5	2-digit BCD with sign, 0.01 Hz	-1.59 to 1.59 Hz		
6	-			
7	12-bit binary with sign, 100%/4095	-255 to 255		



7

Troubleshooting

This chapter describes the fault displays and countermeasures for Inverter and motor problems.

Protective and Diagnostic Functions.....	7-2
Troubleshooting	7-17

Protective and Diagnostic Functions

This section describes the fault and alarm functions of the Inverter. These functions include fault detection, alarm detection, operator programming error detection and auto-tuning error detection.

◆ Fault Detection

When the Inverter detects a fault, the fault contact output operates and the Inverter output is switched OFF causing the motor to coast to stop. (The stopping method can be selected for some faults.) A fault code is displayed on the Digital Operator.

When a fault has occurred refer to the following table to identify the fault and to correct the causes.

Use one of the following methods to reset the fault before restarting the Inverter:

- Set a multi-function contact input (H1-01 to H1-05) to 14 (Fault Reset) and turn ON the error reset signal.
- Press the RESET key on the Digital Operator.
- Turn the main circuit power supply OFF and then ON again.

To reset a fault it is necessary to remove the cause of the fault and the RUN signal. Only then a Reset signal is accepted.

Table 7.1 Fault Detection

Display	Meaning	Probable Causes	Corrective Actions
GF Ground Fault	Ground Fault The ground current at the Inverter output exceeded 50% of the Inverter rated output current and L8-09=1 (Enabled).	One Inverter output was shorted to ground and/or a DCCT is defective.	Remove the motor and run the Inverter without the motor.
			Check the motor for a phase to ground short.
			Check the output current with a clampmeter to verify the DCCT reading.
OC Over Current	Overcurrent The Inverter's output current exceeded the overcurrent detection level.	Shorted Inverter output phase-to-phase, shorted motor, locked rotor, load too heavy, accel/decel time too short, contactor on the Inverter output has opened or closed, a special motor or a motor with a rated current larger than the Inverter's output current is used.	Remove the motor and run the Inverter without the motor.
			Check the motor for a phase-to-phase short.
			Verify the accel/decel times (C1-□□).
			Check the Inverter for a phase-to-phase short at the output.
PUF DC Bus Fuse Open	DC Bus Fuse The fuse in the main circuit is open. Warning: Never run the Inverter after replacing the DC bus fuse without checking for shorted components.	Shorted output or terminals or damaged IGBT's.	Check the motor and the motor cables for short circuits or insulation failures (phase-to-phase).
			Replace the inverter after correcting the fault.
OV DC Bus Overvolt	DC Bus Overvoltage The DC bus voltage has exceeded the overvoltage detection level. Default detection levels are: 200 V class: 410 VDC 400 V class: 820 VDC	The deceleration time is set too short and the regenerative energy from the motor is too large.	Increase the deceleration time (C1-02/04/06/08) or connect a braking option.
		The power supply voltage is too high.	Check the power supply and decrease the voltage to meet the inverter's specifications.

Table 7.1 Fault Detection

Display	Meaning	Probable Causes	Corrective Actions
UV1 DC Bus Undervolt	DC Bus Undervoltage The DC bus voltage is below the Undervoltage Detection Level (L2-05). The default settings are: 200V class: 190 VDC 400 V class: 380 VDC	The voltage fluctuations of the power supply are too high.	Check the input voltage.
		A momentary power loss occurred.	
		The terminal screws of the input power supply are loose.	Check the wiring of the input terminals.
		An open-phase error occurred at the input terminals.	Check the input voltage and the wiring of the input terminals.
	The acceleration time is set too short.	Extend the settings in C1-01/03/05/07	
	Main Circuit MC Operation Failure The MC stopped responding during Inverter operation. (Applicable Inverter Capacities 200 V class: 37 to 110 kW 400 V class: 75 to 300 kW)	An error occurred in the inrush current prevention circuit while the Inverter was running.	Replace the Inverter.
UV2 CTL PS Undervolt	Control Power Supply Undervoltage Undervoltage of the control circuit while the Inverter was running.	External load was pulling down the Inverter's power supplies or there was an internal short in the power/gate drive board.	Remove all connection to the control terminals and cycle the power to the Inverter.
			Replace the Inverter.
UV3 MC Answerback	Inrush Current Prevention Circuit Fault An overheating of the charging resistor for the DC bus capacitors occurred. The MC of the charging circuit did not respond 10 sec. after the MC ON signal has been output. (Applicable Inverter Capacities 200 V class: 37 to 110 kW 400 V class: 75 to 300 kW)		Cycle the power to the Inverter.
		The contactor of the inrush current prevention circuit is defective.	Replace the Inverter if the fault continues to occur.
PF Input Phase Loss	Main Circuit Voltage Fault An unusual big ripple on the DC bus voltage has been detected. Only detected when L8-05=1 (enabled)	The wiring terminals for the input power supply are loose.	Tighten the input terminal screws
		A phase loss occurred in the input power supply.	Check the power supply voltage
		A momentary power loss occurred	
		The voltage fluctuations in the input power supply are too high.	
		The voltage balance between the input phases is bad.	
LF Output Phase Loss	Output Open-phase An open-phase occurred at the Inverter output. The fault is detected when the output current falls below 5% of the inverter rated current and L8-07=1 (enabled)	There is a broken wire in the output cable. There is a broken wire in the motor winding. The output terminals are loose.	Reset the fault after correcting its cause.
		The motor being used has a capacity less than 5% of the Inverter's maximum motor capacity.	Check the motor and Inverter capacity.

Table 7.1 Fault Detection

Display	Meaning	Probable Causes	Corrective Actions
OH Heatsink Overtemp	Heatsink Overheat The temperature of the Inverter's cooling fin exceeded the setting in L8-02 and L8-03 = 0 to 2.	The ambient temperature is too high.	Check for dirt build-up on the fans or heatsink.
		There is a heat source nearby.	Reduce the ambient temperature around the drive.
		The Inverter's cooling fan(s) stopped.	
	Inverter's Cooling Fan Stopped	The Inverter's internal cooling fan has stopped (18.5 kW and larger).	Replace the cooling fan(s).
OH1 Heatsink Max Temp	Heatsink Overheat The temperature of the Inverter's heatsink exceeded 105 °C.	The ambient temperature is too high.	Check for dirt build-up on the fans or heatsink.
		There is a heat source nearby.	Reduce the ambient temperature around the drive.
		The Inverter's cooling fan(s) stopped.	
	Inverter's Cooling Fan Stopped	The Inverter's internal cooling fan has stopped (18.5 kW and larger).	Replace the cooling fan(s).
OH3 Motor Overheat 1	Motor Overheating Detected when the level at A2, programmed for motor temperature (Thermistor input, H3-09=E), exceeds 1.17 V for the time L1-05 and L1-03 = 0 to 2.	Overheating of the motor was measured by the motor thermistor.	Recheck the cycle time and the size of the load.
			Recheck the accel and decel times (C1-□□).
			Recheck the V/f pattern (E1-□□).
			Recheck the motor rated current value (E2-01).
OH4 Motor Overheat 2	Motor Overheating Detected when the level at A2, programmed for motor temperature (Thermistor input, H3-09=E), exceeds 2.34 V for the time L1-05 and L1-03 = 0 to 2.	Overheating of the motor was measured by the motor thermistor.	Recheck the cycle time and the size of the load.
			Recheck the accel and decel times (C1-□□).
			Recheck the V/f pattern (E1-□□).
			Recheck the motor rated current value (E2-01).
RH DynBrk Transistr	Dynamic Braking Resistor The protection of the heatsink mounted resistor is activated when L8-01=1. This fault is only applicable when using the 3% duty cycle resistor, which is mounted on the Inverter's heatsink. For all other resistors, set L8-01=0.	Overhauling load, extended dynamic braking duty cycle, defective dynamic braking resistor.	Verify dynamic braking duty cycle (load, decel times, motor speed).
			Monitor DC bus voltage.
			Replace dynamic braking resistor.
RR DynBrk Transistr	Dynamic Braking Transistor The built-in dynamic braking transistor failed.	Defective or failed dynamic braking resistor caused braking transistor damage.	Cycle power to the Inverter.
			Replace the Inverter.

Table 7.1 Fault Detection

Display	Meaning	Probable Causes	Corrective Actions
OL1 Motor Overload	Motor Overload Detected when L1-01 = 1 to 3 and the Inverter's output current exceeded the motor overload curve.	The load is too large. The acceleration time, deceleration time or cycle time are too short.	Recheck the cycle time and the size of the load as well as the accel/decel times (C1-□□).
	The overload curve is adjustable using parameter E2-01 (Motor Rated Current), L1-01(Motor Protection Selection) and L2-02 (Motor Protection Time Constant)	The voltage settings of the V/f pattern is incorrect for the application.	Check the V/f characteristics (E1-□□).
		The setting of Motor Rated Current (E2-01) is incorrect.	Check the setting of Motor Rated Current Setting (E2-01).
OL2 Inv Overload	Inverter Overload The Inverter output current exceeded the Inverter's overload curve.	The load is too large. The acceleration time or deceleration times are too short.	Recheck the cycle time and the size of the load as well as the accel/decel times (C1-□□).
		The voltage settings of the V/f pattern is incorrect for the application.	Check the V/f characteristics (E1-□□).
		The size of the Inverter is too small.	Check the setting of Motor Rated Current Setting (E2-01).
OL3 Overtorque Det 1	Overtorque Detection 1 The Inverter's output current (V/f control) or the output torque (Vector Control) exceeded L6-02 for longer then the time set in L6-03 and L6-01 = 3 or 4.	Motor was overloaded.	Ensure the values in L6-02 and L6-03 are appropriate.
			Check application/machine status to eliminate fault.
OL4 Overtorque Det 2	Overtorque Detection 2 The Inverter's output current (V/f control) or the output torque (Vector Control) exceeded L6-05 for longer then the time set in L6-06 and L6-04 = 3 or 4.	Motor was overloaded.	Ensure the values in L6-05 and L6-06 are appropriate.
			Check application/machine status to eliminate fault.
OL7 HSB OL	High Slip Braking OL The output frequency stayed constant for longer than the time set in n3-04 during High Slip Braking.	The inertia of the load is too large.	Make sure the load is an inertial load.
			If possible, reduce the load inertia.
UL3 Undertorq Det 1	Undertorque Detection 1 The Inverter's output current (V/f control) or the output torque (Vector control) fell below L6-02 for longer then the time set in L6-03 and L6-04 = 7 or 8.	Motor was underloaded.	Ensure the values in L6-02 and L6-03 are appropriate.
			Check application/machine status to eliminate fault.
UL4 Undertorq Det 2	Undertorque Detection 2 The Inverter's output current (V/f control) or the output torque (Vector control) fell below L6-05 for longer then the time set in L6-06 and L6-04 = 7 or 8.	Motor was underloaded.	Ensure the values in L6-05 and L6-06 are appropriate.
			Check application/machine status to eliminate fault.
OS Overspeed Det	Motor Overspeed Detected when F1-03 = 0 to 2 and A1-02 = 1 or 3. The motor speed feedback (U1-05) exceeded the setting in F1-08 for a longer time than the setting in F1-09.	Overshooting/Undershooting are occurring.	Adjust the ASR settings in the C5 parameter group.
		The reference was too high.	Check the reference circuit and reference gain.
		The settings in F1-08 and F1-09 are not appropriate.	Check the settings in F1-08 and F1-09.

Table 7.1 Fault Detection

Display	Meaning	Probable Causes	Corrective Actions
PGO PG Open	PG Disconnection Detected when F1-02 = 0 to 2 and A1-02 = 1 or 3 Detected when no PG (encoder) pulses are received for a time longer than the setting in F1-14.	There is a break in the PG wiring.	Fix the broken/disconnected wiring.
		The PG is wired incorrectly.	Fix the wiring.
		Power is not being supplied to the PG.	Supply power to the PG properly.
		Wrong brake control sequence when a brake is used.	Check if the brake is opened when the RUN command is applied.
DEV Speed Deviation	Excessive Speed Deviation Detected when F1-04 = 0 to 2 and A1-02 = 1 or 3 The speed deviation is greater than the setting in F1-10 for a time longer than the setting F1-11	The load is too large.	Reduce the load.
		The acceleration time and deceleration time are too short.	Lengthen the acceleration time and deceleration time.
		The load is locked.	Check the mechanical system.
		The settings in F1-10 and F1-11 are not appropriate.	Check the settings in F1-10 and F1-11.
		Wrong brake control sequence when a brake is used.	Check if the brake is opened when the RUN command is applied.
SVE Zero Servo Fault	Zero Servo Fault The motor position moved during Zero Servo Operation.	The torque limit is too small.	Increase the torque limit.
		The load torque is too large.	Decrease the load torque.
		-	Check for signal noise.
CF Out of Control	Control Fault A torque limit was reached continuously for 3 seconds or longer during a deceleration stop in Open Loop Vector control.	Motor parameters were not set properly.	Check the motor parameters.
FBL Feedback Loss	PID Feedback Lost This fault occurs when PID feedback loss detection is programmed to fault (b5-12 = 2) and the PID feedback fell below the PID Feedback Loss Detection Level (b5-13) for the PID Feedback Loss Detection Time (b5-14)	PID feedback source (e.g. transducer, sensor, building automation signal) is not installed correctly or is not working.	Verify Inverter is programmed to receive the PID feedback source signal. Check to ensure the PID feedback source is installed and working properly.
EF0 Opt External Flt	External fault input from Communications Option Card	An external fault condition was present, input from a communication option card.	Check for an external fault condition. Verify the parameters. Verify communication signals
EF3 Ext Fault S3	External fault at terminal S3	An "external fault" was input from a multi-function input terminal (S3 to S7).	Eliminate the cause of the external fault condition.
EF4 Ext Fault S4	External fault at terminal S4		
EF5 Ext Fault S5	External fault at terminal S5		
EF6 Ext Fault S6	External fault at terminal S6		
EF 7 Ext Fault S7	External fault at terminal S7		
OPR Oper Disconnect	Digital Operator Connection Fault Detected when the digital operator is removed and the Inverter receives its RUN command through the digital operator (b1-02=0)	The digital operator was removed during running or the operator cable is broken.	Check the connection of the Digital Operator.

Table 7.1 Fault Detection

Display	Meaning	Probable Causes	Corrective Actions
CE Memobus Com Err	MEMOBUS Communication Error Detected when control data was not received correctly for two seconds and H5-04 = 0 to 2 and H5-05=1.	Connection is broken and/or the master has stopped the communication.	Check the connections and all user-side software configurations.
BUS Option Com Err	Option Communication Error After initial communication was established, the connection was lost.	Connection is broken and/or the master has stopped the communication.	Check the connections and all user-side software configurations.
CPF00 COM- ERR(OP&INV)	Digital Operator Communication Fault 1 Communication with the digital operator could not be established within 5 seconds after the power was supplied to the Inverter.	Digital operator cable was not securely connected or digital operator is defective and/or control board is defective	Disconnect the Digital Operator and then connect it again. Replace the Inverter.
	CPU External RAM Fault	The control board is damaged.	Cycle the inverter power supply, Replace the Inverter.
CPF01 COM- ERR(OP&INV)	Digital Operator Communication Fault 2 After communications with the digital operator was established, the communication stopped for 2 seconds or more.	Digital operator cable was not securely connected or digital operator is defective	Disconnect the Digital Operator and then connect it again.
		The control board is damaged.	Cycle the power to the Inverter. Replace the Inverter.
CPF02 BB Circuit Err	Baseblock circuit error A baseblock circuit error occurred at power-up.	Gate array hardware failure at power-up.	Perform an initialization to factory defaults.
			Cycle the power to the Inverter.
			Replace the Inverter.
CPF03 EEPROM Error	EEPROM error Check sum is not valid	Noise or spike was on the control circuit input terminals or the control board is damaged.	Perform an initialization to factory defaults.
			Cycle the power to the Inverter
			Replace the Inverter.
CPF04 Internal A/D Err	CPU Internal A/D Converter Fault	Noise or spike was on the control circuit input terminals or the control board is damaged.	Perform an initialization to factory defaults.
			Cycle the power to the Inverter.
			Replace the Inverter.
CPF05 External A/D Err	CPU External A/D Converter Fault	Noise or spike was on the control circuit input terminals or the control board is damaged.	Perform an initialization to factory defaults.
			Cycle the power to the Inverter.
			Replace the Inverter.
CPF06 Option Error	Option Card Connection Fault	The Option Card is not connected properly.	Turn off the power and re-install the Option Card again.
		The Inverter or Option Card is damaged	Replace the Option Card or the Inverter.
CPF07 RAM-Err	ASIC Internal RAM fault	-	Cycle the power to the Inverter
		The control circuit is damaged.	Replace the Inverter.

Table 7.1 Fault Detection

Display	Meaning	Probable Causes	Corrective Actions
CPF08 WAT-Err	Watchdog Timer Fault	-	Cycle the power to the Inverter
		The control circuit is damaged.	Replace the Inverter.
CPF09 CPU-Err	CPU-ASIC Mutual Diagnosis Fault	-	Cycle the power to the Inverter
		The control circuit is damaged.	Replace the Inverter.
CPF10 ASIC-Err	ASIC version fault	The control circuit is damaged.	Replace the Inverter.
CPF20 Option A/D Error	Communication Option Card A/D Converter Error	Option board connection is not correct.	Turn off the power and re-install the option board again
			Remove all inputs to the option board
		Option card A/D converter is faulty.	Perform an initialization to factory defaults.
			Cycle the power to the Inverter
			Replace the option board
Replace the inverter			
CPF21 Option CPU Down	Self-diagnosis Fault of Option Board	Noise or spike was on the communication line and/or defective option board.	Perform an initialization to factory defaults.
			Cycle the power to the Inverter
			Replace the option board
			Replace the Inverter
CPF22 Option Type Err	Option Board Code Number Fault	Unrecognizable option board is connected to the control board.	Remove any option boards
			Perform an initialization to factory defaults
			Cycle the power to the Inverter
			Replace the option board
			Replace the Inverter
CPF23 Option DPRAM Err	Option Board Interconnection Fault	An option board was not correctly connected to the control board, or an option board that was not made for the Inverter is attached to the control board.	Turn off the power and re-install the option board again
			Perform an initialization to factory defaults
			Cycle the power to the Inverter
			Replace the option board
			Replace the Inverter

◆ Alarm Detection

Alarms are Inverter protection function that do not operate the fault contact output. The system will automatically return to its original status when the cause of the alarm has been removed.

During an alarm condition, the Digital Operator display flashes and an alarm output is generated at the multi-function outputs (H2-01 to H2-03) if programmed

When an alarm occurs, take appropriate countermeasures according to the table below.

Table 7.2 Alarm Detection

Display	Meaning	Probable causes	Corrective Actions
EF External Fault (flashing)	Forward/Reverse Run Commands Input Together Both the forward and the reverse run commands are input simultaneously for 500ms or more. This alarm stops the motor.	The external forward and reverse command were input simultaneously.	Check external sequence logic, so only one input is received at a time.
UV DC Bus Undervolt (flashing)	DC Bus Undervoltage The following conditions occurred The DC bus voltage was below the Undervoltage Detection Level Setting (L2-05). The MC of the inrush current prevention circuit opened. The control power supply voltage was below the CUV level. UV Alarm is only detected when the drive is in a stopped condition	For the probable causes please have a look at UV1, UV2 and UV3 in table 7.1.	For the corrective actions please have a look at UV1, UV2 and UV3 in table 7.1
OV DC Bus Overvolt (flashing)	DC Bus Overvoltage The DC bus voltage exceeded the overvoltage detection level. 200 V class: 410 VDC 400 V class: 820 VDC OV Alarm is only detected when the drive is in a stopped condition	The power supply voltage is too high.	Check the power supply and decrease the voltage to meet the Inverter's specifications
OH Heatsnk Overtmp (flashing)	Heatsink Overheat The temperature of the Inverter's cooling fin exceeded the temperature programmed in L8-02. Enabled when L8-03 = 3	The ambient temperature is too high.	Check for dirt build-up on the fans or heatsink.
		There is a heat source nearby.	Reduce the ambient temperature around the Inverter
		The Inverter cooling fan(s) has stopped.	Replace the cooling fan(s).
OH2 Over Heat 2 (flashing)	Overheat Alarm An OH2 alarm signal is input from a multi-function digital input terminal (S3 to S7) that is programmed to OH2 Alarm Signal Input (H1-□□ = B)	An external overheat condition exists that was connected to one of the multi-function input terminals S3 to S7.	Check the external overheat signal connected to the specified digital input. Verify the parameter settings in H1-□□
OH3 Motor Overheat 1 (flashing)	Motor Overheating Alarm Detected when the level at A2, programmed for motor temperature (Thermistor input, H3-09 = E), exceeds 1.17 V for the time L1-05 and L1-03 = 3.	Overheating of the motor as measured by the motor thermistor.	Recheck the cycle time and the size of the load.
			Recheck the accel and decel times (C1-□□)
			Recheck the V/f pattern (E1-□□).
			Recheck the motor rated current value (E2-01)

Table 7.2 Alarm Detection

Display	Meaning	Probable causes	Corrective Actions
OL3 Overtorque Det 1 (flashing)	Overtorque Detection 1 The Inverter's output current (V/f control) or the output torque (Vector control) exceeded L6-02 for longer than the time set in L6-03 and L6-01 = 1 or 2	Motor was overloaded	Ensure the values in L6-02 and L6-03 are appropriate.
			Check application/machine status to eliminate fault.
OL4 Overtorque Det 1 (flashing)	Overtorque Detection 1 The Inverter's output current (V/f control) or the output torque (Vector control) exceeded L6-02 for longer then the time set in L6-03 and L6-01 = 1 or 2	Motor was overloaded	Ensure the values in L6-05 and L6-06 are appropriate.
			Check application/machine status to eliminate fault.
UL3 Undertorque Det 1 (flashing)	Undertorque Detection 1 The Inverter's output current (V/f control) or the output torque (Vector control) fell below L6-02 for longer then the time set in L6-03 and L6-01 = 5 or 6.	Motor was underloaded	Ensure the values in L6-02 and L6-03 are appropriate.
			Check application/machine status to eliminate fault.
UL4 Undertorque Det 2 (flashing)	Undertorque Detection 2 The Inverter's output current (V/f control) or the output torque (Vector control) fell below L6-05 for longer then the time set in L6-06 and L6-04 = 5 or 6.	Motor was underloaded	Ensure the values in L6-05 and L6-06 are appropriate.
			Check application/machine status to eliminate fault.
OS Overspeed Det (flashing)	Overspeed Alarm Detected when A1-02 = 1 or 3 and F1-03 = 3. The motor speed feedback (U1-05) exceeded the value set in F1-08 for a time longer than the setting in F1-09.	Overshooting/undershooting are occurring.	Adjust the ASR settings in the C5 parameter group.
		The reference was too high.	Check the reference circuit and reference gain.
		The settings in F1-08 and F1-09 are not appropriate.	Check the settings in F1-08 and F1-09
PGO PG Open (flashing)	PG Disconnection Detected when F1-02 = 3 and A1-02 = 1 or 3. Detected when no PG (encoder) pulses are received for a time longer than the setting in F1-14	There is break in the PG wiring.	Fix the broken/disconnected wiring.
		The PG is wired incorrectly.	Fix the wiring
		Power isn't being supplied to the PG.	Supply power to the PG properly.
DEV Speed Deviation (flashing)	Excessive Speed Deviation Detected when F1-04 = 3 and A1-02 = 1 or 3. The speed deviation is greater than the setting in F1-10 for longer than the setting in F1-11.	The load is too large.	Reduce the load.
		The acceleration time and deceleration time are too short.	Lengthen the acceleration time and deceleration time.
		The load is locked.	Check the mechanical system.
		The settings in F1-10 and F1-11 are not appropriate.	Check the settings in F1-10 and F1-11.
EF0 Opt External Flt (flashing)	Communication Option Card External Fault	An external fault condition was present, input from a communication option card.	Check for an external fault condition.
			Verify the parameters.
			Verify communication signals

Table 7.2 Alarm Detection

Display	Meaning	Probable causes	Corrective Actions
EF3 Ext Fault S3 (flashing)	External fault at terminal S3	An external fault was input from a multi-function input terminal (S3 to S7) that is programmed for external fault function that alarms only and continues to run the Inverter.	Eliminate the cause of the external fault condition
EF4 Ext Fault S4 (flashing)	External fault at terminal S4		
EF5 Ext Fault S5 (flashing)	External fault at terminal S5		
EF6 Ext Fault S6 (flashing)	External fault at terminal S6		
EF7 Ext Fault S7 (flashing)	External fault at terminal S7		
FBL Feedback Loss (flashing)	PID Feedback Lost This fault occurs when PID feedback loss detection is programmed to alarm (b5-12 = 1) and the PID feedback fell below the PID Feedback Loss Detection Level (b5-13) for the PID Feedback Loss Detection Time (b5-14)	PID feedback source (e.g. transducer, sensor, building automation signal) is not installed correctly or is not working	Verify Inverter is programmed to receive the PID feedback source signal. Check to ensure the PID feedback source is installed and working properly.
CE MEMOBUS Com Err (flashing)	MEMOBUS Communications Alarm Detected when control data was not received correctly for two seconds and H5-04 = 3 and H5-05 = 1.	Connection is broken and/or the master has stopped the communication.	Check the connections and all user-side software configurations.
BUS Option Com Err (flashing)	Option Communications Alarm After initial communication was established, the connection was lost.	Connection is broken and/or the master has stopped the communication.	Check the connections and all user-side software configurations.
DNE Drive Not Enable (flashing)	Detected when a multi-function digital input (H1-01 to H1-05) is programmed for 6A: Drive Enable. The Inverter does not have the enable command when the RUN command is applied. This alarm stops the motor.	Enable command was lost while the Inverter was running.	Check the wiring of the input terminal and the external sequence of the enable signal.
		The RUN command was applied prior to the enable signal.	Apply and maintain the enable command before applying the RUN command.
Ext Run Active Cannot Reset	Detected when a RESET command is input while the RUN command is still active	The RUN command has not been removed and a RESET command is input by digital input or by the RESET button on the digital operator.	Remove the RUN signal first and reset the error.
CALL ComCall (flashing)	Communications on Standby Communication has not yet been established.	Connection was not made properly or user software was not configured to the proper baud rate or configuration (e.g. Parity).	Check the connections and all user-side software configurations.

◆ Operator Programming Errors

An Operator Programming Error (OPE) occurs when an inapplicable parameter is set or an individual parameter setting is inappropriate. The Inverter will not operate until the parameter is set correctly; however, no alarm or fault outputs will occur. If an OPE occurs, change the appropriate parameter by checking the cause shown in Table 7.3. When OPE error is displayed, press the ENTER key to display U1-34 (OPE Detected). This monitor will display the parameter that is causing the OPE error.

Table 7.3 Operator Programming Errors

Display	Meaning	Probable Causes	Corrective Actions
OPE01 kVA Selection	Inverter kVA Setting Error	The control board was replaced and the kVA parameter (o2-04) is set incorrectly	Enter the correct kVA setting (o2-04) by referring to the table "Factory settings that change with the Inverter kVA setting" on page 5-60.
OPE02 Limit	Parameter Setting Out of Range	Parameter setting was outside of the allowable range.	Verify the parameter settings.
OPE03 Terminal	Multi-function Input Selection Error	<p>One of the following errors has been made in the multi-function input (H1-01 to H1-05) settings:</p> <ul style="list-style-type: none"> • Duplicate functions were selected. • UP/DOWN Command(10 and 11) were not selected simultaneously. • The up/down commands (10 and 11) and Accel/Decel Ramp Hold (A) were selected at the same time. • More than one of the Speed Search inputs (61, 62, 64) were set simultaneously. • External Baseblock NO (8) and External Baseblock NC (9) were selected at the same time. • The up/down commands (10 and 11) were selected while PID Control was enabled. • The Emergency Stop Command NO (15) and NC(17) are set simultaneously. • PID is enabled and UP and/or DOWN (10 / 11) command are set. • HSB (68) and KEB (65/66) command are set simultaneously. 	Verify the parameter settings in H1-□□
OPE05 Sequence Select	<p>RUN/Reference Command Selection Error</p> <p>The Reference Source Selection b1-01 and/or the RUN Source Selection parameter b1-02 are set to 3 (option board) but no option board is installed.</p>	Option board is not installed or is installed incorrectly	<p>Verify that the board is installed. Remove the power supply and re-install the option board again</p> <p>Recheck the setting of b1-01 and b1-02.</p>
OPE06 PG Opt Missing	Control method selection error	One of the control methods needing a PG feedback was selected (A1-02 = 1 or 3), but a PG option board is not installed.	Verify the control method selection in parameter A1-02 and/or the installation of the PG option board.

Table 7.3 Operator Programming Errors

Display	Meaning	Probable Causes	Corrective Actions
OPE07 Analog Selection	Multi-function Analog Input/ Pulse Train Input Error	The same function has been selected for the analog input selection and the pulse train input selection. <ul style="list-style-type: none"> • H3-09 = B and H6-01 = 1 • H3-09 = C and H6-01 = 2 b1-01 (Reference Source Selection) is set to 4 (pulse train) and H6-01 (Pulse Train Input Function Selection) is set to a value other than 0 (frequency reference).	Check the parameters b1-01, H3-09 and H6-01.
OPE08 Constant Selection	Function Selection Error	A setting has been made that is applicable with the current control method. Example: A function used only with open loop vector control was selected for V/f control.	Verify the control method and the function.
OPE09 PID Selection	PID Control Setup Error	The following settings have been made at the same time. <ul style="list-style-type: none"> • b5-01 (PID Control Mode Selection) has been set to a value other than 0. • b5-15 (PID Sleep Function Operation Level) has been set to a value other than 0. • b1-03 (Stopping Method Selection) has been set to 2 or 3. 	Check parameters b5-01, b5-15 and b1-03.
OPE10 V/f Ptn Setting	V/f Parameter Setting Error	V/f parameter settings were out of range.	Check parameters (E1-□□, E3-□□). A frequency/voltage value may be set higher than the maximum frequency/voltage.
OPE11 CarrFrq/On-Delay	Carrier Frequency Parameter Setting Error	One of the following parameter setting errors exists. <ul style="list-style-type: none"> • Carrier frequency Gain C6-05 > 6 and C6-03 (Carrier Frequency Upper Limit) < C6-04 (Carrier Frequency Lower Limit) • Upper/lower limit error in C6-03 and 04. • C6-01 = 0 and C6-02 = 2 to 6. • C6-01 = 1 and C6-02 = 7 to E. 	Check the parameter settings.
ERR EEPROM R/W Err	EEPROM write error The NV-RAM data does not match the EEPROM data.	A verification error occurred when writing EEPROM.	Cycle power to the Inverter. Do a factory initialization (A1-03)

◆ Auto-tuning Fault

Auto-tuning faults are shown below. When the following faults are detected, the fault is displayed on the digital operator and the motor coasts to stop. No fault or alarm outputs will be operated.

Table 7.4 Auto-tuning Faults

Display	Meaning	Probable causes	Corrective Actions
Er - 01 Fault	Motor data fault	There is an error in the data input for autotuning.	Check the input data.
		There is an error in the relationship between the motor output and the motor rated current.	Check the Inverter and motor capacity.
		There is an error between the no-load current setting and the input motor rated current (when auto-tuning for line-to-line resistance is performed for vector control)	Check the motor rated current and no-load current.
Er - 02 Minor Fault	Alarm	An alarm is detected during auto-tuning.	Check the input data.
			Check wiring and the machine.
			Check the load.
Er - 03 STOP key	STOP key input	The STOP key was pressed to cancel autotuning.	-
Er - 04 Resistance	Line-to-Line Resistance Fault	Autotuning was not completed in the specified time. The auto-tuning result is outside the parameter setting range.	<ul style="list-style-type: none"> • Check the input data. • Check motor wiring. • If the motor is connected to the machine, disconnect it. • If the setting of T1-03 is higher than the Inverter input power supply voltage (E1-01), change the input data.
Er - 05 No-Load Current	No-Load Current Fault		
Er - 08 Rated slip	Rated Slip Fault		
Er - 09 Accelerate	Acceleration Fault Detected only for rotating auto-tuning	The motor did not accelerate in the specified time (C1-01 + 10 sec)	<ul style="list-style-type: none"> • Increase C1-01 (Acceleration Time 1). • Increase L7-01 and L7-02 (Torque Limits) if they are low. • If the motor is connected to the machine, disconnect it.
Er - 11 Motor Speed	Motor speed Fault Detected only for rotating auto-tuning	The torque reference exceeded 100% during acceleration. Detected when A1-02 = 2 or 3 (Vector control).	<ul style="list-style-type: none"> • If the motor is connected to the machine, disconnect it. • Increase C1-01 (Acceleration Time 1). • Check the input data (particularly the number of PG pulses and the number of motor poles).
Er - 12 I-det. Circuit	Current Detection Fault	The current exceeded the motor rated current.	Check wiring of the Inverter and the mounting.
		Any of U/T1, V/T2 and W/T3 has open-phase	

Table 7.4 Auto-tuning Faults

Display	Meaning	Probable causes	Corrective Actions
Er - 13 Leakage Inductance Fault	Leakage Inductance Fault	Auto-tuning was not completed in the specified time.	Check motor wiring.
		Auto-tuning result is outside the parameter setting range.	
End - 1 V/f Over Setting	V/f Settings Alarm Displayed after auto-tuning is complete	The torque reference exceeded 100% and the no-load current exceeded 70% during auto-tuning.	Check and correct the motor settings
			If the motor and the machine are connected, disconnect the motor from the machine.
End - 2 Saturation	Motor Core Saturation Fault Displayed after auto-tuning is complete. Detected only for rotating auto-tuning	During auto-tuning, the measured values of motor iron-core saturation coefficient 1 and 2 (E2-07 and E2-08) exceeded its setting range. A temporary value was set: E2-07 = 0.75, E2-08 = 0.50	Check the input data.
			Check the motor wiring.
			If the motor and the machine are connected, disconnect the motor from the machine.
End - 3 Rated FLA Alm	Rated Current Setting Alarm Displayed after auto-tuning is complete	During auto-tuning, the measured value of motor rated current (E2-01) was greater than the set value.	Check the motor rated current value.

◆ Digital Operator Copy Function Faults

These faults can occur during the digital operator COPY function. When a fault occurs, the fault content is displayed on the operator. A fault does not activate the fault contact output or alarm output.

Table 7.5 Digital Operator Copy Function Faults

Function	Digital Operator Display	Probable Causes	Corrective Actions
READ Function	PRE READ IMPOSSIBLE	o3-01 was set to 1 to write parameter into the Digital Operator when the Operator was write-protected (o3-02 = 0).	Set o3-02 to enable writing parameters into the Operator's memory.
	IFE READ DATA ERROR	The data file read from the Inverter was of the wrong size indicating corrupted data.	Retry the READ command (o3-01 = 1).
			Check the Digital Operator's cable.
			Replace the Digital Operator.
	RDE DATA ERROR	An attempted writing of the Inverter data to the Digital Operator's EEPROM failed.	A low Inverter voltage has been detected.
			Retry the READ command (o3-01 = 1). Replace the Digital Operator.

Table 7.5 Digital Operator Copy Function Faults

Function	Digital Operator Display	Probable Causes	Corrective Actions
COPY Function	CPE ID UNMATCHED	The Inverter type or software number was different from the stored data in the digital operator	Use stored data of the same product (F7) and software number (U1-14) only.
	VAE INV. KVA UNMATCH	The capacity of the Inverter and the capacity of the stored data in the Digital Operator are different.	Use stored data for the same Inverter capacity only (o2-04).
	CRE CONTROL UNMATCHED	The control method of the Inverter and the control method of the stored data in the Digital Operator are different.	Use stored data for the same control method (A1-02).
	CYE COPY ERROR	A parameter setting written to the Inverter was different from the setting stored in the Digital Operator.	Retry the COPY function (o3-01 = 2)
	CSE SUM CHECK ERROR	Upon completion of the COPY function, the Inverter's data checksum was different than the digital operator's data checksum.	Retry the COPY function (o3-01 = 2)
Verify Function	VYE VERIFY ERROR	The set value of the digital operator and the Inverter do not match	Retry the Verify function (o3-01 = 3)

Troubleshooting

Due to parameter setting errors, faulty wiring, and so on, the Inverter and motor may not operate as expected when the system is started. If that occurs, use this section as a reference and perform the appropriate counter-measures.

If the contents of the fault are displayed, refer to [page -2, Protective and Diagnostic Functions](#).

◆ If A Parameter Cannot Be Set

Use the following information if a parameter cannot be set.

■ The display does not change when the Increment and Decrement keys are pressed.

The following causes are possible:

The Inverter is operating (drive mode).

There are some parameters that cannot be set during operation. Turn off the RUN command and then set the parameters

Parameter write enable is input.

This occurs when "Parameter Write Enable" (set value: 1B) is set for a multi-function input terminal (H1-01 to H1-05). If the Parameter Write Enable input is OFF, the parameters cannot be changed. Turn it ON and then set the parameters.

Passwords do not match. (Only when a password is set.)

If the parameter A1-04 (Password) and A1-05 (Password Setting) settings are different, the parameters for the initialize mode cannot be changed. Enter the correct password in A1-04.

If you cannot remember the password, display A1-05 (Password Setting) by pressing the Shift/RESET key and the MENU key simultaneously while in the A1-04 display. Then set the password and input the set password in parameter A1-04.

■ OPE01 through OPE11 is displayed.

The set value for the parameter is wrong. Refer to [Table 7.3](#) in this chapter and correct the settings.

■ CPF00 or CPF01 is displayed.

This is a Digital Operator communication error. The connection between the Digital Operator and the Inverter may be faulty. Remove the Digital Operator and then re-install it.

◆ If the Motor Does Not Operate Properly

The following causes are possible:

■ Ensure the Digital Operator is securely connected to the Inverter.

■ The motor does not operate when the RUN key on the Digital Operator is pressed.

The following causes are possible:

The LOCAL/REMOTE mode is not selected properly.

The status of the SEQ and the REF LEDs have to be OFF for LOCAL mode. Press the LOCAL/REMOTE key to switch between the two modes or check if there is a multi-function digital input programmed to LOCAL/REMOTE selection (H1-□□ = 1).

The Inverter is not in drive mode

If the Inverter is not in Drive mode, it will not start. Press the MENU key once and then press the DATA/ENTER key. The Inverter is now in drive mode.

The Frequency Reference is too low

If the frequency reference is set below the frequency set in E1-09 (Minimum Output Frequency), the Inverter will not operate. Raise the frequency reference to at least the minimum output frequency.

There is a multi-function analog input setting error.

If multi-function analog input H3-09 is set to 1 (frequency gain), and if no voltage (current) is input, then the frequency reference will be zero. Check to be sure that the set value and analog input value are correct.

■ The motor does not operate when an external operation signal is input.

The following causes are possible:

The Inverter is not in drive mode.

If the Inverter is not in Drive mode, it will not start. Press the MENU key once and then press the DATA/ENTER key. The Inverter is now in drive mode.

The LOCAL/REMOTE mode is not selected properly.

The status of the SEQ and the REF LEDs have to be ON for REMOTE mode. Press the LOCAL/REMOTE key to switch between the two modes or check if there is a multi-function digital input programmed to LOCAL/REMOTE selection (H1-□□ = 1).

The Frequency Reference is too low

If the frequency reference is set below the frequency set in E1-09 (Minimum Output Frequency), the Inverter will not operate. Raise the frequency reference to at least the minimum output frequency.

■ The motor stops during acceleration or when a load is connected.

The load may be too large. The motor's responsiveness limit may be exceeded if it is accelerated too rapidly by the Inverter's stall prevention function or automatic torque boost function. Increase the acceleration time (C1-01) or reduce the motor load. Also, consider increasing the motor size.

■ The motor only rotates in one direction.

"Reverse run disabled" may be selected. If b1-04 (Prohibition of Reverse Operation) is set to 1 (reverse run prohibited), the Inverter will not accept any reverse run commands.

◆ If the Direction of the Motor Rotation is Reversed

If the motor rotates in the wrong direction, the motor output wiring may be incorrect. When the Inverter operates in the forward direction, the forward direction of the motor will depend on the manufacturer and the motor type, so be sure to check the motor specification

The direction of the motor rotation can be reversed by switching two wires among U, V, and W. If using an encoder, the polarity will also have to be switched. If the Inverter is operated in V/f mode also parameter b1-04 can be used to change the rotation direction.

◆ If the Motor Stalls or Acceleration is Slow

■ The torque limit has been reached.

When a torque limit has been set in parameters L7-01 to L7-04, the output torque will be limited according these settings. Therefore the motor may not develop enough torque to accelerate or the acceleration time might be very long.

If torque limits have been set for the multi-function analog input (H3-09 = 10 to 12 or 15), check the signals.

■ The stall prevention level during acceleration is too low.

If the value set for L3-02 (Stall Prevention Level during Acceleration) is too low, the acceleration time will be increased. Check that the set value is suitable and that the load is not too large for the motor.

■ The stall prevention level during running is too low.

If the value set for L3-06 (Stall Prevention Level during Running) is too low, the motor speed and torque will be limited. Check that the set value is suitable and that the load is not too large for the motor.

■ Auto-tuning has not been performed for vector control

Vector control will not work properly if auto-tuning has not been performed. Perform auto-tuning, or set the motor parameters through calculations.

◆ If the Motor Operates at Higher Speed than the Frequency Reference

■ PID control is enabled.

If the PID control is enabled (b5-01 = 1 to 4), the Inverter output frequency will change to regulate the process variable to the desired set point. The PID can command a speed up to Maximum Output Frequency (E1-04) even though the reference is much lower.

◆ If There is Low Speed Control Accuracy Above Base Speed in Open Loop Vector Control Mode

The Inverter's maximum output voltage is determined by its input voltage. (For example, if 400 VAC is input, then the maximum output voltage will be 400 VAC). Vector control uses voltage to control the currents within the motor. If the vector control voltage reference value exceeds the Inverter output voltage capability, the speed control accuracy will decrease because the motor currents cannot be properly controlled. Use a motor with a low rated voltage compared to the input voltage, or change to Closed Loop Vector control.

◆ If Motor Deceleration is Slow

The following causes are possible:

■ The deceleration time is long even when braking resistor is connected.

The following causes are possible:

Stall Prevention During Deceleration is enabled.

When a braking resistor is connected, set parameter L3-04 (Stall Prevention Selection during Deceleration) to 0 (disabled) or 3 (with braking resistor). When this parameter is set to 1 (enabled, factory default), the stall prevention function will interfere with the braking resistor.

The deceleration time setting is too long.

Check the deceleration time setting (parameters C1-02, C1-04, C1-06, and C1-08).

Motor torque is insufficient.

If the parameters are correct and there is no overvoltage fault, then the motor's power may be insufficient. Consider increasing the motor and Inverter capacity.

The torque limit has been reached.

When a torque limit is reached (L7-01 to L7-04), the motor torque will be limited. This can cause the deceleration time to be extended. Check to be sure that the value set for the torque limit is suitable.

If a torque limit has been set for the multi-function analog input terminal A2 Function (parameter H3-09 = 10 to 12 or 15), check to be sure that the analog input value is suitable.

◆ If the Motor Overheats

The following causes are possible:

■ The load is too large.

If the motor load is too large and the torque exceeds the motor's rated torque, the motor may overheat. Reduce the loads by either reducing the load or increasing the acceleration/deceleration times. Also consider increasing the motor size.

■ The ambient temperature is too high.

The motor rating is determined by a particular ambient operating temperature range. The motor will overheat if it is run continuously at the rated torque in an environment where the maximum ambient operating temperature is exceeded. Lower the motor's ambient temperature to be within its acceptable range.

■ Auto-tuning has not been performed for vector control

Vector control may not perform efficiently if auto-tuning has not been performed. Perform auto-tuning, or set the motor parameters through hand calculations. Alternatively, change the Control Mode Selection (A1-02) to V/f Control (0 or 1).

◆ If Peripheral Devices Like PLCs or Others are Influenced by the Starting or Running Inverter

The following solutions are possible:

- Change the Inverter's Carrier Frequency Selection (C6-02) to lower the carrier frequency. This will help to reduce the amount of transistor switching noise.
- Install an Input Noise Filter at the Inverter's input power terminals.
- Install an Output Noise Filter at the Inverter's motor terminals.
- Use shielded motor cables or a conduit. Metal shields electrical noise.
- Check the grounding of the Inverter and motor.
- Separate main circuit wiring from control circuit wiring.

◆ If the Earth Leakage Breaker Operates When the Inverter is Running

The Inverter's output is pulse modulated, i.e. the output voltage consists of high frequency pulses (PWM). This high frequency signal causes a certain amount of leakage current which may cause the earth leakage breaker to operate and cut off the power supply. Change to a ground fault interrupter with a high leakage detection level (i.e., a sensitivity current of 200 mA or higher, with an operating time of 0.1 s or more), or one that incorporates high frequencies countermeasures (i.e., one designed for use with Inverters). It will also help to some extent to lower the Inverter's Carrier Frequency Selection (C6-02). In addition, remember that the leakage current increases as the cable is lengthened.

◆ If There is Mechanical Oscillation

Use the following information when there is mechanical vibration:

■ The application is making unusual sounds.

The following causes are possible:

There may be resonance between the mechanical system's natural frequency and the carrier frequency.

This is characterized by the motor running with no noise generation, but the machinery vibrates with a high-pitched whine. To prevent this type of resonance, adjust the carrier frequency with parameters C6-02 to C6-05.

There may be resonance between a mechanical system's natural frequency and the output frequency of the Inverter.

To prevent this resonance frequency use the Jump Frequency Function in parameters d3-□□, or have the driven motor and load balanced to reduce vibration.

■ Oscillation and hunting occur with V/f control

The torque compensation parameter settings may be incorrect for the machine. Adjust parameters C4-01 (Torque Compensation Gain) and C4-02 (Torque Compensation Delay Time). Decrease C4-01 carefully in steps of 0.05 and/or increase C4-02.

Furthermore the Hunting Prevention Gain (n1-02) can be increased if the problems occur in light load conditions and the Slip Compensation Delay Time (C3-02) can be decreased.

■ Oscillation and hunting occur with V/f w/PG control.

The parameter settings of the speed control loop (Automatic Speed Regulator, ASR) may be incorrect for the machine. Adjust the gains and integral times.

If the oscillation cannot be eliminated in this way, set the hunting prevention selection (n1-01) to disabled (setting 0) and then try adjusting the gain again.

■ Oscillation and hunting occur with Open Loop Vector control.

The torque compensation parameter settings may be incorrect for the machine. Adjust parameters C4-01 (Torque Compensation Gain), C4-02 (Torque Compensation Delay Time Parameter) and C3-02 (Slip Compensation Delay Time) in order. Lower the gain parameters and raise the delay time parameters.

If auto-tuning has not been performed, proper performance may not be achieved for Vector Control. Perform auto-tuning or set the motor parameters through hand calculations. Alternatively, change the Control Mode Selection to V/f Control (A1-02 = 0 or 1)

■ Oscillation and hunting occur with Closed Loop Vector control

The gain adjustment may be insufficient. Adjust the speed control loop (Automatic Speed Regulator, ASR) by changing C5-01 (ASR Proportional Gain). If the oscillation points overlap with those of the machine and cannot be eliminated, increase the ASR Delay Time, and then readjust the ASR gain (C5-01)

If auto-tuning has not been performed, proper performance may not be achieved for Closed Loop Vector Control. Perform auto-tuning or set the motor parameters through hand calculations. Alternatively, change the Control Mode Selection to V/f Control (A1-02 = 0 or 1).

■ **Oscillation and hunting occur with PID control.**

If there is oscillation or hunting during PID control, check the oscillation cycle and individually adjust P, I, and D parameters. (Refer to [page -96, Using PID Control.](#))

◆ **If the Motor Rotates Even When Inverter Output is Stopped**

If the motor rotates after a deceleration when the Inverter is stopped due to a large inertial load, DC-injection braking may be necessary. Adjust the DC injection braking as follows.

- Increase parameter b2-02 (DC Injection Braking Current).
- Increase parameter b2-04 (DC Injection Braking Time at Stop).

◆ **If Output Frequency Does Not Rise to Frequency Reference**

■ **The frequency reference is within the jump frequency range.**

When the jump frequency function is used, the output frequency does not change within the jump frequency range. Check to be sure that the Jump Frequency (d3-01 to d3-03) and Jump Frequency Width (d3-04) settings are suitable.

■ **The frequency reference upper limit has been reached.**

The output frequency upper limit is determined by the following formula:

$$\text{Freq Ref Upper Limit} = \text{Max. Output Frequency (E1-04)} \times \text{Frequency Reference Upper Limit (d2-01)} / 100$$

Check to be sure that the parameter E1-04 and d2-01 settings are suitable.



7





8

Maintenance and Inspection

This chapter describes basic maintenance and inspection for the Inverter.

[Maintenance and Inspection](#)8-2

Maintenance and Inspection

◆ Periodic Inspection

Check the following items during periodic maintenance.

- The motor should not vibrate or make unusual noises.
- There should be no abnormal heat generation from the Inverter or motor.
- The ambient temperature should be within the Inverter's specifications.
- The output current value shown in U1-30 should not be higher than the motor or the Inverter rated current for extended period of time.
- The cooling fan in the Inverter should be operating normally.

Before attempting any maintenance checks, make sure that the three-phase power is disconnected. With power removed from the unit, the DC bus capacitors will stay charged for several minutes. The Charge LED in the Inverter will glow red until the DC bus voltage is below 10VDC. To ensure that the DC bus is completely discharged, measure between the positive and negative bus with a DC voltmeter set to the highest scale. Be sure not to touch terminals immediately after the power has been turned off. Doing so can result in electric shock.

Item	Inspection	Corrective Procedure
External terminals Mounting bolts Connectors	Are all screws and bolts tight?	Tighten loose screws and bolts firmly.
	Are connectors tight?	Reconnect the loose connectors.
Cooling fins	Are the fins dirty or dusty?	Clean off any dirt and dust with an air gun using dry air at a pressure of 4×10^5 to 6×10^5 Pa (4 to 6 bar, 55 to 85 psi).
All PCBs	Is there any conductive dirt or oil mist on the PCBs?	Clean off any dirt and dust with an air gun using dry air at a pressure of 4×10^5 to 6×10^5 Pa (4 to 6 bar, 55 to 85 psi). Replace the boards if they cannot be made clean.
Input Diodes Output Transistors Power Modules	Is there any conductive dirt or oil mist on the modules or components?	Clean off any dirt and dust with an air gun using dry air at a pressure of 4×10^5 to 6×10^5 Pa (4 to 6 bar, 55 to 85 psi).
DC bus capacitors	Are there any irregularities, such as discoloration or odor?	Replace the capacitor or Inverter.

Apply power to the Inverter and conduct the following inspection:

Item	Inspection	Corrective Procedure
Cooling Fan(s)	Is there any abnormal noise or vibration, or has the total operating time exceeded 20,000 hours. Check U1-40 for the elapsed cooling operation time.	Replace Cooling Fan

◆ Periodic Maintenance of Parts

In order to keep the Inverter operating normally over a long period of time, and to prevent down time due to an unexpected failure, it is necessary to perform periodic inspections and replace parts according to their service life.

The data indicated in the following table is to be used as a general guideline only. Periodic inspection standards vary depending on the Inverter's installation environment conditions and usage. The Inverter's suggested maintenance periods are noted below.

Part	Standard Replacement Period	Replacement Method
Cooling fan(s)	2 to 3 years (20,000 hours)	Replace with new part.
DC bus capacitor	5 years	Replace with new part. (Determine need by inspection.)
Soft charge contactor	–	Determine need by inspection.
DC bus fuse Control power fuse	10 years	Replace with new part.
PCB capacitors	5 years	Replace with new board. (Determine need by inspection.)

Note: The standard replacement period is based on the following usage conditions:

Ambient temperature: Yearly average of 30°C/86°F
Load factor: 80% maximum
Operating rate: 12 hours maximum per day

◆ Cooling Fan Replacement

■ 200 V and 400 V Class Inverters of 18.5 kW or Less

A cooling fan is attached to the bottom of the Inverter.

If the Inverter is installed using the mounting holes on the back of the Inverter, the cooling fan can be replaced without removing the Inverter from the installation panel.

If the Inverter is mounted with the heatsink external to the enclosure, the cooling fan can only be replaced by removing the Inverter from the enclosure.

Removing the Cooling Fan

1. Always turn OFF the input power before removing and installing the heatsink cooling fan.
2. Press in on the right and left sides of the fan cover in the direction of arrows "1" and when pull the fan out in the direction of arrow "2".
3. Pull out the cable connected to the fan from the fan cover and disconnect the power connector.
4. Open the fan cover on the left and right sides in direction of arrows "3" and remove the fan cover from the fan.

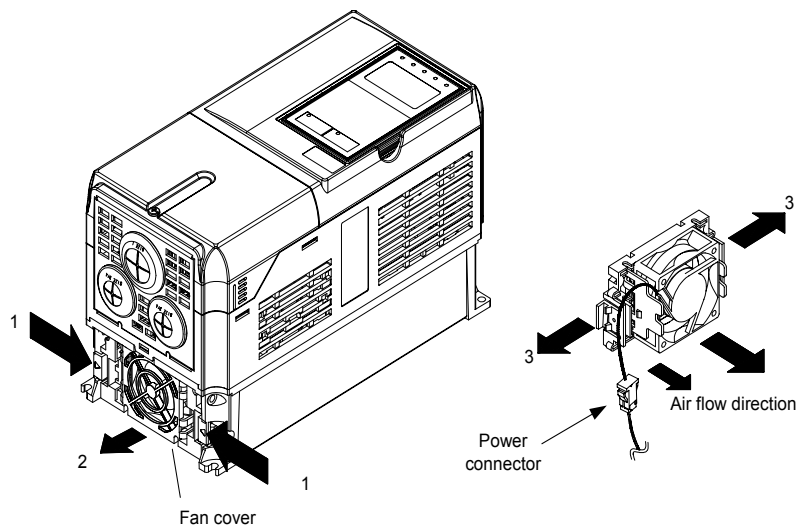

Fig 8.1 Cooling Fan Replacement (Inverters of 18.5 kW or Less)

Mounting the Cooling Fan

1. Attach the fan cover to the cooling fan. Be sure that the air flow direction is correct (see figure above).
2. Connect the cables securely and place the connector and cable into the fan cover.
3. Mount the fan cover on the Inverter. Be sure that the tabs on the sides of the fan cover click into place on the Inverter heatsink.

■200 V and 400 V Class Inverters of 22 kW or More

The heatsink cooling fan is attached to the top of the heatsink inside the Inverter. The cooling fan(s) can be replaced without removing the Inverter from the installation panel.

Removing the Cooling Fan

1. Always turn OFF the input power before removing and installing the heatsink cooling fan assembly.
2. Remove the terminal cover, Inverter cover, Digital Operator, and front cover from the Inverter.
3. Remove the control PCB (if necessary) bracket to which the cards are mounted. Remove all cables connected to the control PCB and remove the cooling fan power connector from the fan board positioned near the top of the Inverter.
4. Remove the cooling fan power connectors from the gate drive board positioned at the back of the Inverter.
5. Remove the fan assembly screws and pull out the fan assembly from the Inverter.
6. Remove the cooling fan(s) from the fan assembly.

Mounting the Cooling Fan

After attaching the new cooling fan(s), reverse the above procedure to attach all of the components. When attaching the cooling fan to the mounting bracket, be sure that the air flow direction faces the top of the Inverter.

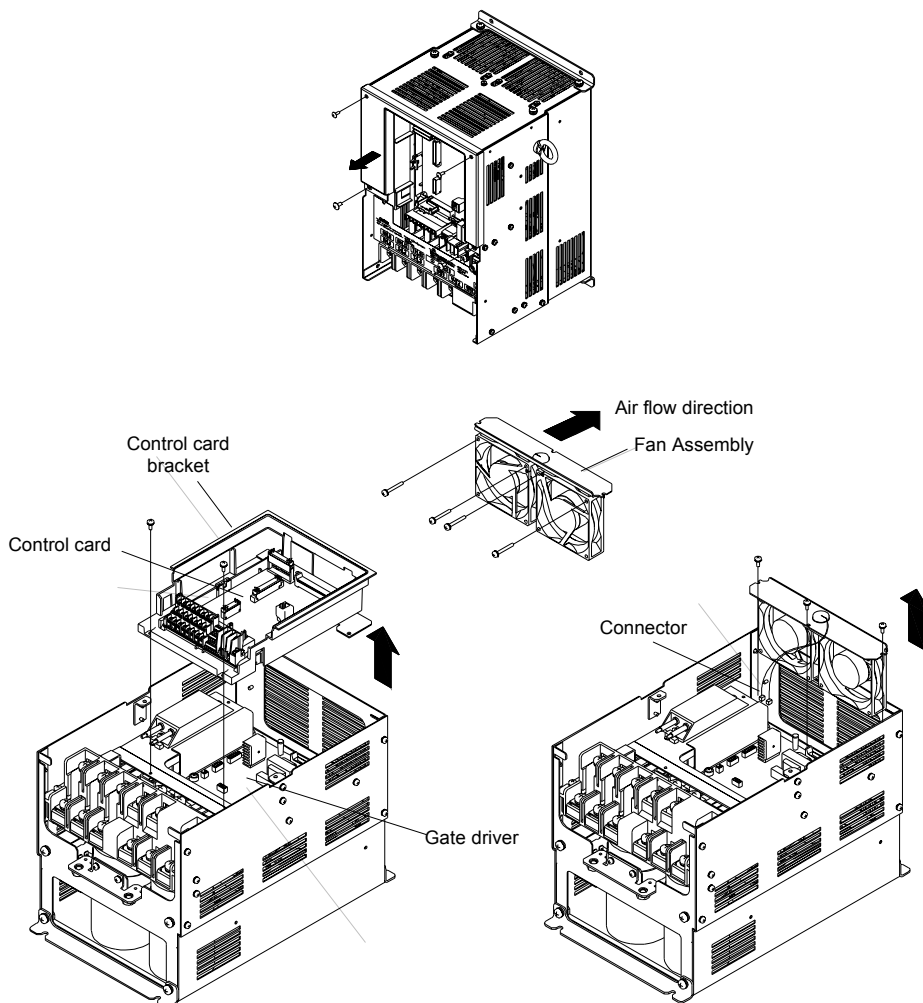

Fig 8.2 Cooling Fan Replacement (Inverters of 22 kW or More)

◆ Removing and Mounting the Terminal Card

The Terminal Card can be removed and mounted without disconnecting the control wiring.

■ Removing the Terminal Card

1. Remove the terminal cover, Digital Operator and front cover.
2. Remove the wires connected to FE and/or NC on the terminal card.
3. Loosen the mounting screws on the left and right sides of the terminal card (“1”) until they are free. It is not necessary to remove these screws completely. They are captive and self-rising.
4. Pull the terminal card out in the direction of the block arrow “2”.

■ Mounting the Terminal Card

Reverse the removal procedure to mount the terminal card.

Confirm that the terminal card and the control PCB properly meet at connector CN8 before insertion.

The connector pins may be damaged if the terminal card is forced into place, possibly preventing correct Inverter operation.

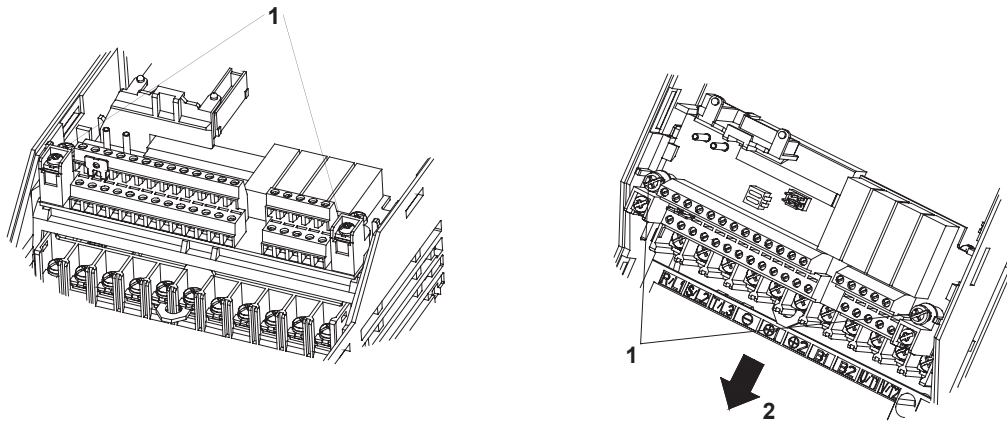

Fig 8.3 Removing the Control Circuit Terminal Card



Always confirm that the input power is removed and the Charge LED is not lit before removing or mounting the terminal card.



9

Specifications

This chapter describes the basic specifications of the Inverter and specifications for options and peripheral devices.

Standard Inverter Specifications	9-2
--	-----

Standard Inverter Specifications

The standard Inverter specifications are listed by capacity in the following tables.

◆ Specifications by Model

Specifications are given by model in the following tables.

■ 200V Class

Model Number CIMR-F7Z □	20P4	20P7	21P5	22P2	23P7	25P5	27P5	2011	2015	2018	2022	2030	2037	2045	2055	2075	2090	2110	
Max. applicable motor output (kW)*1	0.55	0.75	1.5	2.2	3.7	5.5	7.5	11	15	18.5	22	30	37	45	55	75	90	110	
Output ratings	Rated output capacity (kVA)	1.2	1.6	2.7	3.7	5.7	8.8	12	17	22	27	32	44	55	69	82	110	130	160
	Rated output current	3.2	4.1	7.0	9.6	15	23	31	45	58	71	85	115	145	180	215	283	346	415
	Max. output voltage (V)	3-phase; 200, 220, 230, or 240 VAC (Proportional to input voltage.)																	
	Max. output frequency (Hz)	Heavy Duty (low carrier, constant torque applications): 150 Hz max Normal Duty 1 or 2 (high/reduced carrier, variable torque applications): 400 Hz max.																	
Power supply characteristics	Rated voltage (V) Rated frequency (Hz)	3-phase, 200/220/230/240 VAC, 50/60 Hz																	
	Rated input current (A)	3.8	4.9	8.4	11.5	18	24	37	52	68	84	94	120	160	198	237	317	381	457
	Allowable voltage fluctuation	+ 10%, - 15%																	
	Allowable frequency fluctuation	±5%																	
Control characteristics	Measures for power supply harmonics	DC reactor	Optional										Built in						
		12-pulse rectification	Not possible										Possible*2						

* 1. The maximum applicable motor output is given for a standard 4-pole Yaskawa motor. When selecting the actual motor and Inverter, be sure that the Inverter's rated current is applicable for the motor's rated current.

* 2. A transformer with dual star-delta secondary is required on the power supply for 12-pulse rectification.

■ 400 V Class

Model Number CIMR-F7Z □		40P4	40P7	41P5	42P2	43P7	44P0	45P5	47P5	4011	4015	4018
Max. applicable motor output (kW) ^{*1}		0.55	0.75	1.5	2.2	3.7	4.0	5.5	7.5	11	15	18.5
Output ratings	Rated output capacity (kVA)	1.4	1.6	2.8	4.0	5.8	6.6	9.5	13	18	24	30
	Rated output current (A)	1.8	2.1	3.7	5.3	7.6	8.7	12.5	17	24	31	39
	Max. output voltage (V)	3-phase; 380, 400, 415, 440, 460, or 480 VAC (Proportional to input voltage.)										
	Max. output frequency (Hz)	Heavy Duty (low carrier, constant torque applications): 150 Hz max. Normal Duty 1 or 2 (high/reduced carrier, variable torque applications): 400 Hz max.										
Power supply characteristics		3-phase, 380, 400, 415, 440, 460 or 480 VAC, 50/60 Hz										
Rated input current (A)		2.2	2.5	4.4	6.4	9.0	10.4	15	20	29	37	47
Allowable voltage fluctuation		+ 10%, - 15%										
Allowable frequency fluctuation		±5%										
Control characteristics	Measures for power supply harmonics	Optional										
	DC reactor	Not possible										

Model Number CIMR-F7Z □		4022	4030	4037	4045	4055	4075	4090	4110	4132	4160	4185	4220	4300
Max. applicable motor output (kW) ^{*1}		22	30	37	45	55	75	90	110	132	160	185	220	300
Output ratings	Rated output capacity (kVA)	34	46	57	69	85	110	140	160	200	230	280	390	510
	Rated output current (A)	45	60	75	91	112	150	180	216	260	304	370	506	675
	Max. output voltage (V)	3-phase, 380, 400, 415, 440, 460, or 480 VAC (Proportional to input voltage.)												
	Max. output frequency (Hz)	Heavy Duty (low carrier, constant torque applications): 150 Hz max. Normal Duty 1 or 2 (high/reduced carrier, variable torque applications): 400 Hz max.												
Power supply characteristics		3-phase, 380, 400, 415, 440, 460, or 480 VAC, 50/60 Hz												
Rated input current (A)		50	66	83	100	120	165	198	238	286	334	407	537	743
Allowable voltage fluctuation		+ 10%, - 15%												
Allowable frequency fluctuation		±5%												
Control characteristics	Measures for power supply harmonics	Built in												
	DC reactor	Possible ^{*2}												

* 1. The maximum applicable motor output is given for a standard 4-pole Yaskawa standard motor. When selecting the actual motor and Inverter, be sure that the Inverter's rated current is higher than the motor's rated current.

* 2. A transformer with dual star-delta secondary is required on the power supply for 12-pulse-rectification.

◆ Common Specifications

The following specifications apply to both 200 V and 400 V class Inverters.

Model Number CIMR-F7Z □	Specification	
Control characteristics	Control method Sine wave PWM Closed Loop Vector control, Open Loop Vector control, V/f control, V/f with PG control	
	Torque characteristics Heavy Duty (low carrier, constant torque applications): 2 kHz carrier frequency, 150% overload for 1 minute, higher carrier frequency possible with current derating. Normal Duty 1 (high carrier, variable torque applications): maximum carrier frequency, depending on inverter capacity, 120% overload for 1 minute. Normal Duty 2 (variable torque applications): carrier frequency reduced, continuous overload capability increased	
	Speed control range 1:40 (V/f control) 1:100 (Open Loop Vector control) 1:1000 (Closed Loop Vector control)	
	Speed control accuracy ± 3% (V/f control) ± 0.03% (V/f control with PG) ± 0.2% (Open Loop Vector control) ± 0.02% (Closed Loop Vector control) (25°C ± 10°C)	
	Speed control response 5 Hz (control without PG) 30 Hz (control with PG)	
	Torque limits Provided (4 quadrant steps can be changed by constant settings.) (Vector control)	
	Torque accuracy ± 5%	
	Frequency range 0.01 to 150 Hz (Heavy Duty), 0.01 to 400 Hz (Normal Duty 1 or 2)	
	Frequency accuracy (temperature characteristics)	Digital references: ± 0.01% (-10°C to +40°C)
		Analog references: ± 0.1% (25°C ± 10°C)
	Frequency setting resolution	Digital references: 0.01 Hz
		Analog references: 0.025/50 Hz (11 bits plus sign)
	Output frequency resolution 0.01 Hz	
	Overload capacity and maximum current Heavy Duty (low carrier, constant torque applications): 150% of rated output current for 1 minute Normal Duty 1 or 2 (high/reduced carrier, variable torque applications): 120% of rated output current for 1 minute	
	Frequency setting signal 0 to +10V, -10 to +10 V, 4 to 20 mA, pulse train	
	Acceleration/Deceleration time 0.01 to 6000.0 s (4 selectable combinations of independent acceleration and deceleration time settings)	
	Braking torque Approximately 20% (Approximately 125% with Braking Resistor option, braking transistor built into Inverters of 18.5 kW or less)	
	Main control functions Restarting after momentary power loss, speed search, overtorque/undertorque detection, torque limits, 17-speed control (maximum), 4 acceleration and deceleration times, S-curve acceleration/deceleration, 3-wire control, auto-tuning (rotational or stationary), dwell function, cooling fan ON/OFF control, slip compensation, torque compensation, auto-restart after fault, jump frequencies, upper and lower limits for frequency references, DC braking for starting and stopping, high-slip braking, advanced PID control, energy-saving control, MEMOBUS communications (RS-485/422, 19.2 kbps maximum), 2 motor parameter sets, fault reset and parameter copy function.	
	Protective functions	Motor protection Protection by electronic thermal overload relay.
Instantaneous overcurrent protection Stops at approx. 200% of rated output current.		
Fuse blown protection Stops for fuse blown.		
Overload protection Heavy Duty (low carrier, constant torque applications): 150% of rated output current for 1 minute Normal Duty 1 (high carrier, variable torque applications): 120% of rated output current for 1 minute Normal Duty 2 (high carrier, variable torque applications): 120% of rated output current for 1 minute, increased continuous output current.		
Overvoltage protection 200 Class Inverter: Stops when main-circuit DC voltage is above 410 V. 400 Class Inverter: Stops when main-circuit DC voltage is above 820 V.		
Undervoltage protection 200 Class Inverter: Stops when main-circuit DC voltage is below 190 V. 400 Class Inverter: Stops when main-circuit DC voltage is below 380 V.		
Momentary power loss ride through By selecting the momentary power loss method, operation can be continued if power is restored within 2 s.		
Cooling fin overheating Protection by thermistor.		
Stall prevention Stall prevention during acceleration, deceleration and running independently.		
Grounding protection Protection by electronic circuits.		
Charge indicator Glowes when the main circuit DC voltage is approx. 10 VDC or more.		
Protective structure Enclosed wall-mounted type (NEMA 1): 18.5 kW or less (same for 200 V and 400 V class Inverters) Open chassis type (IP00): 22 kW or more (same for 200 V and 400 V class Inverters)		

Model Number CIMR-F7Z □		Specification
Environment	Ambient operating temperature	-10°C to 40°C (Enclosed wall-mounted type) -10°C to 45°C (Open chassis type)
	Ambient operating humidity	95% max. (with no condensation)
	Storage temperature	- 20°C to + 60°C (short-term temperature during transportation)
	Application site	Indoor (no corrosive gas, dust, etc.)
	Altitude	1000 m max.
	Vibration	10 to 20 Hz, 9.8 m/s ² max.; 20 to 50 Hz, 2 m/s ² max





10

Appendix

This chapter provides precautions for the Inverter, motor, and peripheral devices and also provides lists of constants.

Inverter Application Precautions	10-2
Motor Application Precautions	10-5
User Constants	10-7

Inverter Application Precautions

◆ Selection

Observe the following precautions when selecting an Inverter.

■ Installing Reactors

A large peak current will flow in the power input circuit when the Inverter is connected to a large-capacity power transformer (600 kVA or higher) or when switching a compensating capacitor. Excessive peak current can destroy the rectifier section. To prevent this, install a DC or AC reactor to improve the power supply power factor.

DC reactors are built into Inverters of 22kW and more.

If a thyristor converter, such as a DC drive, is connected in the same power supply system, connect a DC or AC reactor regardless of the power supply conditions shown in the following diagram.

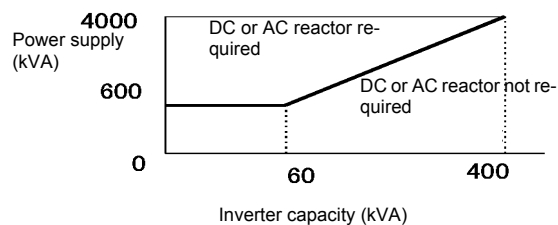

■ Inverter Capacity in Multiple Motors Applications

When connecting multiple motors in parallel to an Inverter, select the Inverter capacity so that the rated output current of the Inverter is minimum 1.1 times the sum of all the motor rated currents.

■ Initial Torque

The startup and acceleration characteristics of the motor are restricted by the overload current ratings of the Inverter that is driving the motor. The torque characteristic generally is different from those when starting a motor on the power supply directly. If a large initial torque is required, select an Inverter one size bigger or increase the capacity of both, the motor and the Inverter.

◆ Installation

Observe the following precautions when installing an Inverter.

■ Installation in Enclosures

Install the Inverter in a clean location where it is not subjected to oil mist, dust, and other contaminants, or install the Inverter in a completely enclosed panel. Provide cooling measures and sufficient panel space so that the temperature surrounding the Inverter does not exceed the allowable temperature. Do not install the Inverter on wood or other combustible materials.

■ Installation Direction

Mount the Inverter vertically to a wall or other vertical surface.

◆ Settings

Observe the following precautions when making settings for an Inverter.

■ Upper Limits

The maximum output frequency can be set up to 400Hz. Setting the output frequency too high can damage the machine. So pay attention to the mechanical system and observe required limits for the output frequency.

■ DC Injection Braking

If the DC Injection Braking Current or the Braking Time are set too high the motor can overheat what can damage the motor

■ Acceleration/Deceleration Times

The motor's acceleration and deceleration times are determined by the torque generated by the motor, the load torque, and the load's inertial moment ($GD^2/4$). If the stall prevention functions are activated during acceleration or deceleration, it might be necessary to increase the acceleration or deceleration time.

To reduce the acceleration or deceleration times, increase the capacity of the motor and Inverter.

◆ Handling

Observe the following precautions when wiring or performing maintenance for an Inverter.

■ Wiring Check

The Inverter will be internally damaged if the power supply voltage is applied to output terminal U, V, or W. Check wiring for any mistakes before supplying power. Check all wiring and control sequences carefully.

■ Magnetic Contactor Installation

If a magnetic contactor is installed in the power supply line do not exceed one start per hour. Switching more often can damage the inrush current prevention circuit.

■ Maintenance and Inspections

After turning OFF the main circuit power supply it can take several minutes before the DC bus is discharged completely. The CHARGE LED, indicating if the DC bus is charged, glows above a voltage of 10VD.

Motor Application Precautions

◆ Using the Inverter for an Existing Standard Motor

Observe the following precautions when using an Inverter for an existing standard motor.

■ Low Speed Ranges

If a standard cooled motor is used at low speed the cooling effects are diminished. If the motor is used in constant torque applications in low speed area the motor may overheat. If full torque is required at low speed continuously an externally cooled motor must be used.

■ Installation Withstand Voltage

If the inverter is used with an input voltage of 440 V or higher and long motor cables, voltage spikes at the motor terminals may occur which can damage the motor windings. Please ensure that the motor insulation class is sufficient.

■ High-speed Operation

When using the motor at a speed higher than the motor rated frequency (usually 50 Hz), problems may arise in dynamic balance and bearing durability.

■ Acoustic Noise

The noise generated in the motor depends on the carrier frequency. The higher the setting the less the generated noise is.

◆ Using the Inverter for Special Motors

Observe the following precautions when using a special motor.

■ Pole-changing Motor

The rated input current of pole-changing motors differs from that of standard motors. Select an appropriate Inverter according to the maximum current of the motor.

■ Submersible Motor

The rated input current of submersible motors is higher than that of standard motors. Therefore, always select an appropriate Inverter according to the maximum current of the motor.

■ Explosion-proof Motor

When an explosion-proof motor is used, it must be subjected to an explosion-proof test in conjunction with the Inverter. This is also applicable when an existing explosion-proof motor is to be operated with the Inverter. Since the Inverter itself is, however, not explosion-proof, always install it in a safe place.

■ Gear motor

The speed range for continuous operation differs according to the lubrication method and motor manufacturer. In particular, continuous operation of an oil-lubricated motor in the low speed range may result in damaging. If the motor is to be operated at a speed higher than 50 Hz, consult the manufacturer.

■ Synchronous Motor

A synchronous motor is not suitable for Inverter control.

■ Single-phase Motor

Do not use an Inverter for a single-phase capacitor motor. Any capacitors directly connected to the inverter output may damage the Inverter.

◆ Power Transmission Mechanism (Speed Reducers, Belts and Chains)

If an oil-lubricated gearbox or speed reducer is used in the power transmission mechanism, oil lubrication will be affected when the motor operates only in the low speed range. The power transmission mechanism will make noise and experience problems with service life and durability if the motor is operated at low speeds continuously.

User Constants

Factory settings are given in the following table. These are factory settings for a 200 V Class Inverter with 0.4 kW (open loop vector control).

No.	Name	Factory Setting	Setting
A1-00	Language selection for Digital Operator display	0	
A1-01	Parameter access level	2	
A1-02	Control method selection	2	
A1-03	Initialize	0	
A1-04	Password	0	
A1-05	Password setting	0	
A2-01 to A2-32	User specified parameters	–	
b1-01	Reference source selection	1	
b1-02	RUN command source selection	1	
b1-03	Stopping method selection	0	
b1-04	Prohibition of reverse operation	0	
b1-05	Operation selection for setting frequencies equal or lower than E1-09	0	
b1-06	Control input scan	1	
b1-07	Operation selection after switching to remote mode	0	
b1-08	Run command selection in programming modes	0	
b2-01	Zero speed level (DC injection braking starting frequency)	0.5 Hz	
b2-02	DC injection braking current	50%	
b2-03	DC injection braking time at start	0.00 s	
b2-04	DC injection braking time at stop	0.50 s	
b2-08	Magnetic flux compensation volume	0%	
b3-01	Speed search selection (current detection or speed calculation)	*1	
b3-02	Speed search operating current (current detection)	*1	
b3-03	Speed search deceleration time (current detection)	2.0 s	
b3-05	Speed search wait time (current detection or speed calculation)	0.2 s	
b3-10	Speed Search Compensation Gain (speed calculation only)	1.10	
b3-14	Speed Search Rotating Selection Direction	1	
b4-01	Timer function ON-delay time	0.0 s	
b4-02	Timer function OFF-delay time	0.0 s	
b5-01	PID control mode selection	0	
b5-02	Proportional gain (P)	1.00	
b5-03	Integral (I) time	1.0 s	
b5-04	Integral (I) limit	100.0%	
b5-05	Differential (D) time	0.00 s	
b5-06	PID limit	100.0%	
b5-07	PID offset adjustment	0.0%	
b5-08	PID delay time constant	0.00 s	
b5-09	PID output characteristics selection	0	
b5-10	PID output gain	1.0	
b5-11	PID reverse output selection	0	
b5-12	Selection of PID feedback signal loss detection	0	
b5-13	PID feedback loss detection level	0%	

No.	Name	Factory Setting	Setting
b5-14	PID feedback loss detection time	1.0 s	
b5-15	PID Sleep function operation level	0.0 Hz	
b5-16	PID Sleep operation delay time	0.0 s	
b5-17	Accel/decel time for PID reference	0.0 s	
b5-18	PID Setpoint Selection	0	
b5-19	PID Setpoint	0	
b5-28	PID Square Root Feedback Sel	0	
b5-29	Square root Feedback Gain	1.00	
b5-31	PID monitor feedback selection	0	
b5-32	PID monitor feedback gain	100.0%	
b5-33	PID monitor feedback bias	0.0%	
b6-01	Dwell frequency at start	0.0 Hz	
b6-02	Dwell time at start	0.0 s	
b6-03	Dwell frequency at stop	0.0 Hz	
b6-04	Dwell time at stop	0.0 s	
b7-01	Droop Control Gain	0.0%	
b7-02	Droop Control Delay Time	0.05 s	
b8-01	Energy-saving mode selection	0	
b8-02	Energy-saving gain	*1	
b8-03	Energy-saving filter time constant	*1	
b8-04	Energy-saving coefficient	*1	
b8-05	Power detection filter time constant	20 ms	
b8-06	Search operation voltage limiter	0%	
b9-01	Zero Servo Gain	5	
b9-02	Zero Servo completion bandwidth	10	
C1-01	Acceleration time 1	10.0 s	
C1-02	Deceleration time 1	10.0 s	
C1-03	Acceleration time 2		
C1-04	Deceleration time 2		
C1-05	Acceleration time 3		
C1-06	Deceleration time 3		
C1-07	Acceleration time 4		
C1-08	Deceleration time 4		
C1-09	Emergency stop time		
C1-10	Accel/decel time setting unit		1
C1-11	Accel/decel time switching frequency	0.0 Hz	
C2-01	S-curve characteristic time at acceleration start	0.20 s	
C2-02	S-curve characteristic time at acceleration end	0.20 s	
C2-03	S-curve characteristic time at deceleration start	0.20 s	
C2-04	S-curve characteristic time at deceleration end	0.00 s	
C3-01	Slip compensation gain	*1	
C3-02	Slip compensation delay time	*1	
C3-03	Slip compensation limit	200%	
C3-04	Slip compensation selection during regeneration	0	
C3-05	Output voltage limit operation selection	0	

No.	Name	Factory Setting	Setting
C4-01	Torque compensation gain	1.00	
C4-02	Torque compensation delay time constant	*1	
C4-03	Starting torque compensation (FWD)	0.0%	
C4-04	Starting torque compensation (REV)	0.0%	
C4-05	Starting torque compensation time constant	10 ms	
C5-01	ASR proportional (P) gain 1	*1	
C5-02	ASR integral (I) time 1	*1	
C5-03	ASR proportional (P) gain 2	*1	
C5-04	ASR integral (I) time 2	*1	
C5-05	ASR limit	5.0%	
C5-06	ASR delay time	0.004 ms	
C5-07	ASR switching frequency	0.0 Hz	
C5-08	ASR integral (I) limit	400%	
C6-01	Heavy/Normal Duty selection	0	
C6-02	Carrier frequency selection	1	
C6-03	Carrier frequency upper limit	2.0 kHz	
C6-04	Carrier frequency lower limit	2.0 kHz	
C6-05	Carrier frequency proportional gain	00	
d1-01	Frequency reference 1	0.00 Hz	
d1-02	Frequency reference 2	0.00 Hz	
d1-03	Frequency reference 3	0.00 Hz	
d1-04	Frequency reference 4	0.00 Hz	
d1-05	Frequency reference 5	0.00 Hz	
d1-06	Frequency reference 6	0.00 Hz	
d1-07	Frequency reference 7	0.00 Hz	
d1-08	Frequency reference 8	0.00 Hz	
d1-09	Frequency reference 9	0.00 Hz	
d1-10	Frequency reference 10	0.00 Hz	
d1-11	Frequency reference 11	0.00 Hz	
d1-12	Frequency reference 12	0.00 Hz	
d1-13	Frequency reference 13	0.00 Hz	
d1-14	Frequency reference 14	0.00 Hz	
d1-15	Frequency reference 15	0.00 Hz	
d1-16	Frequency reference 16	0.00 Hz	
d1-17	Jog frequency reference	6.00 Hz	
d2-01	Frequency reference upper limit	100.0%	
d2-02	Frequency reference lower limit	0.0%	
d2-03	Master speed reference lower limit	0.0%	
d3-01	Jump frequency 1	0.0 Hz	
d3-02	Jump frequency 2	0.0 Hz	
d3-03	Jump frequency 3	0.0 Hz	
d3-04	Jump frequency width	1.0 Hz	
d4-01	Frequency reference hold function selection	0	
d4-02	+ - Speed limits	10%	
d5-01	Torque control selection	0	

No.	Name	Factory Setting	Setting
d5-02	Torque reference delay time	0 ms	
d5-03	Speed limit selection	1	
d5-04	Speed limit	0%	
d5-05	Speed limit bias	10%	
d5-06	Speed/torque control switching timer	0 ms	
d6-01	Field weakening level	80%	
d6-02	Field weakening frequency limit	0.0 Hz	
d6-03	Field forcing function selection	0	
d6-06	Field forcing function Limit	400%	
E1-01	Input voltage setting	*1	
E1-03	V/f pattern selection	F	
E1-04	Max. output frequency (FMAX)	50.0 Hz	
E1-05	Max. output voltage (VMAX)	*1	
E1-06	Base frequency (FA)	50.0 Hz	
E1-07	Mid. output frequency (FB)	*1	
E1-08	Mid. output frequency voltage (VB)	*1	
E1-09	Min. output frequency (FMIN)	*1	
E1-10	Min. output frequency voltage (VMIN)	*1	
E1-11	Mid. output frequency 2	0.0 Hz	
E1-12	Mid. output frequency voltage 2	0.0 V	
E1-13	Base voltage (VBASE)	0.0 V	
E2-01	Motor rated current	*1	
E2-02	Motor rated slip	*1	
E2-03	Motor no-load current	*1	
E2-04	Number of motor poles	4 poles	
E2-05	Motor line-to-line resistance	*1	
E2-06	Motor leak inductance	*1	
E2-07	Motor iron saturation coefficient 1	0.50	
E2-08	Motor iron saturation coefficient 2	0.75	
E2-09	Monitor mechanical losses	0.0%	
E2-10	Motor iron loss for torque compensation	*1	
E2-11	Motor rated output power	*1	
E3-01	Motor 2 control method selection	0	
E3-02	Motor 2 max. output frequency (FMAX)	50.0 Hz	
E3-03	Motor 2 max. output voltage (VMAX)	*1	
E3-04	Motor 2 max. output voltage frequency (FA)	50.0 Hz	
E3-05	Motor 2 mid. output frequency 1 (FB)	*1	
E3-06	Motor 2 mid. output frequency voltage 1 (VB)	*1	
E3-07	Motor 2 min. output frequency (FMIN)	*1	
E3-08	Motor 2 min. output frequency voltage (VMIN)	*1	
E4-01	Motor 2 rated current	*1	
E4-02	Motor 2 rated slip	*1	
E4-03	Motor 2 no-load current	*1	
E4-04	Motor 2 number of poles (number of poles)	4 poles	
E4-05	Motor 2 line-to-line resistance	*1	

No.	Name	Factory Setting	Setting
E4-06	Motor 2 leak inductance	*1	
E4-07	Motor 2 rated capacity	*1	
F1-01	PG constant	1024	
F1-02	Operation selection at PG open circuit (PGO)	1	
F1-03	Operation selection at overspeed (OS)	1	
F1-04	Operation selection at deviation	3	
F1-05	PG rotation	0	
F1-06	PG division rate (PG pulse monitor)	1	
F1-07	Integral value during accel/decel enable/disable	0	
F1-08	Overspeed detection level	115%	
F1-09	Overspeed detection delay time	1.0 s	
F1-10	Excessive speed deviation detection level	10%	
F1-11	Excessive speed deviation detection delay time	0.5 s	
F1-12	Number of PG gear teeth 1	0	
F1-13	Number of PG gear teeth 2	0	
F1-14	PG open-circuit detection delay time	2.0 s	
F2-01	Bi-polar or uni-polar input selection	0	
F3-01	Digital input option	0	
F6-01	Operation selection after communications error	1	
F6-02	Input level of external error from Communications Option Card	0	
F6-03	Stopping method for external error from Communications Option Card	1	
F6-04	Trace sampling from Communications Option Card	0	
F6-05	Current monitor unit selection	1	
F6-06	Torque reference/torque limit selection from communications option card	1	
H1-01	Terminal S3 function selection	24	
H1-02	Terminal S4 function selection	14	
H1-03	Terminal S5 function selection	3 (0) ^{*2}	
H1-04	Terminal S6 function selection	4 (3) ^{*2}	
H1-05	Terminal S7 function selection	6 (4) ^{*2}	
H2-01	Terminal M1-M2 function selection	0	
H2-02	Terminal M3-M4 function selection	1	
H2-03	Terminal M5-M6 function selection	2	
H3-01	Multi-function analog input terminal A1 signal level selection	0	
H3-02	Gain (terminal A1)	100.0%	
H3-03	Bias (terminal A1)	0.0%	
H3-08	Multi-function analog input terminal A2 signal level selection	2	
H3-09	Multi-function analog input terminal A2 function selection	0	
H3-10	Gain (terminal A2)	100.0%	
H3-11	Bias (terminal A2)	0.0%	
H3-12	Analog input filter time constant	0.00 s	
H3-13	Terminal A1/A2 switching	0	
H4-01	Monitor selection (terminal FM)	2	
H4-02	Gain (terminal FM)	100%	
H4-03	Bias (terminal FM)	0.0%	

No.	Name	Factory Setting	Setting
H4-04	Monitor selection (terminal AM)	3	
H4-05	Gain (terminal AM)	50.0%	
H4-06	Bias (terminal AM)	0.0%	
H4-07	Analog output 1 signal level selection	0	
H4-08	Analog output 2 signal level selection	0	
H5-01	Station address	1F	
H5-02	Communications speed selection	3	
H5-03	Communications parity selection	0	
H5-04	Stopping method after communications error	3	
H5-05	Communications error detection selection	1	
H5-06	Send wait time	5 ms	
H5-07	RTS control ON/OFF	1	
H6-01	Pulse train input function selection	0	
H6-02	Pulse train input scaling	1440 Hz	
H6-03	Pulse train input gain	100.0%	
H6-04	Pulse train input bias	0.0%	
H6-05	Pulse train input filter time	0.10 s	
H6-06	Pulse train monitor selection	2	
H6-07	Pulse train monitor scaling	1440 Hz	
L1-01	Motor protection selection	1	
L1-02	Motor protection time constant	1.0 min	
L1-03	Alarm operation selection during motor overheating	3	
L1-04	Motor overheating operation selection	1	
L1-05	Motor temperature input filter time constant	0.20 s	
L2-01	Momentary power loss detection	0	
L2-02	Momentary power loss ride through time	*1	
L2-03	Min. baseblock time	*1	
L2-04	Voltage recovery time	*1	
L2-05	Undervoltage detection level	*1	
L2-06	KEB deceleration time	0.0 s	
L2-07	Momentary recovery time	*1	
L2-08	Frequency reduction gain at KEB start	100%	
L3-01	Stall prevention selection during accel	1	
L3-02	Stall prevention level during accel	150%	
L3-03	Stall prevention limit during accel	50%	
L3-04	Stall prevention selection during decel	1	
L3-05	Stall prevention selection during running	1	
L3-06	Stall prevention level during running	150%	
L4-01	Speed agreement detection level	0.0 Hz	
L4-02	Speed agreement detection width	2.0 Hz	
L4-03	Speed agreement detection level (+/-)	0.0 Hz	
L4-04	Speed agreement detection width (+/-)	2.0 Hz	
L4-05	Operation when frequency reference is missing	0	
L4-06	Frequency reference value at frequency reference loss	80%	
L5-01	Number of auto restart attempts	0	

No.	Name	Factory Setting	Setting
L5-02	Auto restart operation selection	0	
L6-01	Torque detection selection 1	0	
L6-02	Torque detection level 1	150%	
L6-03	Torque detection time 1	0.1 s	
L6-04	Torque detection selection 2	0	
L6-05	Torque detection level 2	150%	
L6-06	Torque detection time 2	0.1 s	
L7-01	Forward drive torque limit	200%	
L7-02	Reverse drive torque limit	200%	
L7-03	Forward regenerative torque limit	200%	
L7-04	Reverse regenerative torque limit	200%	
L7-06	Torque limit time constant	200 ms	
L7-07	Torque Limit Operation during accel/decel	0	
L8-01	Protect selection for internal DB resistor (Type ERF)	0	
L8-02	Overheat pre-alarm level	95 °C*1	
L8-03	Operation selection after overheat pre-alarm	3	
L8-05	Input open-phase protection selection	1	
L8-07	Output open-phase protection selection	0	
L8-09	Ground protection selection	1	
L8-10	Cooling fan control selection	0	
L8-11	Cooling fan control delay time	60 s	
L8-12	Ambient temperature	45 °C	
L8-15	OL2 characteristics selection at low speeds	1	
L8-18	Soft CLA selection	1	
N1-01	Hunting-prevention function selection	1	
N1-02	Hunting-prevention gain	1.00	
N2-01	Speed feedback detection control (AFR) gain	1.00	
N2-02	Speed feedback detection control (AFR) time constant	50 ms	
N2-03	Speed feedback detection control (AFR) time constant 2	750 ms	
N3-01	High-slip braking deceleration frequency width	5%	
N3-02	High-slip braking current limit	150%	
N3-03	High-slip braking stop dwell time	1.0 s	
N3-04	High-slip braking OL time	40 s	
o1-01	Monitor selection	6	
o1-02	Monitor selection after power up	1	
o1-03	Frequency units of reference setting and monitor	0	
o1-04	Setting unit for frequency parameters related to V/f characteristics	0	
o1-05	LCD Display contrast adjustment	3	
o2-01	LOCAL/REMOTE key enable/disable	1	
o2-02	STOP key during control circuit terminal operation	1	
o2-03	User parameter initial value	0	
o2-04	kVA selection	0	
o2-05	Frequency reference setting method selection	0	
o2-06	Operation selection when digital operator is disconnected	0	
o2-07	Cumulative operation time setting	0 hr	

No.	Name	Factory Setting	Setting
o2-08	Cumulative operation time selection	0	
o2-09	Initialize Mode	2	
o2-10	Fan operation time setting	0 hr	
o2-12	Fault trace initialize	0	
o2-13	kWh monitor initialize	0	
o3-01	Copy function selection	0	
o3-02	Read permission selection	0	
T1-00	Motor 1/2 selection	1	
T1-01	Autotuning mode selection	0	
T1-02	Motor output power	*1	
T1-03	Motor rated voltage	*1	
T1-04	Motor rated current	*1	
T1-05	Motor base frequency	50.0 Hz	
T1-06	Number of motor poles	4 poles	
T1-07	Motor base speed	1450 r/min	
T1-08	Number of PG pulses	1024	

* 1. The factory setting depends on the inverter model and the control method.

* 2. The values in parentheses indicate initial values when initialized in 3-wire sequence.