

Rotary Servomotors

SGMAV



Model Designations

● Without Gears

SGMAV - 01 A D A 2 1

Σ-V Series
Servomotor
SGMAV

1st+2nd
digits

3rd
digit

4th
digit

5th
digit

6th
digit

7th
digit

1st+2nd digits Rated Output

Code	Specifications
A5	50 W
01	100 W
C2	150 W
02	200 W
04	400 W
06	550 W
08	750 W
10	1.0 kW

5th digit Design Revision Order

Code	Specifications
A	Standard

7th digit Options

Code	Specifications
1	Without options
C	With holding brake (24 VDC)
E	With oil seal and holding brake (24 VDC)
S	With oil seal

6th digit Shaft End

Code	Specifications
2	Straight without key (standard)
6	Straight with key and tap (optional)
B	With two flat seats (optional)

3rd digit Power Supply Voltage

Code	Specifications
A	200 VAC

4th digit Serial Encoder

Code	Specifications
3	20-bit absolute (standard)
D	20-bit incremental (standard)

Features

- Super high power rate (Extremely low inertia)
- Instantaneous peak torque (300% of rated torque)
- Mounted high-resolution serial encoder: 20 bits
- Maximum speed: 6,000 min⁻¹
- Wide selection: 50 W to 1.0 kW capacity, holding brake options

Application Examples

- Semiconductor equipment
- Chip mounters
- PCB drilling stations
- Robots
- Material handling machines
- Food processing equipment



Model	SGMAV-10ADA61	SGMAV-06ADA61	SGMAV-01ADA61
Rated Output	1.0 kW	550 W	100 W
Flange Face	80 mm x 80 mm	60 mm x 60 mm	40 mm x 40 mm

Ratings and Specifications

Time Rating: Continuous

Vibration Class: V15

Insulation Resistance: 500 VDC, 10 MΩ min.

Ambient Temperature: 0 to 40°C

Excitation: Permanent magnet

Mounting: Flange-mounted

Thermal Class: B

Withstand Voltage: 1500 VAC for one minute

Enclosure: Totally enclosed, self-cooled, IP65
(except for shaft opening)

Ambient Humidity: 20% to 80% (no condensation)

Drive Method: Direct drive

Rotation Direction: Counterclockwise (CCW) with forward run reference when viewed from the load side

Voltage		230 V							
Servomotor Model: SGMAV-		A5A	01A	C2A	02A	04A	06A	08A	10A
Rated Output ^{*1}	W	50	100	150	200	400	550	750	1000
Rated Torque ^{*1, *2}	Nm	0.159	0.318	0.477	0.637	1.27	1.75	2.39	3.18
Instantaneous Peak Torque ^{*1}	Nm	0.477	0.955	1.43	1.91	3.82	5.25	7.16	9.55
Rated Current ^{*1}	Arms	0.66	0.91	1.3	1.5	2.6	3.8	5.3	7.4
Instantaneous Max. Current ^{*1}	Arms	2.1	2.8	4.2	5.3	8.5	12.2	16.6	23.9
Rated Speed ^{*1}	min ⁻¹	3000							
Max. Speed ^{*1}	min ⁻¹	6000							
Torque Constant	Nm/Arms	0.265	0.375	0.381	0.450	0.539	0.496	0.487	0.467
Rotor Moment of Inertia	×10 ⁻⁴ kgm ²	0.0242 (0.0389)	0.0380 (0.0527)	0.0531 (0.0678)	0.116 (0.180)	0.190 (0.254)	0.326 (0.403)	0.769 (0.940)	1.20 (1.41)
Rated Power Rate ^{*1}	kW/s	10.4	26.6	42.8	35.0	84.9	93.9	74.1	84.3
Rated Angular Acceleration ^{*1}	rad/s ²	65800	83800	89900	54900	67000	53700	31000	26500
Applicable SERVOPACK	SGDV-	R70	R90	1R6A		2R8	5R5A	5R5A	120A

*1: These items and torque-speed characteristics quoted in combination with an SGDV SERVOPACK are at an armature winding temperature of 100°C. Other values quoted are at 20°C.

*2: Rated torques are continuous allowable torque values at 40°C with an aluminum heat sink of the following dimensions attached.
 SGMAV-A5A, -01A: 200 mm × 200 mm × 6 mm
 SGMAV-C2A, -02A, -04A, -06A, -08A: 250 mm × 250 mm × 6 mm
 SGMAV-10A: 300 mm × 300 mm × 12 mm

Note: The values in parentheses are for servomotors with holding brakes.

● Torque-Speed Characteristics [A]: Continuous Duty Zone [B]: Intermittent Duty Zone

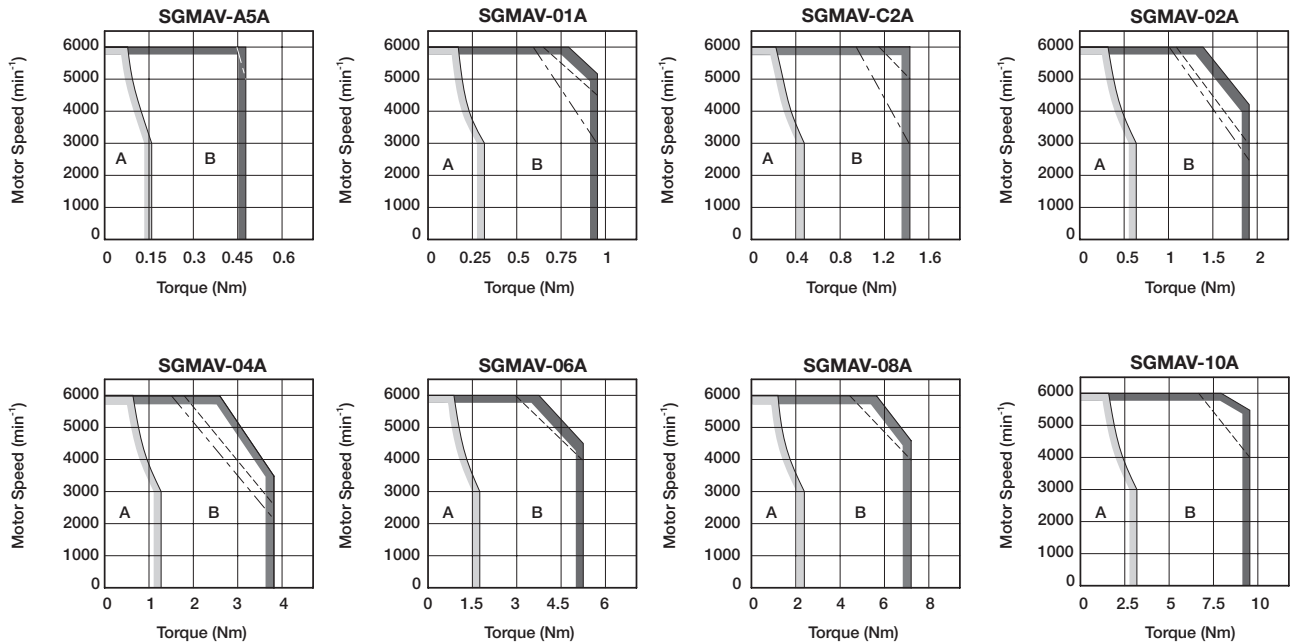

Notes: 1 The characteristics of the intermittent duty zone differ depending on the supply voltages. The solid, dotted, and dashed-dotted lines of the intermittent duty zone indicate the characteristics when a servomotor runs with the following combinations:

- The solid line: With a three-phase 200 V or a single-phase 230 V SERVOPACK
- The dotted line: With a single-phase 200 V SERVOPACK
- The dashed-dotted line: With a single-phase 100 V SERVOPACK

An SGMAV-A5A servomotor combined with a single-phase 200 V SERVOPACK has the same characteristics as one combined with a three-phase 200 V SERVOPACK.

2 When the effective torque is within the rated torque, the servomotor can be used within the intermittent duty zone.

3 When the main circuit cable length exceeds 20 m, note that the intermittent duty zone of the *Torque-Speed Characteristics* will shrink as the line-to-line voltage drops.

Ratings and Specifications

● Derating Rate for Servomotor Fitted with an Oil Seal

When a motor is fitted with an oil seal, use the following derating rate because of the higher friction torque.

Servomotor Model SGMVA-	A5A	01A	C2A	02A	04A	06A	08A	10A
Derating Rate %	80	90			95			

● Holding Brake Electrical Specifications

Holding Brake Rated Voltage	Servomotor Model	Servomotor Rated Output W	Holding Brake Specifications					
			Capacity W	Holding Torque Nm	Coil Resistance Ω (at 20°C)	Rated Current A (at 20°C)	Brake Release Time ms	Brake Operation Time ms
24 VDC $\pm 10\%$	SGMAV-A5A	50	5.5	0.159	103	0.23	60	100
	SGMAV-01A	100		0.318				
	SGMAV-C2A	150	5.1	0.477	114	0.21	60	100
	SGMAV-02A	200	6	0.637	97.4	0.25	60	100
	SGMAV-04A	400		1.27				
	SGMAV-06A	550	8	1.75	74.3	0.32	80	100
	SGMAV-08A	750	6.5	2.39	87.7	0.27	80	100
	SGMAV-10A	1000	7	3.18	82.8	0.29	80	100

- Notes: 1 The holding brake is only used to hold the load and cannot be used to stop the servomotor.
- 2 The holding brake open time and holding brake operation time vary depending on which discharge circuit is used. Make sure holding brake open time and holding brake operation time are correct for your servomotor.
- 3 A 24-VDC power supply is provided by customers.

● Overload Characteristics

The overload detection level is set under hot start conditions at a servomotor ambient temperature of 40°C.

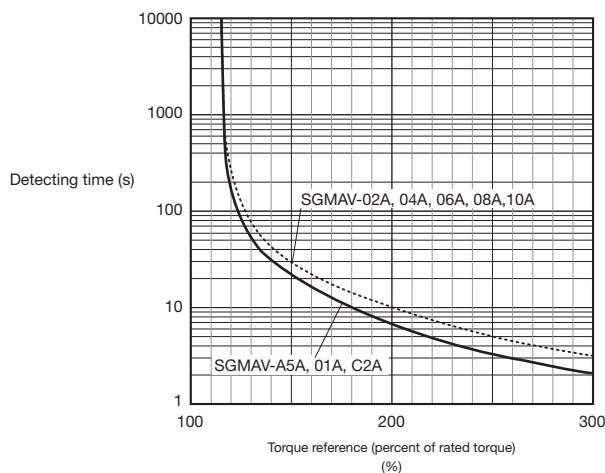

Note: Overload characteristics shown above do not guarantee continuous duty of 100% or more output. Use a servomotor with effective torque within the continuous duty zone of Torque-Speed Characteristics.

Ratings and Specifications

● Allowable Load Moment of Inertia at the Motor Shaft

The rotor moment of inertia ratio is the value for a servomotor without a gear and a brake.

Servomotor Model		Servomotor Rated Output	Allowable Load Moment of Inertia (Rotor Moment of Inertia Ratio)
SGMAV-	A5A, 01A, C2A, 02A	50 to 200 W	30 times
	04A, 06A, 08A	400 to 750 W	20 times
	10A	1000 W	10 times

● Load Moment of Inertia

The larger the load moment of inertia, the worse the movement response.

The allowable load moment of inertia (J_L) depends on the motor capacity, as shown above. This value is provided strictly as a guideline and results may vary depending on servomotor drive conditions.

Use the AC servo drive capacity selection program SigmaJunmaSize+ to check the operation conditions. The program can be downloaded for free from our web site (<http://www.yaskawa.eu.com>).

An overvoltage alarm (A.400) is likely to occur during deceleration if the load moment of inertia exceeds the allowable load moment of inertia. SERVOPACKs with a built-in regenerative resistor may generate a regenerative overload alarm (A.320). Take one of the following steps if this occurs.

- Reduce the torque limit.
- Reduce the deceleration rate.
- Reduce the maximum speed.
- Install an external regenerative resistor if the alarm cannot be cleared using the steps above. Refer to *Regenerative Resistors* on page 364.

Regenerative resistors are not built into SERVOPACKs for 400 W motors or less.

External regenerative resistors are required when this condition is exceeded or if the allowable loss capacity (W) of the built-in regenerative resistor is exceeded due to regenerative drive conditions when a regenerative resistor is already built in.

● Allowable Radial and Thrust Loads

Design the mechanical system so thrust and radial loads applied to the servomotor shaft end during operation fall within the ranges shown in the table.

Servomotor Model		Allowable Radial Load (Fr) N	Allowable Thrust Load (Fs) N	LF mm	Reference Diagram
SGMAV-	A5A	78	54	20	
	01A				
	C2A				
	02A	245	74	25	
	04A				
	06A				
	08A				
	10A	392	147	35	

External Dimensions Units: mm

(1) 50 to 150 W

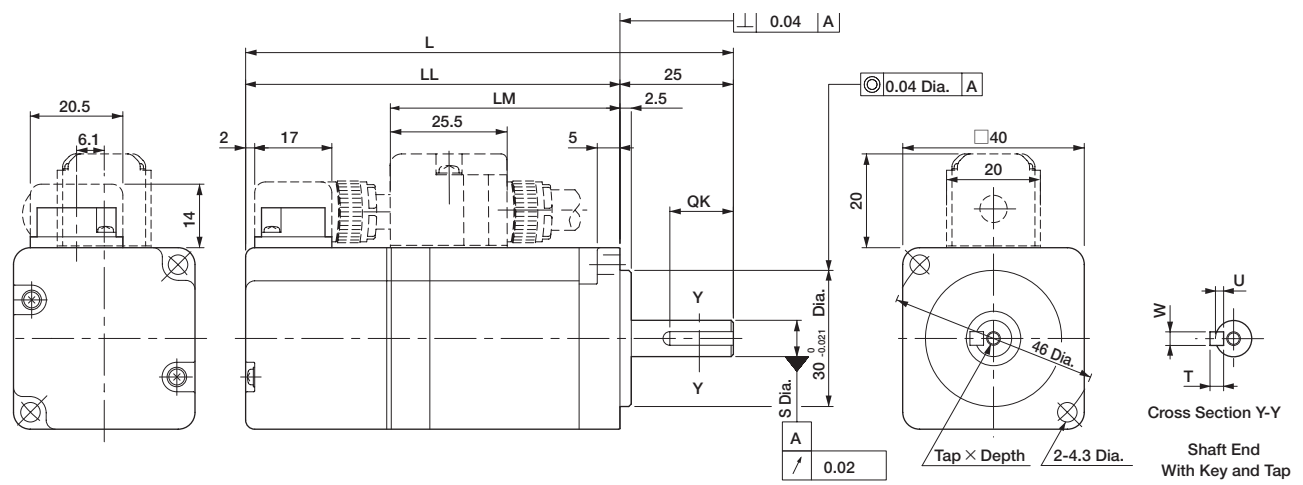

Model SGMAV-	L	LL	LM	S	Tap × Depth	Key Dimensions				Approx. Mass kg
						QK	U	W	T	
A5A□A21 (A5A□A2C)	95.5 (140.5)	70.5 (115.5)	38.5	8 ⁰ _{-0.009} *	No tap	No key				0.3 (0.6)
M3 × 6L					14	1.8	3	3		
A5A□A61 (A5A□A6C)	107.5 (152.5)	82.5 (127.5)	50.5	8 ⁰ _{-0.009}	No tap	No key				0.4 (0.7)
M3 × 6L					14	1.8	3	3		
C2A□A21 (C2A□A2C)	119.5 (164.5)	94.5 (139.5)	62.5	8 ⁰ _{-0.009}	No tap	No key				0.5 (0.8)
M3 × 6L					14	1.8	3	3		

Note: The models and values in parentheses are for servomotors with holding brakes.
*: When you need the same shaft diameter as the conventional servomotors, contact your Yaskawa representative.

<Shaft End and Other Options>

● With Two Flat Seats

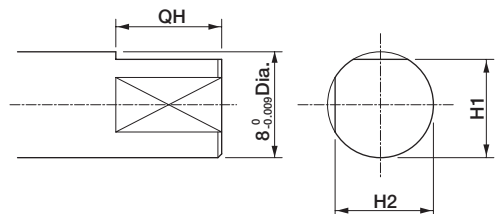

Model SGMAV-	Dimensions of Servomotor with Two Flat Seats		
	QH	H1	H2
A5A□AB□	15	7.5	7.5
O1A□AB□			
C2A□AB□			

● With an Oil Seal

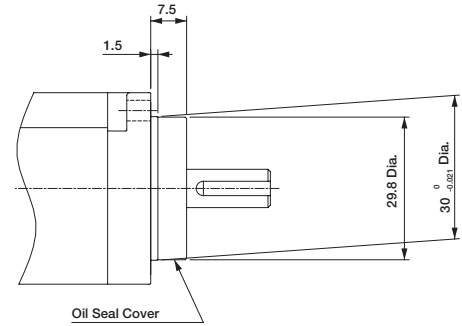

Note: The 7th digit of the model designation is "S" or "E."
The key dimensions are the same as those in the table above.

External Dimensions Units: mm

(2) 200 W to 1.0 kW

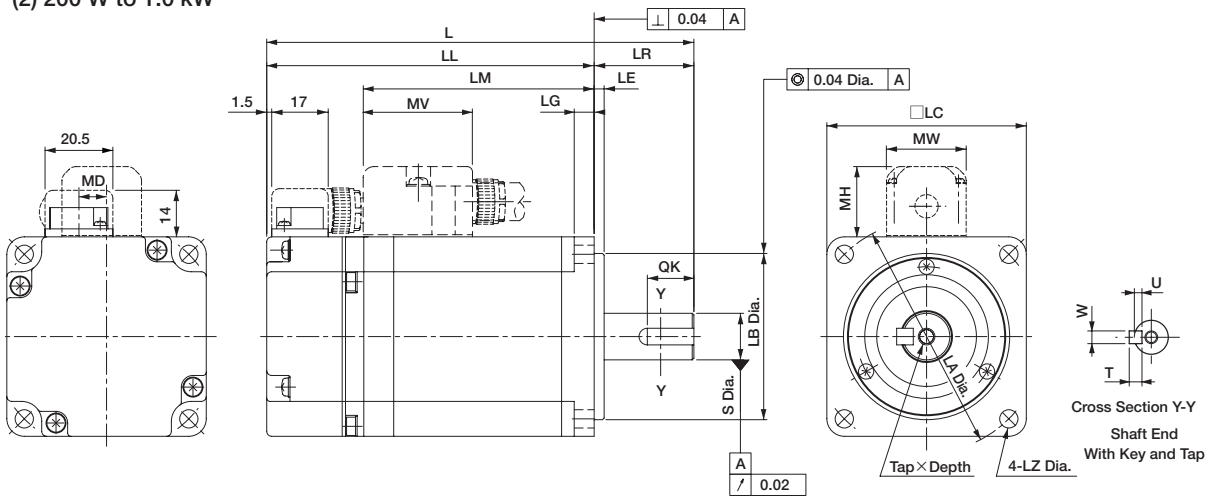

Model SGMAV-	L	LL	LM	Flange Face Dimensions							S	Tap × Depth	Key Dimensions				MD	MW	MH	MV	Approx. Mass kg
				LR	LE	LG	LC	LA	LB	LZ			QK	U	W	T					
02A□A21 (02A□A2C)	110 (150)	80 (120)	51	30	3	6	60	70	50 ⁰ _{-0.025}	5.5	14 ⁰ _{-0.011}	No tap No key				8.5	23.1	20.4	27,8	0.9 (1.5)	
02A□A61 (02A□A6C)												M5×8L	14	3	5						5
04A□A21 (04A□A2C)	128.5 (168.5)	98.5 (138.5)	69.5	30	3	6	60	70	50 ⁰ _{-0.025}	5.5	14 ⁰ _{-0.011}	No tap No key				8.5	23.1	20.4	27,8	1.2 (1.8)	
04A□A61 (04A□A6C)												M5×8L	14	3	5						5
06A□A21 (06A□A2C)	154.5 (200.5)	124.5 (170.5)	95.5	30	3	6	60	70	50 ⁰ _{-0.025}	5.5	14 ⁰ _{-0.011}	No tap No key				8.5	23.1	20.4	27,8	1.7 (2.4)	
06A□A61 (06A□A6C)												M5×8L	14	3	5						5
08A□A21 (08A□A2C)	155 (200)	115 (160)	85	40	3	8	80	90	70 ⁰ _{-0.030}	7	19 ⁰ _{-0.013} *	No tap No key				13.8	30	21.6	23,5	2.6 (3.2)	
08A□A61 (08A□A6C)												M6×10L	22	3.5	6						6
10A□A21 (10A□A2C)	185 (235)	145 (195)	115	40	3	8	80	90	70 ⁰ _{-0.030}	7	19 ⁰ _{-0.013} *	No tap No key				13.8	30	21.6	23,5	3.6 (4.6)	
10A□A61 (10A□A6C)												M6×10L	22	3.5	6						6

Note: The models and values in parentheses are for servomotors with holding brakes.

*: When you need the same shaft diameter as the conventional servomotors, contact your Yaskawa representative.

<Shaft End and Other Options>

●With Two Flat Seats

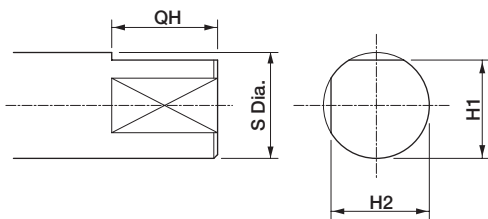

Model SGMAV-	Dimensions of Servomotor with Two Flat Seats			
	QH	S	H1	H2
02A□AB□	14	14 ⁰ _{-0.011}	13	13
04A□AB□				
06A□AB□				
08A□AB□	22	19 ⁰ _{-0.013}	18	18
10A□AB□				

●With an Oil Seal

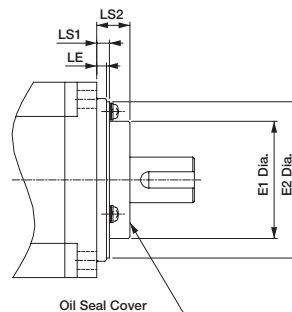

Model SGMAV-	Dimensions of Servomotor with an Oil Seal			
	E1	E2	LS1	LS2
02A, 04A, 06A	36	48	4	10
08A, 10A	49	66	6	11

Note: The 7th digit of the model designation is "S" or "E."
The key dimensions are the same as those in the table above.

Selecting Cables

● Cables Connections

- Standard Wiring (Max. encoder cable length: 20 m)

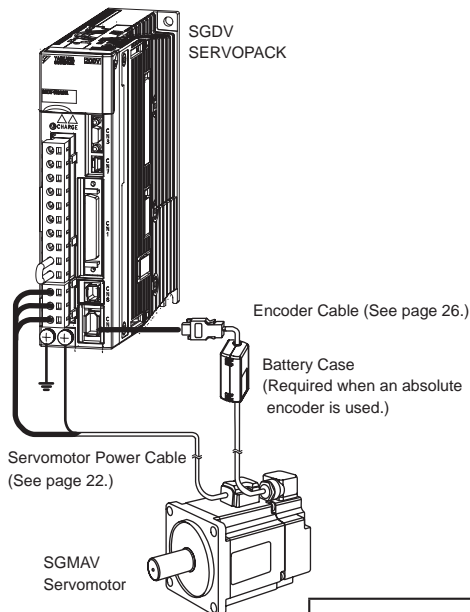

- Encoder Cable Extension from 30 to 50 m

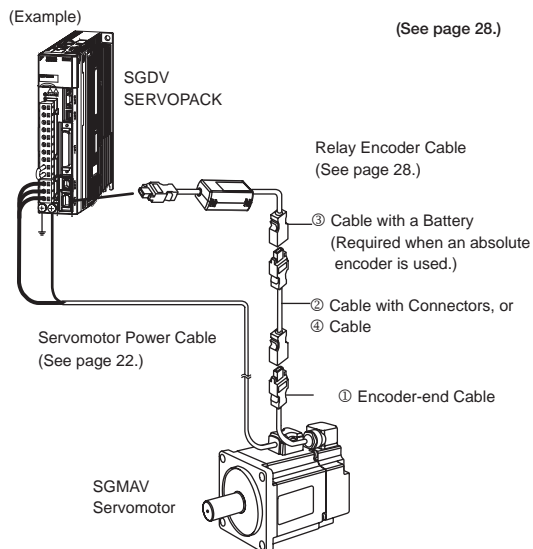

CAUTION

- Separate the servomotor power cable wiring from the I/O signal cable and encoder cable at least 30 cm, and do not bundle or run them in the same duct.
- When the cable length exceeds 20 m, be sure to use a relay encoder cable.
- When the power cable length exceeds 20 m, note that the intermittent duty zone of the Torque-Speed Characteristics will shrink as the line-to-line voltage drops.

● Servomotor Power Cable

Name	Servomotor Rated Output	Length	Order No.		Specifications	Details
			Standard Type	Flexible Type		
For Servomotor without Holding Brakes	50 to 150 W	3 m	JZSP-CSM01-03-E-G#	JZSP-CSM21-03-E-G#		(1)
		5 m	JZSP-CSM01-05-E-G#	JZSP-CSM21-05-E-G#		
		10 m	JZSP-CSM01-10-E-G#	JZSP-CSM21-10-E-G#		
		15 m	JZSP-CSM01-15-E-G#	JZSP-CSM21-15-E-G#		
		20 m	JZSP-CSM01-20-E-G#	JZSP-CSM21-20-E-G#		
	200 to 550 W	3 m	JZSP-CSM02-03-E-G#	JZSP-CSM22-03-E-G#		
		5 m	JZSP-CSM02-05-E-G#	JZSP-CSM22-05-E-G#		
		10 m	JZSP-CSM02-10-E-G#	JZSP-CSM22-10-E-G#		
		15 m	JZSP-CSM02-15-E-G#	JZSP-CSM22-15-E-G#		
		20 m	JZSP-CSM02-20-E-G#	JZSP-CSM22-20-E-G#		
	750 W, 1.0 kW	3 m	JZSP-CSM03-03-E-G#	JZSP-CSM23-03-E-G#		
		5 m	JZSP-CSM03-05-E-G#	JZSP-CSM23-05-E-G#		
		10 m	JZSP-CSM03-10-E-G#	JZSP-CSM23-10-E-G#		
		15 m	JZSP-CSM03-15-E-G#	JZSP-CSM23-15-E-G#		
		20 m	JZSP-CSM03-20-E-G#	JZSP-CSM23-20-E-G#		

Note: The digit "#" of the order number represents the design revision.

(Cont'd)

Selecting Cables

Name	Servomotor Rated Output	Length	Order Nr.		Specifications	Details
			Standard Type	Flexible Type		
For Servomotor with Holding Brakes	50 to 150 W	3 m	JZSP-CSM11-03-E-G#	JZSP-CSM31-03-E-G#		(2)
		5 m	JZSP-CSM11-05-E-G#	JZSP-CSM31-05-E-G#		
		10 m	JZSP-CSM11-10-E-G#	JZSP-CSM31-10-E-G#		
		15 m	JZSP-CSM11-15-E-G#	JZSP-CSM31-15-E-G#		
		20 m	JZSP-CSM11-20-E-G#	JZSP-CSM31-20-E-G#		
	200 to 550 W	3 m	JZSP-CSM12-03-E-G#	JZSP-CSM32-03-E-G#		
		5 m	JZSP-CSM12-05-E-G#	JZSP-CSM32-05-E-G#		
		10 m	JZSP-CSM12-10-E-G#	JZSP-CSM32-10-E-G#		
		15 m	JZSP-CSM12-15-E-G#	JZSP-CSM32-15-E-G#		
		20 m	JZSP-CSM12-20-E-G#	JZSP-CSM32-20-E-G#		
	750 W, 1.0 kW	3 m	JZSP-CSM13-03-E-G#	JZSP-CSM33-03-E-G#		
		5 m	JZSP-CSM13-05-E-G#	JZSP-CSM33-05-E-G#		
		10 m	JZSP-CSM13-10-E-G#	JZSP-CSM33-10-E-G#		
		15 m	JZSP-CSM13-15-E-G#	JZSP-CSM33-15-E-G#		
		20 m	JZSP-CSM13-20-E-G#	JZSP-CSM33-20-E-G#		
Servomotor-end Connector Kit	50 to 150 W		JZSP-CSM9-1-E-G1		Crimped Type (A crimp tool is required.) 	(3)
	200 to 550 W		JZSP-CSM9-2-E-G1			(4)
	750 W, 1.0 kW		JZSP-CSM9-3-E-G1			(5)

Note: The digit "#" of the order number represents the design revision.

(1) Wiring Specifications for Servomotors without Holding Brakes

SERVOPACK-end Leads		Servomotor-end Connector	
Wire Color	Signal	Signal	Pin No.
Green/Yellow	FG	FG	1
Black 1	Phase W	Phase W	2
Black 2	Phase V	Phase V	3
Black 3	Phase U	Phase U	4
		-	5
		-	6

(2) Wiring Specifications for Servomotor with Holding Brakes

SERVOPACK-end Leads		Servomotor-end Connector	
Wire Color	Signal	Signal	Pin No.
Green/Yellow	FG	FG	1
Black 1	Phase W	Phase W	2
Black 2	Phase V	Phase V	3
Black 3	Phase U	Phase U	4
Black 4	Brake	Brake	5
Black 5	Brake	Brake	6
		Shell	FG

Fix shielded cable at servopack end as shown below

Note: No polarity for connection to a holding brake.

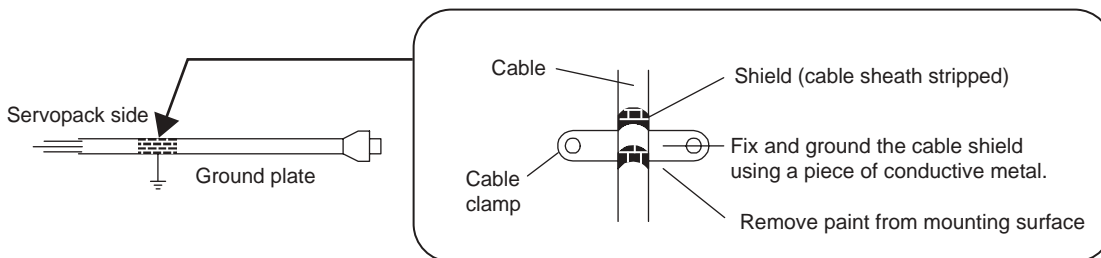

Selecting Cables

(3) Servomotor-end Connector Kit Specifications: For 50 to 150 W Servomotors

Items	Specifications	External Dimensions mm
Order No.	JZSP-CSM9-1-E-G1 (Cables are not included.)	
Applicable Servomotors	SGMAV-A5A, -01A, -C2A	
Manufacturer	J.S.T. Mfg. Co., Ltd.	
Receptacle Housing	J1FSN-06V-K (YE)	
Electrical Contact	SJ1F-01GF-P0.8	
Applicable Wire Size	AWG20 to 24	
Outer Diameter of Insulating Sheath	1.11 dia. to 1.53 dia. mm	
Mounting Screw	M2 Pan-head screw	
Applicable Cable Outer Diameter	7±0.3 dia. mm	

Note: A crimp tool (Model no.: YRS-8841) is required. Contact the respective manufacturer for more information.

(4) Servomotor-end Connector Kit Specifications: For 200 to 550 W Servomotors

Items	Specifications	External Dimensions mm
Order No.	JZSP-CSM9-2-E-G1 (Cables are not included.)	
Applicable Servomotors	SGMAV-02A, -04A, -06A	
Manufacturer	J.S.T. Mfg. Co., Ltd.	
Receptacle Housing	J2FSN-06V-K (YE)	
Electrical Contact	SJ2F-01GF-P1.0	
Applicable Wire Size	AWG20 to 24	
Outer Diameter of Insulating Sheath	1.11 dia. to 1.53 dia. mm	
Mounting Screw	M2 Pan-head screw	
Applicable Cable Outer Diameter	7±0.3 dia. mm	

Note: A crimp tool (Model no.: YRS-8861) is required. Contact the respective manufacturer for more information.

(5) Servomotor-end Connector Kit Specifications: For 750 W, 1.0 kW Servomotors

Items	Specifications	External Dimensions mm
Order No.	JZSP-CSM9-3-E-G1 (Cables are not included.)	
Applicable Servomotors	SGMAV-08A, -10A	
Manufacturer	J.S.T. Mfg. Co., Ltd.	
Receptacle Housing	J3FSN-06V-K (YE)	
Cable Type	Flexible	
Electrical Contact	SJ3F-01GF-P1.8	
Applicable Wire Size	AWG16 to 24	
Outer Diameter of Insulating Sheath	1.53 dia. to 2.5 dia. mm	
Mounting Screw	M2.5 Pan-head screw	
Applicable Cable Outer Diameter	8±0.3 dia. mm	

Note: The following crimp tools are required.
 For power terminals: Model no. YRF-880
 For brake terminals: Model no. YRF-881
 Contact the respective manufacturer for more information.

Selecting Cables

(6) Cable Specifications: For 50 to 550 W Servomotors

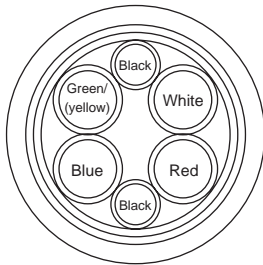

Items	Standard Type	Flexible Type
Order No.	JZSP-CSM90-□□-E (50 m max.)	JZSP-CSM80-□□-E (50 m max.)
Specifications	UL2517 (Rating temperature: 105°C) AWG20×6C For power line: AWG20 (0.52 mm ²) Outer diameter of insulating sheath: 1.53 dia. mm For holding brake line: AWG20 (0.52 mm ²) Outer diameter of insulating sheath: 1.53 dia. mm	UL2517 (Rating temperature: 105°C) AWG22×6C For power line: AWG22 (0.33 mm ²) Outer diameter of insulating sheath: 1.37 dia. mm For holding brake line: AWG22 (0.33 mm ²) Outer diameter of insulating sheath: 1.37 dia. mm
Finished Dimensions	7±0.3 dia. mm	
Internal Configuration and Lead Color		
Yaskawa Standard Specifications (Standard Length)	Cable length: 5 m, 10 m, 15 m, 20 m, 30 m, 40 m, 50 m	

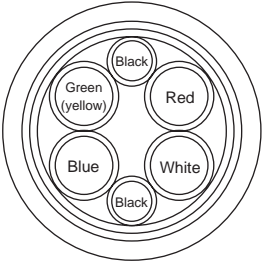
(7) Cable Specifications: For 750 W, 1.0 kW Servomotors

Items	Standard Type	Flexible Type
Order No.	JZSP-CSM91-□□-E (50 m max.)	JZSP-CSM81-□□-E (50 m max.)
Specifications	UL2517 (Rating temperature: 105°C) AWG16×4C, AWG20×2C For power line: AWG16 (1.31 mm ²) Outer diameter of insulating sheath: 2.15 dia. mm For holding brake line: AWG20 (0.52 mm ²) Outer diameter of insulating sheath: 1.6 dia. mm	UL2517 (Rating temperature: 105°C) AWG16×4C, AWG22×2C For power line: AWG16 (1.31 mm ²) Outer diameter of insulating sheath: 2.35 dia. mm For holding brake line: AWG22 (0.33 mm ²) Outer diameter of insulating sheath: 1.37 dia. mm
Finished Dimensions	8±0.3 dia. mm	
Internal Configuration and Lead Color		
Yaskawa Standard Specifications (Standard Length)	Cable length: 5 m, 10 m, 15 m, 20 m, 30 m, 40 m, 50 m	

Selecting Cables

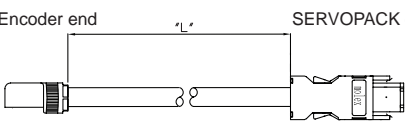
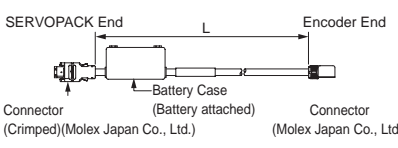
Encoder Cables (Length: 20 m or less)

Name	Length	Order No.		Specifications	Details
		Standard Type	Flexible Type ¹		
Cable with Connectors (For Incremental Encoder)	3 m	JZSP-CSP01-03-E-G#	JZSP-CSP21-03-G#	Encoder end  SERVOPACK end	(1)
	5 m	JZSP-CSP01-05-E-G#	JZSP-CSP21-05-G#		
	10 m	JZSP-CSP01-10-E-G#	JZSP-CSP21-10-G#		
	15 m	JZSP-CSP01-15-E-G#	JZSP-CSP21-15-G#		
	20 m	JZSP-CSP01-20-E-G#	JZSP-CSP21-20-G#		
Cable with Connectors ² (For Absolute Encoder, with a Battery Case)	3 m	JZSP-CSP05-03-E-G#	JZSP-CSP25-03-G#	SERVOPACK End  Encoder End	(2)
	5 m	JZSP-CSP05-05-E-G#	JZSP-CSP25-05-G#		
	10 m	JZSP-CSP05-10-E-G#	JZSP-CSP25-10-G#		
	15 m	JZSP-CSP05-15-E-G#	JZSP-CSP25-15-G#		
	20 m	JZSP-CSP05-20-E-G#	JZSP-CSP25-20-G#		
SERVOPACK-end Connector Kit		JZSP-CMP9-1-E		Soldered 	(3)
Encoder-end Connector Kit		JZSP-CSP9-2-E		Crimped Type (A crimp tool is required.) 	

*1: Use flexible cables for movable sections such as robot arms.

*2: When the battery is connected to the host controller, no battery case is required. If so, use a cable for incremental encoders.

Note: The digit "#" of the order number represents the design revision.

(1) Wiring Specifications for Cable with Connectors
(For incremental encoder)

Flexible Type

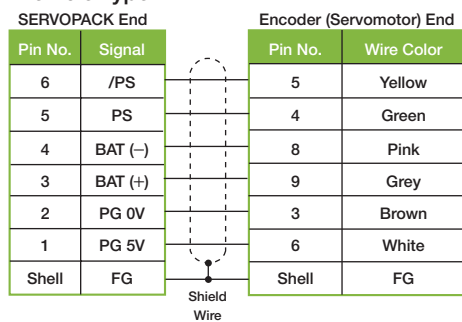

(2) Wiring Specifications for Cable with Connectors
(For absolute encoder, with a battery case)

Flexible Type

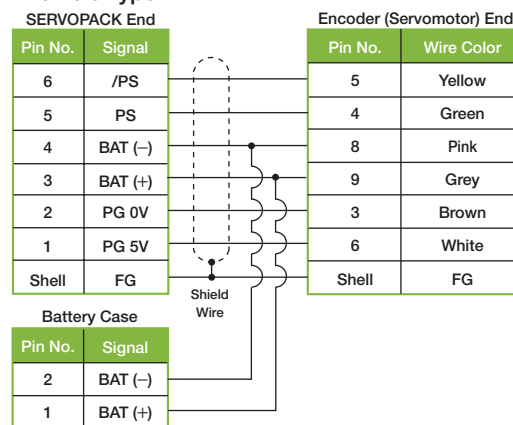

Selecting Cables

(3) SERVOPACK-end/Encoder-end Connector Kit Specifications

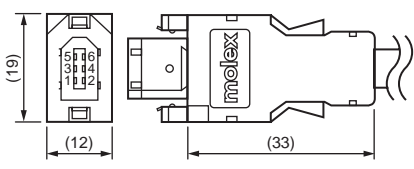
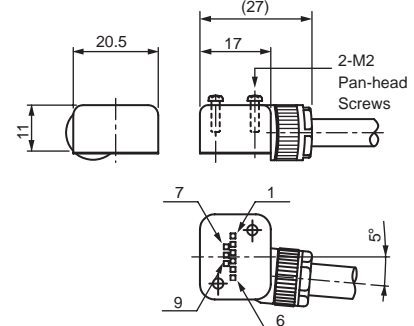
Items	SERVOPACK-end Connector Kit	Encoder-end Connector Kit
Order No.	JZSP-CMP9-1-E (Cables are not included.)	JZSP-CSP9-2-E (Cables are not included.)
Manufacturer	Molex Japan Co., Ltd.	Molex Japan Co., Ltd.
Specifications	55100-0670 (soldered) Product Specification: PS-54280	54346-0070 (crimped) Mounting screw: M2 pan-head screw (×2) Outer diameter of applicable cable: 6.3 dia. to 7.7 dia. mm Applicable wire size: AWG22 to 26 Outer diameter of insulating sheath: 1.05 dia. to 1.4 dia. mm Application Specification: AS-54992 Crimping Specification: CS-56161
External Dimensions mm		

*: A crimp tool is required.
The following crimp tool is applicable for the cables provided by Yaskawa. When using other wire sizes, contact the respective manufacturer for crimp tools.
Applicable crimp tool for Yaskawa's wire size: Hand Tool Model No. 57175-5000

(4) Cable Specifications

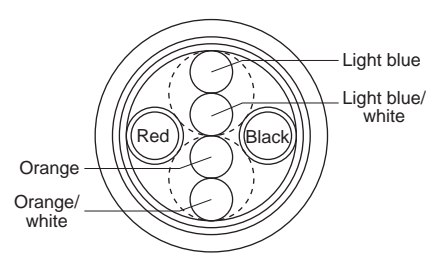
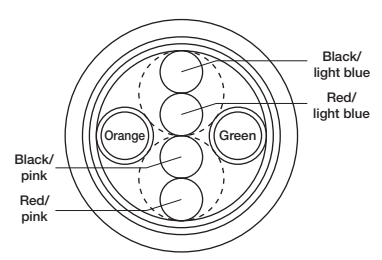
Items	Standard Type	Flexible Type
Order No.	JZSP-CMP09-□□-E	JZSP-CSP39-□□-E
Cable Length	20 m max.	
Specifications	UL20276 (Rating temperature: 80°C) AWG22×2C+AWG24×2P AWG22 (0.33 mm ²) Outer diameter of insulating sheath: 1.15 dia. mm AWG24 (0.20 mm ²) Outer diameter of insulating sheath: 1.09 dia. mm	UL20276 (Rating temperature: 80°C) AWG22×2C+AWG24×2P AWG22 (0.33 mm ²) Outer diameter of insulating sheath: 1.35 dia. mm AWG24 (0.20 mm ²) Outer diameter of insulating sheath: 1.21 dia. mm
Finished Dimensions	6.5 dia. mm	6.8 dia. mm
Internal Configuration and Lead Color		
Yaskawa Standards Specifications (Standard Length)	Cable length: 5 m, 10 m, 15 m, 20 m	

Selecting Cables

● Relay Encoder Cables (For extending from 30 to 50 m)

Name	Length	Order No. Standard Type	Specifications	Details
① Encoder-end Cables (For incremental and absolute encoder)	0.3 m	JZSP-CSP11-E	<p>SERVOPACK End 0.3 m Encoder End Plug Connector (Crimped) (Molex Japan Co., Ltd.) Connector (Molex Japan Co., Ltd.)</p>	(1)
② Cable with Connectors (For incremental and absolute encoder)	30 m	JZSP-UCMP00-30-E	<p>SERVOPACK End L Encoder End Plug Connector (Crimped) (Molex Japan Co., Ltd.) Socket Connector (Soldered) (Molex Japan Co., Ltd.)</p>	(2)
	40 m	JZSP-UCMP00-40-E		
	50 m	JZSP-UCMP00-50-E		
③ Cable with a Battery Case (Required when an absolute encoder is used*)	0.3 m	JZSP-CSP12-E	<p>SERVOPACK End 0.3 m Encoder End Plug Connector (Crimped) (Molex Japan Co., Ltd.) Battery Case (Battery attached) Socket Connector (Soldered) (Molex Japan Co., Ltd.)</p>	(3)
④ Cables	30 m	JZSP-CMP19-30-E		(4)
	40 m	JZSP-CMP19-40-E		
	50 m	JZSP-CMP19-50-E		

*: Not required when connecting a battery to the host controller.

(1) Wiring Specifications for Encoder-end Cable

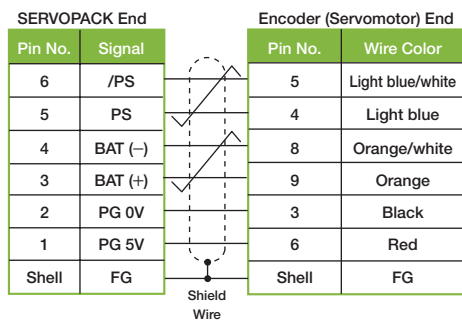

(2) Wiring Specifications for Cable with Connectors

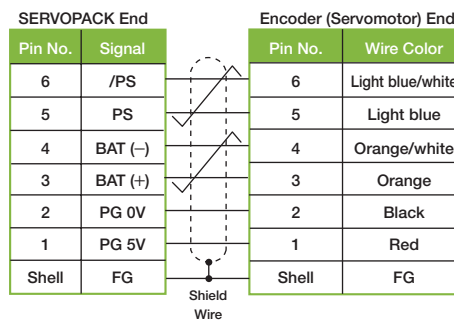

Selecting Cables

(3) Wiring Specifications for Cable with a Battery Case

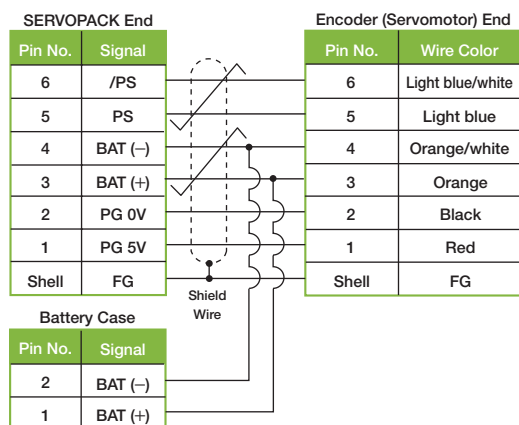

(4) Cable Specifications

Item	Standard Type
Order No.*	JZSP-CMP19-□□-E
Cable Length	50 m max.
Specifications	UL20276 (Rating temperature: 80°C) AWG16×2C+AWG26×2P AWG16 (1.31 mm ²) Outer diameter of insulating sheath: 2.0 dia. mm AWG26 (0.13 mm ²) Outer diameter of insulating sheath: 0.91 dia. mm
Finished Dimensions	6.8 dia. mm
Internal Configuration and Lead Colors	
Yaskawa Standard Specifications (Standard Length)	Cable length: 30 m, 40 m, 50 m

*: Specify the cable length in □□ of order no.
Example: JZSP-CMP19-30-E (30 m)

