

Rotary Servomotors

SGMSV

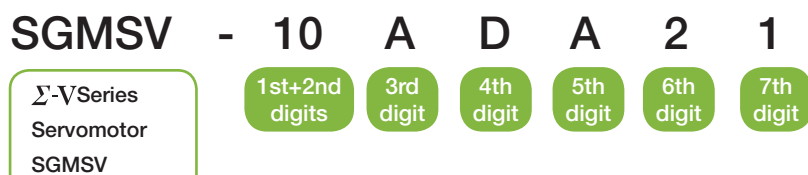

Model Designations



1st+2nd digits Rated Output

Code	Specifications
10	1.0 kW
15	1.5 kW
20	2.0 kW
25	2.5 kW
30	3.0 kW
40	4.0 kW
50	5.0 kW
70	7.0 kW*

*: Available only for 200-VAC models.

3rd digit Power Supply Voltage

Code	Specifications
A	200 VAC
D	400 VAC

4th digit Serial Encoder

Code	Specifications
3	20-bit absolute (standard)
D	20-bit incremental (standard)

5th digit Design Revision Order

Code	Specifications
A	Standard

6th digit Shaft End

Code	Specifications
2	Straight without key (standard)
6	Straight with key and tap (optional)

7th digit Options

Code	Specifications
1	Without options (not used in Europe)
F	With dust seal
H	With dust seal and holding brake (24 VDC)
E	With oil seal and holding brake (24 VDC)
S	With oil seal

Features

- Super high power
- Wide selection: 1.0 kW to 7.0 kW capacity, holding brake option
- Mounted serial encoder: 20 bits, high resolution
- Protective structure: IP67 (Not including the IP22 compliant enclosure for 7.0 kW motor)

Application Examples

- Chip mounters
- PCB drilling stations
- Machine tool feeders

Configurations of connectors for the main circuit



SGMSV-10 to -70

The connectors for these models are round. The connectors specified by Yaskawa are required. Note that the connectors vary depending on the operation environment of servomotors.

Two types of connectors are available.

- Standard connectors
For details, refer to page 78 to 80.
- Protective structure IP67 and European Safety Standards compliant connectors
For details, refer to page 81 and 82.

Ratings and Specifications

Time Rating: Continuous

Vibration Class: V15

Insulation Resistance: 500 VDC, 10 MΩ min.

Ambient Temperature: 0 to 40°C

Excitation: Permanent magnet

Mounting: Flange-mounted

Thermal Class: F

Withstand Voltage: 1500 VAC for one minute (200-V class)
1800 VAC for one minute (400-V class)

Enclosure: Totally enclosed, self-cooled, IP67
(except for shaft opening)

Note: IP22 for SGMSV-70 servomotors.

Ambient Humidity: 20% to 80% (no condensation)

Drive Method: Direct drive

Rotation Direction: Counterclockwise (CCW) with forward run
reference when viewed from the load side

200-V Class

Servomotor Model: SGMSV-□□□		10A	15A	20A	25A	30A	40A	50A	70A
Rated Output*	kW	1.0	1.5	2.0	2.5	3.0	4.0	5.0	7.0
Rated Torque*	Nm	3.18	4.90	6.36	7.96	9.80	12.6	15.8	22.3
Instantaneous Peak Torque*	Nm	9.54	14.7	19.1	23.9	29.4	37.8	47.6	54
Rated Current*	Arms	5.7	9.3	12.1	13.8	17.9	25.4	27.6	38.3
Instantaneous Max. Current*	Arms	17	28	42	44.5	56	77	84	105
Rated Speed*	min ⁻¹	3000							
Max. Speed*	min ⁻¹	6000	5000						
Torque Constant	Nm/Arms	0.636	0.590	0.561	0.610	0.582	0.519	0.604	0.604
Rotor Moment of Inertia	×10 ⁻⁴ kgm ²	1.74 (1.99)	2.00 (2.25)	2.47 (2.72)	3.19 (3.44)	7.00 (9.2)	9.60 (11.8)	12.3 (14.5)	12.3
Rated Power Rate*	kW/s	58 (51)	120 (107)	164 (149)	199 (184)	137 (104)	165 (135)	203 (172)	404
Rated Angular Acceleration*	rad/s ²	18300 (16000)	24500 (21800)	25700 (23400)	25000 (23100)	14000 (10700)	13100 (10700)	12800 (10900)	18100
Applicable SERVOPACK	SGDV-□□□□	7R6A	120A	180A	200A	200A	330A	330A	550A

*: These items and torque-motor speed characteristics quoted in combination with a SERVOPACK are at an armature winding temperature of 20°C.

Notes: 1 The values in parentheses are for servomotors with holding brakes.

2 The above specifications show the values under the cooling condition when the following heat sinks are mounted on the servomotors.

SGMSV-10A/-15A/-20A/-25A : 300 mm×300 mm×12 mm (aluminum)

SGMSV-30A/-40A/-50A/-70A : 400 mm×400 mm×20 mm (aluminum)

400-V Class

Servomotor Model: SGMSV-□□□		10D	15D	20D	25D	30D	40D	50D
Rated Output*	kW	1.0	1.5	2.0	2.5	3.0	4.0	5.0
Rated Torque*	Nm	3.18	4.9	6.36	7.96	9.8	12.6	15.8
Instantaneous Peak Torque*	Nm	9.54	14.7	19.1	23.9	29.4	37.8	47.6
Rated Current*	Arms	2.8	4.7	6.1	7.4	8.9	12.5	13.8
Instantaneous Max. Current*	Arms	8.5	14	20	25	28	38	42
Rated Speed*	min ⁻¹	3000						
Max. Speed*	min ⁻¹	6000	5000					
Torque Constant	Nm/Arms	1.27	1.23	1.18	1.15	1.16	1.06	1.21
Rotor Moment of Inertia	×10 ⁻⁴ kgm ²	1.74 (1.99)	2.00 (2.25)	2.47 (2.72)	3.19 (3.44)	7.00 (9.2)	9.60 (11.8)	12.3 (14.5)
Rated Power Rate*	kW/s	58 (51)	120 (107)	164 (149)	199 (184)	137 (104)	165 (135)	203 (172)
Rated Angular Acceleration*	rad/s ²	18300 (16000)	24500 (21800)	25700 (23400)	25000 (23100)	14000 (10700)	13100 (10700)	12800 (10900)
Applicable SERVOPACK	SGDV-□□□□	3R5D	5R4D	8R4D	120D	120D	170D	170D

*: These items and torque-speed characteristics quoted in combination with a SERVOPACK are at an armature winding temperature of 20°C.

Notes: 1 The values in parentheses are for servomotors with holding brakes.

2 The above specifications show the values under the cooling condition when the following heat sinks are mounted on the servomotors.

SGMSV-10D/-15D/-20D/-25D: 300 mm × 300 mm × 12 mm (aluminum)

SGMSV-30D/-40D/-50D : 400 mm × 400 mm × 20 mm (aluminum)

Ratings and Specifications

● Torque-Speed Characteristics (200 V/400 V) **A**: Continuous Duty Zone **B**: Intermittent Duty Zone

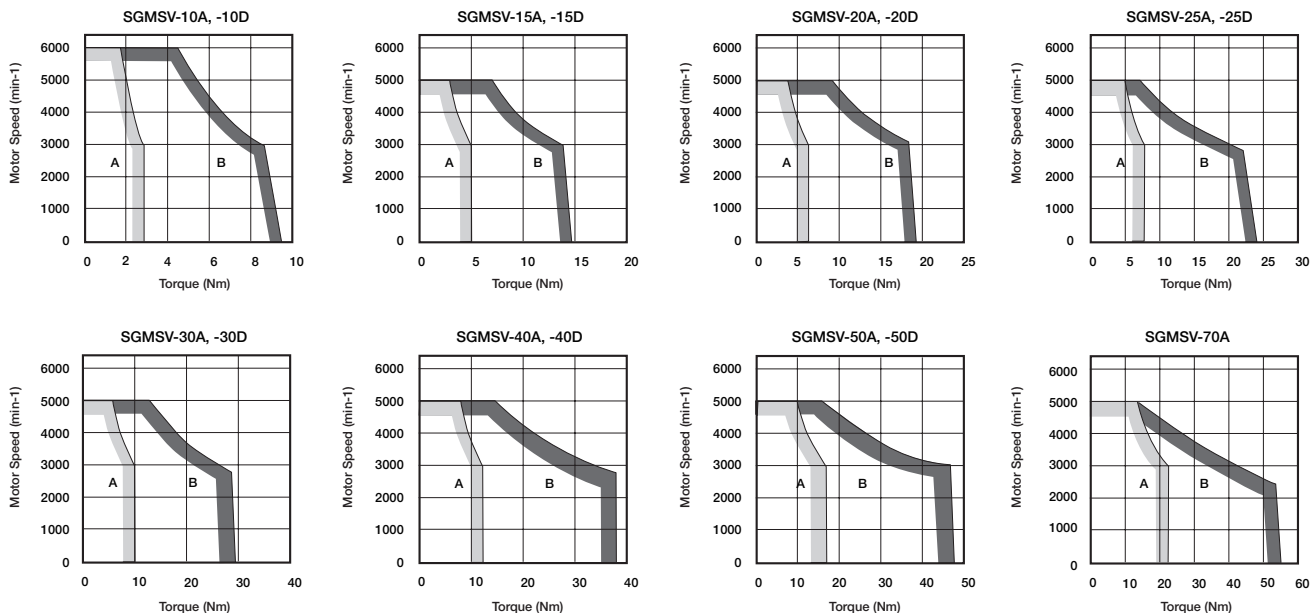

Notes: 1 When the effective torque is within the rated torque, the servomotor can be used within the intermittent duty zone.
 2 When the power cable length exceeds 20 m, note that the intermittent duty zone of the *Torque-Speed Characteristics* will shrink as the line-to-line voltage drops.

● Holding Brake Electrical Specifications

Servomotor Model	Servomotor Rated Output kW	Holding Brake Specifications		
		Holding Torque Nm	Rated Voltage 24 VDC	
			Capacity W	Rated Current A (at 20°C)
SGMSV-10	1.0	7.84	12	0.5
SGMSV-15	1.5	7.84	12	0.5
SGMSV-20	2.0	7.84	12	0.5
SGMSV-25	2.5	10	12	0.5
SGMSV-30	3.0	20	10	0.41
SGMSV-40	4.0	20	10	0.41
SGMSV-50	5.0	20	10	0.41

Notes: 1 The holding brake is only used to hold the load and cannot be used to stop the servomotor.
 2 The holding brake open time and holding brake operation time vary depending on which discharge circuit is used. Make sure holding brake open time and holding brake operation time are correct for your servomotor.
 3 A 24 VDC power supply is to be provided by customers.

Ratings and Specifications

● Allowable Load Moment of Inertia at the Motor Shaft

The rotor moment of inertia ratio is the value for a servomotor without a gear and a holding brake.

Servomotor Model	Servomotor Rated Output	Allowable Load Moment of Inertia (Rotor Moment of Inertia Ratio)
SGMSV-10 to -70	1.0 to 7.0 kW	5 times

● Load Moment of Inertia

The larger the load moment of inertia, the worse the movement response.

The allowable load moment of inertia (J_L) depends on the motor capacity, as shown above. This value is provided strictly as a guideline and results may vary depending on servomotor drive conditions.

Use the AC servo drive capacity selection program SigmaJunmaSize+ to check the operation conditions. The program can be downloaded for free from our web site (<http://www.yaskawa.eu.com>).

An overvoltage alarm (A.400) is likely to occur during deceleration if the load moment of inertia exceeds the allowable load moment of inertia. SERVOPACKs with a built-in regenerative resistor may generate a regenerative overload alarm (A.320). Take one of the following steps if this occurs.

- Reduce the torque limit.
- Reduce the deceleration rate.
- Reduce the maximum speed.
- Install an external regenerative resistor if the alarm cannot be cleared using the steps above. Refer to *Regenerative Resistors* on page 364.

● Allowable Radial and Thrust Loads

Design the mechanical system so thrust and radial loads applied to the servomotor shaft end during operation fall within the ranges shown in the table.

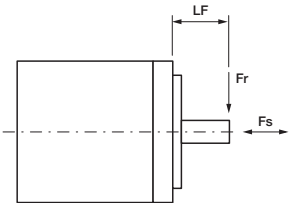
Servomotor Model	Allowable Radial Load (F_r) N	Allowable Thrust Load (F_s) N	LF mm	Reference Diagram	
SGMSV-	10□□A21	686	196	45	
	15□□A21				
	20□□A21				
	25□□A21	980	392	63	
	30□□A21				
	40□□A21				
	50□□A21				
70□□A21	1176				

External Dimensions Units: mm

● Without Holding Brakes

(1) 1.0 to 5.0 kW

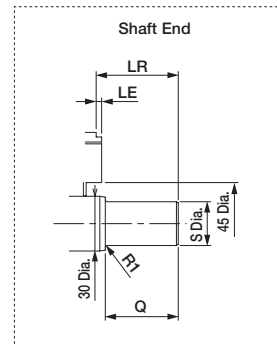
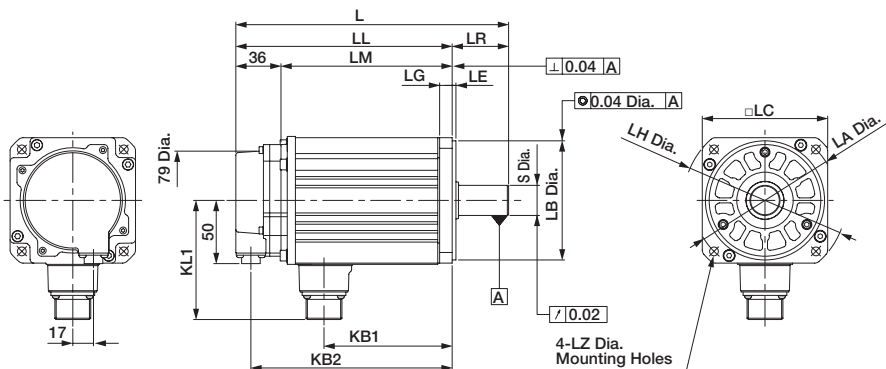

Note: For the specifications of the other shaft ends, refer to page 76.

Model SGMSV-	L	LL	LM	LR	KB1	KB2	KL1	Flange Face Dimensions								Shaft End Dimensions		Approx. Mass kg
								LA	LB	LC	LE	LF	LG	LH	LZ	S	Q	
10□□A21	192	147	111	45	76	135	96	115	95 ⁰ _{-0.035}	100	3	3	10	130	7	24 ⁰ _{-0.013}	40	4.1
15□□A21	202	157	121	45	86	145	96	115	95 ⁰ _{-0.035}	100	3	3	10	130	7	24 ⁰ _{-0.013}	40	4.6
20□□A21	218	173	137	45	102	161	96	115	95 ⁰ _{-0.035}	100	3	3	10	130	7	24 ⁰ _{-0.013}	40	5.4
25□□A21	241	196	160	45	125	184	96	115	95 ⁰ _{-0.035}	100	3	3	10	130	7	24 ⁰ _{-0.013}	40	6.8
30□□A21	259	196	160	63	124	184	114	145	110 ⁰ _{-0.035}	130	6	6	12	165	9	28 ⁰ _{-0.013}	55	10.5
40□□A21	296	233	197	63	161	221	114	145	110 ⁰ _{-0.035}	130	6	6	12	165	9	28 ⁰ _{-0.013}	55	13.5
50□□A21	336	273	237	63	201	261	114	145	110 ⁰ _{-0.035}	130	6	6	12	165	9	28 ⁰ _{-0.013}	55	16.5

Note: Models with oil seals are of the same configuration.

• Cable Specifications for Encoder-end Connector (20-bit Encoder)

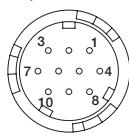

Receptacle: CM10-R10P-D
 Applicable plug (To be provided by the customer)
 Plug: CM10-AP10S-□-D (L-shaped)
 CM10-SP10S-□-D (Straight)
 (Boxes □ indicate a value that varies, depending on cable size.)
 Manufacturer: DDK Ltd.

With an Absolute Encoder

1	PS	6	BAT (+)
2	/PS	7	-
3	-	8	-
4	PG 5V	9	PG 0V
5	BAT (-)	10	FG (Frame ground)

With an Incremental Encoder

1	PS	6	-
2	/PS	7	-
3	-	8	-
4	PG 5V	9	PG 0V
5	-	10	FG (Frame ground)

• Cable Specifications for Servomotor-end Connector

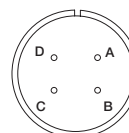

A	Phase U
B	Phase V
C	Phase W
D	FG (Frame ground)

- SGMSV-10 to -25
Manufacturer: DDK Ltd.
- SGMSV-30 to -50
Manufacturer: Japan Aviation Electronics Industry, Ltd.

External Dimensions Units: mm

(2) 7.0 kW (only for 200 V servomotors)

Note: Leave a minimum space of 70 mm around the servomotor to allow for a sufficient amount of cooling air.

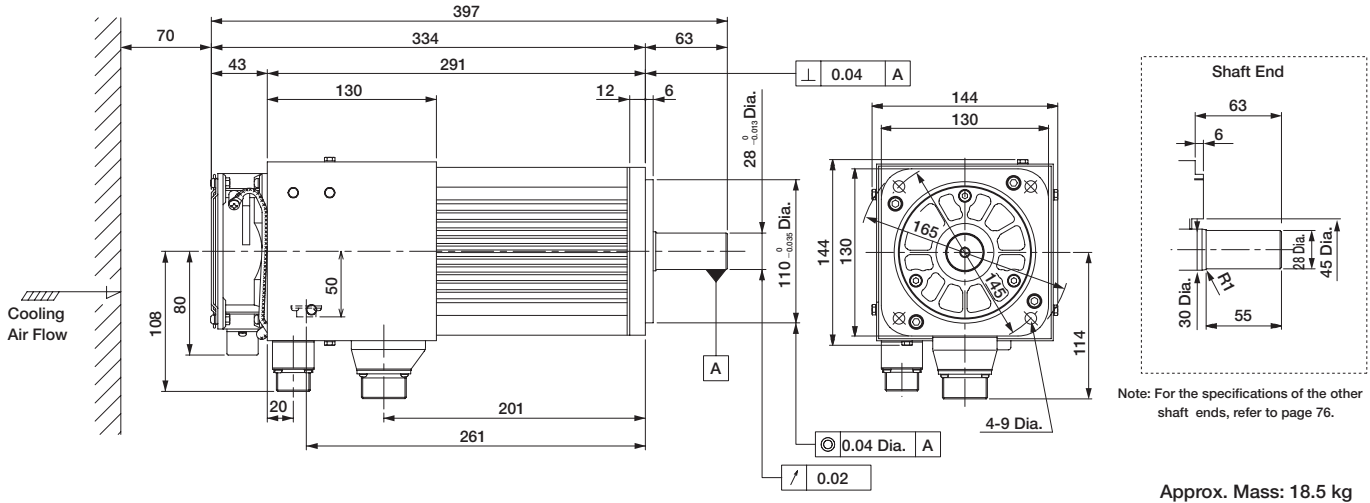

Approx. Mass: 18.5 kg

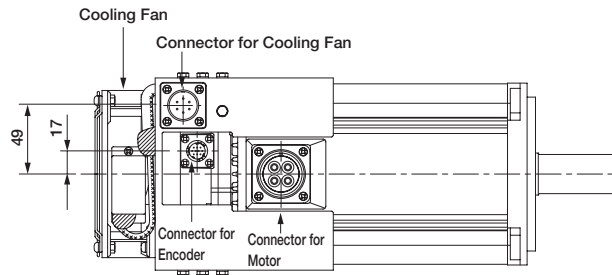

- Specifications of Cooling Fan**
 Single-phase 220 V
 50/60 Hz
 17/15 W
 0.11/0.09 A
- Specifications of rotation error detector**
 Contact Capacity:
 Max. allowable voltage: 350 V (AC, DC)
 Max. allowable current: 120 mA (AC, DC)
 Max. controllable power: 360 mW
 Alarm Contact:
 ON at normal fan rotation.
 OFF at 1680±100 min-1 or less.
 (OFF during 3 seconds at start-up)

• Cable Specifications for Servomotor-end Connector

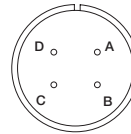

A	Phase U
B	Phase V
C	Phase W
D	FG (Frame ground)

Manufacturer: Japan Aviation Electronics Industry, Ltd.

• Cable Specifications for Fan-end Connector

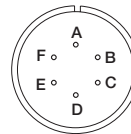

Receptacle: MS3102A14S-6P
 Applicable plug
 Plug: MS3108B14S-6S
 Cable clamp: MS3057-6A

Note: Servomotor-end connectors (receptacles) are RoHS-compliant. Contact the respective connector manufacturers for RoHS-compliant cable-end connectors.

A	Fan motor
B	Fan motor
C	-
D	Alarm terminal
E	Alarm terminal
F	FG (Frame ground)

• Cable Specifications for Encoder-end Connector (20-bit Encoder)

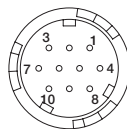

Receptacle: CM10-R10P-D
 Applicable plug (To be provided by the customer)
 Plug: CM10-SP10S-□-D (Straight)
 (Boxes □ indicate a value that varies, depending on cable size.)
 Use straight plugs to avoid interference with the fan cover.
 Manufacturer : DDK Ltd.

With an Absolute Encoder

1	PS	6	BAT (+)
2	/PS	7	-
3	-	8	-
4	PG 5V	9	PG 0V
5	BAT (-)	10	FG (Frame ground)

With an Incremental Encoder

1	PS	6	-
2	/PS	7	-
3	-	8	-
4	PG 5V	9	PG 0V
5	-	10	FG (Frame ground)

External Dimensions Units: mm

● With Holding Brakes

(1) 1.0 to 5.0 kW

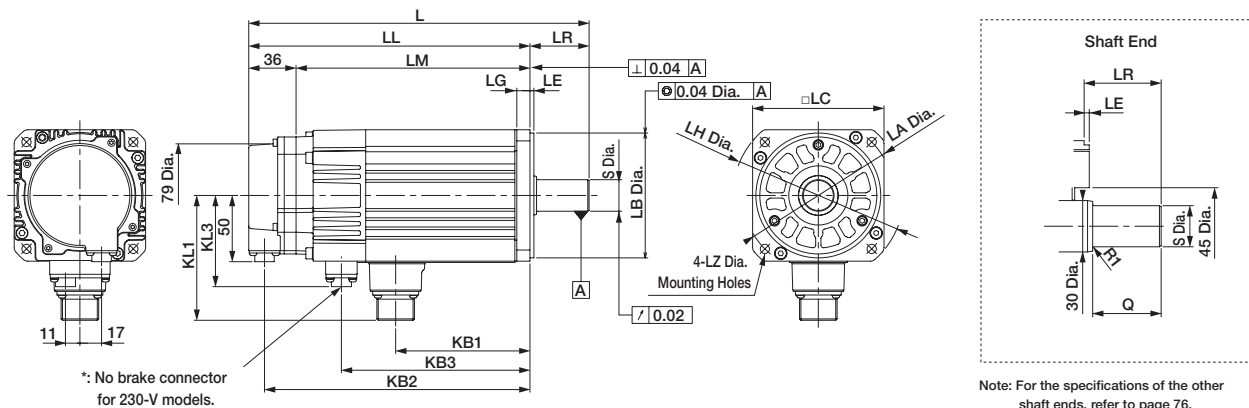

Model SGMSV-	L	LL	LM	LR	KB1			KB3*	KL1			Flange Face Dimensions							Shaft End Dimensions		Approx. Mass kg	
					200V	400V	KB2		400V	200V	400V	400V	LA	LB	LC	LE	LF	LG	LH	LZ		S
10 □ □ A2 □	233	188	152	45	67	76	176	118	102	96	69	115	95 ⁰ _{-0.035}	100	3	3	10	130	7	24 ⁰ _{-0.013}	40	5.5
15 □ □ A2 □	243	198	162	45	77	86	186	128	102	96	69	115	95 ⁰ _{-0.035}	100	3	3	10	130	7	24 ⁰ _{-0.013}	40	6
20 □ □ A2 □	259	214	178	45	93	102	202	144	102	96	69	115	95 ⁰ _{-0.035}	100	3	3	10	130	7	24 ⁰ _{-0.013}	40	6.8
25 □ □ A2 □	292	247	211	45	116	125	225	177	102	96	69	115	95 ⁰ _{-0.035}	100	3	3	10	130	7	24 ⁰ _{-0.013}	40	8.7
30 □ □ A2 □	295	232	196	63	114	124	220	176	119	114	81	145	110 ⁰ _{-0.035}	130	6	6	12	165	9	28 ⁰ _{-0.013}	55	13
40 □ □ A2 □	332	269	233	63	151	161	257	213	119	114	81	145	110 ⁰ _{-0.035}	130	6	6	12	165	9	28 ⁰ _{-0.013}	55	16
50 □ □ A2 □	372	309	273	63	191	201	297	253	119	114	81	145	110 ⁰ _{-0.035}	130	6	6	12	165	9	28 ⁰ _{-0.013}	55	19

*: No brake connector for 200-V models (there are brake terminals on the servomotor-end connectors).
 Note: Models with oil seals are of the same configuration.

● Cable Specifications for Encoder-end Connector (20-bit Encoder)

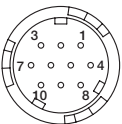

Receptacle: CM10-R10P-D
 Applicable plug (To be provided by the customer)
 Plug: CM10-AP10S-□-D (L-shaped)
 CM10-SP10S-□-D (Straight)
 (Boxes □ indicate a value that varies, depending on cable size.)
 Manufacturer: DDK Ltd.

With an Absolute Encoder

1	PS	6	BAT (+)
2	/PS	7	-
3	-	8	-
4	PG 5V	9	PG 0V
5	BAT (-)	10	FG (Frame ground)

With an Incremental Encoder

1	PS	6	-
2	/PS	7	-
3	-	8	-
4	PG 5V	9	PG 0V
5	-	10	FG (Frame ground)

200-V Class

● Cable Specifications for Servomotor-end Connector

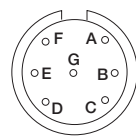

A	Phase U
B	Phase V
C	Phase W
D	FG (Frame ground)
E	Brake terminal
F	Brake terminal
G	-

Manufacturer: Japan Aviation Electronics Industry, Ltd.

Note: No polarity for connection to the brake terminals

400-V Class

● Cable Specifications for Servomotor-end Connector

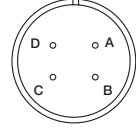

A	Phase U
B	Phase V
C	Phase W
D	FG (Frame ground)

● SGMSV-10 to -25
 Manufacturer: DDK Ltd.
 ● SGMSV-30 to -50
 Manufacturer: Japan Aviation Electronics Industry, Ltd.

● Cable Specifications for Brake-end Connector

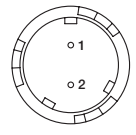

Receptacle: CM10-R2P-D
 Applicable plug (To be provided by the customer)
 Plug: CM10Y-AP2S-□-D-G1 (L-shaped)
 CM10-SP2S-□-D (Straight)
 (Boxes □ indicate a value that varies, depending on cable size.)
 Manufacturer: DDK Ltd.

Brake terminal
Brake terminal

Note: No polarity for connection to the brake terminals

External Dimensions Units: mm

● Shaft End

SGMSV - □□□□□□□

Code	Specifications	Remarks
2	Straight without key	Standard
6	Straight with key and tap for one location (Key slot is JIS B1301-1996 fastening type)	Optional

Code	Specifications	Shaft End	Model SGMSV-								
			10	15	20	25	30	40	50	70	
2	Straight without Key		LR	45				63			
			Q	40				55			
			S	24 ⁰ _{-0.013}				28 ⁰ _{-0.013}			
6	Straight with Key and Tap		LR	45				63			
			Q	40				55			
			QK	32				50			
			S	24 ⁰ _{-0.013}				28 ⁰ _{-0.013}			
			W	8							
			T	7							
			U	4							
P	M8 Screw Depth16										

Selecting Cables

● Cables Connections

- Standard Wiring (Max. encoder cable length: 20 m)

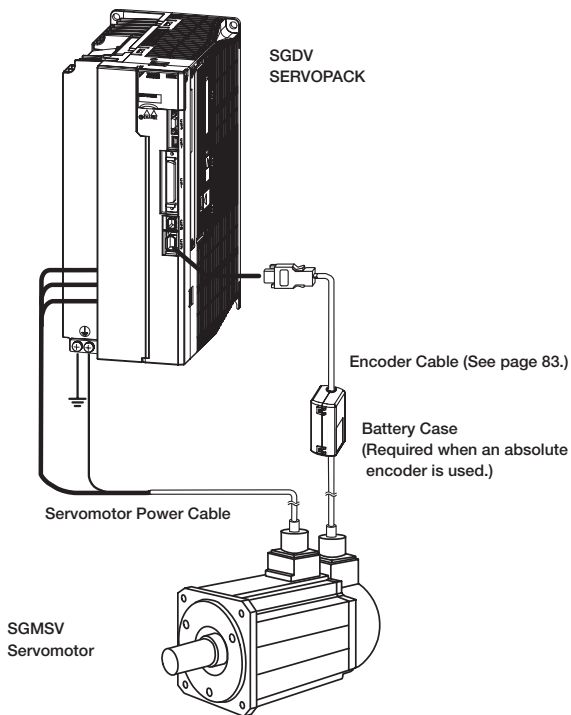

- Encoder Cable Extension from 30 to 50 m

(See page 85.)

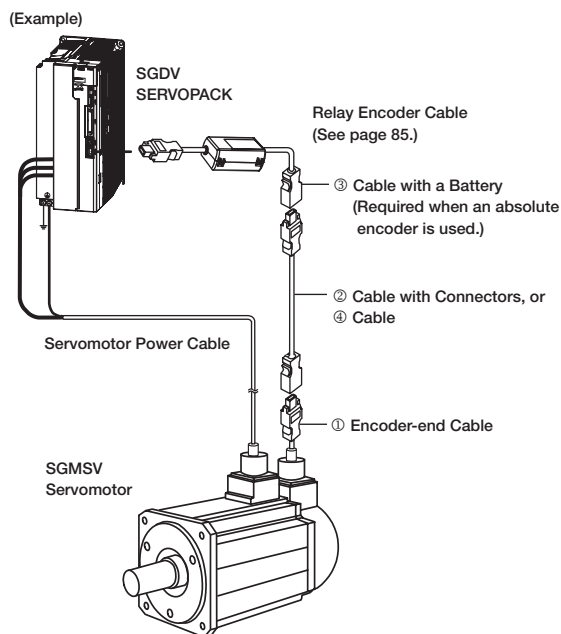

⚠ CAUTION

- Separate the servomotor power cable wiring from the I/O signal cable and encoder cable at least 30 cm, and do not bundle or run them in the same duct.
- When the power cable length exceeds 20 m, note that the intermittent duty zone of the *Torque-Speed Characteristics* will shrink as the line-to-line voltage drops.

● Servomotor Power Cable (400-V Class)

Name	Servomotor Rated Output	Length	Order No.	Specifications	Details
			Flexible Type		
For Servomotor without Holding Brakes	1.0 kW to 1.5 kW	3 m	JZSP-CVMCA11-03-E-G#		(1)
		5 m	JZSP-CVMCA11-05-E-G#		
		10 m	JZSP-CVMCA11-10-E-G#		
		15 m	JZSP-CVMCA11-15-E-G#		
		20 m	JZSP-CVMCA11-20-E-G#		
	2.0 kW to 2.5 kW	3 m	JZSP-CVMCA12-03-E-G#		
		5 m	JZSP-CVMCA12-05-E-G#		
		10 m	JZSP-CVMCA12-10-E-G#		
		15 m	JZSP-CVMCA12-15-E-G#		
		20 m	JZSP-CVMCA12-20-E-G#		
	3.0 kW to 5.0 kW	3 m	JZSP-CVMCA13-03-E-G#		
		5 m	JZSP-CVMCA13-05-E-G#		
		10 m	JZSP-CVMCA13-10-E-G#		
		15 m	JZSP-CVMCA13-15-E-G#		
		20 m	JZSP-CVMCA13-20-E-G#		
For Servomotor with Holding Brakes	1.0 kW to 5.0 kW	3 m	JZSP-CVB12Y-03-E-G#		(2)
		5 m	JZSP-CVB12Y-05-E-G#		
		10 m	JZSP-CVB12Y-10-E-G#		
		15 m	JZSP-CVB12Y-15-E-G#		
		20 m	JZSP-CVB12Y-20-E-G#		

Note: The digit "#" of the order number represents the design revision.

Selecting Cables

● Servomotor Power Cable (200-V Class)

Customers must assemble the servomotor's power cables and attach connectors to connect the SERVOPACKs and the SGMSV servomotors.

The connectors for these models are round. The connectors specified by Yaskawa are required. Note that the connectors vary depending on the operation environment of servomotors.

Two types of connectors are available.

- Standard connectors
- Protective structure IP67 and European Safety Standards compliant connectors

Yaskawa does not specify which cables to use. Use appropriate cables for the connectors.

(1) Wiring Specifications for Servomotors

SERVOPACK-end Leads		Servomotor-end Connector	
Wire Color	Signal	Signal	Pin No.
Green/Yellow	FG	FG	1
Black 1	Phase W	Phase W	2
Black 2	Phase V	Phase V	3
Black 3	Phase U	Phase U	4
		-	5/6
		Shell	FG

Fix shielded cable at servopack end as shown below

Shield Wire

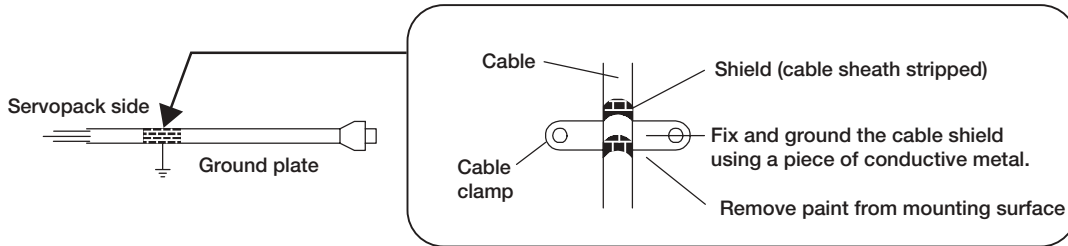

● Standard Connectors

- Connector Configuration

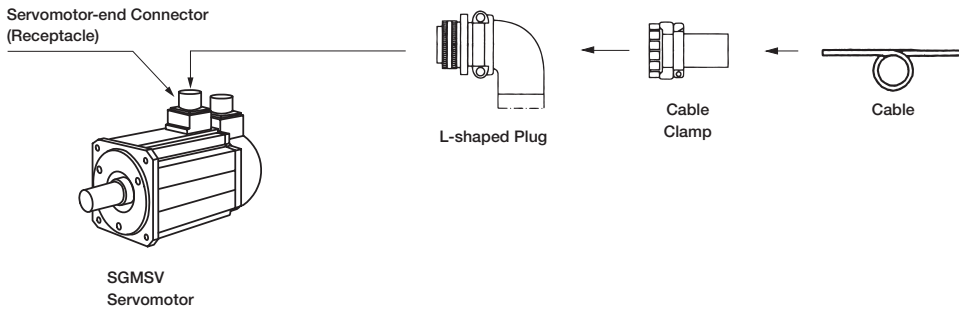

(1) Without Holding Brakes

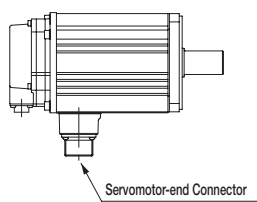

Servomotor-end Connector For 1.0 to 7.0 kW

Capacity kW	Servomotor-end Connector (Receptacle)	Cable-end Connector (Not provided by Yaskawa)	
		L-shaped Plug	Cable Clamp
1.0 to 2.5	CE05-2A18-10PD-D (MS3102A18-10P)	MS3108B18-10S	MS3057-10A
3.0 to 7.0	JL04HV-2E22-22PE-B-R (MS3102A22-22P)	MS3108B22-22S	MS3057-12A

Note: 1 Servomotor-end connectors (receptacles) are RoHS-compliant. Contact the respective connector manufacturers for RoHS-compliant cable-end connectors.
 2 Servomotor-end connectors (receptacles) can be used with MS plugs. For the model number of the MS receptacle, refer to the receptacle number in parentheses and select the appropriate plug.

Selecting Cables

(2) With Holding Brakes (200 V)

No brake connector for 200-V models
(there are brake terminals on the servomotor-end connectors).

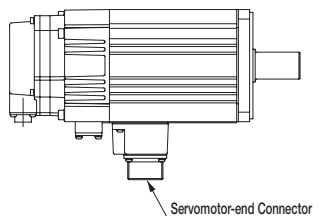

Servomotor-end Connector
For 1.0 to 5.0 kW



Capacity kW	Servomotor-end Connector (Receptacle)	Cable-end Connector (Not provided by Yaskawa)	
		L-shaped Plug	Cable Clamp
1.0 to 2.5	JL04V-2E20-15PE-B-R (MS3102A20-15P)	MS3108B20-15S	MS3057-12A
3.0 to 5.0	JL04V-2E24-10PE-B-R (MS3102A24-10P)	MS3108B24-10S	MS3057-16A

Note: 1 Servomotor-end connectors (receptacles) are RoHS-compliant. Contact the respective connector manufacturers for RoHS-compliant cable-end connectors.
2 Servomotor-end connectors (receptacles) can be used with MS plugs. For the model number of the MS receptacle, refer to the receptacle number in parentheses and select the appropriate plug.

(3) With Holding Brakes (400 V)

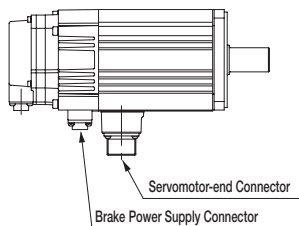

Servomotor-end Connector
For 1.0 to 5.0 kW



Capacity kW	Servomotor-end Connector (Receptacle)	Cable-end Connector (Not provided by Yaskawa)	
		L-shaped Plug	Cable Clamp
1.0 to 2.5	CE05-2A18-10PD-D (MS3102A18-10P)	MS3108B18-10S	MS3057-10A
3.0 to 5.0	JL04HV-2E22-22PE-B-R (MS3102A22-22P)	MS3108B22-22S	MS3057-12A

Note: 1 Servomotor-end connectors (receptacles) are RoHS-compliant. Contact the respective connector manufacturers for RoHS-compliant cable-end connectors.
2 Servomotor-end connectors (receptacles) can be used with MS plugs. For the model number of the MS receptacle, refer to the receptacle number in parentheses and select the appropriate plug.

Brake Power Supply Connector
For 1.0 to 5.0 kW

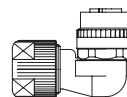

Capacity kW	Servomotor-end Connector (Receptacle)	Cable-end Connector (Not provided by Yaskawa)	
		L-shaped Plug	Manufacturer
1.0 to 5.0	CM10-R2P-D	CM10Y-AP2S-M-D-G1 Applicable Cable: 6.0 dia. to 9.0 dia.	DDK Ltd.

Selecting Cables

• Cable-end Connectors

(2) MS3108B□□-□□S : L-shaped Plug

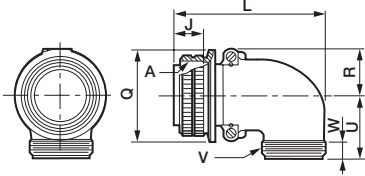

Units: mm

Shell Size	Joint Screw A	Length of Joint Portion J±0.12	Overall Length L max.	Outer Diameter of Joint Nut Q ^{+0.038} _{-0.38}	R ±0.5	U ±0.5	Cable Clamp Set Screw V	Effective Screw Length W min.
18	1-1/8-18UNEF	18.26	68.27	34.13	20.5	30.2	1-20UNEF	9.53
20	1-1/4-18UNEF	18.26	76.98	37.28	22.5	33.3	1-3/16-18UNEF	9.53
22	1-3/8-18UNEF	18.26	76.98	40.48	24.1	33.3	1-3/16-18UNEF	9.53
24	1-1/2-18UNEF	18.26	86.51	43.63	25.6	36.5	1-7/16-18UNEF	9.53

(3) MS3057-□□A : Cable Clamp with Rubber Bushing

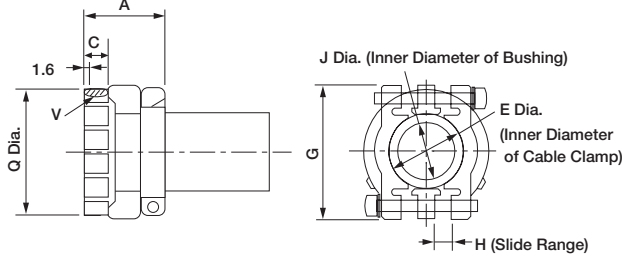

Units: mm

Cable Clamp Type	Applicable Connector Shell Size	Overall Length A±0.7	Effective Screw Length C	E Diameter	G±0.7	H	J Diameter	Set Screw V	Outer Diameter Q±0.7 Dia.	Attached Bushing
MS3057-10A	18	23.8	10.3	15.9	31.7	3.2	14.3	1-20UNEF	30.1	AN3420-10
MS3057-12A	20 22	23.8	10.3	19	37.3	4	15.9	1-3/16-18UNEF	35.0	AN3420-12
MS3057-16A	24	26.2	10.3	23.8	42.9	4.8	19.1	1-7/16-18UNEF	42.1	AN3420-16

• Dimensional Drawings of Brake Power Supply

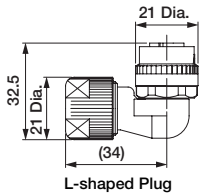

Items	Specifications
Connector Order No.	CM10- □P2S-□ -D (Cables are not included.)
Protective Structure	IP67
Manufacturer	DDK Ltd.
Instructions	L-shaped plug (CM10Y-AP2S- □ -D-G1): TC-573
Electrical Contact Order No.	Electrical contact (100 pcs in one bag) • Crimped type: CM10-#22SC(C3)(D8)-100, Wire size: AWG16 to 20, Outer diameter of sheath: 1.87 to 2.45 dia., Hand tool: 357J-50448T • Soldered type: CM10-#22SC(S2)(D8)-100, Wire size: AWG16 max. Real contact (4000 pcs on one reel) • Crimped type: CM10-#22SC(C3)(D8)-4000, Wire size: AWG 16 to 20, Outer diameter of sheath: 1.87 to 2.45 dia., Semi-automatic tool: AP-A50541T (product name for one set), AP-A50541T-1 (product name for applicator) Note: The product name of the semi-automatic tool refers to the product name of the press and applicator (crimper) as a set.

Selecting Cables

● Protective Structure IP67 and European Safety Standards Compliant Connector

● Connector Configuration

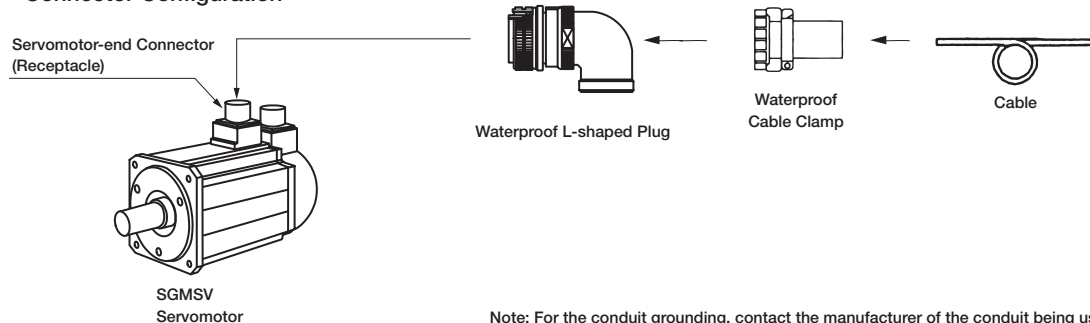

(1) Without Holding Brakes

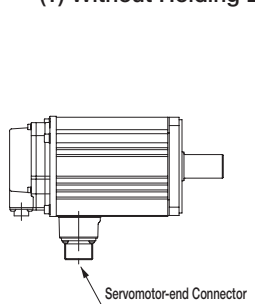

Servomotor-end Connector
For 1.0 to 7.0 kW



Capacity kW	Servomotor-end Connector (Receptacle)	Cable-end Connector (Not Provided by Yaskawa)				Manufacturer
		Plug	L-shaped Plug	Cable Clamp	Applicable Cable Diameter (For Reference)	
1.0 to 2.5	CE05-2A18-10PD-D	CE05-6A18-10SD-D	CE05-8A18-10SD-D-BAS	CE3057-10A-1-D	10.5 dia. to 14.1 dia.	DDK Ltd.
				CE3057-10A-2-D	8.5 dia. to 11.0 dia.	
				CE3057-10A-3-D	6.5 dia. to 8.7 dia.	
3.0 to 7.0	JL04HV-2E22-22PE-B-R	JL04V-6A22-22SE-R	JL04V-8A22-22SE-EB-R or JA08A-22-22S-J1-EB-R*	JL04-2022CK (09) -R	6.5 Dia. to 9.5 Dia.	Japan Aviation Electronics Industry, Ltd.
				JL04-2022CK (12) -R	9.5 Dia. to 13.0 Dia.	
				JL04-2022CK (14) -R	12.9 Dia. to 15.9 Dia.	

*: Not compliant with European Safety Standards, but compliant with protective structure IP67.

(2) With Holding Brakes (200 V)

No brake connector for 200-V models (there are brake terminals on the servomotor-end connectors).

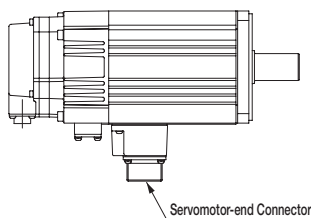

Servomotor-end Connector
For 1.0 to 5.0 kW

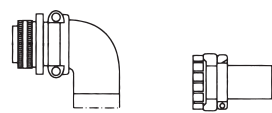

Capacity kW	Servomotor-end Connector (Receptacle)	Cable-end Connector (Not Provided by Yaskawa)				Manufacturer
		Plug	L-shaped Plug	Cable Clamp	Applicable Cable Diameter (For Reference)	
1.0 to 2.5	JL04V-2E20-15PE-B-R	JL04V-6A20-15SE-R	JL04V-8A20-15SE-EB-R	JL04-2022CK (09) -R	6.5 Dia. to 9.5 Dia.	Japan Aviation Electronics Industry, Ltd.
				JL04-2022CK (12) -R	9.5 Dia. to 13.0 Dia.	
				JL04-2022CK (14) -R	12.9 Dia. to 15.9 Dia.	
3.0 to 5.0	JL04V-2E24-10PE-B-R	JL04V-6A24-10SE-R	JL04V-8A24-10SE-EB-R or JA08A-24-10S-J1-EB-R*	JL04-2428CK (11) -R	9.0 Dia. to 12.0 Dia.	Japan Aviation Electronics Industry, Ltd.
				JL04-2428CK (14) -R	12.0 Dia. to 15.0 Dia.	
				JL04-2428CK (17) -R	15.0 Dia. to 18.0 Dia.	
				JL04-2428CK (20) -R	18.0 Dia. to 20.0 Dia.	

*: Not compliant with European Safety Standards, but compliant with protective structure IP67.

Selecting Cables

(3) With Holding Brakes (400 V)

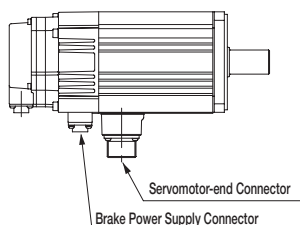

Servomotor-end Connector
For 1.0 to 5.0 kW



Capacity kW	Servomotor-end Connector (Receptacle)	Cable-end Connector (Not Provided by Yaskawa)				
		Plug	L-shaped Plug	Cable Clamp	Applicable Cable Diameter (For Reference)	Manufacturer
1.0 to 2.5	CE05-2A18-10PD-D	CE05-6A18-10SD-D	CE05-8A18-10SD-D-BAS	CE3057-10A-1-D	10.5 dia. to 14.1 dia.	DDK Ltd.
				CE3057-10A-2-D	8.5 dia. to 11.0 dia.	
				CE3057-10A-3-D	6.5 dia. to 8.7 dia.	
3.0 to 5.0	JL04HV-2E22-22PE-B-R	JL04V-6A22-22SE-R	JL04V-8A22-22SE-EB-R or JA08A-22-22S-J1-EB-R*	JL04-2022CK(09)-R	6.5 Dia. to 9.5 Dia.	Japan Aviation Electronics Industry, Ltd.
				JL04-2022CK(12)-R	9.5 Dia. to 13.0 Dia.	
				JL04-2022CK(14)-R	12.9 Dia. to 15.9 Dia.	

*: Not compliant with European Safety Standards, but compliant with protective structure IP67.

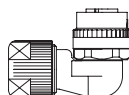

Brake Power Supply Connector
For 1.0 to 5.0 kW



Capacity kW	Servomotor-end Connector (Receptacle)	Cable-end Connector (Not provided by Yaskawa)	
		L-shaped Plug	Manufacturer
1.0 to 5.0	CM10-R2P-D	CM10Y-AP2S-M-D-G1 Applicable Cable: 6.0 dia. to 9.0 dia.	DDK Ltd.

Selecting Cables

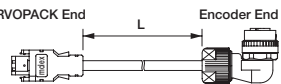
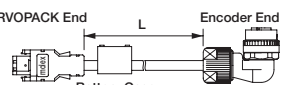
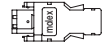
● Encoder Cables (Max. length: 20 m)

Name	Length (L)	Order No.	Specifications	Details
		Flexible Type		
Encoder Cable with Connectors (For Incremental Encoder)	3 m	JZSP-CVP12-03-E-G#	 <p>SERVOPACK End L Encoder End</p> <p>Connector (Crimped) (Molex Japan Co., Ltd.) CM10-AP10S-□-D (DDK Ltd.)</p>	(1)
	5 m	JZSP-CVP12-05-E-G#		
	10 m	JZSP-CVP12-10-E-G#		
	15 m	JZSP-CVP12-15-E-G#		
	20 m	JZSP-CVP12-20-E-G#		
Encoder Cable with Connectors (For Absolute Encoder, with a Battery Case)	3 m	JZSP-CVP27-03-E-G#	 <p>SERVOPACK End L Encoder End</p> <p>Connector (Crimped)(Molex Japan Co., Ltd.) Battery Case (Battery Attached) CM10-AP10S-□-D (DDK Ltd.)</p>	(2)
	5 m	JZSP-CVP27-05-E-G#		
	10 m	JZSP-CVP27-10-E-G#		
	15 m	JZSP-CVP27-15-E-G#		
	20 m	JZSP-CVP27-20-E-G#		
SERVOPACK-end Connector Kit		JZSP-CMP9-1-E	<p>Soldered</p>  <p>(Molex Japan Co., Ltd.)</p>	(3)
Encoder-end Connectors for Protective Structure IP67 L-shaped Plug		CM10-AP10S-M-D-G1 (Connector Kit including contacts)	 <p>(DDK Ltd.)</p>	-

Note: The digit "#" of the order number represents the design revision.

Selecting Cables

(1) Wiring Specifications for Cable with Connectors
(For incremental encoder)

• Flexible Type

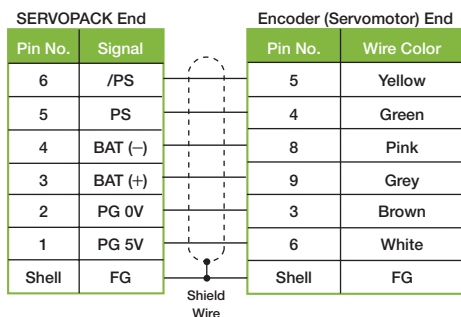

(2) Wiring Specifications for Cable with Connectors
(For absolute encoder, with a battery case)

• Flexible Type

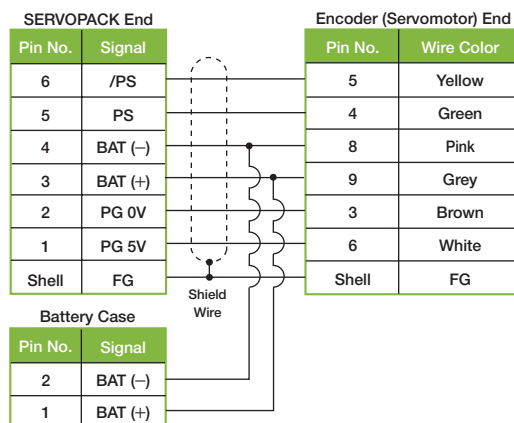

(3) SERVOPACK-end Connector Kit Specifications

Items	Specifications
Order No.	JZSP-CMP9-1-E
Manufacturer	Molex Japan Co., Ltd.
Connector Model (For standard)	55100-0670 (soldered)
External Dimensions (Units: mm)	

(4) Cable Specifications

Items	Flexible Type
Cable Length	20 m max.
Specifications	UL20276 (Rating temperature: 80°C) AWG22×2C + AWG24×2P AWG22 (0.33 mm ²) Outer diameter of insulating sheath: 1.35 dia. AWG24 (0.20 mm ²) Outer diameter of insulating sheath: 1.21 dia.
Finished Dimensions	6.8 dia.
Internal Configuration and Lead Color	

Selecting Cables

Encoder Cables (For extending from 30 to 50 m)

Name	Length	Order No.	Specifications	Details
① Encoder-end Cables (For incremental and absolute encoder)	0.3 m	JZSP-CVP01-E		(1)
		JZSP-CVP02-E		
② Cable with Connectors (For incremental and absolute encoder)	30 m	JZSP-UCMP00-30-E		(2)
	40 m	JZSP-UCMP00-40-E		
	50 m	JZSP-UCMP00-50-E		
③ Cable with a Battery Case (For absolute encoder*)	0.3 m	JZSP-CSP12-E		(3)
④ Relay Cables	30 m	JZSP-CMP19-30-E		(4)
	40 m	JZSP-CMP19-40-E		
	50 m	JZSP-CMP19-50-E		

*: Not required when connecting a battery to the host controller.

(1) Wiring Specifications for Encoder-end Cable (For incremental and absolute encoder)

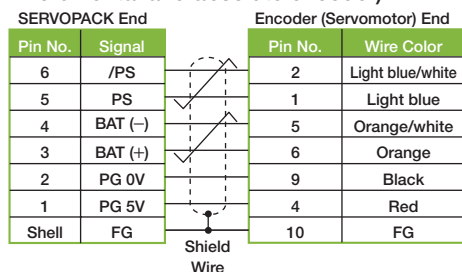

Note: The signals BAT(+) and BAT(-) are used when using an absolute encoder.

(3) Wiring Specifications for Cable with a Battery Case (For absolute encoder)

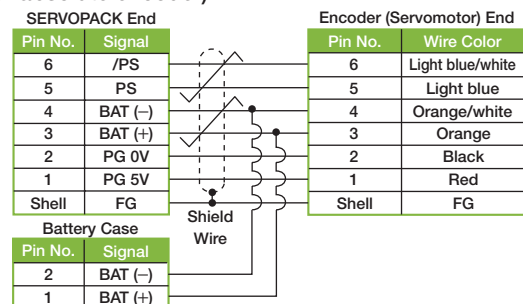

(2) Wiring Specifications for Cable with Connectors (For incremental and absolute encoder)

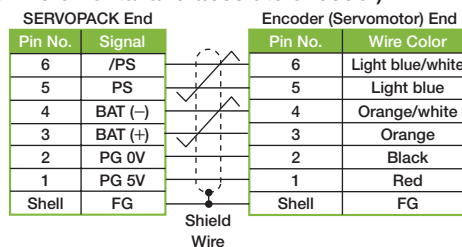

(4) Relay Encoder Cable Specifications

Item	Standard Type
Order No.*	JZSP-CMP19-□□-E
Cable Length	50 m max.
Specifications	UL20276 (Rating temperature: 80°C) AWG16×2C+AWG26×2P AWG16 (1.31 mm ²) Outer diameter of insulating sheath: 2.0 dia. mm AWG26 (0.13 mm ²) Outer diameter of insulating sheath: 0.91 dia. mm
Finished Dimensions	6.8 dia.
Internal Configuration and Lead Colors	
Yaskawa Standard Specifications (Standard Length)	Cable length: 30 m, 40 m, 50 m

*: Specify the cable length in □□ of order no.
Example: JZSP-CMP19-30-E (30 m)