

VIPA System 300S

SM-DIO | | Manual

HB140 | SM-DIO | | en | Rev. 16-43

Digital signal modules - SM 32x(S)



VIPA GmbH
Ohmstr. 4
91074 Herzogenaurach
Telephone: 09132-744-0
Fax: 09132-744-1864
Email: info@vipa.com
Internet: www.vipa.com

Table of contents

1	Basics	5
1.1	Copyright © VIPA GmbH	5
1.2	About this manual.....	6
1.3	Safety information.....	7
2	Assembly and installation guidelines	8
2.1	Safety information for users.....	8
2.2	Overview.....	9
2.3	Installation dimensions.....	9
2.4	Assembly SPEED-Bus.....	11
2.5	Assembly standard bus.....	14
2.6	Cabling.....	16
2.7	Installation guidelines.....	19
2.8	General data I/O modules.....	21
2.8.1	General data.....	22
3	Digital Input Modules	24
3.1	321-1BH01 - DI 16xDC 24V.....	24
3.1.1	Technical data.....	25
3.2	321-1BL00 - DI 32xDC 24V.....	27
3.2.1	Technical data.....	29
3.3	321-1FH00 - DI 16xAC 120/230V.....	31
3.3.1	Technical data.....	33
4	Digital Output Modules	35
4.1	Safe shutdown of non-safe outputs.....	35
4.1.1	Introduction.....	35
4.1.2	Safe shutdown.....	35
4.1.3	Requirements and fault exclusions.....	36
4.2	322-1BF01 - DO 8xDC 24V 2A.....	38
4.2.1	Technical data.....	39
4.3	322-1BH01 - DO 16xDC 24V 1A.....	41
4.3.1	Technical data.....	43
4.4	322-1BH41 - DO 16xDC 24V 2A.....	45
4.4.1	Technical data.....	48
4.5	322-1BH60 - DO 16xDC 24V 0.5A for manual operation.....	50
4.5.1	Deployment.....	52
4.5.2	Technical data.....	52
4.6	322-1BL00 - DO 32xDC 24V 1A	54
4.6.1	Deployment.....	57
4.6.2	Technical data.....	57
4.7	322-5FF00 - DO 8xAC 120/230V 2A	59
4.7.1	Parameterization	62
4.7.2	Technical data.....	63
4.8	322-1HH00 - DO 16xRelay	65
4.8.1	Technical data.....	68
5	Digital Input/Output Modules	71
5.1	323-1BH00 - DIO 16xDC 24V 1A.....	71
5.1.1	Technical data.....	73
5.2	323-1BH01 - DI 8xDC 24V, DO 8xDC 24V 1A.....	75

5.2.1	Technical data.....	77
5.3	323-1BL00 - DI 16xDC 24V, DO 16xDC 24V 1A.....	80
5.3.1	Technical data.....	82
6	Digital Modules FAST - SPEED-Bus.....	85
6.1	Addressing at SPEED-Bus.....	85
6.2	Project engineering.....	85
6.2.1	Fast introduction.....	86
6.2.2	Preconditions.....	86
6.2.3	Steps of project engineering.....	87
6.3	321-1BH70 - DI 16xDC 24V.....	89
6.3.1	Parameterization.....	92
6.3.2	Process interrupt.....	96
6.3.3	Diagnostic interrupt.....	97
6.3.4	Technical data.....	100
6.4	322-1BH70 - DO 16xDC 24V 0.5A.....	102
6.4.1	Technical data.....	105
6.5	323-1BH70 - DIO 16xDC 24V 0.5A.....	106
6.5.1	Parameterization.....	109
6.5.2	Process interrupt.....	114
6.5.3	Diagnostic interrupt.....	114
6.5.4	Technical data.....	117

1 Basics

1.1 Copyright © VIPA GmbH

All Rights Reserved

This document contains proprietary information of VIPA and is not to be disclosed or used except in accordance with applicable agreements.

This material is protected by the copyright laws. It may not be reproduced, distributed, or altered in any fashion by any entity (either internal or external to VIPA), except in accordance with applicable agreements, contracts or licensing, without the express written consent of VIPA and the business management owner of the material.

For permission to reproduce or distribute, please contact: VIPA, Gesellschaft für Visualisierung und Prozessautomatisierung mbH Ohmstraße 4, D-91074 Herzogenaurach, Germany

Tel.: +49 9132 744 -0

Fax.: +49 9132 744-1864

E-Mail: info@vipa.de

<http://www.vipa.com>



Every effort has been made to ensure that the information contained in this document was complete and accurate at the time of publishing. Nevertheless, the authors retain the right to modify the information.

This customer document describes all the hardware units and functions known at the present time. Descriptions may be included for units which are not present at the customer site. The exact scope of delivery is described in the respective purchase contract.

CE Conformity Declaration

Hereby, VIPA GmbH declares that the products and systems are in compliance with the essential requirements and other relevant provisions. Conformity is indicated by the CE marking affixed to the product.

Conformity Information

For more information regarding CE marking and Declaration of Conformity (DoC), please contact your local VIPA customer service organization.

Trademarks

VIPA, SLIO, System 100V, System 200V, System 300V, System 300S, System 400V, System 500S and Commander Compact are registered trademarks of VIPA Gesellschaft für Visualisierung und Prozessautomatisierung mbH.

SPEED7 is a registered trademark of profichip GmbH.

SIMATIC, STEP, SINEC, TIA Portal, S7-300 and S7-400 are registered trademarks of Siemens AG.

Microsoft and Windows are registered trademarks of Microsoft Inc., USA.

Portable Document Format (PDF) and Postscript are registered trademarks of Adobe Systems, Inc.

All other trademarks, logos and service or product marks specified herein are owned by their respective companies.

Information product support

Contact your local VIPA Customer Service Organization representative if you wish to report errors or questions regarding the contents of this document. If you are unable to locate a customer service centre, contact VIPA as follows:

VIPA GmbH, Ohmstraße 4, 91074 Herzogenaurach, Germany
Telefax: +49 9132 744-1204
EMail: documentation@vipa.de

Technical support

Contact your local VIPA Customer Service Organization representative if you encounter problems with the product or have questions regarding the product. If you are unable to locate a customer service centre, contact VIPA as follows:

VIPA GmbH, Ohmstraße 4, 91074 Herzogenaurach, Germany
Tel.: +49 9132 744-1150 (Hotline)
EMail: support@vipa.de

1.2 About this manual

Target audience

The manual is targeted at users who have a background in automation technology.

Structure of the manual

The manual consists of chapters. Every chapter provides a self-contained description of a specific topic.

Guide to the document

The following guides are available in the manual:

- An overall table of contents at the beginning of the manual
- References with page numbers

Availability

The manual is available in:

- printed form, on paper
- in electronic form as PDF-file (Adobe Acrobat Reader)

Icons Headings

Important passages in the text are highlighted by following icons and headings:

**DANGER!**

Immediate or likely danger. Personal injury is possible.

**CAUTION!**

Damages to property is likely if these warnings are not heeded.



Supplementary information and useful tips.

1.3 Safety information

Applications conforming with specifications

The system is constructed and produced for:

- communication and process control
- general control and automation tasks
- industrial applications
- operation within the environmental conditions specified in the technical data
- installation into a cubicle



DANGER!

This device is not certified for applications in

- in explosive environments (EX-zone)

Documentation

The manual must be available to all personnel in the

- project design department
- installation department
- commissioning
- operation



CAUTION!

The following conditions must be met before using or commissioning the components described in this manual:

- Hardware modifications to the process control system should only be carried out when the system has been disconnected from power!
- Installation and hardware modifications only by properly trained personnel.
- The national rules and regulations of the respective country must be satisfied (installation, safety, EMC ...)

Disposal

National rules and regulations apply to the disposal of the unit!

2 Assembly and installation guidelines

2.1 Safety information for users

Handling of electrostatic sensitive modules

VIPA modules make use of highly integrated components in MOS-Technology. These components are extremely sensitive to over-voltages that can occur during electrostatic discharges. The following symbol is attached to modules that can be destroyed by electrostatic discharges.



The Symbol is located on the module, the module rack or on packing material and it indicates the presence of electrostatic sensitive equipment. It is possible that electrostatic sensitive equipment is destroyed by energies and voltages that are far less than the human threshold of perception. These voltages can occur where persons do not discharge themselves before handling electrostatic sensitive modules and they can damage components thereby, causing the module to become inoperable or unusable. Modules that have been damaged by electrostatic discharges can fail after a temperature change, mechanical shock or changes in the electrical load. Only the consequent implementation of protection devices and meticulous attention to the applicable rules and regulations for handling the respective equipment can prevent failures of electrostatic sensitive modules.

Shipping of modules

Modules must be shipped in the original packing material.

Measurements and alterations on electrostatic sensitive modules

When you are conducting measurements on electrostatic sensitive modules you should take the following precautions:

- Floating instruments must be discharged before use.
- Instruments must be grounded.

Modifying electrostatic sensitive modules you should only use soldering irons with grounded tips.



CAUTION!

Personnel and instruments should be grounded when working on electrostatic sensitive modules.

2.2 Overview

General

While the standard peripheral modules are plugged-in at the right side of the CPU, the SPEED-Bus peripheral modules are connected via a SPEED-Bus bus connector at the left side of the CPU. VIPA delivers profile rails with integrated SPEED-Bus for 2, 6 or 10 SPEED-Bus peripheral modules with different lengths.

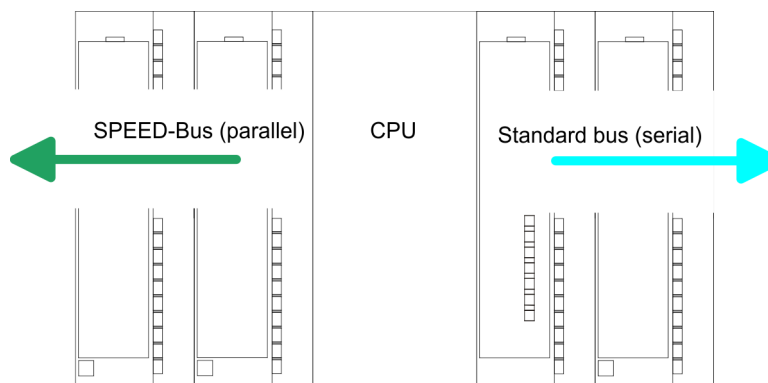

Serial Standard bus

The single modules are directly installed on a profile rail and connected via the backplane bus coupler. Before installing the modules you have to clip the backplane bus coupler to the module from the backside. The backplane bus couplers are included in the delivery of the peripheral modules.

Parallel SPEED-Bus

With SPEED-Bus the bus connection happens via a SPEED-Bus rail integrated in the profile rail at the left side of the CPU. Due to the parallel SPEED-Bus not all slots must be occupied in sequence.

SLOT 1 for additional power supply

At slot (SLOT 1 DCDC) you may plug either a SPEED-Bus module or an additional power supply.

Assembly possibilities

You may assemble the System 300 horizontally, vertically or lying.

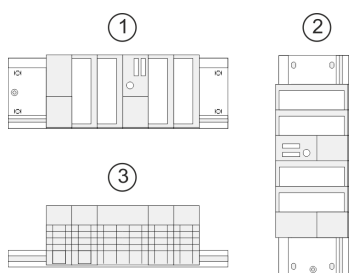

Please regard the allowed environment temperatures:

- horizontal assembly: from 0 to 60°C
- vertical assembly: from 0 to 40°C
- lying assembly: from 0 to 40°C

2.3 Installation dimensions

Dimensions Basic enclosure

1tier width (WxHxD) in mm: 40 x 125 x 120

Dimensions

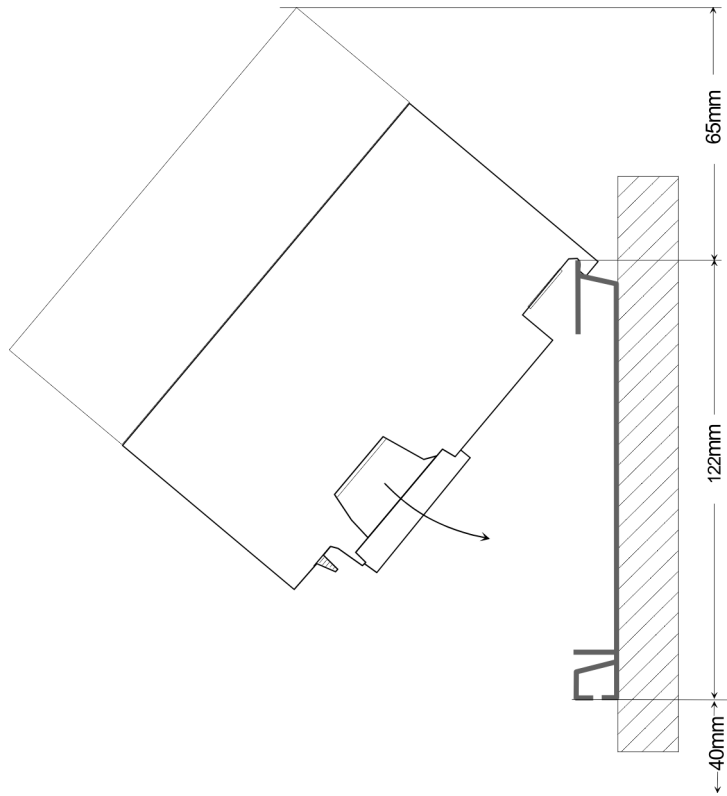

Installation dimensions

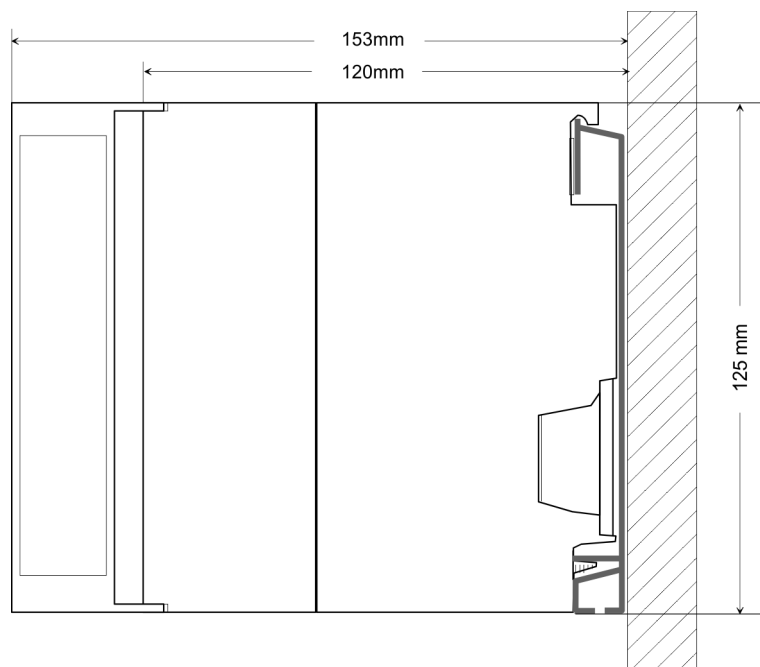

2.4 Assembly SPEED-Bus

Pre-manufactured SPEED-Bus profile rail

For the deployment of SPEED-Bus modules, a pre-manufactured SPEED-Bus rail is required. This is available mounted on a profile rail with 2, 6 or 10 extension slots.

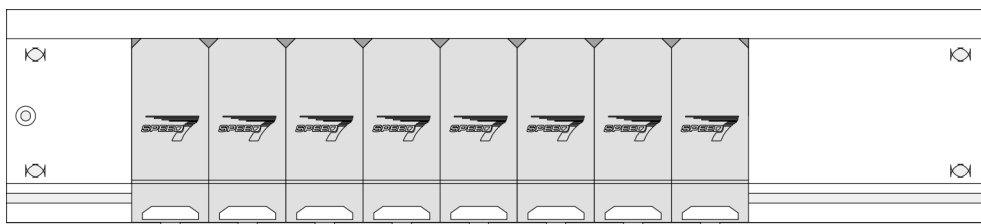

Dimensions

Order number	Number of modules SPEED-Bus/Standard bus	A	B	C	D	E
391-1AF10	2/6	530	100	268	510	10
391-1AF30	6/2	530	100	105	510	10
391-1AF50	10/0	530	20	20	510	10
391-1AJ10	2/15	830	22	645	800	15
391-1AJ30	6/11	830	22	480	800	15
391-1AJ50	10/7	830	22	320	800	15

Measures in mm

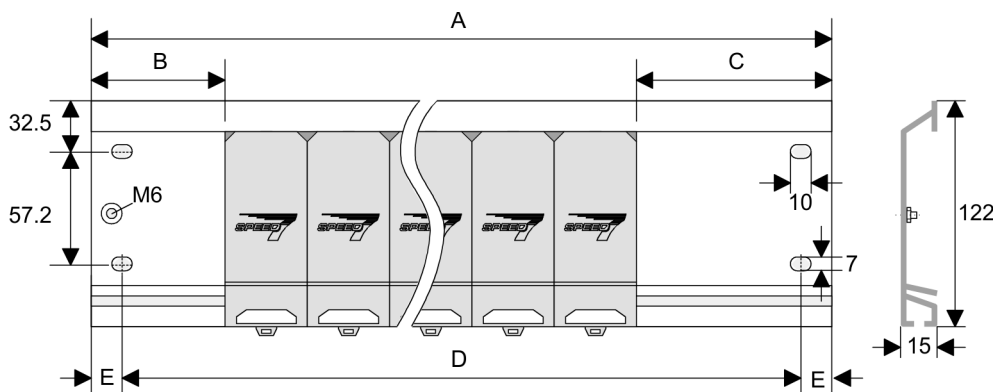

Installation of the profile rail

1. Bolt the profile rail with the background (screw size: M6), so that you still have minimum 65mm space above and 40mm below the profile rail. Please look for a low-impedance connection between profile rail and background.

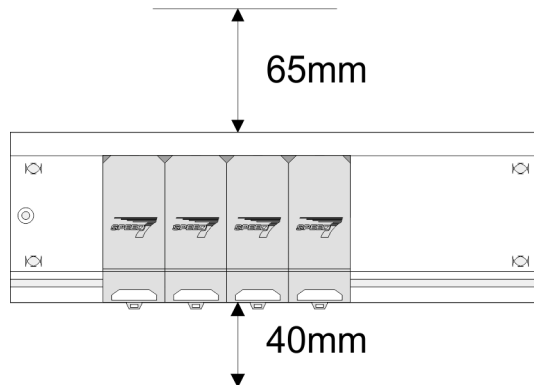

2. Connect the profile rail with the protected earth conductor. The minimum cross-section of the cable to the protected earth conductor has to be 10mm².

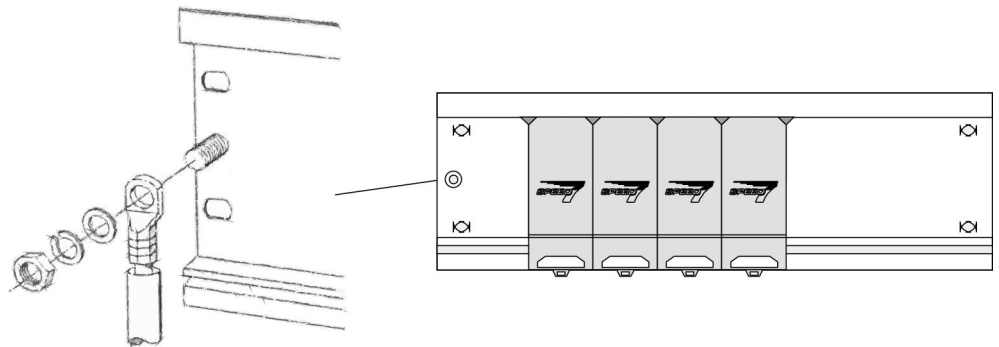

Installation SPEED-Bus module

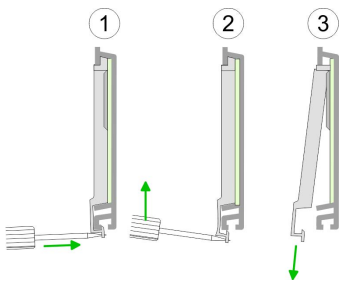

1. Dismantle the according protection flaps of the SPEED-Bus slot with a screw driver (open and pull down).

For the SPEED-Bus is a parallel bus, not every SPEED-Bus slot must be used in series. Leave the protection flap installed at an unused SPEED-Bus slot.

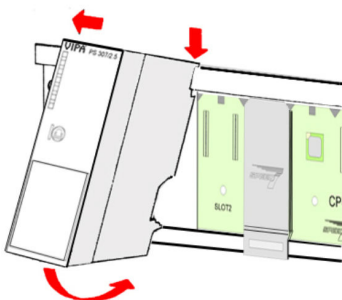

2. At deployment of a DC 24V power supply, install it at the shown position at the profile rail at the left side of the SPEED-Bus and push it to the left to the isolation bolt of the profile rail.
3. Fix the power supply by screwing.

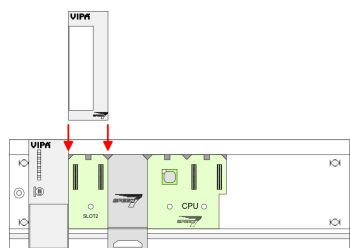

4. ➤ To connect the SPEED-Bus modules, plug it between the triangular positioning helps to a slot marked with "SLOT ..." and pull it down.
5. ➤ Only the "SLOT1 DCDC" allows you to plug-in either a SPEED-Bus module or an additional power supply.
6. ➤ Fix the CPU by screwing.

Installation CPU without Standard-Bus-Modules

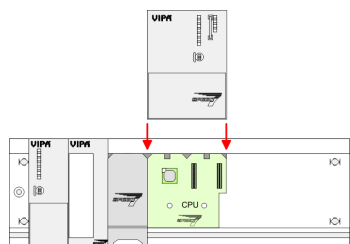

1. ➤ To deploy the SPEED7-CPU exclusively at the SPEED-Bus, plug it between the triangular positioning helps to the slot marked with "CPU SPEED7" and pull it down.

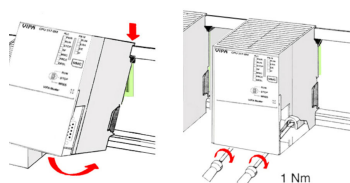

2. ➤ Fix the CPU by screwing.

Installation CPU with Standard-Bus-Modules

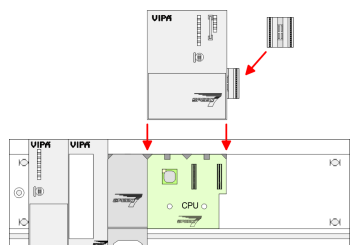

1. ➤ If also standard modules shall be plugged, take a bus coupler and click it at the CPU from behind like shown in the picture. Plug the CPU between the triangular positioning helps to the slot marked with "CPU SPEED7" and pull it down.

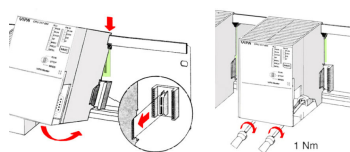

2. ➤ Plug the CPU between the triangular positioning helps to the plug-in location marked with "CPU SPEED7" and pull it down. Fix the CPU by screwing.

Installation Standard-Bus-Modules

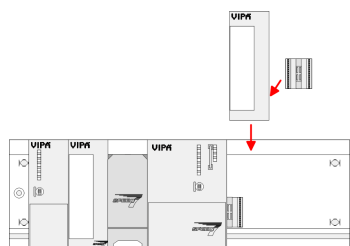

- Repeat this procedure with the peripheral modules, by clicking a backplane bus coupler, stick the module right from the modules you've already fixed, click it downwards and connect it with the backplane bus coupler of the last module and bolt it.



CAUTION!

- The power supplies must be released before installation and repair tasks, i.e. before handling with the power supply or with the cabling you must disconnect current/voltage (pull plug, at fixed connection switch off the concerning fuse)!
- Installation and modifications only by properly trained personnel!

2.5 Assembly standard bus

General

The single modules are directly installed on a profile rail and connected via the backplane bus connector. Before installing the modules you have to clip the backplane bus connector to the module from the backside. The backplane bus connector is delivered together with the peripheral modules.

Profile rail

Order number	A	B	C
390-1AB60	160	140	10
390-1AE80	482	466	8.3
390-1AF30	530	500	15
390-1AJ30	830	800	15
390-9BC00*	2000	Drillings only left	15

*) Unit pack: 10 pieces

Measures in mm

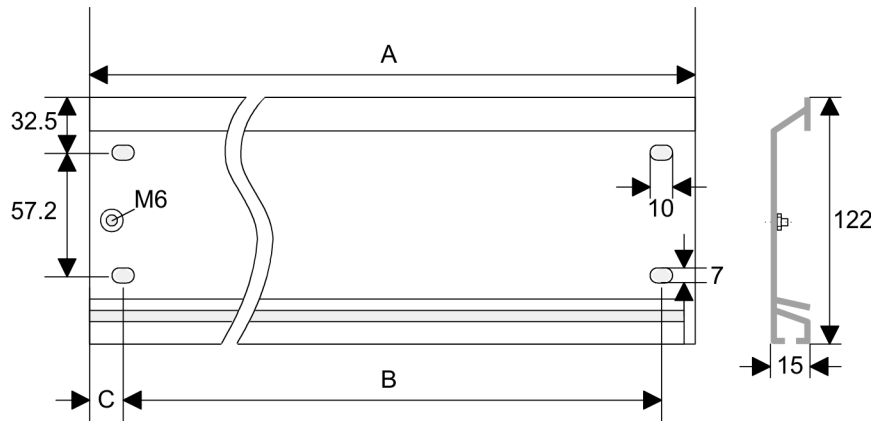

Bus connector

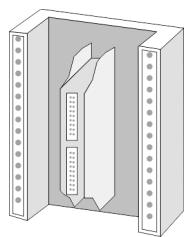

For the communication between the modules the System 300S uses a backplane bus connector. Backplane bus connectors are included in the delivering of the peripheral modules and are clipped at the module from the backside before installing it to the profile rail.

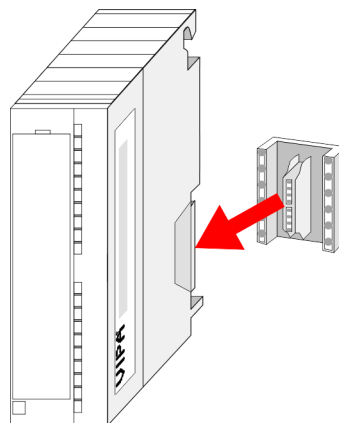

Assembly possibilities

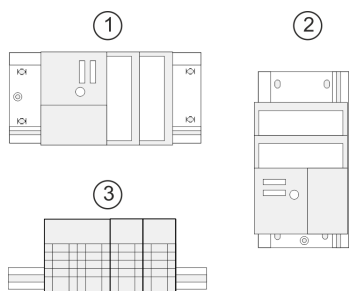

Please regard the allowed environment temperatures:

- horizontal assembly: from 0 to 60°C
- vertical assembly: from 0 to 50°C
- lying assembly: from 0 to 55°C

Approach

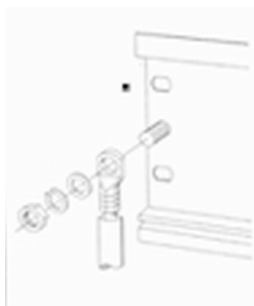

If you do not deploy SPEED-Bus modules, the assembly happens with the following approach:

1. Bolt the profile rail with the background (screw size: M6), so that you still have minimum 65mm space above and 40mm below the profile rail.
2. If the background is a grounded metal or device plate, please look for a low-impedance connection between profile rail and background.
3. Connect the profile rail with the protected earth conductor. For this purpose there is a bolt with M6-thread.
4. The minimum cross-section of the cable to the protected earth conductor has to be 10mm².
5. Stick the power supply to the profile rail and pull it to the left side to the grounding bolt of the profile rail.
6. Fix the power supply by screwing.
7. Take a backplane bus connector and click it at the CPU from the backside like shown in the picture.
8. Stick the CPU to the profile rail right from the power supply and pull it to the power supply.

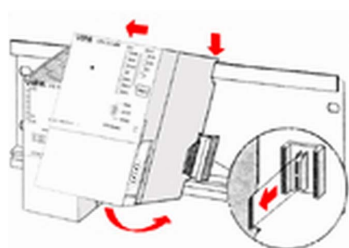

Cabling

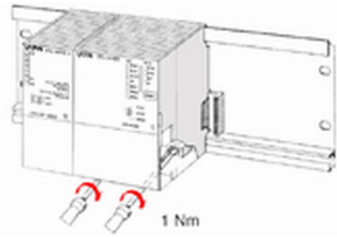

9. Click the CPU downwards and bolt it like shown.
10. Repeat this procedure with the peripheral modules, by clicking a backplane bus connector, stick the module right from the modules you've already fixed, click it downwards and connect it with the backplane bus connector of the last module and bolt it.

2.6 Cabling



CAUTION!

- The power supplies must be released before installation and repair tasks, i.e. before handling with the power supply or with the cabling you must disconnect current/voltage (pull plug, at fixed connection switch off the concerning fuse)!
- Installation and modifications only by properly trained personnel!

CageClamp technology (green)

For the cabling of power supply of a CPU, a green plug with CageClamp technology is deployed. The connection clamp is realized as plug that may be clipped off carefully if it is still cabled.

Here wires with a cross-section of 0.08mm^2 to 2.5mm^2 may be connected. You can use flexible wires without end case as well as stiff wires.

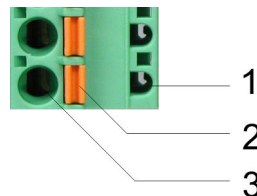

- 1 Test point for 2mm test tip
- 2 Locking (orange) for screwdriver
- 3 Round opening for wires

The picture on the left side shows the cabling step by step from top view.

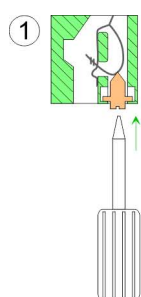

1. ➤ For cabling you push the locking vertical to the inside with a suitable screwdriver and hold the screwdriver in this position.

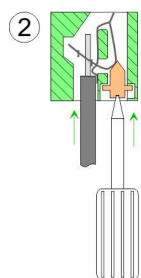

2. ➤ Insert the de-isolated wire into the round opening. You may use wires with a cross-section from 0.08mm^2 to 2.5mm^2

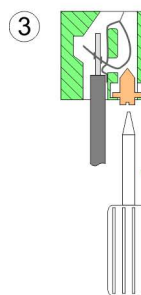

3. ➤ By removing the screwdriver the wire is connected safely with the plug connector via a spring.

Front connectors of the in-/output modules

In the following the cabling of the two variants are shown.

**20pole screw connection
392-1AJ00**



1. ➤ Open the front flap of your I/O module.
2. ➤ Bring the front connector in cabling position.
For this you plug the front connector on the module until it locks. In this position the front connector juts out of the module and has no contact yet.
3. ➤ De-isolate your wires. If needed, use core end cases.
4. ➤ Thread the included cable binder into the front connector.
5. ➤ If you want to lead out your cables from the bottom of the module, start with the cabling from bottom to top, res. from top to bottom, if the cables should be led out at the top.
6. ➤ Bolt also the connection screws of not cabled screw clamps.

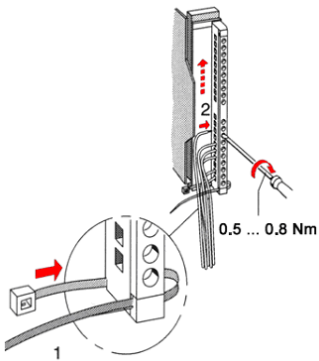

7. ➤ Fix the cable binder for the cable bundle.

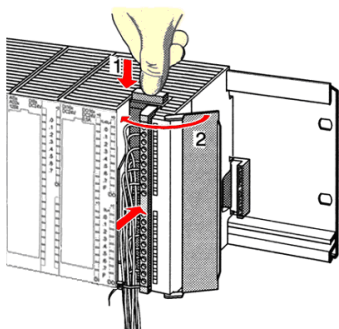

8. ➤ Push the release key at the front connector on the upper side of the module and at the same time push the front connector into the module until it locks.
9. ➤ Now the front connector is electrically connected with your module.
10. ➤ Close the front flap.
11. ➤ Fill out the labeling strip to mark the single channels and push the strip into the front flap.

40pole screw connection 392-1AM00



1. ➤ Open the front flap of your I/O module.
2. ➤ Bring the front connector in cabling position.
For this you plug the front connector on the module until it locks. In this position the front connector juts out of the module and has no contact yet.
3. ➤ De-isolate your wires. If needed, use core end cases.
4. ➤ If you want to lead out your cables from the bottom of the module, start with the cabling from bottom to top, res. from top to bottom, if the cables should be led out at the top.
5. ➤ Bolt also the connection screws of not cabled screw clamps.

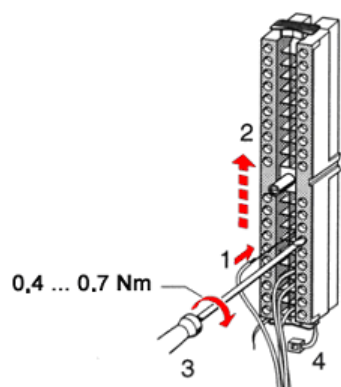

6. ➤ Put the included cable binder around the cable bundle and the front connector.
7. ➤ Fix the cable binder for the cable bundle.

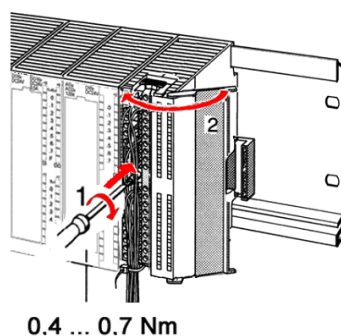

8. ➤ Bolt the fixing screw of the front connector.
9. ➤ Now the front connector is electrically connected with your module.
10. ➤ Close the front flap.
11. ➤ Fill out the labeling strip to mark the single channels and push the strip into the front flap.

2.7 Installation guidelines

General

The installation guidelines contain information about the interference free deployment of a PLC system. There is the description of the ways, interference may occur in your PLC, how you can make sure the electromagnetic compatibility (EMC), and how you manage the isolation.

What does EMC mean?

Electromagnetic compatibility (EMC) means the ability of an electrical device, to function error free in an electromagnetic environment without being interfered respectively without interfering the environment.

The components of VIPA are developed for the deployment in industrial environments and meets high demands on the EMC. Nevertheless you should project an EMC planning before installing the components and take conceivable interference causes into account.

Possible interference causes

Electromagnetic interferences may interfere your control via different ways:

- Electromagnetic fields (RF coupling)
- Magnetic fields with power frequency
- Bus system
- Power supply
- Protected earth conductor

Depending on the spreading medium (lead bound or lead free) and the distance to the interference cause, interferences to your control occur by means of different coupling mechanisms.

There are:

- galvanic coupling
- capacitive coupling
- inductive coupling
- radiant coupling

Basic rules for EMC

In the most times it is enough to take care of some elementary rules to guarantee the EMC. Please regard the following basic rules when installing your PLC.

- Take care of a correct area-wide grounding of the inactive metal parts when installing your components.
 - Install a central connection between the ground and the protected earth conductor system.
 - Connect all inactive metal extensive and impedance-low.
 - Please try not to use aluminium parts. Aluminium is easily oxidizing and is therefore less suitable for grounding.
- When cabling, take care of the correct line routing.
 - Organize your cabling in line groups (high voltage, current supply, signal and data lines).
 - Always lay your high voltage lines and signal respectively data lines in separate channels or bundles.
 - Route the signal and data lines as near as possible beside ground areas (e.g. suspension bars, metal rails, tin cabinet).
- Proof the correct fixing of the lead isolation.
 - Data lines must be laid isolated.
 - Analog lines must be laid isolated. When transmitting signals with small amplitudes the one sided laying of the isolation may be favourable.
 - Lay the line isolation extensively on an isolation/protected earth conductor rail directly after the cabinet entry and fix the isolation with cable clamps.
 - Make sure that the isolation/protected earth conductor rail is connected impedance-low with the cabinet.
 - Use metallic or metallised plug cases for isolated data lines.

- In special use cases you should appoint special EMC actions.
 - Consider to wire all inductivities with erase links.
 - Please consider luminescent lamps can influence signal lines.
- Create a homogeneous reference potential and ground all electrical operating supplies when possible.
 - Please take care for the targeted employment of the grounding actions. The grounding of the PLC serves for protection and functionality activity.
 - Connect installation parts and cabinets with your PLC in star topology with the isolation/protected earth conductor system. So you avoid ground loops.
 - If there are potential differences between installation parts and cabinets, lay sufficiently dimensioned potential compensation lines.

Isolation of conductors

Electrical, magnetically and electromagnetic interference fields are weakened by means of an isolation, one talks of absorption. Via the isolation rail, that is connected conductive with the rack, interference currents are shunt via cable isolation to the ground. Here you have to make sure, that the connection to the protected earth conductor is impedance-low, because otherwise the interference currents may appear as interference cause.

When isolating cables you have to regard the following:

- If possible, use only cables with isolation tangle.
- The hiding power of the isolation should be higher than 80%.
- Normally you should always lay the isolation of cables on both sides. Only by means of the both-sided connection of the isolation you achieve high quality interference suppression in the higher frequency area. Only as exception you may also lay the isolation one-sided. Then you only achieve the absorption of the lower frequencies. A one-sided isolation connection may be convenient, if:
 - the conduction of a potential compensating line is not possible.
 - analog signals (some mV respectively μA) are transferred.
 - foil isolations (static isolations) are used.
- With data lines always use metallic or metallised plugs for serial couplings. Fix the isolation of the data line at the plug rack. Do not lay the isolation on the PIN 1 of the plug bar!
- At stationary operation it is convenient to strip the insulated cable interruption free and lay it on the isolation/protected earth conductor line.
- To fix the isolation tangles use cable clamps out of metal. The clamps must clasp the isolation extensively and have well contact.
- Lay the isolation on an isolation rail directly after the entry of the cable in the cabinet. Lead the isolation further on to your PLC and don't lay it on there again!



CAUTION!

Please regard at installation!

At potential differences between the grounding points, there may be a compensation current via the isolation connected at both sides.

Remedy: Potential compensation line

2.8 General data I/O modules

Structure/dimensions

- Peripheral modules with recessed labeling
- Dimensions of the basic enclosure:
 - 1tier width: (WxHxD) in mm: 40x125x120

Reliability

- Wiring by means of spring pressure connections (CageClamps) at the front connector
- Core cross-section 0.08 ... 2.5mm² or 1.5 mm²
- Total isolation of the wiring at module change
- Potential separation of all modules to the backplane bus

2.8.1 General data

Conformity and approval		
Conformity		
CE	2014/35/EU	Low-voltage directive
	2014/30/EU	EMC directive
Approval		
UL		Refer to Technical data
others		
RoHS	2011/65/EU	Product is lead-free; Restriction of the use of certain hazardous substances in electrical and electronic equipment

Protection of persons and device protection		
Type of protection	-	IP20
Electrical isolation		
to the field bus	-	electrically isolated
to the process level	-	electrically isolated
Insulation resistance		-
Insulation voltage to reference earth		
Inputs / outputs	-	AC / DC 50V, test voltage AC 500V
Protective measures	-	against short circuit

Environmental conditions to EN 61131-2		
Climatic		
Storage / transport	EN 60068-2-14	-25...+70°C
Operation		
Horizontal installation hanging	EN 61131-2	0...+60°C
Horizontal installation lying	EN 61131-2	0...+55°C
Vertical installation	EN 61131-2	0...+50°C
Air humidity	EN 60068-2-30	RH1 (without condensation, rel. humidity 10...95%)
Pollution	EN 61131-2	Degree of pollution 2
Installation altitude max.	-	2000m
Mechanical		

Environmental conditions to EN 61131-2

Oscillation	EN 60068-2-6	1g, 9Hz ... 150Hz
Shock	EN 60068-2-27	15g, 11ms

Mounting conditions

Mounting place	-	In the control cabinet
Mounting position	-	Horizontal and vertical

EMC	Standard	Comment	
Emitted interference	EN 61000-6-4	Class A (Industrial area)	
Noise immunity zone B	EN 61000-6-2	Industrial area	
		EN 61000-4-2	ESD 8kV at air discharge (degree of severity 3), 4kV at contact discharge (degree of severity 2)
		EN 61000-4-3	HF field immunity (casing) 80MHz ... 1000MHz, 10V/m, 80% AM (1kHz) 1.4GHz ... 2.0GHz, 3V/m, 80% AM (1kHz) 2GHz ... 2.7GHz, 1V/m, 80% AM (1kHz)
		EN 61000-4-6	HF conducted 150kHz ... 80MHz, 10V, 80% AM (1kHz)
		EN 61000-4-4	Burst, degree of severity 3
	EN 61000-4-5	Surge, installation class 3 *	

*) Due to the high-energetic single pulses with Surge an appropriate external protective circuit with lightning protection elements like conductors for lightning and overvoltage is necessary.

3 Digital Input Modules

3.1 321-1BH01 - DI 16xDC 24V

Properties

The digital input module collects the binary control signals from the process level and transmits them isolated to the superordinate bus system. It has 16 channels and their status is monitored via LEDs.

- 16 inputs, isolated to the backplane bus
- Nominal input voltage DC 24V
- Useable for switches and approximate switches
- Status monitoring of the channels via LED

Structure

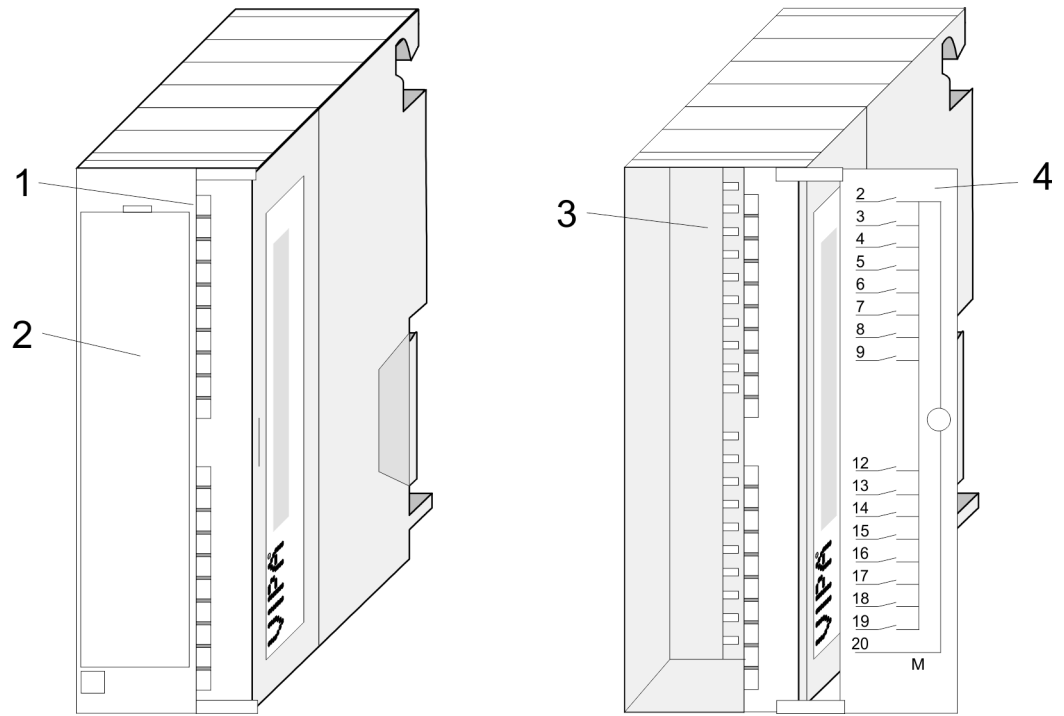

- 1 LEDs
- 2 flap with labeling strip
- 3 contact bar
- 4 flap opened with inner label

Pin assignment Circuit diagram Status monitor

Pin	Assignment	Circuit diagram	LED	Description	
1	not used		.0	LEDs (green)	
2	Input I+0.0		I+0.0 to I+1.7
...7	from ca. 15V on, the signal is recognized as "1" and the according LED is activated
9	Input I+0.7				
12	Input I+1.0				
...	...				
19	Input I+1.7				
20	Ground				

Schematic diagram

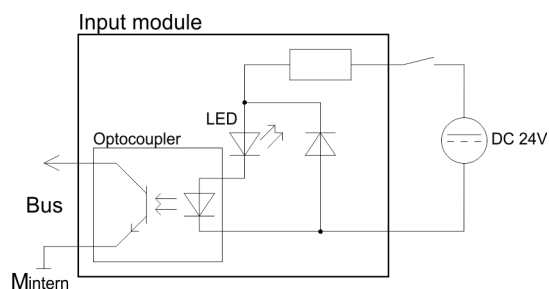

3.1.1 Technical data

Order no.	321-1BH01
Type	SM 321
SPEED-Bus	-
Current consumption/power loss	
Current consumption from backplane bus	25 mA
Power loss	3.5 W
Technical data digital inputs	

Order no.	321-1BH01
Number of inputs	16
Cable length, shielded	1000 m
Cable length, unshielded	600 m
Rated load voltage	-
Current consumption from load voltage L+ (without load)	-
Rated value	DC 20.4...28.8 V
Input voltage for signal "0"	DC 0...5 V
Input voltage for signal "1"	DC 15...28.8 V
Input voltage hysteresis	-
Frequency range	-
Input resistance	-
Input current for signal "1"	7 mA
Connection of Two-Wire-BEROs possible	✓
Max. permissible BERO quiescent current	1.5 mA
Input delay of "0" to "1"	3 ms
Input delay of "1" to "0"	3 ms
Number of simultaneously utilizable inputs horizontal configuration	16
Number of simultaneously utilizable inputs vertical configuration	16
Input characteristic curve	IEC 61131-2, type 1
Initial data size	2 Byte
Status information, alarms, diagnostics	
Status display	green LED per channel
Interrupts	no
Process alarm	no
Diagnostic interrupt	no
Diagnostic functions	no
Diagnostics information read-out	none
Supply voltage display	none
Group error display	none
Channel error display	none
Isolation	
Between channels	-
Between channels of groups to	16
Between channels and backplane bus	✓
Insulation tested with	DC 500 V

Order no.	321-1BH01
Datasizes	
Input bytes	2
Output bytes	0
Parameter bytes	0
Diagnostic bytes	0
Housing	
Material	PPE
Mounting	Rail System 300
Mechanical data	
Dimensions (WxHxD)	40 mm x 125 mm x 120 mm
Weight	220 g
Environmental conditions	
Operating temperature	0 °C to 60 °C
Storage temperature	-25 °C to 70 °C
Certifications	
UL certification	yes
KC certification	yes

3.2 321-1BL00 - DI 32xDC 24V

Properties

The digital input module collects the binary control signals from the process level and transmits them isolated to the superordinate bus system. It has 32 channels and their status is monitored via LEDs.

- 32 inputs, isolated to the backplane bus
- Nominal input voltage DC 24V
- Useable for switches and approximate switches
- Status monitoring of the channels via LED

321-1BL00 - DI 32xDC 24V

Structure

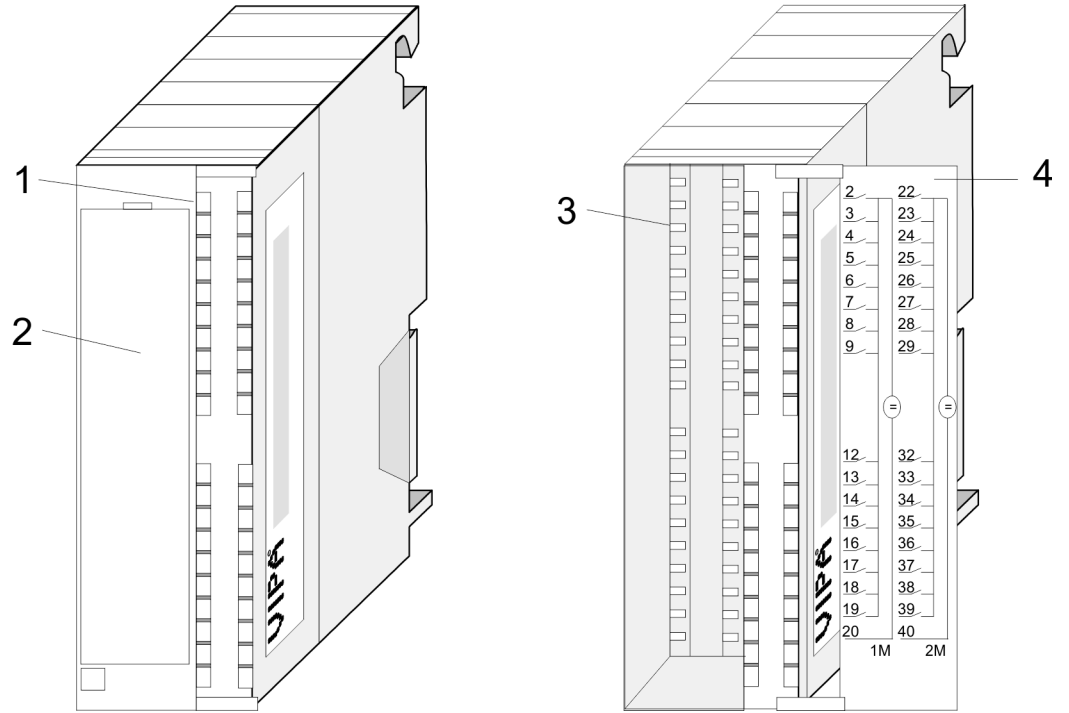

- 1 LEDs
- 2 flap with labeling strip
- 3 contact bar
- 4 flap opened with inner label

Pin assignment Circuit diagram Status monitor

Pin	Assignment	Circuit diagram	LED	Description
1	not used		.0	LEDs (green)
2...9	Input I+0.0...I+0.7			...
12...19	Input I+1.0...I+1.7			.7
20	Ground			
21	not used			
22...29	Input I+2.0...I+2.7			
32...39	Input I+3.0...I+3.7			
40	Ground			

Schematic diagram

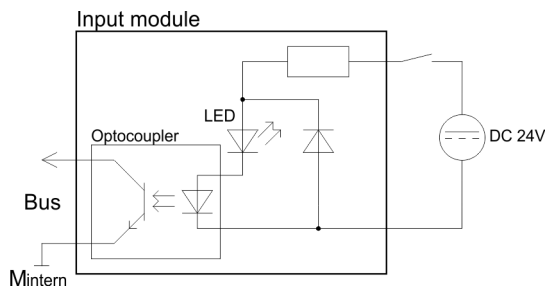

Numeric representation

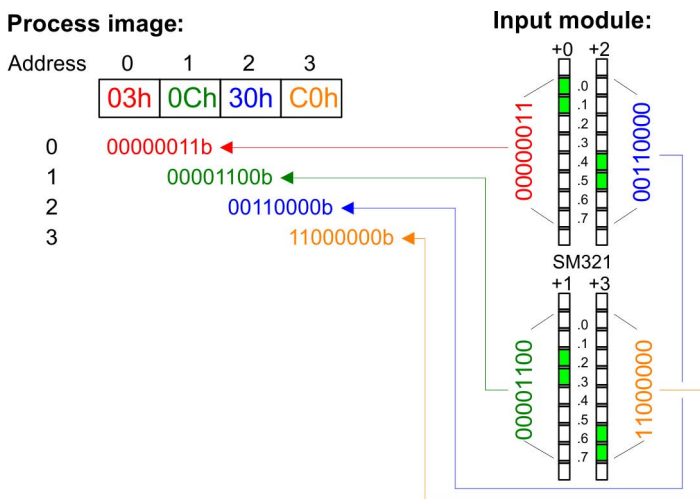

3.2.1 Technical data

Order no.	321-1BL00
Type	SM 321
SPEED-Bus	-
Current consumption/power loss	
Current consumption from backplane bus	35 mA
Power loss	6.5 W
Technical data digital inputs	
Number of inputs	32
Cable length, shielded	1000 m
Cable length, unshielded	600 m
Rated load voltage	-
Current consumption from load voltage L+ (without load)	-
Rated value	DC 20.4...28.8 V
Input voltage for signal "0"	DC 0...5 V
Input voltage for signal "1"	DC 15...28.8 V
Input voltage hysteresis	-
Frequency range	-

Order no.	321-1BL00
Input resistance	-
Input current for signal "1"	7 mA
Connection of Two-Wire-BEROs possible	✓
Max. permissible BERO quiescent current	1.5 mA
Input delay of "0" to "1"	3 ms
Input delay of "1" to "0"	3 ms
Number of simultaneously utilizable inputs horizontal configuration	32
Number of simultaneously utilizable inputs vertical configuration	32
Input characteristic curve	IEC 61131-2, type 1
Initial data size	4 Byte
Status information, alarms, diagnostics	
Status display	green LED per channel
Interrupts	no
Process alarm	no
Diagnostic interrupt	no
Diagnostic functions	no
Diagnostics information read-out	none
Supply voltage display	none
Group error display	none
Channel error display	none
Isolation	
Between channels	-
Between channels of groups to	16
Between channels and backplane bus	✓
Insulation tested with	DC 500 V
Datasizes	
Input bytes	4
Output bytes	0
Parameter bytes	0
Diagnostic bytes	0
Housing	
Material	PPE
Mounting	Rail System 300
Mechanical data	
Dimensions (WxHxD)	40 mm x 125 mm x 120 mm

Order no.	321-1BL00
Weight	240 g
Environmental conditions	
Operating temperature	0 °C to 60 °C
Storage temperature	-25 °C to 70 °C
Certifications	
UL certification	yes
KC certification	yes

3.3 321-1FH00 - DI 16xAC120/230V

Properties

The digital input module collects the binary control signals from the process level and transmits them isolated to the superordinate bus system. It has 16 channels and their status is monitored via LEDs.

- 16 inputs, isolated in groups of 4
- Rated input voltage AC 120/230V
- Useable for switches
- Status monitoring of the channels via LED

Structure

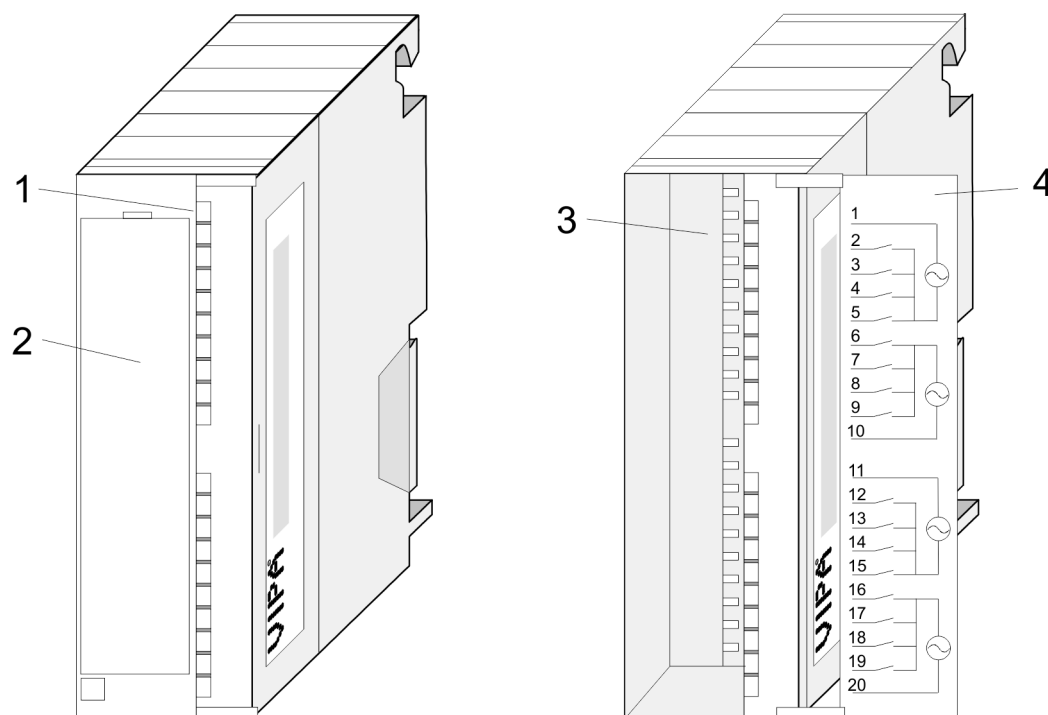

- 1 LEDs
- 2 flap with labeling strip
- 3 contact bar
- 4 flap opened with inner label

321-1FH00 - DI 16xAC120/230V

Pin assignment Circuit diagram Status monitor

Pin	Assignment	Circuit diagram		LED	Description
1	Neutral conductor			.0	LEDs (green)
2	Input I+0.0			...	I+0.0 to I+0.7
3	Input I+0.1				I+1.0 to I+1.7
4	Input I+0.2				from ca. AC 79V on, the signal is recognized as "1" and the according LED is activated
5	Input I+0.3				
6	Input I+0.4				
7	Input I+0.5				
8	Input I+0.6				
9	Input I+0.7				
10	Neutral conductor				
11	Neutral conductor				
12	Input I+1.0				
13	Input I+1.1				
14	Input I+1.2				
15	Input I+1.3				
16	Input I+1.4				
17	Input I+1.5				
18	Input I+1.6				
19	Input I+1.7				
20	Neutral conductor				

Schematic diagram

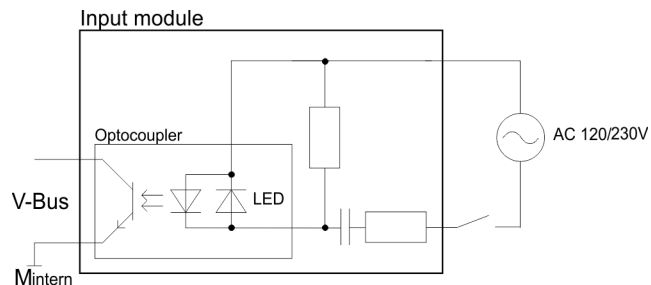

3.3.1 Technical data

Order no.	321-1FH00
Type	SM 321
SPEED-Bus	-
Current consumption/power loss	
Current consumption from backplane bus	35 mA
Power loss	5 W
Technical data digital inputs	
Number of inputs	16
Cable length, shielded	1000 m
Cable length, unshielded	600 m
Rated load voltage	AC 120/230 V
Current consumption from load voltage L+ (without load)	-
Rated value	AC 120/230 V
Input voltage for signal "0"	AC 0...40 V
Input voltage for signal "1"	AC 79...264 V
Input voltage hysteresis	-
Frequency range	47...63 Hz
Input resistance	-
Input current for signal "1"	7 mA
Connection of Two-Wire-BEROs possible	✓
Max. permissible BERO quiescent current	1.5 mA
Input delay of "0" to "1"	25 ms
Input delay of "1" to "0"	25 ms
Number of simultaneously utilizable inputs horizontal configuration	16
Number of simultaneously utilizable inputs vertical configuration	16
Input characteristic curve	-
Initial data size	2 Byte
Status information, alarms, diagnostics	
Status display	green LED per channel
Interrupts	no
Process alarm	no
Diagnostic interrupt	no
Diagnostic functions	no
Diagnostics information read-out	none
Supply voltage display	none

Order no.	321-1FH00
Group error display	none
Channel error display	none
Isolation	
Between channels	✓
Between channels of groups to	4
Between channels and backplane bus	✓
Insulation tested with	DC 4000 V
Datasizes	
Input bytes	2
Output bytes	0
Parameter bytes	0
Diagnostic bytes	0
Housing	
Material	PPE
Mounting	Rail System 300
Mechanical data	
Dimensions (WxHxD)	40 mm x 125 mm x 120 mm
Weight	240 g
Environmental conditions	
Operating temperature	0 °C to 60 °C
Storage temperature	-25 °C to 70 °C
Certifications	
UL certification	yes
KC certification	yes

4 Digital Output Modules

4.1 Safe shutdown of non-safe outputs

4.1.1 Introduction

General

In this section, a security concept is shown, which shows how the safe shutdown of non-safe outputs in the System 300S can be realized.

- The digital output modules in the System 300S are designed stackable.
- The control happens by means of CPU respectively bus coupler via the backplane bus, which has its own power supply.
- Each System 300S output module has its own DC 24V power section supply each group.

Permitted modules



CAUTION!

Please consider hardware version!

Please note that the *safe shutdown* is only possible from the hardware versions listed below!

The following System 300S output modules meet the requirement for safe shutdown:

Article	Name	Hardware version	See page
322-1BH01	SM 322 DO 16xDC 24V 0.5	3	↪ 41
322-1BL00	SM 322 DO 32xDC 24V 1A	4	↪ 54
323-1BL00	SM 323 DI 16xDC 24V, DO 16xDC 24V 1A	5	↪ 80

Scenarios covered by this concept

After emergency shutdown according to ↪ 4.1.2, safe shutdown is ensured even if the following error scenarios occur:

- Overvoltage on the control side
- Short circuit by a power supply on the field side
- Short circuit on the field side within a group
- Failure of components in the module

4.1.2 Safe shutdown

Proceeding

The *safe shutdown* is exclusively supported by the modules listed above. For the *safe shutdown* connect a safety switch such as an emergency stop, as shown in the figure, so that if pressed both lines of the DC 24V power section supply of the group of the corresponding System 300S module is switched off. In this case, the safety switch must have an approval according to the current safety standards.

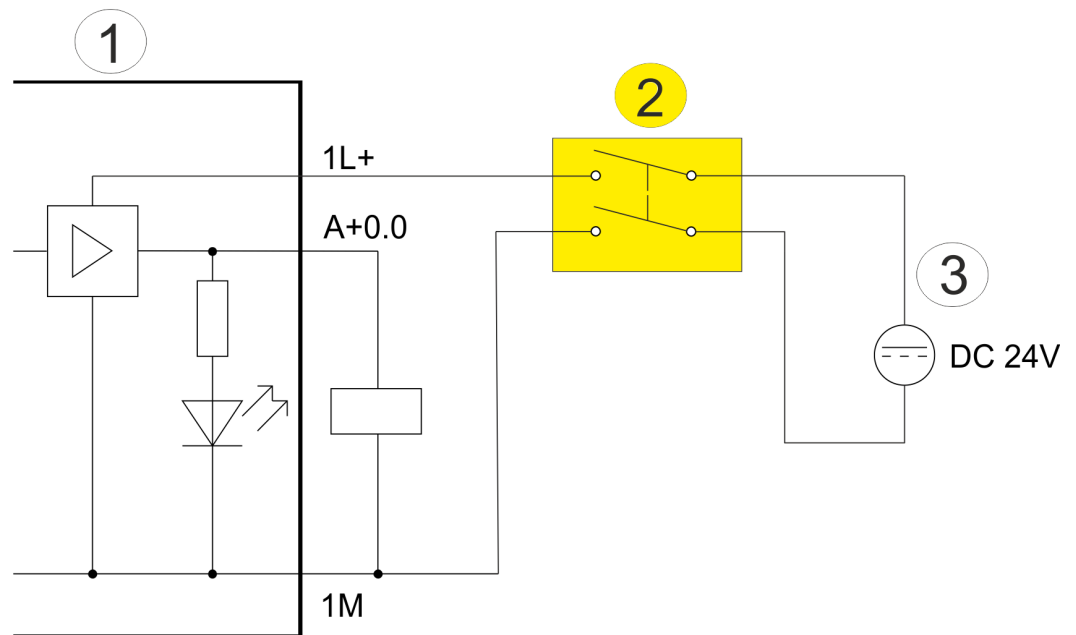

- 1 System 300S output module (group)
- 2 Safety switch
- 3 DC 24V power section supply

4.1.3 Requirements and fault exclusions

Precondition

On this way the product reaches a MTTdF value (**Mean Time To dangerous Failure: Mean time to dangerous failure of infinite and is not considered at the DCavg calculation (Diagnostic Coverage average)**):

- The power supply for DC 24V power section supply and electronic power supply of head station and modules must be certified and tested SELV or PELV.
 - So on error the maximum output voltage is $U_m = \text{DC } 60\text{V}$.
 - This applies to all power supplies, which are connected to the System 300S.
 - This also applies to sensor signals that are connected to digital or analog inputs of a DI module. These must also be supplied with SELF/PELV power supplies.
- When using PELV power supplies, no actuator which is used for safe disconnection must have a connection from GND to ground, since otherwise a two-pole disconnection by the safety switch is not possible.
- The place of installation for the device is a cabinet with degree of protection IP54 or better.
- The installation and connection of the cables must be in accordance to EN 60204-1 and comply with the measures of EN ISO 13849-2 table D.4. If multiple power supplies are collected to a multi-conductor cable, which are not switched off together on the safety switch device, then the following is required:
 - A safe laying e.g. in a cabinet without moving parts and without excessive heating or e.g. in separate cable ducts with overrun protection
 - or
 - the use of cross-circuit-proof cables this means individually shielded cables for the power supplies and the output signals to be switched off.
- The DC 24V electronic and power section supply must be protected by an appropriately sized fuse against exceeding the respective total current.

- Actuators which are connected to the outputs of the DO modules are:
 - not allowed switching-on a maximum leak current of 2mA
and
 - not allowed switching-on at an output voltage of up to 5V.

(This corresponds to the low-level definition for digital outputs according to IEC 61131-2)
- The shutdown of the DC 24V power supply by an upstream safety switch device must be checked and documented before the plant is commissioned.
 - This verification is to be regularly carried out (at least once a year) and the results are to be documented.
 - On a malfunction of the safety function, the error must be searched and corrected.
 - Commissioning is not allowed until the error is corrected!
- The safety switch must have an approval corresponding to the performance level required for the application.
- The use of the DO modules for safe shutdown is only permissible for safety functions according to EN ISO 13849-1 to category 3 PLd.
- The product may be used up to a maximum of 2000m above sea level.
- The environmental conditions in the technical specifications of the modules must be respected.
- The following lists the fault exclusions that are used within the concept of safe shutdown and which must be complied with in the DO modules developed for this purpose. Do not change the prerequisites for this fault exclusions.
Fault exclusion according to EN ISO 13849-2 D.5 (short circuit between adjacent conductors / contact points) justified by:
 - Basic material at least EP GC according to IEC60893-1
 - Power supply with SELV/PELV
 - Degree of pollution 2
 - Overvoltage category III, double insulation:
Clearances $\geq 0.5\text{mm}$, Creepage distances $\geq 0.5\text{mm}$ and installation in an enclosure with a degree of protection of at least IP54
 - Deployment maximal 2000m above N.N.
- Fault exclusion according to EN ISO 13849-2 D.7 (short circuit between each adjacent connector pin) justified by:
 - Degree of pollution 2
 - Overvoltage category III, double insulation:
Clearances $\geq 0.5\text{mm}$, Creepage distances $\geq 1.06\text{mm}$
 - Deployment maximal 2000 m above N.N.
- Fault exclusion according to EN ISO 13849-2 D.19 (short circuit between input and output of the opto coupler justified by:
 - Pulse withstanding capacity greater than IEC 60664-1: 2003, Table 1,
 - Overvoltage category III, double insulation:
 - Degree of pollution 2
 - Power supply with SELV/PELV
 - Measures for avoiding a temperature rise due to a fault which can lead to damage to the insulating materials of the opto coupler and its potential separation.

4.2 322-1BF01 - DO 8xDC 24V 2A

Properties

The digital output module collects the binary control signals from the superordinate bus system and transmits them isolated to the process level. The module has to be provided with 24V via the front slot. It has 8 channels and their status is monitored via LEDs.

- 8 outputs, potential separated to the back panel bus
- supply voltage DC 24V, output voltage 2A
- useable for magnetic valve and DC contactor
- LEDs for supply voltage and error messages
- Status monitoring of the channels via LED

Structure

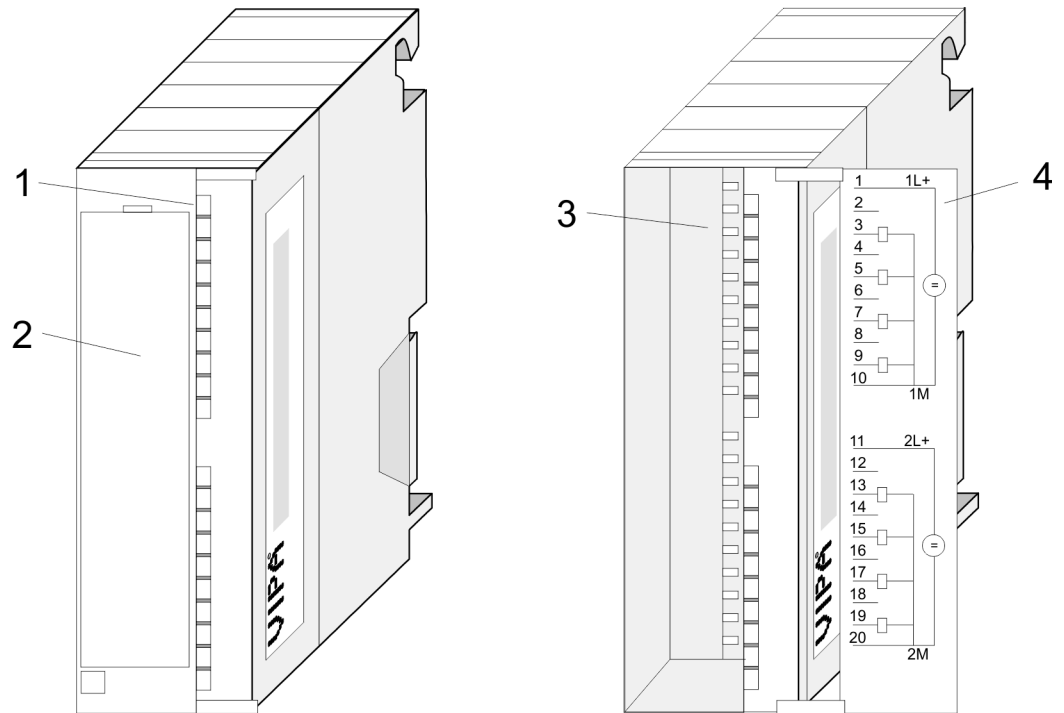

- 1 LEDs
- 2 flap with labeling strip
- 3 contact bar
- 4 flap opened with inner label

Pin assignment Circuit diagram Status monitor

Pin	Assignment	Circuit diagram		LED	Description
1	Supply voltage DC 24V (1L+)			1L+, 2L+	LED (green) supply voltage is on
3	Output Q+0.0			.0	LEDs (green) Q+0.0 to Q+0.7
5	Output Q+0.1			.1	As soon as an output is active, the according LED is activated
7	Output Q+0.2			.2	
9	Output Q+0.3			.3	
10	Ground 1			F	LED (red) Error when overload or short circuits
11	Supply voltage DC 24V (2L+)			2L+	
13	Output Q+0.4			4	
15	Output Q+0.5			.5	
17	Output Q+0.6			.6	
19	Output Q+0.7	.7			
20	Ground 2	F			

Schematic diagram

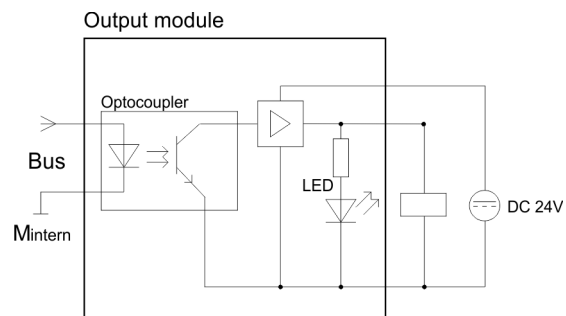

4.2.1 Technical data

Order no.	322-1BF01
Type	SM 322
SPEED-Bus	-
Current consumption/power loss	
Current consumption from backplane bus	65 mA
Power loss	7.5 W

Order no.	322-1BF01
Technical data digital outputs	
Number of outputs	8
Cable length, shielded	1000 m
Cable length, unshielded	600 m
Rated load voltage	DC 24 V
Current consumption from load voltage L+ (without load)	68 mA
Total current per group, horizontal configuration, 40°C	8 A
Total current per group, horizontal configuration, 60°C	8 A
Total current per group, vertical configuration	8 A
Output current at signal "1", rated value	2 A
Output delay of "0" to "1"	150 µs
Output delay of "1" to "0"	100 µs
Minimum load current	-
Lamp load	10 W
Parallel switching of outputs for redundant control of a load	possible (only outputs group)
Parallel switching of outputs for increased power	possible (only outputs group)
Actuation of digital input	✓
Switching frequency with resistive load	max. 1000 Hz
Switching frequency with inductive load	max. 0.5 Hz
Switching frequency on lamp load	max. 10 Hz
Internal limitation of inductive shut-off voltage	L+ (-52 V)
Short-circuit protection of output	yes, electronic
Trigger level	3 A
Number of operating cycle of relay outputs	-
Switching capacity of contacts	-
Output data size	1 Byte
Status information, alarms, diagnostics	
Status display	green LED per channel
Interrupts	no
Process alarm	no
Diagnostic interrupt	no
Diagnostic functions	no
Diagnostics information read-out	none
Supply voltage display	green LED per group
Group error display	red SF LED
Channel error display	none

Order no.	322-1BF01
Isolation	
Between channels	✓
Between channels of groups to	4
Between channels and backplane bus	✓
Insulation tested with	DC 500 V
Datasizes	
Input bytes	0
Output bytes	1
Parameter bytes	0
Diagnostic bytes	0
Housing	
Material	PPE
Mounting	Rail System 300
Mechanical data	
Dimensions (WxHxD)	40 mm x 125 mm x 120 mm
Weight	240 g
Environmental conditions	
Operating temperature	0 °C to 60 °C
Storage temperature	-25 °C to 70 °C
Certifications	
UL certification	yes
KC certification	yes

4.3 322-1BH01 - DO 16xDC 24V 1A

Properties

The digital output module collects the binary control signals from the superordinate bus system and transmits them isolated to the process level. The module has to be provided with 24V via the front slot. It has 16 channels and their status is monitored via LEDs.

- 16 outputs, potential separated to the back panel bus
- supply voltage DC 24V, output voltage 1A
- useable for magnetic valve and DC contactor
- LEDs for supply voltage and error messages
- Status monitoring of the channels via LED
- Starting from hardware version 3 *safe shutdown* is supported. ↪ Chapter 4.1 'Safe shutdown of non-safe outputs' on page 35

322-1BH01 - DO 16xDC 24V 1A

Structure

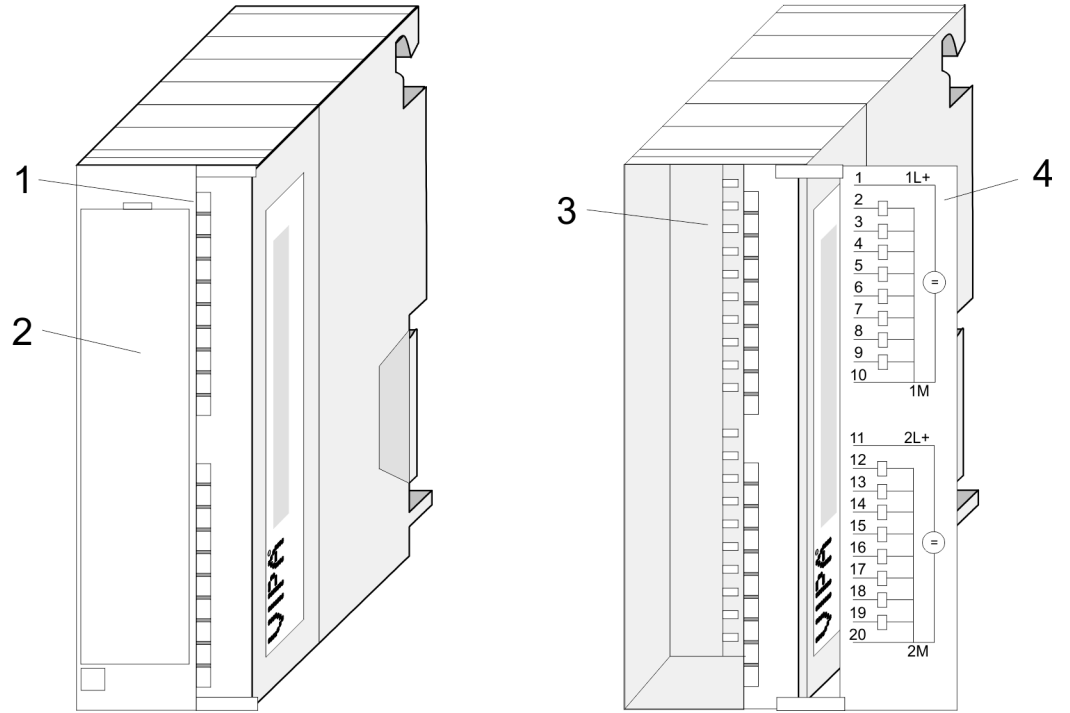

- 1 LEDs
- 2 flap with labeling strip
- 3 contact bar
- 4 flap opened with inner label

Pin assignment Circuit diagram Status monitor

Pin	Assignment	Circuit diagram	LED	Description	
1	Supply voltage DC 24V (1L+)		1L+, 2L+	LED (green) supply voltage is on	
2	Output Q+0.0		.0	LEDs (green) Q+0.0 to Q+1.7	
...7	As soon as an output is active, the according LED is activated
9	Output Q+0.7			F	LED (red) Error when overload or short circuits
10	Ground 1			2L+	
11	Supply voltage DC 24V (2L+)			.0	
12	Output Q+1.0			.1	
...	
19	Output Q+1.7		.7		
20	Ground 2		F		

Schematic diagram

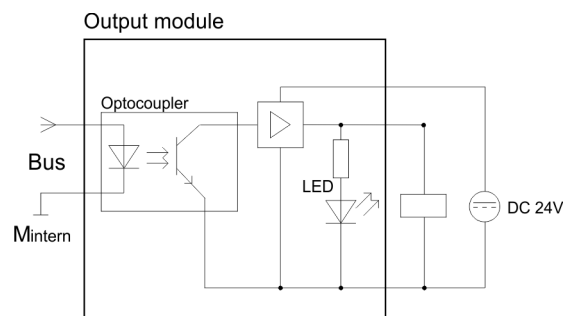

4.3.1 Technical data

Order no.	322-1BH01
Type	SM 322
SPEED-Bus	-
Current consumption/power loss	
Current consumption from backplane bus	110 mA
Power loss	4 W

Order no.	322-1BH01
Technical data digital outputs	
Number of outputs	16
Cable length, shielded	1000 m
Cable length, unshielded	600 m
Rated load voltage	DC 24 V
Current consumption from load voltage L+ (without load)	30 mA
Total current per group, horizontal configuration, 40°C	4 A
Total current per group, horizontal configuration, 60°C	4 A
Total current per group, vertical configuration	4 A
Output current at signal "1", rated value	1 A
Output delay of "0" to "1"	150 µs
Output delay of "1" to "0"	100 µs
Minimum load current	-
Lamp load	5 W
Parallel switching of outputs for redundant control of a load	possible (only outputs group)
Parallel switching of outputs for increased power	not possible
Actuation of digital input	✓
Switching frequency with resistive load	max. 1000 Hz
Switching frequency with inductive load	max. 0.5 Hz
Switching frequency on lamp load	max. 10 Hz
Internal limitation of inductive shut-off voltage	L+ (-45 V)
Short-circuit protection of output	yes, electronic
Trigger level	1.5 A
Number of operating cycle of relay outputs	-
Switching capacity of contacts	-
Output data size	2 Byte
Status information, alarms, diagnostics	
Status display	green LED per channel
Interrupts	no
Process alarm	no
Diagnostic interrupt	no
Diagnostic functions	no
Diagnostics information read-out	none
Supply voltage display	green LED per group
Group error display	red SF LED
Channel error display	none

Order no.	322-1BH01
Isolation	
Between channels	✓
Between channels of groups to	8
Between channels and backplane bus	✓
Insulation tested with	DC 500 V
Datasizes	
Input bytes	0
Output bytes	2
Parameter bytes	0
Diagnostic bytes	0
Housing	
Material	PPE
Mounting	Rail System 300
Mechanical data	
Dimensions (WxHxD)	40 mm x 125 mm x 120 mm
Net weight	230 g
Weight including accessories	-
Gross weight	-
Environmental conditions	
Operating temperature	0 °C to 60 °C
Storage temperature	-25 °C to 70 °C
Certifications	
UL certification	yes
KC certification	yes

4.4 322-1BH41 - DO 16xDC 24V 2A

Properties

The digital output module collects the binary control signals from the superordinate bus system and transmits them isolated to the process level. The module has to be provided with 24V via the front slot. It has 16 channels and their status is monitored via LEDs.

- 16 outputs, potential separated to the back panel bus
- supply voltage DC 24V, output voltage 2A
- useable for magnetic valve and DC contactor
- LEDs for supply voltage and error messages
- Status monitoring of the channels via LED

322-1BH41 - DO 16xDC 24V 2A

Structure

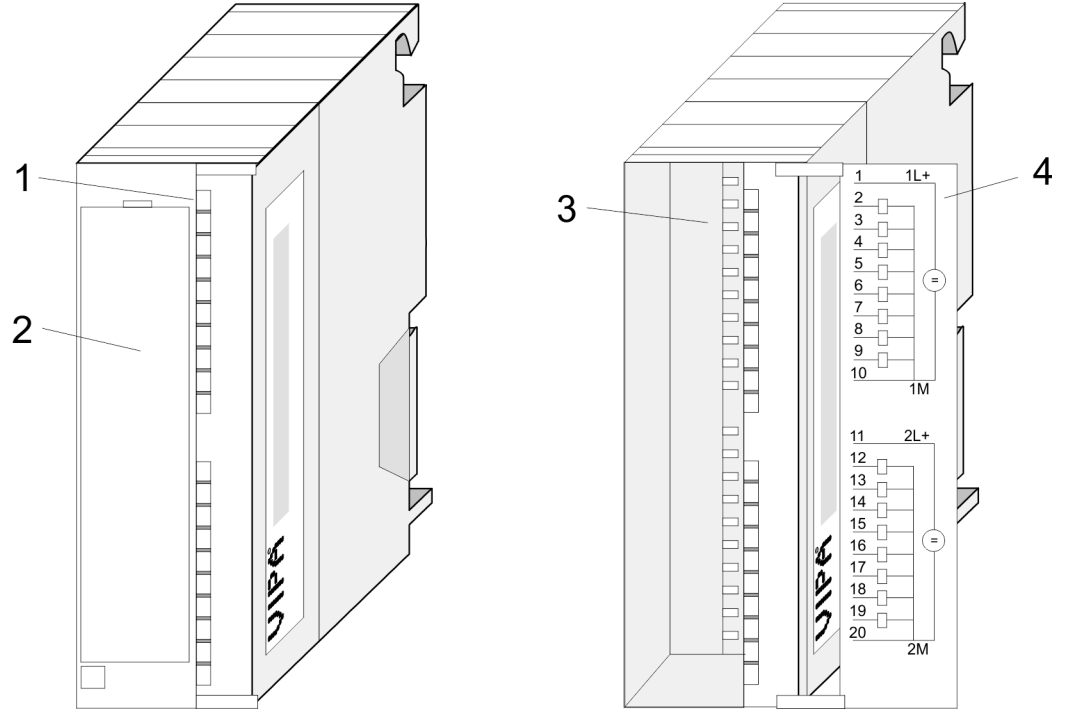

- 1 LEDs
- 2 flap with labeling strip
- 3 contact bar
- 4 flap opened with inner label

Pin assignment Circuit diagram Status monitor

Pin	Assignment	Circuit diagram	LED	Description	
1	Supply voltage DC 24V (1L+)		1L+, 2L+	LED (green) supply voltage is on	
2	Output Q+0.0		.0	LEDs (green) Q+0.0 to Q+1.7 As soon as an output is active, the according LED is turned on	
...		
9	Output Q+0.7		.7		
10	Ground 1		F		
11	Supply voltage DC 24V (2L+)		2L+		LED (red) Error when overload or short circuits
12	Output Q+1.0		.0		
...		
19	Output Q+1.7		.7		
20	Ground 2		F		

Schematic diagram

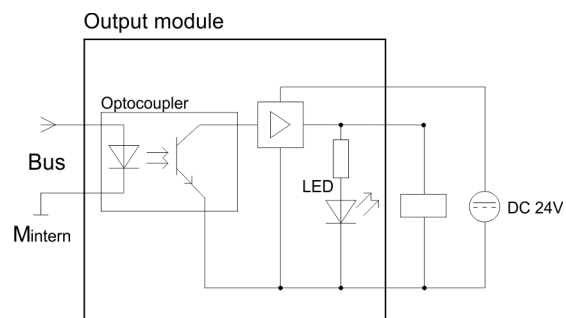

Project engineering



Project engineering as 322-1BH01!

4.4.1 Technical data

Order no.	322-1BH41
Type	SM 322
SPEED-Bus	-
Current consumption/power loss	
Current consumption from backplane bus	110 mA
Power loss	4 W
Technical data digital outputs	
Number of outputs	16
Cable length, shielded	1000 m
Cable length, unshielded	600 m
Rated load voltage	DC 24 V
Current consumption from load voltage L+ (without load)	30 mA
Total current per group, horizontal configuration, 40°C	8 A
Total current per group, horizontal configuration, 60°C	8 A
Total current per group, vertical configuration	8 A
Output current at signal "1", rated value	2 A
Output delay of "0" to "1"	150 µs
Output delay of "1" to "0"	100 µs
Minimum load current	-
Lamp load	10 W
Parallel switching of outputs for redundant control of a load	possible (only outputs group)
Parallel switching of outputs for increased power	possible (only outputs group)
Actuation of digital input	✓
Switching frequency with resistive load	max. 1000 Hz
Switching frequency with inductive load	max. 0.5 Hz
Switching frequency on lamp load	max. 10 Hz
Internal limitation of inductive shut-off voltage	L+ (-52 V)
Short-circuit protection of output	yes, electronic
Trigger level	3 A
Number of operating cycle of relay outputs	-
Switching capacity of contacts	-
Output data size	2 Byte
Status information, alarms, diagnostics	
Status display	green LED per channel
Interrupts	no
Process alarm	no

Order no.	322-1BH41
Diagnostic interrupt	no
Diagnostic functions	no
Diagnostics information read-out	none
Supply voltage display	green LED per group
Group error display	red SF LED
Channel error display	none
Isolation	
Between channels	✓
Between channels of groups to	8
Between channels and backplane bus	✓
Insulation tested with	DC 500 V
Datasizes	
Input bytes	0
Output bytes	2
Parameter bytes	0
Diagnostic bytes	0
Housing	
Material	PPE
Mounting	Rail System 300
Mechanical data	
Dimensions (WxHxD)	40 mm x 125 mm x 120 mm
Weight	230 g
Environmental conditions	
Operating temperature	0 °C to 60 °C
Storage temperature	-25 °C to 70 °C
Certifications	
UL certification	yes
KC certification	yes

4.5 322-1BH60 - DO 16xDC 24V 0.5A for manual operation

Properties

The module is configured as in-/output module. It has 16 channels and their status is monitored via LEDs. Besides of the LEDs the front provides a row of switches for manual res. Automatic operation, i.e. every output has a 3 setting switch with the positions auto-
matic, manual 0 and manual 1.

- 16 outputs, potential separated to the back panel bus
- 1 input, potential separated, for activation of all outputs
- 3 setting switch per channel (automatic, manual 0 and manual 1)
- 16 inputs, switch status via input word
- supply voltage DC 24V, output voltage 0.5A
- LEDs for supply voltage and error messages
- Status monitoring of the channels via LED

Structure

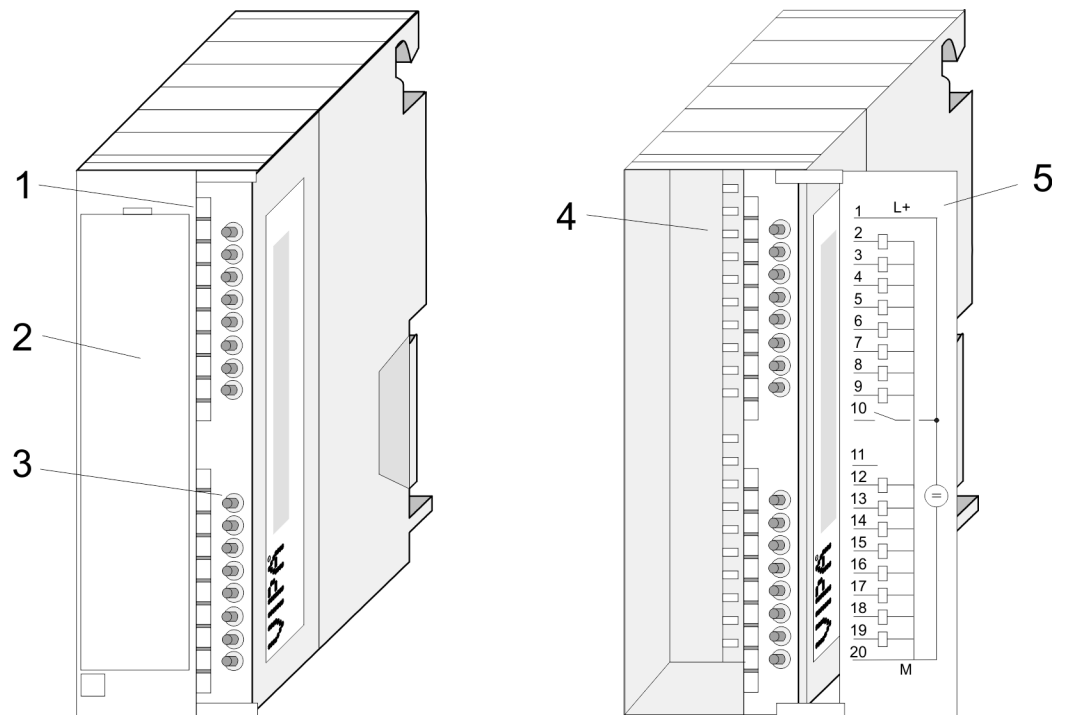

- 1 LEDs
- 2 flap with labeling strip
- 3 switch bar
- 4 contact bar
- 5 flap opened with inner label

Pin assignment Circuit diagram Status monitor

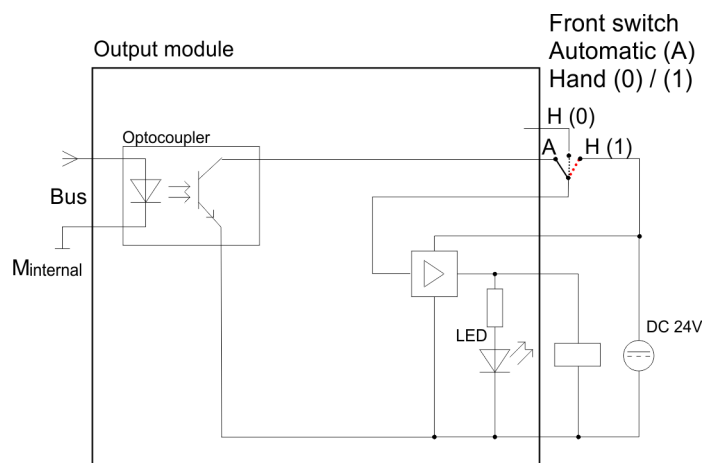

Pin	Assignment	Circuit diagram	LED	Description
1	Supply voltage DC 24V		L+	LED (green) supply voltage is on
2	Output Q+0.0		.0	LEDs (green) Q+0.0 to Q+1.7 As soon as an output is active, the according LED is turned on
3			1	
4			2	
5			3	
6			4	
7			5	
8			6	
9	Output Q+0.7		7	
10	Input for Q.x="1"		10 A	LED (red) Error when overload or short circuits
11	n.c.		+1	
12	Output Q+1.0		0	
13			1	
14			2	
15	Output O+1.7		3	
16			4	
17			5	
18			6	
19			7	
20	Ground		F	

Schematic diagram



4.5.1 Deployment

Please regard that the module is installed as 323-1BL00. You are allowed to request the switch position of the according channel via the input word. For this is valid:

triple switch	input word	Description
 10A	I.x = 0	Manual 1: output channel always activated
 10A	I.x = 0	Manual 0: output channel always de-activated
 10A	I.x = 0	Automatic: control via PLC application

The control of the outputs happens via output word.



By connecting DC 24V at the input (Pin 10), all outputs are set to "1". This input cannot be evaluated by the PLC user program.

Project engineering



Project engineering as 323-1BL00!

4.5.2 Technical data

Order no.	322-1BH60
Type	SM 322
SPEED-Bus	-
Current consumption/power loss	
Current consumption from backplane bus	100 mA
Power loss	6 W
Technical data digital outputs	
Number of outputs	16
Cable length, shielded	1000 m
Cable length, unshielded	600 m
Rated load voltage	DC 24 V
Current consumption from load voltage L+ (without load)	140 mA
Total current per group, horizontal configuration, 40°C	8 A
Total current per group, horizontal configuration, 60°C	8 A

Order no.	322-1BH60
Total current per group, vertical configuration	8 A
Output current at signal "1", rated value	0.5 A
Output delay of "0" to "1"	max. 100 µs
Output delay of "1" to "0"	max. 500 µs
Minimum load current	-
Lamp load	5 W
Parallel switching of outputs for redundant control of a load	not possible
Parallel switching of outputs for increased power	not possible
Actuation of digital input	✓
Switching frequency with resistive load	max. 1000 Hz
Switching frequency with inductive load	max. 0.5 Hz
Switching frequency on lamp load	max. 10 Hz
Internal limitation of inductive shut-off voltage	L+ (-52 V)
Short-circuit protection of output	yes, electronic
Trigger level	1 A
Number of operating cycle of relay outputs	-
Switching capacity of contacts	-
Output data size	2 Byte
Status information, alarms, diagnostics	
Status display	green LED per channel
Interrupts	no
Process alarm	no
Diagnostic interrupt	no
Diagnostic functions	no
Diagnostics information read-out	none
Supply voltage display	green LED per group
Group error display	red SF LED
Channel error display	none
Isolation	
Between channels	-
Between channels of groups to	16
Between channels and backplane bus	✓
Insulation tested with	DC 500 V
Datasizes	
Input bytes	0
Output bytes	2

322-1BL00 - DO 32xDC 24V 1A

Order no.	322-1BH60
Parameter bytes	0
Diagnostic bytes	0
Housing	
Material	PPE
Mounting	Rail System 300
Mechanical data	
Dimensions (WxHxD)	40 mm x 125 mm x 120 mm
Weight	230 g
Environmental conditions	
Operating temperature	0 °C to 60 °C
Storage temperature	-25 °C to 70 °C
Certifications	
UL certification	yes
KC certification	yes

4.6 322-1BL00 - DO 32xDC 24V 1A

Properties

The digital output module collects the binary control signals from the superordinate bus system and transmits them isolated to the process level. The module has to be provided with 24V via the front slot. It has 16 channels and their status is monitored via LEDs.

- 32 outputs, potential separated to the back panel bus
- Supply voltage DC 24V
- Output voltage 1A per channel
- Useable for magnetic valve and DC contactor
- LEDs for supply voltage and error messages
- Activity LED per channel
- Starting from hardware version 4 *safe shutdown* is supported. ↪ [Chapter 4.1 'Safe shutdown of non-safe outputs'](#) on page 35

Structure

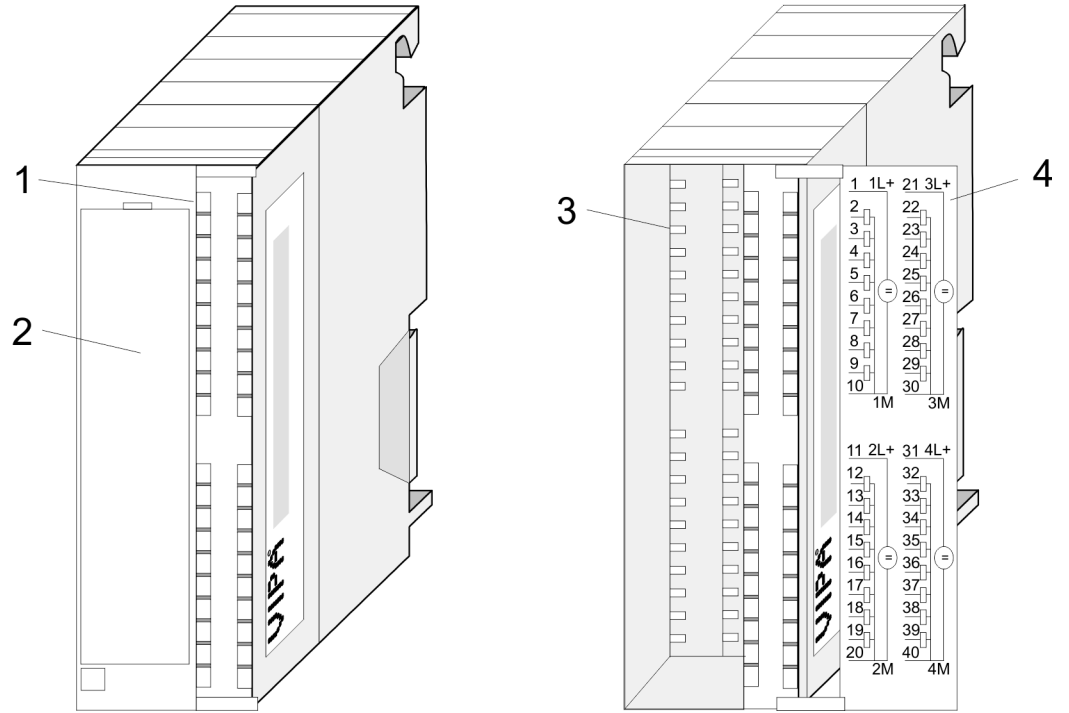

- 1 LEDs
- 2 flap with labeling strip
- 3 contact bar
- 4 flap opened with inner label

322-1BL00 - DO 32xDC 24V 1A

Pin assignment Circuit diagram Status monitor

Pin	Assignment	Circuit diagram		LED	Description		
1	Supply voltage 1L+			1/3L+, 2/4L+	LED (green) supply voltage is on		
2	Output Q+0.0			.0	LEDs (green) Q+0.0 to Q+3.7		
...		
9	Output Q+0.7			.7	As soon as an output is active, the according LED is turned on		
10	Ground 1			1/3F, 2/4F	LED (red) Error when overload or short circuits		
11	Supply voltage 2L+						
12	Output Q+1.0					.0	
...	
19	Output Q+1.7					.7	
20	Ground 2						
21	Supply voltage 3L+						
22	Output Q+2.0					.0	
...	
29	Output Q+2.7					.7	
30	Ground 3						
31	Supply voltage 4L+						
32	Output Q+3.0					.0	
...	
39	Output Q+3.7					.7	
40	Ground 4						

Schematic diagram

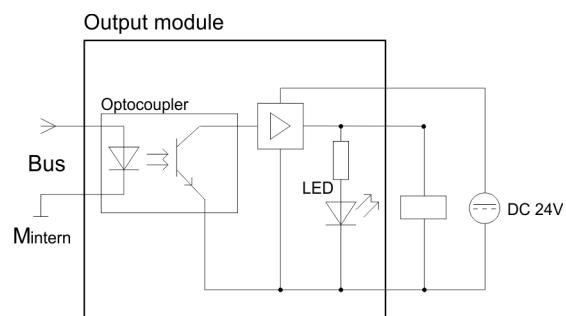

4.6.1 Deployment

Numeric representation

From the application level to the hardware level the data is stored in Motorola-Format, i.e. "ready for reading". The following picture shows the output of the number 287454020dez res. 11223344hex on the outputs of the 32pin output modules

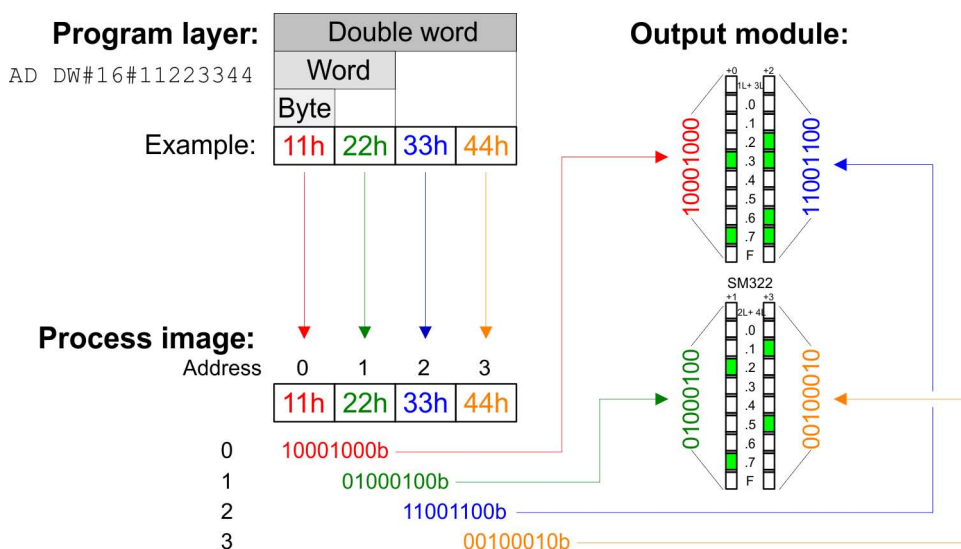

4.6.2 Technical data

Order no.	322-1BL00
Type	SM 322
SPEED-Bus	-
Current consumption/power loss	
Current consumption from backplane bus	200 mA
Power loss	6 W
Technical data digital outputs	
Number of outputs	32
Cable length, shielded	1000 m
Cable length, unshielded	600 m
Rated load voltage	DC 24 V
Current consumption from load voltage L+ (without load)	30 mA
Total current per group, horizontal configuration, 40°C	2.5 A
Total current per group, horizontal configuration, 60°C	2.5 A
Total current per group, vertical configuration	2.5 A
Output current at signal "1", rated value	1 A
Output delay of "0" to "1"	150 µs
Output delay of "1" to "0"	100 µs
Minimum load current	-
Lamp load	5 W

Order no.	322-1BL00
Parallel switching of outputs for redundant control of a load	possible (only outputs group)
Parallel switching of outputs for increased power	not possible
Actuation of digital input	✓
Switching frequency with resistive load	max. 1000 Hz
Switching frequency with inductive load	max. 0.5 Hz
Switching frequency on lamp load	max. 1 Hz
Internal limitation of inductive shut-off voltage	L+ (-45 V)
Short-circuit protection of output	yes, electronic
Trigger level	1.5 A
Number of operating cycle of relay outputs	-
Switching capacity of contacts	-
Output data size	4 Byte
Status information, alarms, diagnostics	
Status display	green LED per channel
Interrupts	no
Process alarm	no
Diagnostic interrupt	no
Diagnostic functions	no
Diagnostics information read-out	none
Supply voltage display	green LED per group
Group error display	red SF LED
Channel error display	none
Isolation	
Between channels	✓
Between channels of groups to	8
Between channels and backplane bus	✓
Insulation tested with	DC 500 V
Datasizes	
Input bytes	0
Output bytes	4
Parameter bytes	0
Diagnostic bytes	0
Housing	
Material	PPE
Mounting	Rail System 300
Mechanical data	

Order no.	322-1BL00
Dimensions (WxHxD)	40 mm x 125 mm x 120 mm
Net weight	260 g
Weight including accessories	-
Gross weight	-
Environmental conditions	
Operating temperature	0 °C to 60 °C
Storage temperature	-25 °C to 70 °C
Certifications	
UL certification	yes
KC certification	yes

4.7 322-5FF00 - DO 8xAC 120/230V 2A

Properties

The digital output module collects the binary control signals from the superordinate bus system and transmits them isolated to the process level. It has 8 channels and their status is monitored via LEDs.

- 8 outputs, isolated between the channels and to the back plane bus
- Rated load voltage AC 120/230V
- Output current per channel 2A
- Suitable for AC solenoid valves, contactors, motor starters, fractional h.p. motors and indicator lights
- Group error display
- Channel-specific status LEDs
- Programmable substitute value output

322-5FF00 - DO 8xAC 120/230V 2A

Structure

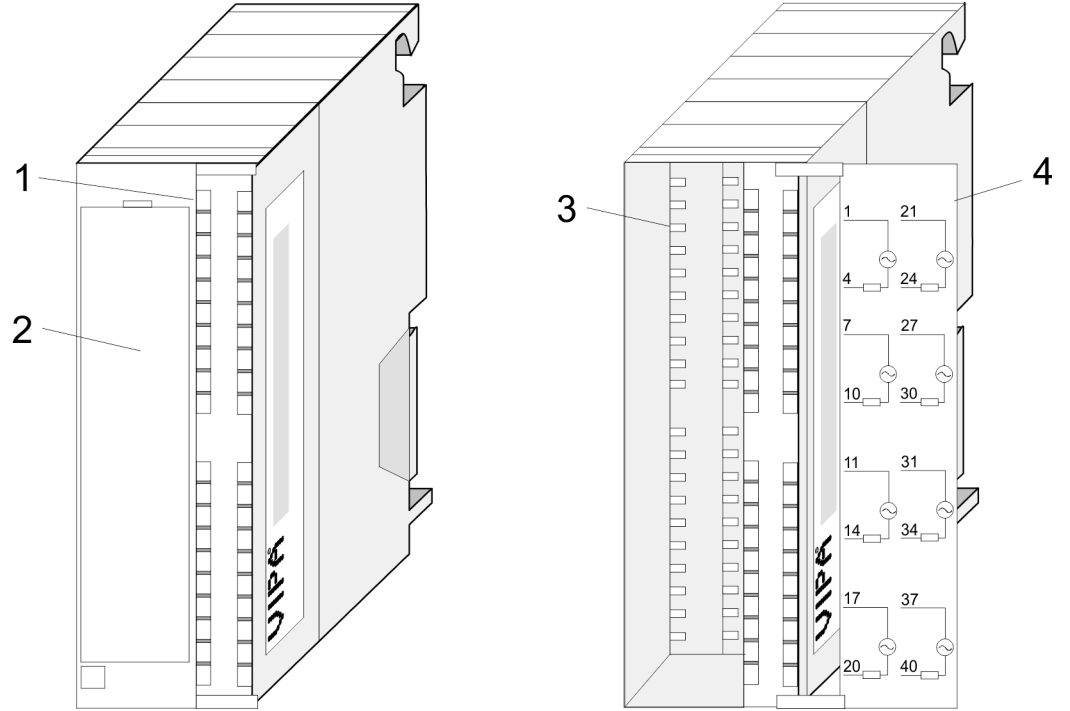

- 1 LEDs
- 2 flap with labeling strip
- 3 contact bar
- 4 flap opened with inner label

Pin assignment Circuit diagram Status monitor

Pin	Assignment	Circuit diagram		LED	Description
1	Rated load voltage 1L			SF	LED (red) Group error LED, error if module is not supplied with param- eters by the CPU
4	Q+0.0			.0	LED (green) Q+0.0 to Q+0.7
7	Rated load voltage 2L			.1	As soon as an output is active, the according LED is turned on
10	Q+0.1			.2	
11	Rated load voltage 3L			.3	
14	Q+0.2			.4	
17	Rated load voltage 4L			.5	
20	Q+0.3			.6	
21	Rated load voltage 5L			.7	
24	Q+0.4				
27	Rated load voltage 6L				
30	Q+0.5				
31	Rated load voltage 7L				
34	Q+0.6				
37	Rated load voltage 8L				
40	Q+0.7				

Schematic diagram

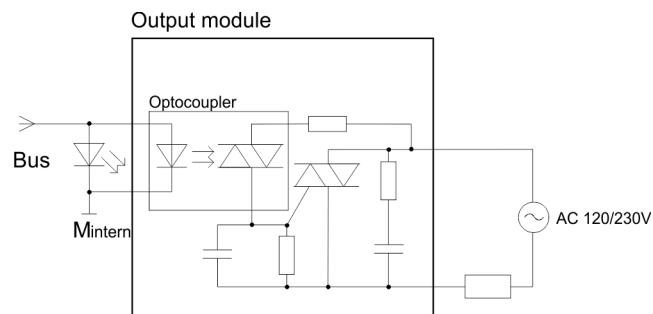

**CAUTION!**

The outputs must be protected by a fast-acting 3.15A, AC 250V fuse. When mounted in a hazardous area, the fuse may only be removed by a tool.

4.7.1 Parameterization

Overview

There are the following possibilities for parameterization:

- Parameterization by WinPLC7 from VIPA or by hardware configuration of Siemens SIMATIC manager.
- Parameterization during run time by means of SFCs

Parameterization by hardware configuration

To be compatible to the Siemens SIMATIC manager the following steps are to be accomplished:

1. Start the hardware configurator from Siemens.
2. Create a new project.
3. Configure your CPU.
4. Link-up your System 300V modules in the plugged-in sequence starting with slot 4.

Here the digital output modules of VIPA are to be projected as digital output modules of Siemens in accordance with the following rules:

VIPA 322-5FF00 to be configured as **6ES7 322-5FF00-0AB0**

The digital output modules can be found at the hardware catalog at *Simatic 300 > SM-300*.

5. If needed parameterize the CPU respectively the modules. The parameter window appears as soon as you double click on the according module. At this window the according parameter can be changed.
6. Save your project, switch the CPU to STOP and transfer your project to the CPU. As soon as the CPU is switched to RUN the parameters are transferred to the connected modules.

Parameters

The following parameters can be adjusted at the digital output modules:

- Reaction at CPU-STOP
- Switch substitute value "1"

More description of the parameters may be found at the following pages.

Parameterization during run time by means of SFCs

If the module gets parameters, which are not supported by the module, for example a current module is to be configured as a voltage module, these parameters are interpreted as wrong parameters and an error is initialized. At the parameterization, a 4byte long parameter area is set in the record set 1. Deploying the SFCs 56, 57 and the SFB 53, you may alter parameters during run time and transfer them to the module.

Parameter Record set 1

Record set 1 (Byte 0 to 3):

Byte	Bit 7 ... Bit 0	Default value
0	Reaction to CPU Stop <ul style="list-style-type: none"> ■ Bit 0: Keep last valid value ■ Bit 1: Substitute a value ■ Bit 6: reserved ■ Bit 7: reserved 	00h
1	Substitute value <ul style="list-style-type: none"> ■ Bit 0: Substitute value "1" on channel 0 ■ Bit 1: Substitute value "1" on channel 1 ■ Bit 2: Substitute value "1" on channel 2 ■ Bit 3: Substitute value "1" on channel 3 ■ Bit 4: Substitute value "1" on channel 4 ■ Bit 5: Substitute value "1" on channel 5 ■ Bit 6: Substitute value "1" on channel 6 ■ Bit 7: Substitute value "1" on channel 7 	00h
2	not relevant	00h
3	not relevant	00h



You should only enable the parameters in byte 0, "Hold last valid value" and "Enable substitute value" as an alternative.

Reaction to CPU-Stop

Here the module reaction at CPU-STOP may be set. There are the following possibilities:

- Keep last valid value
 - The value of each channel is frozen when the CPU is stopped
- Substitute a value
 - At CPU-STOP each channel is substituted by a value which may be assigned by byte 1.

4.7.2 Technical data

Order no.	322-5FF00
Type	SM 322
SPEED-Bus	-
Current consumption/power loss	
Current consumption from backplane bus	100 mA
Power loss	8.6 W
Technical data digital outputs	
Number of outputs	8
Cable length, shielded	1000 m
Cable length, unshielded	600 m

322-5FF00 - DO 8xAC 120/230V 2A > Technical data

Order no.	322-5FF00
Rated load voltage	AC 120/230 V
Current consumption from load voltage L+ (without load)	2 mA
Total current per group, horizontal configuration, 40°C	8 A
Total current per group, horizontal configuration, 60°C	4 A
Total current per group, vertical configuration	4 A
Output current at signal "1", rated value	2 A
Output delay of "0" to "1"	-
Output delay of "1" to "0"	-
Minimum load current	-
Lamp load	50 W
Parallel switching of outputs for redundant control of a load	possible
Parallel switching of outputs for increased power	not possible
Actuation of digital input	✓
Switching frequency with resistive load	max. 10 Hz
Switching frequency with inductive load	max. 0.5 Hz
Switching frequency on lamp load	max. 1 Hz
Internal limitation of inductive shut-off voltage	-
Short-circuit protection of output	Fuse 3.15 A /250 V, quick response
Trigger level	3.15 A
Number of operating cycle of relay outputs	-
Switching capacity of contacts	-
Output data size	1 Byte
Status information, alarms, diagnostics	
Status display	green LED per channel
Interrupts	no
Process alarm	no
Diagnostic interrupt	no
Diagnostic functions	no
Diagnostics information read-out	none
Supply voltage display	none
Group error display	red SF LED
Channel error display	none
Isolation	
Between channels	✓
Between channels of groups to	1
Between channels and backplane bus	✓

Order no.	322-5FF00
Insulation tested with	AC 1500 V
Datasizes	
Input bytes	0
Output bytes	1
Parameter bytes	21
Diagnostic bytes	0
Housing	
Material	PPE
Mounting	Rail System 300
Mechanical data	
Dimensions (WxHxD)	40 mm x 125 mm x 120 mm
Weight	330 g
Environmental conditions	
Operating temperature	0 °C to 60 °C
Storage temperature	-25 °C to 70 °C
Certifications	
UL certification	yes
KC certification	yes

4.8 322-1HH00 - DO 16xRelay

Properties

The relay output module collects the binary control signals from the superordinate bus system and transmits them via relay outputs to the process level. The module electronics are provided via the back panel bus. It has 16 channels working as switches, and their status is monitored via LEDs.

- 16 relay outputs in groups of 8
- Power supply via back panel bus
- Load capacity voltage AC 230V / DC 30V
- Maximal contact rating per channel 5A
- useable for small motors, lamps, magnetic valve and DC contactors
- Activity LED per channel

Structure

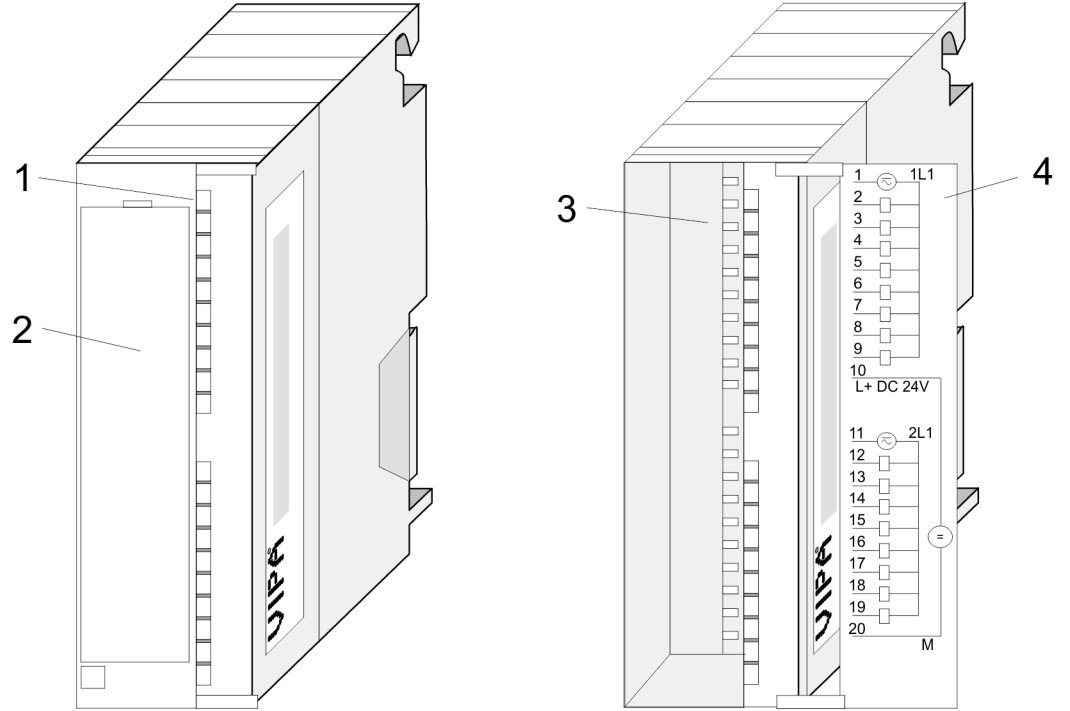

- 1 LEDs
- 2 flap with labeling strip
- 3 contact bar
- 4 flap opened with inner label

Pin assignment Circuit diagram Status monitor

Pin	Assignment	Circuit diagram	LED	Description	
1	1L1		.0	LED (green)	
2	Relay-Output Q+0.0		...	Q+0.0 to Q+1.7	
3	...				
4	...				
9	Relay-Output Q+0.7			.7	As soon as an output is active, the according LED is turned on
10	L+DC 24V				
11	2L1				
12	Relay-Output Q+1.0				
13	...				
14	...				
15	...				
16	...				
17	...				
18	...				
19	Relay-Output Q+1.7				
20	Ground				

Schematic diagram

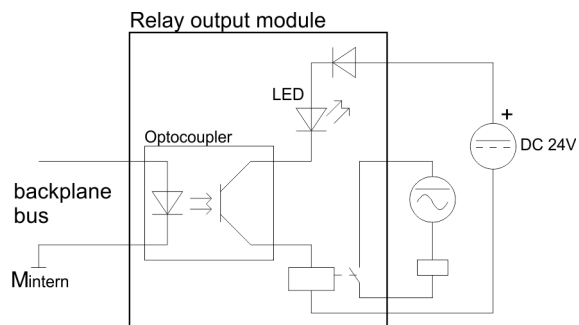

When using inductive load please take an suitable protector!

Maximum toggle capacity

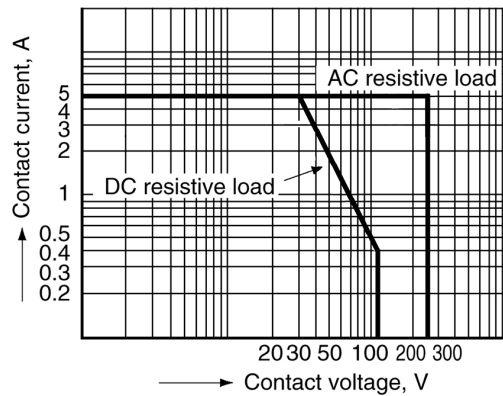

Life Time

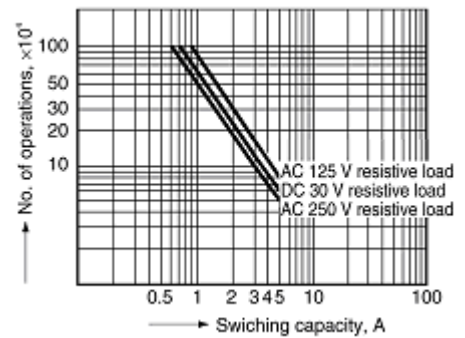

4.8.1 Technical data

Order no.	322-1HH00
Type	SM 322
SPEED-Bus	-
Current consumption/power loss	
Current consumption from backplane bus	80 mA
Power loss	4 W
Technical data digital outputs	
Number of outputs	16
Cable length, shielded	1000 m
Cable length, unshielded	600 m
Rated load voltage	DC 30 V/ AC 230 V
Current consumption from load voltage L+ (without load)	-
Total current per group, horizontal configuration, 40°C	8 A
Total current per group, horizontal configuration, 60°C	8 A
Total current per group, vertical configuration	8 A
Output current at signal "1", rated value	5 A
Output delay of "0" to "1"	10 ms
Output delay of "1" to "0"	5 ms
Minimum load current	-
Lamp load	6 W
Parallel switching of outputs for redundant control of a load	not possible
Parallel switching of outputs for increased power	not possible
Actuation of digital input	✓
Switching frequency with resistive load	max. 0.33 Hz
Switching frequency with inductive load	max. 0.33 Hz

Order no.	322-1HH00
Switching frequency on lamp load	max. 0.33 Hz
Internal limitation of inductive shut-off voltage	-
Short-circuit protection of output	-
Trigger level	-
Number of operating cycle of relay outputs	-
Switching capacity of contacts	5 A
Output data size	2 Byte
Status information, alarms, diagnostics	
Status display	green LED per channel
Interrupts	no
Process alarm	no
Diagnostic interrupt	no
Diagnostic functions	no
Diagnostics information read-out	none
Supply voltage display	none
Group error display	none
Channel error display	none
Isolation	
Between channels	✓
Between channels of groups to	8
Between channels and backplane bus	✓
Insulation tested with	AC 1500 V
Datasizes	
Input bytes	0
Output bytes	2
Parameter bytes	0
Diagnostic bytes	0
Housing	
Material	PPE
Mounting	Rail System 300
Mechanical data	
Dimensions (WxHxD)	40 mm x 125 mm x 120 mm
Weight	290 g
Environmental conditions	
Operating temperature	0 °C to 60 °C
Storage temperature	-25 °C to 70 °C

322-1HH00 - DO 16xRelay > Technical data

Order no.	322-1HH00
Certifications	
UL certification	yes
KC certification	yes

5 Digital Input/Output Modules

5.1 323-1BH00 - DIO 16xDC 24V 1A

Properties

The module is a combined module. It has 16 channels that can be used either as inputs or outputs. Every channel supports a diagnostic function, i.e. as soon as an output is active, the according input is set. If there is a short circuit at the load, the according input is reset and the error may be recognized by analyzing the input.

- 16 channels, isolated to the backplane bus (as input or output)
- Diagnostic function
- Nominal input voltage DC 24V / supply voltage DC 24V
- Output current 1A
- LED for error message at overload, overheat or short circuit
- Activity monitoring of the channels via LED

Structure

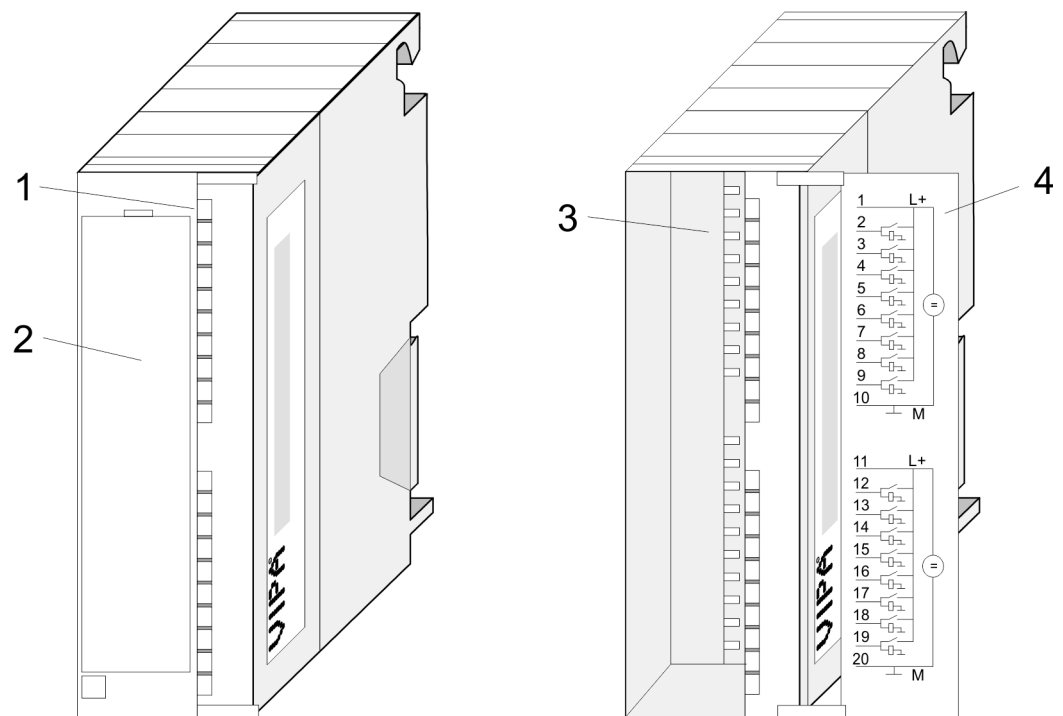

- 1 LEDs
- 2 flap with labeling strip
- 3 contact bar
- 4 flap opened with inner label



CAUTION!

Please regard that the voltage applied to an output channel must be \leq the voltage supply applied to L+. Due to the parallel connection of in- and output channel per group, a set output channel may be supplied via an applied input signal. Thus, a set output remains active even at power-off of the voltage supply with the applied input signal. Non-observance may cause module demolition.

323-1BH00 - DIO 16xDC 24V 1A

Pin assignment Circuit diagram Status monitor

Pin	Assignment	Circuit diagram	LED	Description			
1	Supply voltage +DC 24V (1L+)		1L+, 2L+	LED (green) supply voltage is on			
2	In-/Output I/Q+0.0						
...	...						
9	In-/Output I/Q+0.7						
10	Ground 1						
11	Supply voltage +DC 24V (2L+)					.07	LED (green) per Byte As soon as an input signal "1" or an active output is recognized, the according LED is activated
12	In-/Output I/Q+1.0						
...	...						
19	In-/Output I/Q+1.7						
20	Ground 2						

Schematic diagram

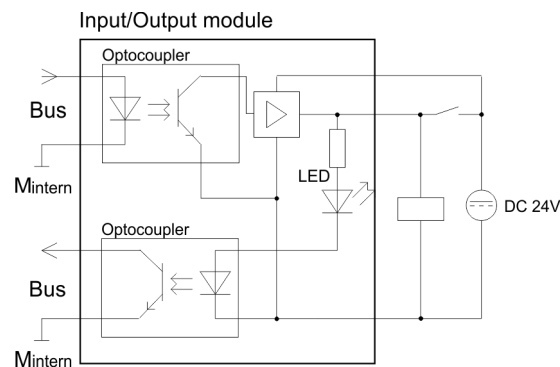

Project Engineering

Project Engineering as 323-1BL00!

5.1.1 Technical data

Order no.	323-1BH00
Type	SM 323
SPEED-Bus	-
Current consumption/power loss	
Current consumption from backplane bus	130 mA
Power loss	4 W
Technical data digital inputs	
Number of inputs	16
Cable length, shielded	1000 m
Cable length, unshielded	600 m
Rated load voltage	DC 24 V
Current consumption from load voltage L+ (without load)	30 mA
Rated value	DC 20.4...28.8 V
Input voltage for signal "0"	DC 0...5 V
Input voltage for signal "1"	DC 15...28.8 V
Input voltage hysteresis	-
Frequency range	-
Input resistance	-
Input current for signal "1"	7 mA
Connection of Two-Wire-BEROs possible	✓
Max. permissible BERO quiescent current	1.5 mA
Input delay of "0" to "1"	3 ms
Input delay of "1" to "0"	3 ms
Number of simultaneously utilizable inputs horizontal configuration	16
Number of simultaneously utilizable inputs vertical configuration	16
Input characteristic curve	IEC 61131-2, type 1
Initial data size	2 Byte
Technical data digital outputs	
Number of outputs	16
Cable length, shielded	1000 m
Cable length, unshielded	600 m
Rated load voltage	DC 24 V
Reverse polarity protection of rated load voltage	✓
Current consumption from load voltage L+ (without load)	30 mA
Output current at signal "1", rated value	1 A

Order no.	323-1BH00
Output delay of "0" to "1"	150 µs
Output delay of "1" to "0"	100 µs
Minimum load current	-
Lamp load	5 W
Parallel switching of outputs for redundant control of a load	possible (only outputs group)
Parallel switching of outputs for increased power	not possible
Actuation of digital input	✓
Switching frequency with resistive load	max. 1000 Hz
Switching frequency with inductive load	max. 0.5 Hz
Switching frequency on lamp load	max. 10 Hz
Internal limitation of inductive shut-off voltage	L+ (-52 V)
Short-circuit protection of output	yes, electronic
Trigger level	1.5 A
Number of operating cycle of relay outputs	-
Switching capacity of contacts	-
Output data size	2 Byte
Status information, alarms, diagnostics	
Status display	green LED per channel
Interrupts	no
Process alarm	no
Diagnostic interrupt	no
Diagnostic functions	no
Diagnostics information read-out	none
Supply voltage display	green LED per group
Group error display	red SF LED
Channel error display	none
Isolation	
Between channels	✓
Between channels of groups to	8
Between channels and backplane bus	✓
Insulation tested with	DC 500 V
Datasizes	
Input bytes	2
Output bytes	2
Parameter bytes	0
Diagnostic bytes	0

Order no.	323-1BH00
Housing	
Material	PPE
Mounting	Rail System 300
Mechanical data	
Dimensions (WxHxD)	40 mm x 125 mm x 120 mm
Weight	230 g
Environmental conditions	
Operating temperature	0 °C to 60 °C
Storage temperature	-25 °C to 70 °C
Certifications	
UL certification	yes
KC certification	yes

5.2 323-1BH01 - DI 8xDC 24V, DO 8xDC 24V 1A

Properties

The module has 16 channels, isolated to the back panel bus, where 8 working as inputs and the 8 working as outputs. The status of the channels is shown via LEDs.

- 16 channels, from this 8 inputs and 8 outputs
- Nominal input voltage DC 24V
- Supply voltage DC 24V (external) for outputs
- Output current 1A per channel
- LED for error message at overload, overheat or short circuit
- Activity monitoring of the channels via LED

Structure

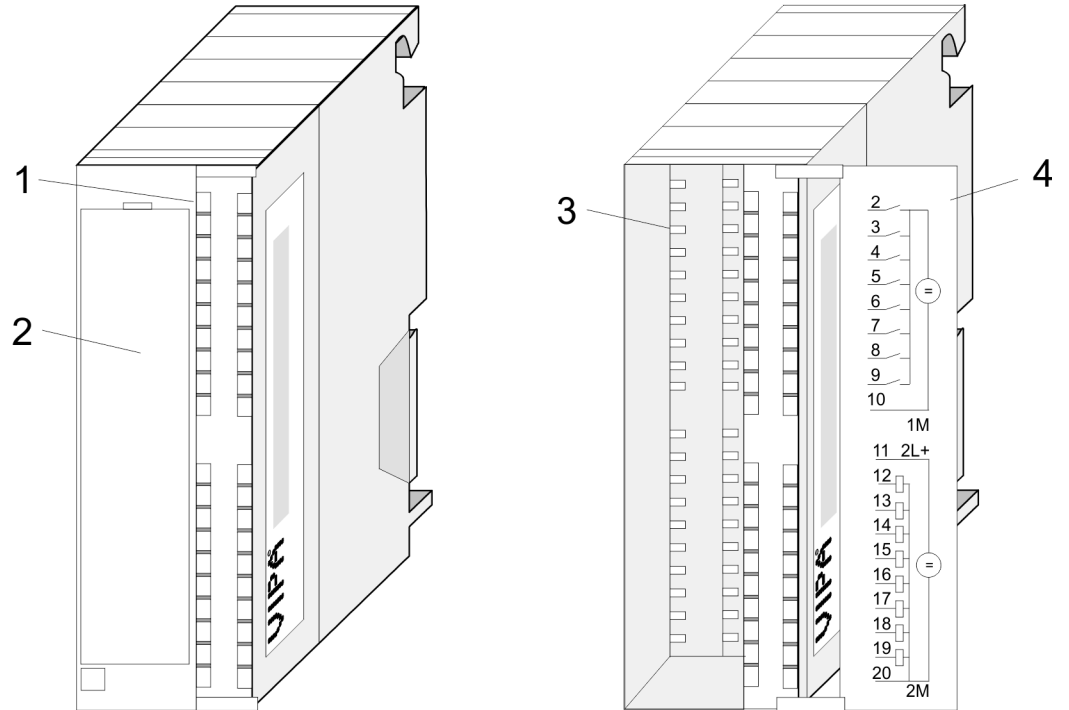

- 1 LEDs
- 2 flap with labeling strip
- 3 contact bar
- 4 flap opened with inner label



CAUTION!

Please regard that the voltage applied to an output channel must be \leq the voltage supply applied to L+. Due to the parallel connection of in- and output channel per group, a set output channel may be supplied via an applied input signal. Thus, a set output remains active even at power-off of the voltage supply with the applied input signal. Non-observance may cause module demolition.

Pin assignment Circuit diagram Status monitor

Pin	Assignment	Circuit diagram	LED	Description	
1	Not used		L+	LED (green) supply voltage is on	
2	Input I+0.0			.0	LED (green) I+0.0 ... I+0.7
...
9	Input I+0.7			.7	Q+0.0 ... Q+0.7 At signal "1" (input) res. active output, the according LED is acti- vated
10	Ground 1M inputs			F	LED (red) error at overload, short circuit
11	Supply voltage DC +24V (2L+)				
12	Output Q+0.0				
...	...				
19	Output Q+0.7				
20	Ground 2M outputs				

Schematic diagram

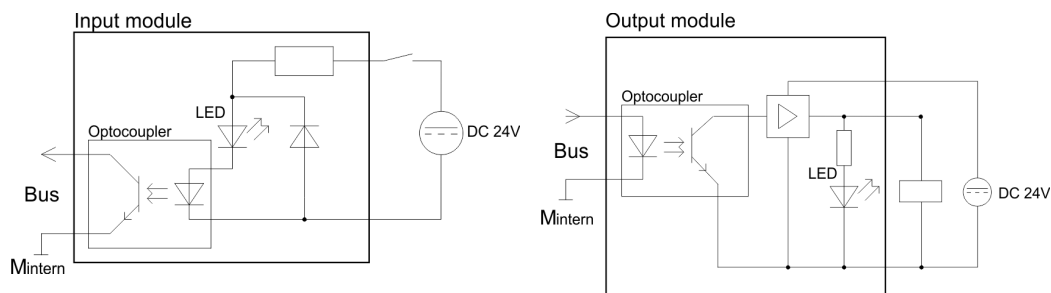

5.2.1 Technical data

Order no.	323-1BH01
Type	SM 323
SPEED-Bus	-
Current consumption/power loss	
Current consumption from backplane bus	70 mA
Power loss	4 W
Technical data digital inputs	

323-1BH01 - DI 8xDC 24V, DO 8xDC 24V 1A > Technical data

Order no.	323-1BH01
Number of inputs	8
Cable length, shielded	1000 m
Cable length, unshielded	600 m
Rated load voltage	DC 24 V
Current consumption from load voltage L+ (without load)	15 mA
Rated value	DC 20.4...28.8 V
Input voltage for signal "0"	DC 0...5 V
Input voltage for signal "1"	DC 15...28.8 V
Input voltage hysteresis	-
Frequency range	-
Input resistance	-
Input current for signal "1"	7 mA
Connection of Two-Wire-BEROs possible	✓
Max. permissible BERO quiescent current	1.5 mA
Input delay of "0" to "1"	3 ms
Input delay of "1" to "0"	3 ms
Number of simultaneously utilizable inputs horizontal configuration	8
Number of simultaneously utilizable inputs vertical configuration	8
Input characteristic curve	IEC 61131-2, type 1
Initial data size	1 Byte
Technical data digital outputs	
Number of outputs	8
Cable length, shielded	1000 m
Cable length, unshielded	600 m
Rated load voltage	DC 24 V
Reverse polarity protection of rated load voltage	✓
Current consumption from load voltage L+ (without load)	15 mA
Output current at signal "1", rated value	1 A
Output delay of "0" to "1"	150 µs
Output delay of "1" to "0"	100 µs
Minimum load current	-
Lamp load	5 W
Parallel switching of outputs for redundant control of a load	possible (only outputs group)
Parallel switching of outputs for increased power	not possible
Actuation of digital input	✓

Order no.	323-1BH01
Switching frequency with resistive load	max. 1000 Hz
Switching frequency with inductive load	max. 0.5 Hz
Switching frequency on lamp load	max. 10 Hz
Internal limitation of inductive shut-off voltage	L+ (-52 V)
Short-circuit protection of output	yes, electronic
Trigger level	1.5 A
Number of operating cycle of relay outputs	-
Switching capacity of contacts	-
Output data size	1 Byte
Status information, alarms, diagnostics	
Status display	green LED per channel
Interrupts	no
Process alarm	no
Diagnostic interrupt	no
Diagnostic functions	no
Diagnostics information read-out	none
Supply voltage display	green LED per group
Group error display	red SF LED
Channel error display	none
Isolation	
Between channels	✓
Between channels of groups to	8
Between channels and backplane bus	✓
Insulation tested with	DC 500 V
Datasizes	
Input bytes	1
Output bytes	1
Parameter bytes	0
Diagnostic bytes	0
Housing	
Material	PPE
Mounting	Rail System 300
Mechanical data	
Dimensions (WxHxD)	40 mm x 125 mm x 120 mm
Weight	240 g
Environmental conditions	

323-1BL00 - DI 16xDC 24V, DO 16xDC 24V 1A

Order no.	323-1BH01
Operating temperature	0 °C to 60 °C
Storage temperature	-25 °C to 70 °C
Certifications	
UL certification	yes
KC certification	yes

5.3 323-1BL00 - DI 16xDC 24V, DO 16xDC 24V 1A

Properties

The module has 32 channels, isolated to the back plane bus, with 16 inputs and 16 outputs. The status of the channels is shown via LEDs.

- 32 channels, 16 inputs and 16 outputs
- Nominal input voltage DC 24V
- Supply voltage DC 24V (external) for outputs
- Output current 1A per channel
- LED for error message at overload, overheat or short circuit
- Activity monitoring of the channels via LED
- Starting from hardware version 5 *safe shutdown* is supported. ↪ Chapter 4.1 'Safe shutdown of non-safe outputs' on page 35

Structure

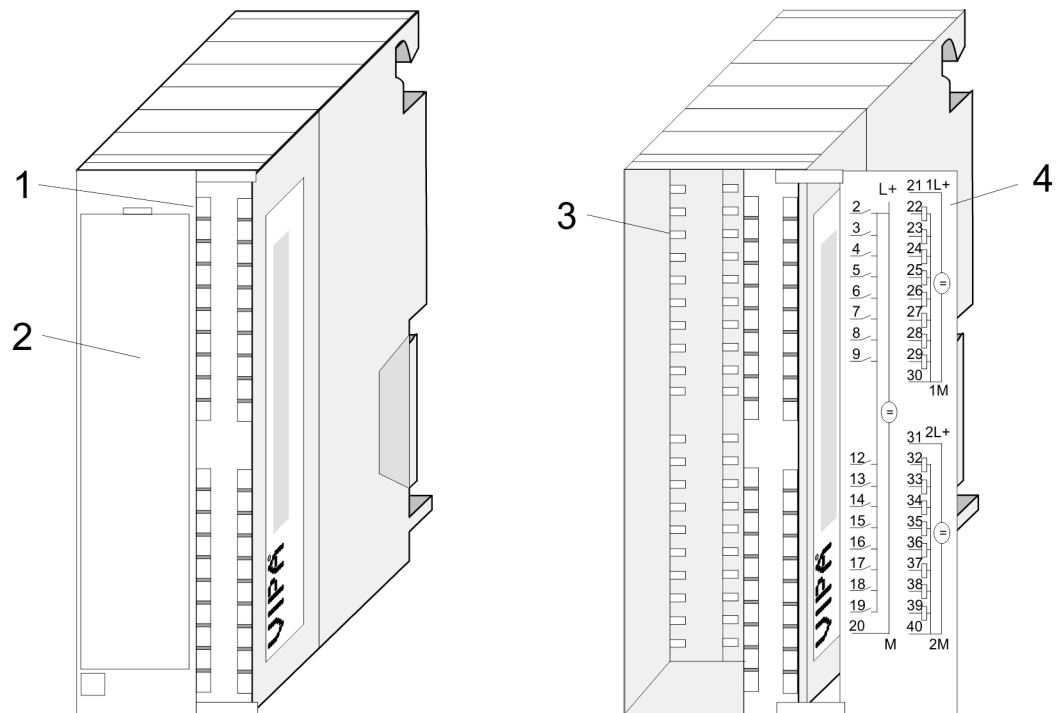

- 1 LEDs
- 2 flap with labeling strip
- 3 contact bar
- 4 flap opened with inner label



CAUTION!

Please regard that the voltage applied to an output channel must be \leq the voltage supply applied to L+. Due to the parallel connection of in- and output channel per group, a set output channel may be supplied via an applied input signal. Thus, a set output remains active even at power-off of the voltage supply with the applied input signal. Non-observance may cause module demolition.

Pin assignment Circuit diagram Status monitor

Pin	Assignment	Circuit diagram	LED	Description		
1	Not used		1L+, 2L+	LED (green) supply voltage is on		
2	Input I+0.0			.07	LED (green) I+0.0 ... I+1.7 Q+0.0 ... Q+1.7 At signal "1" (input) res. active output, the according LED is acti- vated	
...	...			F	LED (red) error at overload, short circuit	
19	Input I+1.7			31 2L+		
20	Ground 1M inputs			12 32 13 33 14 34		
21, 31	Supply voltage DC +24V			15 35 16 36		
22	Output Q+0.0			17 37 18 38 19 39		
...	...			20 40		
39	Output Q+1.7					
30	Ground 2M outputs					
40	Ground 3M outputs					

Schematic diagram

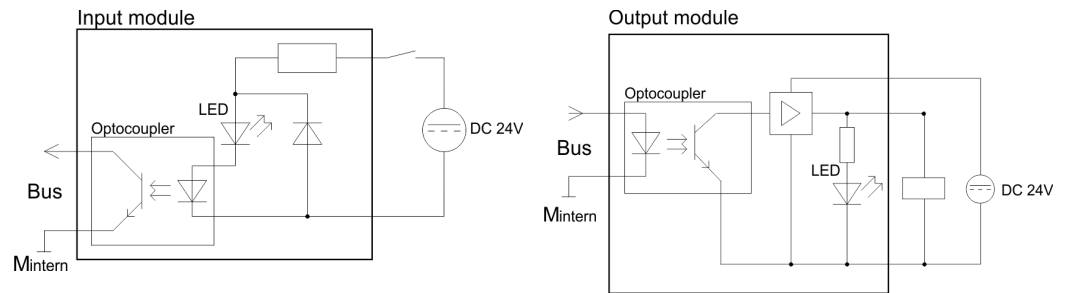

5.3.1 Technical data

Order no.	323-1BL00
Type	SM 323
SPEED-Bus	-
Current consumption/power loss	
Current consumption from backplane bus	130 mA
Power loss	5.8 W
Technical data digital inputs	
Number of inputs	16
Cable length, shielded	1000 m
Cable length, unshielded	600 m
Rated load voltage	DC 24 V
Current consumption from load voltage L+ (without load)	30 mA
Rated value	DC 20.4...28.8 V
Input voltage for signal "0"	DC 0...5 V
Input voltage for signal "1"	DC 15...28.8 V
Input voltage hysteresis	-
Frequency range	-
Input resistance	-
Input current for signal "1"	7 mA
Connection of Two-Wire-BEROs possible	✓
Max. permissible BERO quiescent current	1.5 mA
Input delay of "0" to "1"	3 ms
Input delay of "1" to "0"	3 ms
Number of simultaneously utilizable inputs horizontal configuration	16
Number of simultaneously utilizable inputs vertical configuration	16
Input characteristic curve	IEC 61131-2, type 1
Initial data size	2 Byte

Order no.	323-1BL00
Technical data digital outputs	
Number of outputs	16
Cable length, shielded	1000 m
Cable length, unshielded	600 m
Rated load voltage	DC 24 V
Reverse polarity protection of rated load voltage	✓
Current consumption from load voltage L+ (without load)	30 mA
Output current at signal "1", rated value	1 A
Output delay of "0" to "1"	150 µs
Output delay of "1" to "0"	100 µs
Minimum load current	-
Lamp load	5 W
Parallel switching of outputs for redundant control of a load	possible (only outputs group)
Parallel switching of outputs for increased power	not possible
Actuation of digital input	✓
Switching frequency with resistive load	max. 1000 Hz
Switching frequency with inductive load	max. 0.5 Hz
Switching frequency on lamp load	max. 10 Hz
Internal limitation of inductive shut-off voltage	L+ (-52 V)
Short-circuit protection of output	yes, electronic
Trigger level	1.5 A
Number of operating cycle of relay outputs	-
Switching capacity of contacts	-
Output data size	2 Byte
Status information, alarms, diagnostics	
Status display	green LED per channel
Interrupts	no
Process alarm	no
Diagnostic interrupt	no
Diagnostic functions	no
Diagnostics information read-out	none
Supply voltage display	green LED per group
Group error display	red SF LED
Channel error display	none
Isolation	
Between channels	✓

323-1BL00 - DI 16xDC 24V, DO 16xDC 24V 1A > Technical data

Order no.	323-1BL00
Between channels of groups to	8
Between channels and backplane bus	✓
Insulation tested with	DC 500 V
Datasizes	
Input bytes	2
Output bytes	2
Parameter bytes	0
Diagnostic bytes	0
Housing	
Material	PPE
Mounting	Rail System 300
Mechanical data	
Dimensions (WxHxD)	40 mm x 125 mm x 120 mm
Weight	260 g
Environmental conditions	
Operating temperature	0 °C to 60 °C
Storage temperature	-25 °C to 70 °C
Certifications	
UL certification	yes
KC certification	yes

6 Digital Modules FAST - SPEED-Bus

6.1 Addressing at SPEED-Bus

Overview

To provide specific addressing of the installed peripheral modules, certain addresses must be allocated in the CPU. With no hardware configuration present, the CPU assigns automatically peripheral I/O addresses during boot procedure depending on the plug-in location amongst others also for plugged modules at the SPEED-Bus.

Maximal pluggable modules

In the hardware configurator from Siemens up to 8 modules per row may be parameterized. At deployment of SPEED7 CPUs up to 32 modules at the standard bus and 10 further modules at the SPEED-Bus may be controlled. CPs and DP masters that are additionally virtual configured at the standard bus are taken into the sum of 32 modules at the standard bus. For the project engineering of more than 8 modules you may use virtual line interface connections. For this you set in the hardware configurator the module IM 360 from the hardware catalog to slot 3 of your 1. profile rail. Now you may extend your system with up to 3 profile rails by starting each with an IM 361 from Siemens at slot 3.

Define addresses by hardware configuration

You may access the modules with read res. write accesses to the peripheral bytes or the process image. To define addresses, a hardware configuration via a virtual PROFIBUS system by including the SPEEDBUS.GSD may be used. For this, click on the properties of the according module and set the wanted address.

Automatic addressing

If you do not like to use a hardware configuration, an automatic addressing comes into force. At the automatic address allocation DIOs are mapped depending on the slot location with a distance of 4byte and AIOs, FMs, CPs with a distance of 256byte. Depending on the slot location the start address from where on the according module is stored in the address range is calculated with the following formulas:

DIOs: Start address = $4 \times (\text{slot} - 101) + 128$

AIOs, FMs, CPs: Start address = $256 \times (\text{slot} - 101) + 2048$

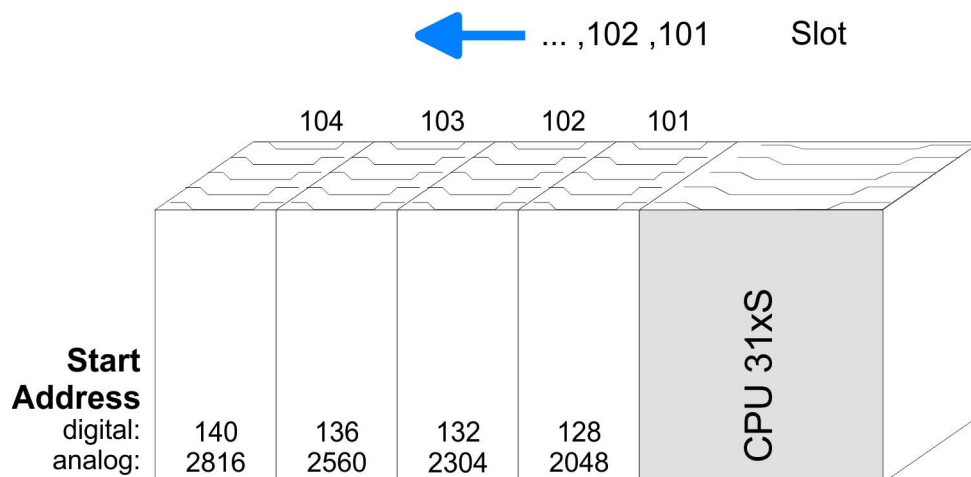

6.2 Project engineering

Overview

Every module at the SPEED-Bus including the CPU has to be configured as single "VIPA_SPEEDbus"-DP slave at a virtual DP master (342-5DA02 V5.0 from Siemens). For this you have to include the GSD speedbus.gsd. Every "VIPA_SPEEDbus"-DP slave has exactly one slot for the project engineering where you must place the according SPEED-Bus module. The assignment of a SPEED-Bus slave to a SPEED-Bus slot number takes place via the PROFIBUS address starting with 100.

6.2.1 Fast introduction

For the employment of the I/O modules at the SPEED-Bus the inclusion via the GSD-file from VIPA in the hardware catalog is required.

To be compatible with the Siemens SIMATIC manager, you have to execute the following steps:

1. Start the hardware configurator from Siemens and include the speedbus.gsd for SPEED7 from VIPA.
2. Configure the corresponding Siemens CPU.
3. Starting with slot 4, place the System 300 modules in the plugged sequence.
4. Project engineering and connection of the SPEED-Bus-CPs res. -DP master at the standard bus as virtual CP 343-1 (343-1EX11) res. CP 342-5 (342-5DA02 V5.0)
5. For the SPEED-Bus you always include, connect and parameterize to the *operating mode* DP master the DP master CP 342-5 (342-5DA02 V5.0) as last module. To this master system you assign every SPEED-Bus module as VIPA_SPEEDbus slave. Here the PROFIBUS address corresponds to the slot number beginning with 100 for the CPU. Place at slot 0 of every slave the assigned module and alter the parameters if needed.

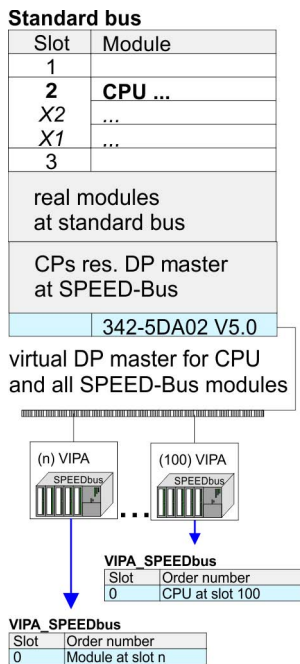

6.2.2 Preconditions

The hardware configurator is part of the Siemens SIMATIC manager. It serves for project engineering. The modules that may be configured here are listed in the hardware catalog. For the employment of the System 300S modules at the SPEED-Bus you have to include the System 300S modules into the hardware catalog via the GSD-file speedbus.gsd from VIPA.



For the project engineering, a thorough knowledge of the Siemens SIMATIC manager and the hardware configurator from Siemens is required!

Installation of the SPEEDBUS.GSD

The GSD (Geräte-Stamm-Datei) is online available in the following language versions. Further language versions are available on inquire:

Name	Language
SPEEDBUS.GSD	German (default)
SPEEDBUS.GSG	German
SPEEDBUS.GSE	English

The GSD files may be found at www.vipa.com at the "Service" part.

The integration of the SPEEDBUS.GSD takes place with the following proceeding:

1. Browse to www.vipa.com
2. Click to 'Service → Download → GSD- and EDS-Files → Profibus'
3. Download the file Cx000023_Vxxx.
4. Extract the file to your work directory. The SPEEDBUS.GSD is stored in the directory VIPA_System_300S.
5. Start the hardware configurator from Siemens.
6. Close every project.
7. Select 'Options → Install new GSD-file'.
8. Navigate to the directory VIPA_System_300S and select **SPEEDBUS.GSD** an.
 - ⇒ The SPEED7 CPUs and modules of the System 300S from VIPA may now be found in the hardware catalog at PROFIBUS-DP / Additional field devices / I/O / VIPA_SPEEDBUS.

6.2.3 Steps of project engineering

The following text describes the approach of the project engineering in the hardware configurator from Siemens at an abstract sample.

The project engineering is separated into following parts:

- Project engineering of the modules at the standard bus
- Project engineering of the SPEED-Bus modules in a virtual master system (speedbus.gsd required)

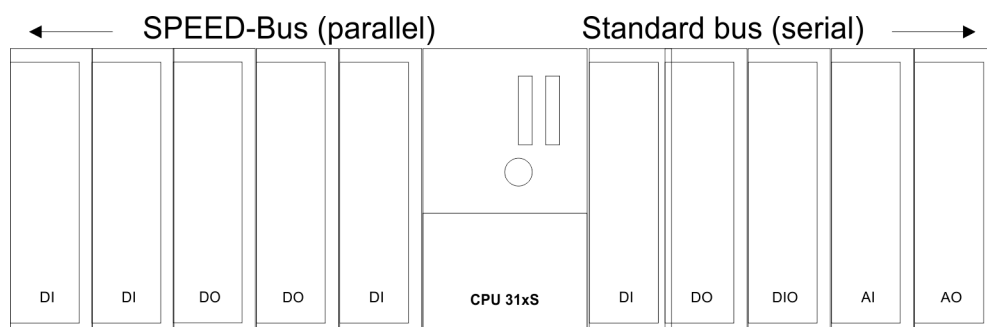
**Preconditions**

For the employment of the System 300S modules at the SPEED-Bus you have to include the System 300S modules into the hardware catalog via the GSD-file speedbus.gsd from VIPA.

Project engineering of the modules at the standard bus

The modules at the right side of the CPU at the standard bus are configured with the following approach:

1. ➤ Start the hardware configurator from Siemens with a new project and insert a profile rail from the hardware catalog.
2. ➤ Place the corresponding Siemens CPU at slot 2.
3. ➤ Include your System 300V modules at the standard bus in the plugged sequence starting with slot 4.
4. ➤ Parameterize the CPU res. the modules where appropriate. The parameter window opens by a double click on the according module.
5. ➤ To extend the bus you may use the IM 360 from Siemens where you can connect up to 3 further extension racks via the IM 361. Bus extensions are always placed at slot 3.
6. ➤ Save your project.

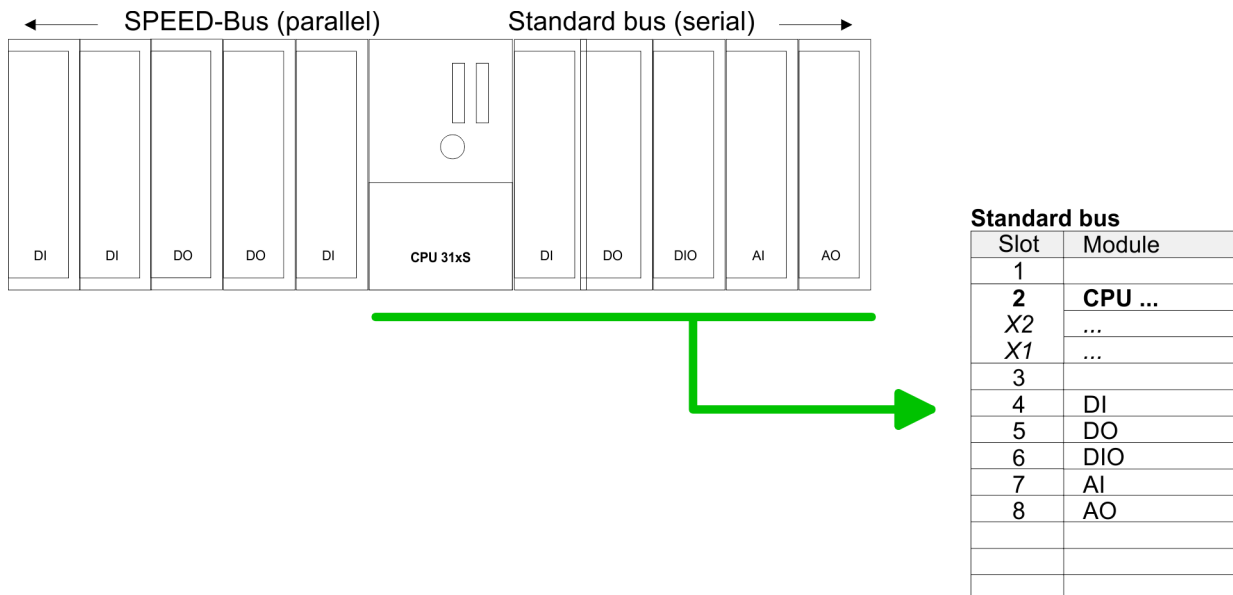

i To extend the bus you may use the IM 360 from Siemens where you can connect up to 3 further extension racks via the IM 361. Bus extensions are always placed at slot 3.

Project engineering of all SPEED-Bus modules in a virtual master system

The slot assignment of the SPEED-Bus modules and the parameterization of the in-/output periphery happens via a virtual PROFIBUS DP master system. For this, place as last module a DP master (342-5DA02 V5.0) with master system. For the employment of the System 300S modules at the SPEED-Bus the inclusion of the System 300S modules into the hardware catalog via the GSD-file speedbus.gsd from VIPA is required.

After the installation of the speedbus.gsd you may locate under *Profibus DP / Additional field devices / I/O / VIPA_SPEEDbus* the DP slave system vipa_speedbus.

Now include for the CPU and every module at the SPEED-Bus a slave system "vipa_speedbus". Set as PROFIBUS address the slot number (100...110) of the module and place the according module from the hardware catalog of VIPA_speedbus to slot 0 of the slave system.

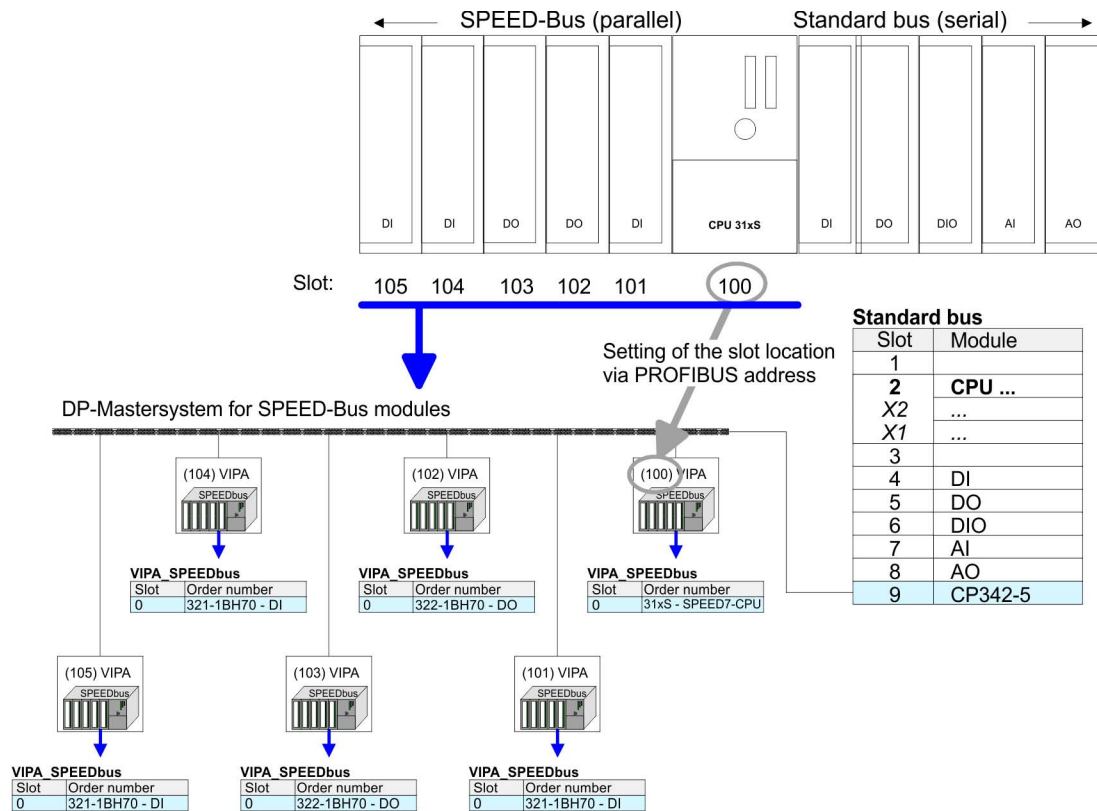

The according module is to be taken over from the HW Catalog of vipa_speedbus to slot 0.

6.3 321-1BH70 - DI 16xDC 24V

Properties

The fast digital input module collects the binary control signals from the process level and transmits them galvanically separated to the superordinate bus system. It has 16 channels and their status is monitored via LEDs.

- 16 fast input channels, isolated to SPEED-Bus
- Extended parameterization possibility
- Nominal input voltage DC 24V
- Useable for switches and approximate switches
- Status monitoring of the channels via LEDs

321-1BH70 - DI 16xDC 24V

Construction

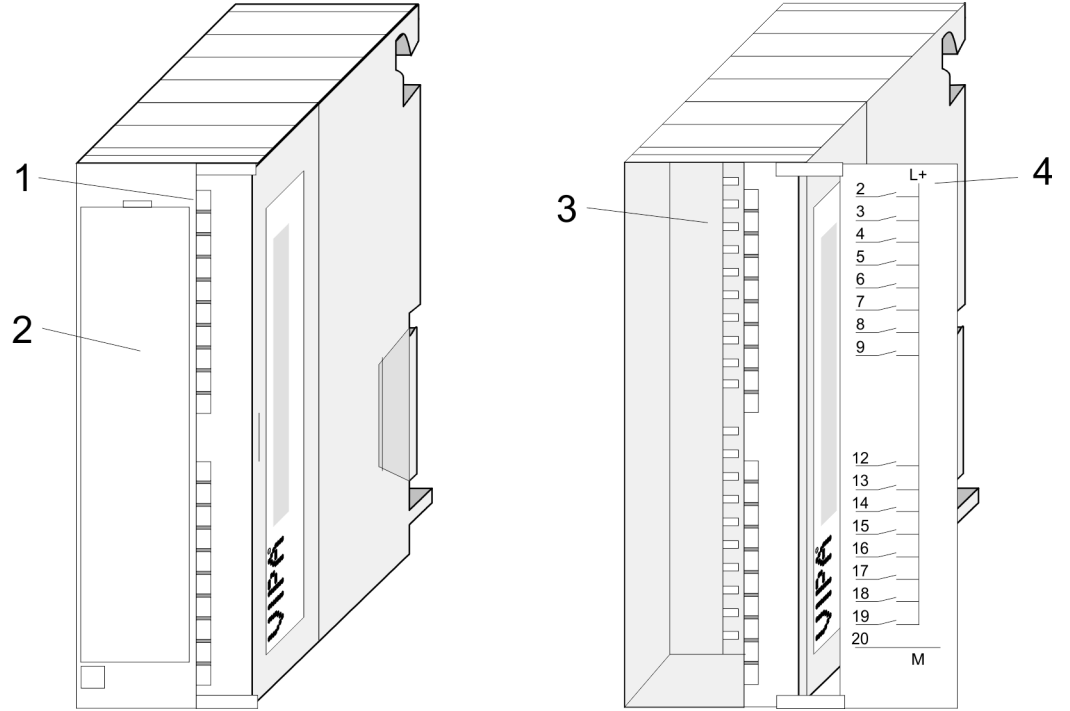

- 1 LEDs
- 2 flap with labeling strip
- 3 contact bar
- 4 flap opened with inner label

Pin assignment Circuit diagram Status monitor

Pin	Assignment	Circuit diagram	LED	Description	
1	DC 24V		.0	LEDs (green)	
2	Input I+0.0		...	I+0.0 to I+1.7	
.	.			.7	from ca. 15V on, the signal is recognized as "1" and the according LED is addressed
.	.				
9	Input I+0.7				
10	not used				
11	not used				
12	Input I+1.0				
.	.				
.	.				
19	Input I+1.7				
20	Ground				
.	.				
.	.				

Schematic diagram

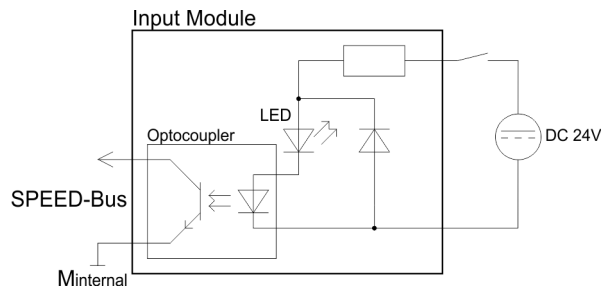

6.3.1 Parameterization

Depending on the project engineering, 2byte res. 48byte in the input range of the CPU where occupied by the module. For project engineering there are the following possibilities:

- Project engineering as *321-1BH70 DI16xDC24V*
 - Range in PII: 2byte
 - Parameter: none
 - Input filter time delay: 2.56µs
- Project engineering as *DI16 Alarm/ETS*
 - Range in PII: 48byte
 - Parameter: 66byte (edge selection, time stamp, filter)
 - Input filter time delay: 1µs + parameter filter value

6.3.1.1 Project engineering as 321-1BH70 DI16xDC24V

At this project engineering you have no parameterization options and your module occupies 2bytes in the input address range of the CPU. If no hardware project engineering is present, this operation mode is used as default. Here the module has a delay time of 2.56µs.

6.3.1.2 Project engineering as DI16 Alarm/ETS

If the module is defined as "DI16 Alarm/ETS" in the hardware configuration, it occupies 48byte of the input range of the CPU and can be parameterized with 66byte of data. The following parameters are at your disposal:

- Diagnostic interrupt (global for all inputs)
- Edge selection (switchable process interrupt per channel)
- Time stamp (activation of a time stamp function per channel)
- Filter value (for grubby input signals per channel)

Structure of the parameter data

During the parameterization, a parameter area of 66byte is transferred in the record sets 7Fh, 80h and 81h. Using the SFCs 55, 56 and 57 you may alter parameters and transfer them to the module during runtime. The record sets have the following structure:

Record set 7Fh Diagnostic interrupt

This record set activates res. de-activates the diagnostic function. A diagnostic interrupt occurs when during a process interrupt execution another process interrupt is initialized for the same event.

The record set has the following structure:

Word	
0	Bit 15 ... 0: <i>Diagnostic interrupt</i> 0000h = de-activated 0001h = activated
2	Bit 15 ... 0: <i>reserved</i>

Record set 80h Edge selection

Via this record set you may activate a process interrupt for I+0.0 ... I+1.7 and define for which edge of the input signal a process interrupt is thrown.

The record set has the following structure:

Byte	
0	<ul style="list-style-type: none"> ■ <i>Bit 1 ... 0: Edge selection I+0.0</i> <ul style="list-style-type: none"> – 00b = de-activated – 01b = Process interrupt at ascending edge – 10b = Process interrupt at descending edge – 11b = Process interrupt at both edges ■ <i>Bit 7 ... 2: reserved</i>
...	...
15	<ul style="list-style-type: none"> ■ <i>Bit 1 ... 0: Edge selection I+1.7</i> <ul style="list-style-type: none"> – 00b = de-activated – 01b = Process interrupt at ascending edge – 10b = Process interrupt at descending edge – 11b = Process interrupt both edges ■ <i>Bit 7 ... 2: reserved</i>

Record set 80h ETS time stamp (Byte 16 ... 31)

Every SPEED-Bus module carries along a timer with a resolution of 1 μ s. The timer starts at boot-up of the CPU. Thus gives you a time base with an accuracy of $\pm 1\mu$ s at the SPEED-Bus. By parameterization of the ETS function (Edge Timestamp) for an input, the current time value is entered in the process image of the module at according edge. Thus allows you to compare times of different input channels via your user application.

Via the parameter *Time stamp* you may activate the ETS system and define the edge of the input signal that initiates the process image entry of a time stamp. You have the following options:

- No time stamp
- Time stamp at ascending edge
- Time stamp at descending edge
- Time stamp at both edges

Allocation in the process image ↗ '48bytes in the process image' on page 94



The stored times correspond the point in time when the signal has already passed the input filter of the module. To calculate the real time at the clamp, you have to subtract the delay time of 1 μ s and the parameterized delay time defined under Filter.

Byte	Bit 7 ... Bit 0
16	<ul style="list-style-type: none"> ■ Bit 1, 0: Time stamp channel 0 (I+0.0) <ul style="list-style-type: none"> – 00 = no time stamp – 01 = Time stamp at ascending edge – 10 = Time stamp at descending edge – 11 = Time stamp at both edges
...	...
31	<ul style="list-style-type: none"> ■ Bit 1, 0: Time stamp channel 15 (I+1.7) <ul style="list-style-type: none"> – 00 = no time stamp – 01 = Time stamp at ascending edge – 10 = Time stamp at descending edge – 11 = Time stamp at both edges

Record set 81h Input filter

This record set allows you to preset an input filter in steps of 2.56µs steps for I+0.0 ... I+1.7. By preceding a filter you define how long an input signal must be present before it is recognized as "1" signal. With the help of filters you may e.g. filter signal peaks at a blurred input signal.

The entry happens as a factor of 2.56µs (2.56µs ... 40ms) and is within the range 1 ... 16000.

The record set has the following structure:

Word	
0	Input filter I+0.0 in 2.56µs steps
...	...
30	Input filter I+1.7 in 2.56µs steps

48bytes in the process image

The module occupies 48byte in the input address range of the CPU that have the following meaning:

Byte	Bit 7 ... Bit 0
0	State of the channels (1 = set, 0 = not set) <ul style="list-style-type: none"> ■ Bit 0: Status I+0.0 ■ ... ■ Bit 7: Status I+0.7
1	State of the channels (1 = set, 0 = not set) <ul style="list-style-type: none"> ■ Bit 8: Status I+1.0 ■ ... ■ Bit 15: Status I+1.7
2 ... 3	reserved

Byte	Bit 7 ... Bit 0			
4	<p>1. edge evaluation (1 = edge detected, 0 = no edge detected)</p> <p>Here the last presence of an edge since the last read access to the register is stored.</p> <p>After a read access to this register (in the module) it is set back.</p> <ul style="list-style-type: none"> ■ Bit 0: Status I+0.0 ■ ... ■ Bit 7: Status I+0.7 			
5	<p>Edge evaluation</p> <ul style="list-style-type: none"> ■ Bit 0: Status I+1.0 ■ ... ■ Bit 7: Status I+1.7 			
6 ... 7	reserved			
8	<p>Edge lost (1 = edge lost, 0 = no edge lost)</p> <p>Here is noted if an edge change has been lost, i.e. if there has been more than one edge change since the last read access.</p> <ul style="list-style-type: none"> ■ Bit 0: Status I+0.0 ■ ... ■ Bit 7: Status I+0.7 			
9	<p>Edge lost</p> <ul style="list-style-type: none"> ■ Bit 0: Status I+1.0 ■ ... ■ Bit 7: Status I+1.7 			
10 ... 11	reserved			
	The following bytes contain the values of the μ s ticker for a channel at the time of an edge change. Only the lower 16bit are taken over. An overflow after 65ms has to be accordingly processed in the user application.			
Byte	+3	+2	+1	+0
12	Time stamp I+0.1		Time stamp I+0.0	
16	Time stamp I+0.3		Time stamp I+0.2	
20	Time stamp I+0.5		Time stamp I+0.4	
24	Time stamp I+0.7		Time stamp I+0.6	
28	Time stamp I+1.1		Time stamp I+1.0	
32	Time stamp I+1.3		Time stamp I+1.2	
36	Time stamp I+1.5		Time stamp I+1.4	
40	Time stamp I+1.7		Time stamp I+1.6	

Byte 44 ... 47

Byte	Bit 7 ... Bit 0
44	2. edge evaluation (1 = edge detected, 0 = no edge detected). Here the last presence of an edge since the last read access to the FA1 register is stored. After a read access to this register (in the module) the register is not reset. <ul style="list-style-type: none"> ■ Bit 0: Status I+0.0 ■ ... ■ Bit 7: Status I+0.7
45	Edge evaluation <ul style="list-style-type: none"> ■ Bit 0: Status I+1.0 ■ ... ■ Bit 7: Status I+0.7
46...47	reserved

For guarantee of consistency of a μ s ticker entry to the 1. edge evaluation (FA1) the 2. edge evaluation (FA2) serves for. The consistency is ensured only if the appropriate bit of the FA2 is "0". Since the last read access if more than one edge change took place, the corresponding bit of edge lost (FV) is set. Here the μ s ticker entry contains the time of the last edge.

Example:

	Byte	+1	+0
FA1	4	0 1 1 0 0 0 1 0	0 1 0 1 1 1 1 0
FV	8	0 0 0 0 0 0 0 0	0 0 0 0 1 0 1 0
...			
FA2	44	0 0 1 1 0 0 0 0	0 0 0 0 1 0 0 1

The consistent μ s ticker entries can be determined by logical bit operations: FA1 AND NOT FA2

Result	0 1 0 0 0 0 1 0 0 1 0 0 0 1 0 0
bit operation:	



Depending to the system, the SFC 14 (DPRD_DAT) "Read consistent data" cannot be used with this module.

6.3.2 Process interrupt

Via the edge selection you may activate a process interrupt in your parameterization and define on which edge of the input signal a process interrupt should be initialized. A process interrupt causes a call of the OB 40. Within the OB 40 you may find the logical basic address of the module that initialized the process interrupt by using the Local word 6. More detailed information about the initializing event is to find in the local double word 8.

Local double word 8 of the OB 40

The *local double word 8* of the OB 40 has the following structure:

Local byte	Bit 7 ... Bit 0
8	<ul style="list-style-type: none"> ■ Bit 0: Edge at I+0.0 ■ Bit 1: Edge at I+0.1 ■ Bit 2: Edge at I+0.2 ■ Bit 3: Edge at I+0.3 ■ Bit 4: Edge at I+0.4 ■ Bit 5: Edge at I+0.5 ■ Bit 6: Edge at I+0.6 ■ Bit 7: Edge at I+0.7
9	<ul style="list-style-type: none"> ■ Bit 0: Edge at I+1.0 ■ Bit 1: Edge at I+1.1 ■ Bit 2: Edge at I+1.2 ■ Bit 3: Edge at I+1.3 ■ Bit 4: Edge at I+1.4 ■ Bit 5: Edge at I+1.5 ■ Bit 6: Edge at I+1.6 ■ Bit 7: Edge at I+1.7
10	00h (fix)
11	00h (fix)

6.3.3 Diagnostic interrupt

Function

Via the parameterization (record set 7Fh) you may activate a global diagnostic interrupt for the module. A diagnostic interrupt occurs when during a process interrupt execution in OB 40 another process interrupt is thrown for the same event. The initialization of a diagnostic interrupt interrupts the recent process interrupt execution in OB 40 and branches in OB 82 to diagnostic interrupt processing_{incoming}. If during the diagnostic interrupt processing other events are occurring at other channels that may also cause a process res. diagnostic interrupt, these are interim stored. After the end of the diagnostic interrupt processing at first all interim stored diagnostic interrupts are processed in the sequence of their occurrence and then all process interrupts. If a channel where currently a diagnostic interrupt_{incoming} is processed res. interim stored initializes further process interrupts, these get lost. When a process interrupt for which a diagnostic interrupt_{incoming} has been released is ready, the diagnostic interrupt processing is called again as diagnostic interrupt_{outgoing}. All events of a channel between diagnostic interrupt_{incoming} and diagnostic interrupt_{outgoing} are not stored and get lost. Within this time window (1. diagnostic interrupt_{incoming} until last diagnostic interrupt_{outgoing}) the SF-LED of the CPU is on. Additionally for every diagnostic interrupt_{incoming/outgoing} an entry in the diagnostic buffer of the CPU occurs.

Example:

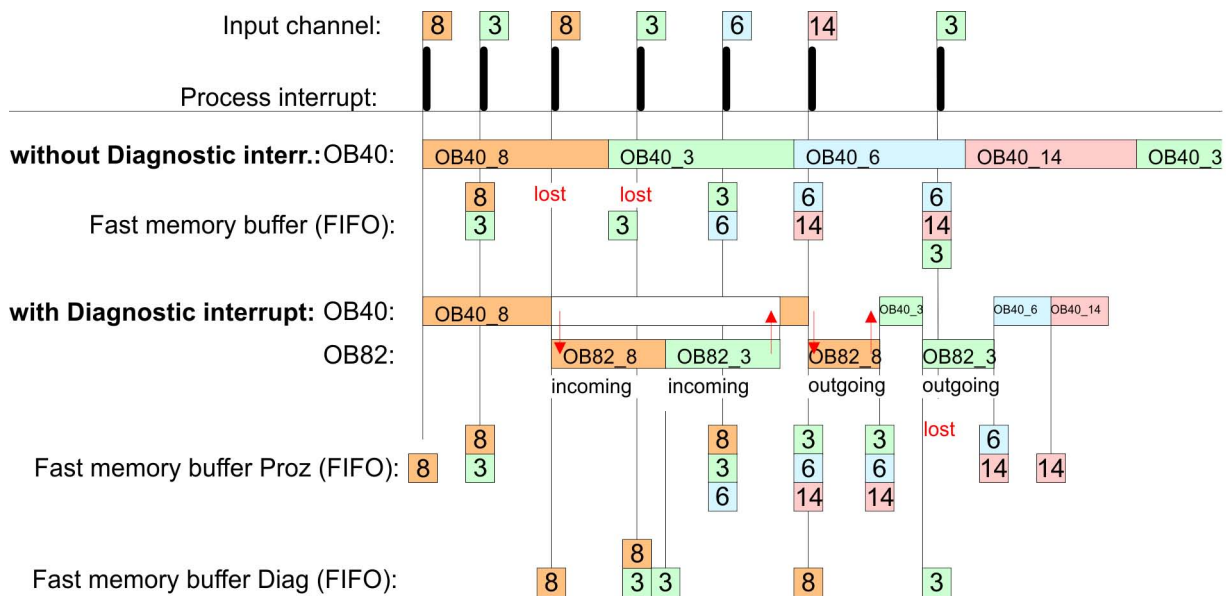

Diagnostic interrupt processing

Every OB 82 call causes an entry in the diagnostic buffer of the CPU containing error cause and module address. By using the SFC 59 you may read the diagnostic bytes. At de-activated diagnostic interrupt you have access to the last recent diagnostic event. If you've activated the diagnostic function in your hardware configuration, the contents of record set 0 are already in the local double word 8 when calling the OB 82. The SFC 59 allows you to also read the record set 1 that contains additional information. After leaving the OB 82 a clear assignment of the data to the last diagnostic interrupt is not longer possible. The record sets of the diagnostic range have the following structure:

Record set 0 Diagnostic_{incoming}

Byte	Bit 7...0
0	<ul style="list-style-type: none"> Bit 0: set at module failure Bit 1: 0 (fix) Bit 2: set at external error Bit 3: set at channel error Bit 4: set when external auxiliary supply is missing Bit 7 ... 5: 0 (fix)
1	<ul style="list-style-type: none"> Bit 3 ... 0: Module class <ul style="list-style-type: none"> 1111b: Digital Bit 4: Channel information present Bit 7 ... 5: 0 (fix)
2	00h (fix)
3	<ul style="list-style-type: none"> Bit 5 ... 0: 0 (fix) Bit 6: Process interrupt lost Bit 7: 0 (fix)

Record set 0 Diagnostic_{outgoing}

After the removing error a diagnostic message_{outgoing} takes place if the diagnostic interrupt release is still active..

Byte	Bit 7...0
0	<ul style="list-style-type: none"> ■ Bit 0: set at module failure ■ Bit 1: 0 (fix) ■ Bit 2: set at external error ■ Bit 3: set at channel error ■ Bit 4: set when external auxiliary supply is missing ■ Bit 7 ... 5: 0 (fix)
1	<ul style="list-style-type: none"> ■ Bit 3 ... 0: Module class <ul style="list-style-type: none"> – 1111b: Digital ■ Bit 4: Channel information present ■ Bit 7 ... 5: 0 (fix)
2	00h (fix)
3	00h (fix)

Diagnostic Record set 1

The record set 1 contains the 4byte of the record set 0 and additionally 12byte module specific diagnostic data. The diagnostic bytes have the following assignment:

Byte	Bit 7...0
0 ... 3	Contents record set 0 ↪ <i>'Record set 0 Diagnostic_{incoming}' on page 98</i>
4	<ul style="list-style-type: none"> ■ Bit 6 ... 0: channel type (here 70h) <ul style="list-style-type: none"> – 70h: Digital input ■ Bit 7: More channel types present <ul style="list-style-type: none"> ■ 0: no ■ 1: yes
5	Number of diagnostic bits the module puts out per channel (here 08h)
6	Number of channels of a module (here 04h)
7	<ul style="list-style-type: none"> ■ Bit 0: Error in channel group 0 (I+0.0 ... I+0.3) ■ Bit 1: Error in channel group 1 (I+0.4 ... I+0.7) ■ Bit 2: Error in channel group 2 (I+1.0 ... I+1.3) ■ Bit 3: Error in channel group 3 (I+1.4 ... I+1.7) ■ Bit 7 ... 4: 0 (fix)
8	<p>Diagnostic interrupt due to "process interrupt lost" at...</p> <ul style="list-style-type: none"> ■ Bit 0: ... input I+0.0 ■ Bit 1: 0 (fix) ■ Bit 2: ... input I+0.1 ■ Bit 3: 0 (fix) ■ Bit 4: ... input I+0.2 ■ Bit 5: 0 (fix) ■ Bit 6: ... input I+0.3 ■ Bit 7: 0 (fix)

Byte	Bit 7...0
9	Diagnostic interrupt due to "process interrupt lost" at... <ul style="list-style-type: none"> ■ Bit 0: ... input I+0.4 ■ Bit 1: 0 (fix) ■ Bit 2: ... input I+0.5 ■ Bit 3: 0 (fix) ■ Bit 4: ... input I+0.6 ■ Bit 5: 0 (fix) ■ Bit 6: ... input I+0.7 ■ Bit 7: 0 (fix)
10	Diagnostic interrupt due to "process interrupt lost" at... <ul style="list-style-type: none"> ■ Bit 0: ... input I+1.0 ■ Bit 1: 0 (fix) ■ Bit 2: ... input I+1.1 ■ Bit 3: 0 (fix) ■ Bit 4: ... input I+1.2 ■ Bit 5: 0 (fix) ■ Bit 6: ... input I+1.3 ■ Bit 7: 0 (fix)
11	Diagnostic interrupt due to "process interrupt lost" at... <ul style="list-style-type: none"> ■ Bit 0: ... input I+1.4 ■ Bit 1: 0 (fix) ■ Bit 2: ... input I+1.5 ■ Bit 3: 0 (fix) ■ Bit 4: ... input I+1.6 ■ Bit 5: 0 (fix) ■ Bit 6: ... input I+1.7 ■ Bit 7: 0 (fix)
12 ... 15	00h (fix)

6.3.4 Technical data

Order no.	321-1BH70
Type	SM 321S - SPEED-Bus
SPEED-Bus	✓
Current consumption/power loss	
Current consumption from backplane bus	390 mA
Power loss	5 W
Technical data digital inputs	
Number of inputs	16
Cable length, shielded	1000 m
Cable length, unshielded	600 m
Rated load voltage	DC 20.4...28.8 V
Current consumption from load voltage L+ (without load)	15 mA

Order no.	321-1BH70
Rated value	DC 24 V
Input voltage for signal "0"	DC 0...5 V
Input voltage for signal "1"	DC 15...28.8 V
Input voltage hysteresis	-
Frequency range	-
Input resistance	-
Input current for signal "1"	7 mA
Connection of Two-Wire-BEROs possible	✓
Max. permissible BERO quiescent current	1.5 mA
Input delay of "0" to "1"	parameterizable 2.56µs - 40ms
Input delay of "1" to "0"	parameterizable 2.56µs - 40ms
Number of simultaneously utilizable inputs horizontal configuration	16
Number of simultaneously utilizable inputs vertical configuration	16
Input characteristic curve	IEC 61131-2, type 1
Initial data size	2 Byte
Status information, alarms, diagnostics	
Status display	green LED per channel
Interrupts	yes
Process alarm	yes, parameterizable
Diagnostic interrupt	yes, parameterizable
Diagnostic functions	yes
Diagnostics information read-out	possible
Supply voltage display	green LED
Group error display	none
Channel error display	none
Isolation	
Between channels	-
Between channels of groups to	16
Between channels and backplane bus	✓
Insulation tested with	DC 500 V
Datasizes	
Input bytes	2 / 48
Output bytes	0
Parameter bytes	0 / 66
Diagnostic bytes	16

322-1BH70 - DO 16xDC 24V 0.5A

Order no.	321-1BH70
Housing	
Material	PPE
Mounting	DIN rail SPEED-Bus
Mechanical data	
Dimensions (WxHxD)	40 mm x 125 mm x 120 mm
Weight	190 g
Environmental conditions	
Operating temperature	0 °C to 60 °C
Storage temperature	-25 °C to 70 °C
Certifications	
UL certification	yes
KC certification	-

6.4 322-1BH70 - DO 16xDC 24V 0.5A

Properties

The digital fast output module collects the binary control signals from the superordinate bus system and transmits them galvanically separated to the process level. The module has to be provided with 24V via the front slot. It has 16 channels and their status is monitored via LEDs.

- 16 fast output channels, isolated to SPEED-Bus
- Supply voltage DC 24V
- Output voltage 0.5A
- Useable for magnetic valve and DC contactor
- Status monitoring of the channels via LED

Structure

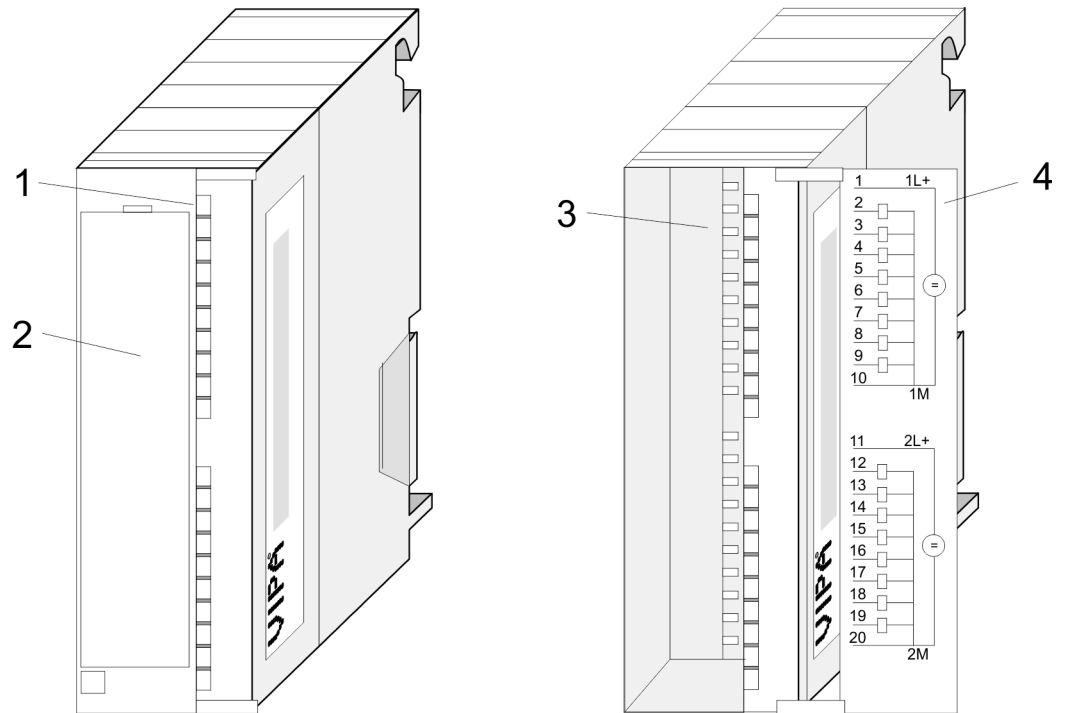

- 1 LEDs
- 2 flap with labeling strip
- 3 contact bar
- 4 flap opened with inner label

322-1BH70 - DO 16xDC 24V 0.5A

Pin assignment Circuit diagram Status monitor

Pin	Assignment	Circuit diagram		LED	Description
1	Supply voltage DC 24V (1L+)			1L+, 2L+	LED (green) supply voltage is on
2	Output Q+0.0			.0	LEDs (green) Q+0.0 to Q+1.7
3				.1	
4				.2	
5				.3	
6				.4	
7				.5	
8				.6	
9	Output Q+0.7			.7	As soon as an output is active, the according LED is addressed
10	Ground 1			F	LED (red) Error when overload or short circuits
11	Supply voltage DC 24V (2L+)			2L+	
12	Output Q+1.0			.0	
13				.1	
14				.2	
15				.3	
16				.4	
17				.5	
18				.6	
19	Output Q+1.7			.7	
20	Ground 2			F	

Schematic diagram

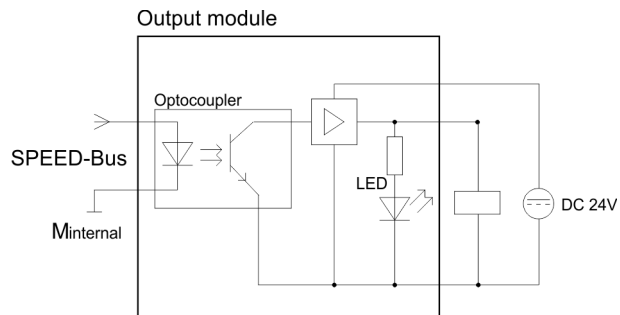

CAUTION!

Please regard that the voltage applied to an output channel must be ≤ the voltage supply applied to L+.

6.4.1 Technical data

Order no.	322-1BH70
Type	SM 322S - SPEED-Bus
SPEED-Bus	✓
Current consumption/power loss	
Current consumption from backplane bus	390 mA
Power loss	5 W
Technical data digital outputs	
Number of outputs	16
Cable length, shielded	1000 m
Cable length, unshielded	600 m
Rated load voltage	DC 24 V
Current consumption from load voltage L+ (without load)	30 mA
Total current per group, horizontal configuration, 40°C	4 A
Total current per group, horizontal configuration, 60°C	4 A
Total current per group, vertical configuration	4 A
Output current at signal "1", rated value	0.5 A
Output delay of "0" to "1"	6.12 µs
Output delay of "1" to "0"	6.12 µs
Minimum load current	-
Lamp load	5 W
Parallel switching of outputs for redundant control of a load	not possible
Parallel switching of outputs for increased power	not possible
Actuation of digital input	✓
Switching frequency with resistive load	max. 100 kHz
Switching frequency with inductive load	max. 0.5 Hz
Switching frequency on lamp load	max. 10 Hz
Internal limitation of inductive shut-off voltage	L+ (-52 V)
Short-circuit protection of output	yes, electronic
Trigger level	1 A
Number of operating cycle of relay outputs	-
Switching capacity of contacts	-
Output data size	2 Byte
Status information, alarms, diagnostics	
Status display	green LED per channel
Interrupts	no
Process alarm	no

323-1BH70 - DIO 16xDC 24V 0.5A

Order no.	322-1BH70
Diagnostic interrupt	no
Diagnostic functions	no
Diagnostics information read-out	none
Supply voltage display	green LED per group
Group error display	red SF LED
Channel error display	none
Isolation	
Between channels	✓
Between channels of groups to	8
Between channels and backplane bus	✓
Insulation tested with	DC 500 V
Datasizes	
Input bytes	0
Output bytes	2
Parameter bytes	0
Diagnostic bytes	0
Housing	
Material	PPE
Mounting	DIN rail SPEED-Bus
Mechanical data	
Dimensions (WxHxD)	40 mm x 125 mm x 120 mm
Weight	250 g
Environmental conditions	
Operating temperature	0 °C to 60 °C
Storage temperature	-25 °C to 70 °C
Certifications	
UL certification	yes

6.5 323-1BH70 - DIO 16xDC 24V 0.5A

Properties

The module has 16 channels that can be used either as inputs or outputs. Every channel supports a diagnostic function, i.e. as soon as an output is active, the according input is set on "1". If there is a short circuit at the load, the according input is set on "0" and the error can be recognized by analyzing the input.

- 16 fast input and output channels, isolated to SPEED-Bus
- Extended parameterization possibility
- Nominal input voltage DC 24V
- Output current 0.5A

- Useable for switches, approximate switches, magnetic valve
- Activity monitoring of the channels via LED

Structure

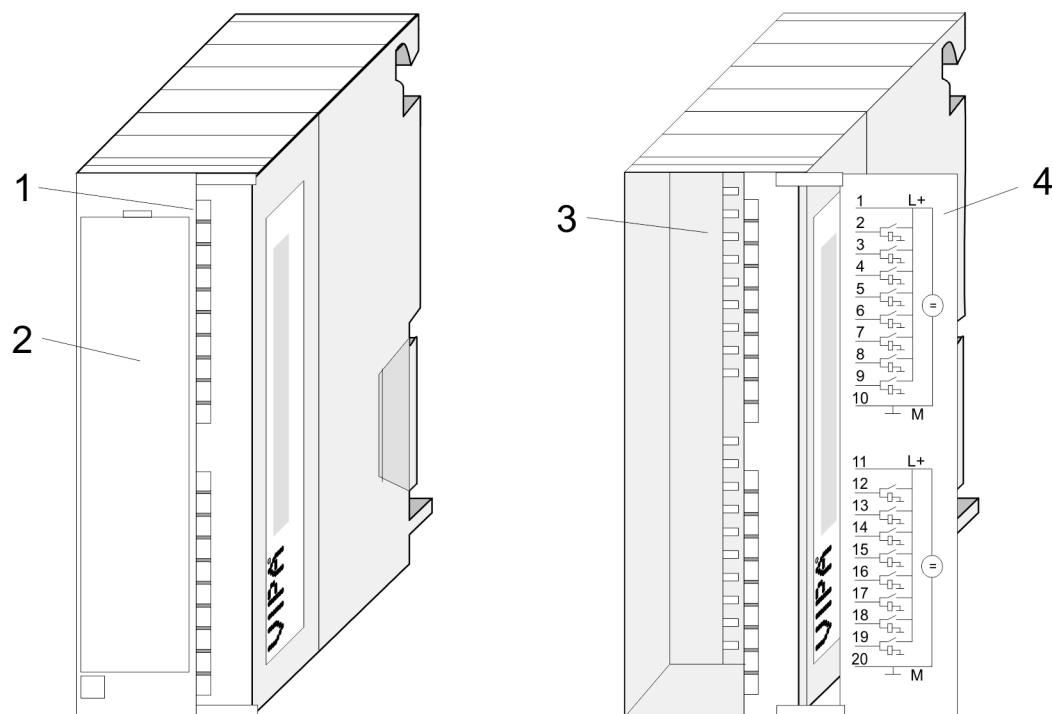

- 1 LEDs
- 2 flap with labeling strip
- 3 contact bar
- 4 flap opened with inner label



CAUTION!

Please regard that the voltage applied to an output channel must be \leq the voltage supply applied to L+. Due to the parallel connection of in- and output channel per group, a set output channel may be supplied via an applied input signal. Thus, a set output remains active even at power-off of the voltage supply with the applied input signal. Non-observance may cause module demolition.

323-1BH70 - DIO 16xDC 24V 0.5A

Pin assignment Circuit diagram Status monitor

Pin	Assignment	Circuit diagram	LED	Description
1	Supply voltage +DC 24V (1L+)		1L+, 2L+	LED (green) supply voltage is on
2	I/Q +0.0			
3	...			
4	I/Q +0.7			
5	...			
6	Ground 1			
7	Supply voltage +DC 24V (2L+)			
8	...			
9	I/Q +1.0			
10	...			
11	Supply voltage +DC 24V (2L+)		.07	LED (green) per byte As soon as an input signal "1" or an active output is recognized, the according LED is addressed
12	I/Q +1.0			
13	...			
14	I/Q +1.7			
15	...			
16	Ground 2			
17	...			
18	...			
19	I/Q +1.7			
20	Ground 2			

Schematic diagram

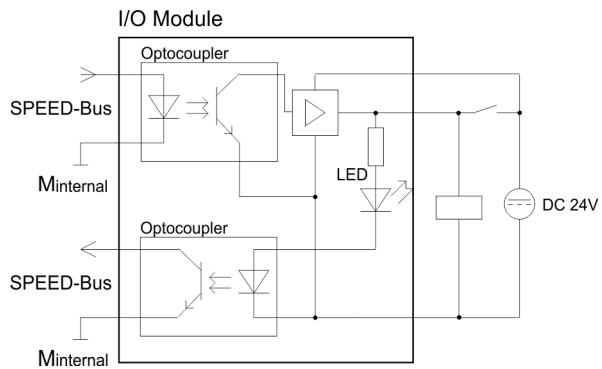

6.5.1 Parameterization

Dependent on project engineering 2byte each in the in and output range respectively 48byte in the input and 2byte in the output range of the CPU where occupied by the module. For project engineering there are the following possibilities:

- Project engineering as *323-1BH70 DIO16xDC24V*
 - Range in PII: 2byte
 - Range in PIQ: 2byte
 - Parameter: none
 - Input filter time delay: 2.56µs
- Project engineering as *DIO16 Alarm/ETS*
 - Range in PII: 48byte
 - Range in PIQ: 2byte
 - Parameter: 66byte (edge selection, time stamp, filter)
 - Input filter time delay: 1µs + param. filter value

6.5.1.1 Project engineering as 323-1BH70 DIO16xDC24V

At this project engineering you have no parameterization options and your module occupies each 2byte in the input and output address range of the CPU. If no hardware project engineering is present, this operation mode is used as default. Here the module has for the inputs a delay time of 2.56µs.

6.5.1.2 Project engineering as DIO16 Alarm/ETS

If the module is defined as "DIO16 Alarm/ETS" in the hardware configuration, it occupies 48byte of the input range of the CPU and 2byte in the output range and can be parameterized with 66byte of data. The following parameters are at your disposal:

- Diagnostic interrupt (global for all inputs)
- Edge selection (switchable process interrupt per channel)
- Time stamp (activation of a time stamp function per channel)
- Filter value (for grubby input signals per channel)

Structure of the parameter data

During the parameterization, a parameter area of 66byte is transferred in the record sets 7Fh, 80h and 81h. Using the SFCs 55, 56 and 57 you may alter parameters and transfer them to the module during runtime. The record sets have the following structure:

Record set 7Fh Diagnostic interrupt

This record set activates res. de-activates the diagnostic function. A diagnostic interrupt occurs when during a process interrupt execution another process interrupt is initialized for the same event.

The record set has the following structure:

Word	
0	<i>Diagnostic interrupt</i> 0000h = de-activated 0001h = activated
2	<i>reserved</i>

Record set 80h Edge selection (Byte 0 ... 15)

Via this record set you may activate a process interrupt for I+0.0 ... I+1.7 and define for which edge of the input signal a process interrupt is thrown.

The record set has the following structure:

Byte	Bit 7 ... Bit 0
0	<ul style="list-style-type: none"> ■ <i>Bit 1, 0: Edge selection I+0.0</i> <ul style="list-style-type: none"> – 00b = de-activated – 01b = Process interrupt at ascending edge – 10b = Process interrupt at descending edge – 11b = Process interrupt at both edges ■ <i>Bit 7 ... 2: reserved</i>
...	...
15	<ul style="list-style-type: none"> ■ <i>Bit 1, 0: Edge selection I+1.7</i> <ul style="list-style-type: none"> – 00b = de-activated – 01b = Process interrupt at ascending edge – 10b = Process interrupt at descending edge – 11b = Process interrupt both edges ■ <i>Bit 7 ... 2: reserved</i>

Record set 80h ETS Time stamp (Byte 16 ... 31)

Every SPEED-Bus module carries along a timer with a resolution of 1 μ s. The timer starts at boot-up of the CPU. Thus gives you a time base with an accuracy of $\pm 1\mu$ s at the SPEED-Bus. By parameterization of the ETS function (**Edge Timestamp**) for an input, the current time value is entered in the process image of the module at according edge. Thus allows you to compare times of different input channels via your user application.

Via the parameter *Time stamp* you may activate the ETS system and define the edge of the input signal that initiates the process image entry of a time stamp. You have the following options:

- No time stamp
- Time stamp at ascending edge
- Time stamp at descending edge
- Time stamp at both edges

Allocation in the process image ↪ '48bytes in the process image' on page 111



The stored times correspond the point in time when the signal has already passed the input filter of the module. To calculate the real time at the clamp, you have to subtract the delay time of 1 μ s and the parameterized delay time defined under Filter.

Byte	Bit 7 ... Bit 0
16	<ul style="list-style-type: none"> ■ Bit 1, 0: Time stamp channel 0 (I+0.0) <ul style="list-style-type: none"> – 00 = no time stamp – 01 = Time stamp at ascending edge – 10 = Time stamp at descending edge – 11 = Time stamp at both edges
...	...
31	<ul style="list-style-type: none"> ■ Bit 1, 0: Time stamp channel 15 (I+1.7) <ul style="list-style-type: none"> – 00 = no time stamp – 01 = Time stamp at ascending edge – 10 = Time stamp at descending edge – 11 = Time stamp at both edges

Record set 81h Input filter

This record set allows you to preset an input filter in steps of 2.56µs steps for I+0.0 ... I+1.7. By preceding a filter you define how long an input signal must be present before it is recognized as "1" signal. With the help of filters you may e.g. filter signal peaks at a blurred input signal.

The entry happens as a factor of 2.56µs (2.56µs ... 40ms) and is within the range 1 ... 16000.

The record set has the following structure:

Word	
0	Input filter I+0.0 in 2.56µs steps
...	...
30	Input filter I+1.7 in 2.56µs steps

48bytes in the process image

The module occupies 48byte in the input address range and 2byte in the output address range of the CPU that have the following meaning:

Input address range

Byte 0 ... 40

Byte	Bit 7 ... Bit 0
0	State of the channels (1 = set, 0 = not set) <ul style="list-style-type: none"> ■ Bit 0: Status I+0.0 ■ ... ■ Bit 7: Status I+0.7
1	State of the channels (1 = set, 0 = not set) <ul style="list-style-type: none"> ■ Bit 8: Status I+1.0 ■ ... ■ Bit 15: Status I+1.7
2 ... 3	reserved

Byte	Bit 7 ... Bit 0			
4	<p>1. edge evaluation (1 = edge detected, 0 = no edge detected)</p> <p>Here the last presence of an edge since the last read access to the register is stored.</p> <p>After a read access to this register (in the module) it is set back.</p> <ul style="list-style-type: none"> ■ Bit 0: Status I+0.0 ■ ... ■ Bit 7: Status I+0.7 			
5	<p>Edge evaluation</p> <ul style="list-style-type: none"> ■ Bit 0: Status I+1.0 ■ ... ■ Bit 7: Status I+1.7 			
6 ... 7	reserved			
8	<p>Edge lost (1 = edge lost, 0 = no edge lost)</p> <p>Here is noted if an edge change has been lost, i.e. if there has been more than one edge change since the last read access.</p> <ul style="list-style-type: none"> ■ Bit 0: Status I+0.0 ■ ... ■ Bit 7: Status I+0.7 			
9	<p>Edge lost</p> <ul style="list-style-type: none"> ■ Bit 0: Status I+1.0 ■ ... ■ Bit 7: Status I+1.7 			
10 ... 11	reserved			
	The following bytes contain the values of the μ s ticker for a channel at the time of an edge change. Only the lower 16bit are taken over. An overflow after 65ms has to be accordingly processed in the user application.			
Byte	+3	+2	+1	+0
12	Time stamp I+0.1		Time stamp I+0.0	
16	Time stamp I+0.3		Time stamp I+0.2	
20	Time stamp I+0.5		Time stamp I+0.4	
24	Time stamp I+0.7		Time stamp I+0.6	
28	Time stamp I+1.1		Time stamp I+1.0	
32	Time stamp I+1.3		Time stamp I+1.2	
36	Time stamp I+1.5		Time stamp I+1.4	
40	Time stamp I+1.7		Time stamp I+1.6	

Byte 44 ... 47

Byte	Bit 7 ... Bit 0
44	2. edge evaluation (1 = edge detected, 0 = no edge detected). Here the last presence of an edge since the last read access to the <i>FA1</i> register is stored. After a read access to this register (in the module) the register is not reset. <ul style="list-style-type: none"> ■ Bit 0: Status I+0.0 ■ ... ■ Bit 7: Status I+0.7
45	Edge evaluation <ul style="list-style-type: none"> ■ Bit 0: Status I+1.0 ■ ... ■ Bit 7: Status I+0.7
46...47	reserved

For guarantee of consistency of a μ s ticker entry to the 1. *edge evaluation* (*FA1*) the 2. *edge evaluation* (*FA2*) serves for. The consistency is ensured only if the appropriate bit of the *FA2* is "0". Since the last read access if more than one edge change took place, the corresponding bit of *edge lost* (*FV*) is set. Here the μ s ticker entry contains the time of the last edge.

Example:

	Byte	+1	+0
FA1	4	0 1 1 0 0 0 1 0	0 1 0 1 1 1 1 0
FV	8	0 0 0 0 0 0 0 0	0 0 0 0 1 0 1 0
...			
FA2	44	0 0 1 1 0 0 0 0	0 0 0 0 1 0 0 1

The consistent μ s ticker entries can be determined by logical bit operations: *FA1* AND NOT *FA2*

Result	0 1 0 0 0 0 1 0 0 1 0 0 0 1 0 0
bit operation:	

Output address range

Byte	Bit 7 ... Bit 0
0	Control output channel (1 = set, 0 = set back) <ul style="list-style-type: none"> ■ Bit 0: Status Q+0.0 ■ ... ■ Bit 7: Status Q+0.7
1	Control output channel (1 = set, 0 = set back) <ul style="list-style-type: none"> ■ Bit 0: Status Q+1.0 ■ ... ■ Bit 7: Status Q+1.7



Depending to the system, the SFC 14 (DPRD_DAT) "Read consistent data" cannot be used with this module.

6.5.2 Process interrupt

Via the edge selection you may activate a process interrupt in your parameterization and define on which edge of the input signal a process interrupt should be initialized. A process interrupt causes a call of the OB 40. Within the OB 40 you may find the logical basic address of the module that initialized the process interrupt by using the *Local word 6*. More detailed information about the initializing event is to find in the *local double word 8*.

Local double word 8 of the OB 40

The *local double word 8* of the OB 40 has the following structure:

Lokalbyte	Bit 7 ... Bit 0
8	<ul style="list-style-type: none"> ■ Bit 0: Edge at I+0.0 ■ ... ■ Bit 7: Edge at I+0.7
9	<ul style="list-style-type: none"> ■ Bit 0: Edge at I+1.0 ■ ... ■ Bit 7: Edge at I+1.7
10	00h (fix)
11	00h (fix)

6.5.3 Diagnostic interrupt

Via the parameterization (record set 7Fh) you may activate a global diagnostic interrupt for the module. A diagnostic interrupt occurs when during a process interrupt execution in OB 40 another process interrupt is thrown for the same event. The initialization of a diagnostic interrupt interrupts the recent process interrupt execution in OB 40 and branches in OB 82 to diagnostic interrupt processing_{incoming}. If during the diagnostic interrupt processing other events are occurring at other channels that may also cause a process res. diagnostic interrupt, these are interim stored. After the end of the diagnostic interrupt processing at first all interim stored diagnostic interrupts are processed in the sequence of their occurrence and then all process interrupts. If a channel where currently a diagnostic interrupt_{incoming} is processed res. interim stored initializes further process interrupts, these get lost. When a process interrupt for which a diagnostic interrupt_{incoming} has been released is ready, the diagnostic interrupt processing is called again as diagnostic interrupt_{outgoing}. All events of a channel between diagnostic interrupt_{incoming} and diagnostic interrupt_{outgoing} are not stored and get lost. Within this time window (1. diagnostic interrupt_{incoming} until last diagnostic interrupt_{outgoing}) the SF-LED of the CPU is on. Additionally for every diagnostic interrupt_{incoming/outgoing} an entry in the diagnostic buffer of the CPU occurs.

Example

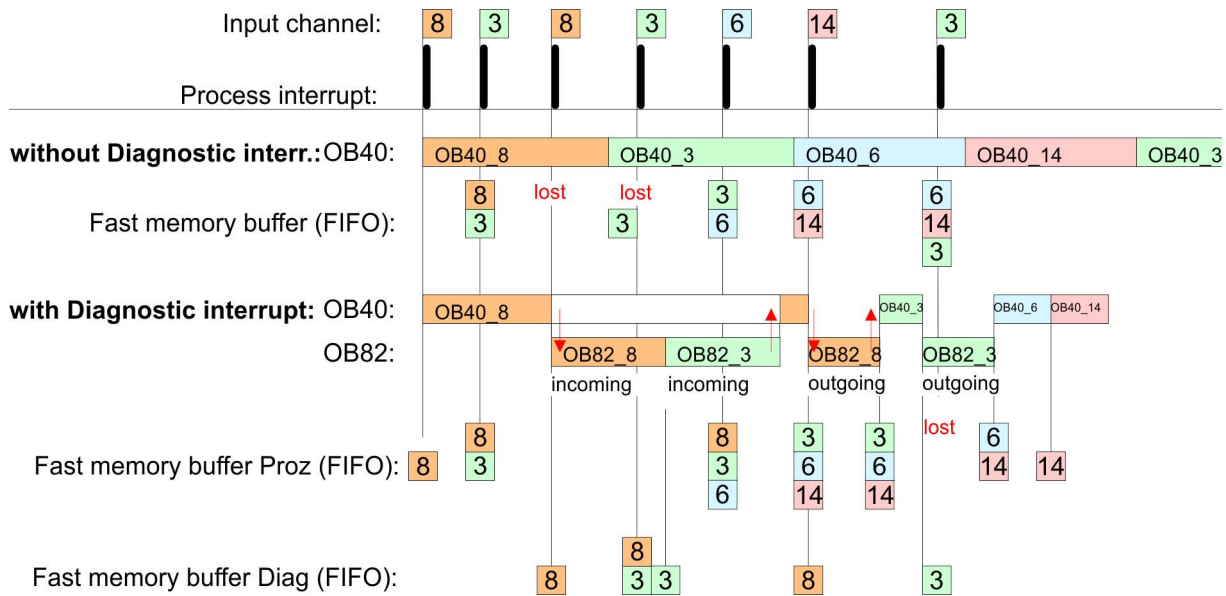

Diagnostic interrupt processing

Every OB 82 call causes an entry in the diagnostic buffer of the CPU containing error cause and module address. By using the SFC 59 you may read the diagnostic bytes. At de-activated diagnostic interrupt you have access to the last recent diagnostic event. If you've activated the diagnostic function in your hardware configuration, the contents of record set 0 are already in the local double word 8 when calling the OB 82. The SFC 59 allows you to also read the record set 1 that contains additional information. After leaving the OB 82 a clear assignment of the data to the last diagnostic interrupt is not longer possible. The record sets of the diagnostic range have the following structure:

Record set 0 Diagnostic_{incoming}

Byte	Bit 7 ... Bit 0
0	<ul style="list-style-type: none"> ■ set at module failure ■ Bit 1: 0 (fix) ■ Bit 2: set at external error ■ Bit 3: set at channel error ■ Bit 4: set when external auxiliary supply is missing ■ Bit 7 ... 5: 0 (fix)
1	<ul style="list-style-type: none"> ■ Bit 3 ... 0: Module class <ul style="list-style-type: none"> - 1111b: Digital ■ Channel information present ■ Bit 7 ... 5: 0 (fix)
2	00h (fix)
3	<ul style="list-style-type: none"> ■ Bit 5 ... 0: 0 (fix) ■ Bit 6: Process interrupt lost ■ Bit 7: 0 (fix)

Record set 0 Diagnostic_{outgoing}

After the removing error a diagnostic message_{outgoing} takes place if the diagnostic interrupt release is still active.

Byte	Bit 7 ... Bit 0
0	<ul style="list-style-type: none"> ■ Bit 0: set at module failure ■ Bit 1: 0 (fix) ■ Bit 2: set at external error ■ Bit 3: set at channel error ■ Bit 4: set when external auxiliary supply is missing ■ Bit 7 ... 5: 0 (fix)
1	<ul style="list-style-type: none"> ■ Bit 3 ... 0: Module class <ul style="list-style-type: none"> – 1111b: Digital ■ Bit 4: Channel information present ■ Bit 7 ... 5: 0 (fix)
2	00h (fix)
3	00h (fix)

Diagnostic Record set 1

The record set 1 contains the 4byte of the record set 0 and additionally 12byte module specific diagnostic data. The diagnostic bytes have the following assignment:

Byte	Bit 7 ... Bit 0
0 ... 3	Contents record set 0 ↪ <i>'Record set 0 Diagnostic_{incoming}' on page 115</i>
4	<ul style="list-style-type: none"> ■ Bit 6 ... 0: channel type <ul style="list-style-type: none"> – 70h: Digital input ■ Bit 7: More channel types present <ul style="list-style-type: none"> ■ 0: no ■ 1: yes
5	Number of diagnostic bits the module puts out per channel (here 08h)
6	Number of channels of a module (here 04h)
7	<ul style="list-style-type: none"> ■ Bit 0: Error in channel group 0 (I+0.0 ... I+0.3) ■ Bit 1: Error in channel group 1 (I+0.4 ... I+0.7) ■ Bit 2: Error in channel group 2 (I+1.0 ... I+1.3) ■ Bit 3: Error in channel group 3 (I+1.4 ... I+1.7) ■ Bit 7 ... 4: 0 (fix)
8	Diagnostic interrupt due to "process interrupt lost" at... <ul style="list-style-type: none"> ■ Bit 0: ... input I+0.0 ■ Bit 1: 0 (fix) ■ Bit 2: ... input I+0.1 ■ Bit 3: 0 (fix) ■ Bit 4: ... input I+0.2 ■ Bit 5: 0 (fix) ■ Bit 6: ... input I+0.3 ■ Bit 7: 0 (fix)

Byte	Bit 7 ... Bit 0
9	Diagnostic interrupt due to "process interrupt lost" at... <ul style="list-style-type: none"> ■ Bit 0: ... input I+0.4 ■ Bit 1: 0 (fix) ■ Bit 2: ... input I+0.5 ■ Bit 3: 0 (fix) ■ Bit 4: ... input I+0.6 ■ Bit 5: 0 (fix) ■ Bit 6: ... input I+0.7 ■ Bit 7: 0 (fix)
10	Diagnostic interrupt due to "process interrupt lost" at... <ul style="list-style-type: none"> ■ Bit 0: ... input I+1.0 ■ Bit 1: 0 (fix) ■ Bit 2: ... input I+1.1 ■ Bit 3: 0 (fix) ■ Bit 4: ... input I+1.2 ■ Bit 5: 0 (fix) ■ Bit 6: ... input I+1.3 ■ Bit 7: 0 (fix)
11	Diagnostic interrupt due to "process interrupt lost" at... <ul style="list-style-type: none"> ■ Bit 0: ... input I+1.4 ■ Bit 1: 0 (fix) ■ Bit 2: ... input I+1.5 ■ Bit 3: 0 (fix) ■ Bit 4: ... input I+1.6 ■ Bit 5: 0 (fix) ■ Bit 6: ... input I+1.7 ■ Bit 7: 0 (fix)
12 ... 15	00h (fix)

6.5.4 Technical data

Order no.	323-1BH70
Type	SM 323S - SPEED-Bus
SPEED-Bus	✓
Current consumption/power loss	
Current consumption from backplane bus	390 mA
Power loss	5 W
Technical data digital inputs	
Number of inputs	16
Cable length, shielded	1000 m
Cable length, unshielded	600 m
Rated load voltage	DC 24 V
Current consumption from load voltage L+ (without load)	-

323-1BH70 - DIO 16xDC 24V 0.5A > Technical data

Order no.	323-1BH70
Rated value	DC 20.4...28.8 V
Input voltage for signal "0"	DC 0...5 V
Input voltage for signal "1"	DC 15...28.8 V
Input voltage hysteresis	-
Frequency range	-
Input resistance	-
Input current for signal "1"	7 mA
Connection of Two-Wire-BEROs possible	✓
Max. permissible BERO quiescent current	1.5 mA
Input delay of "0" to "1"	parameterizable 2.56µs - 40ms
Input delay of "1" to "0"	parameterizable 2.56µs - 40ms
Number of simultaneously utilizable inputs horizontal configuration	16
Number of simultaneously utilizable inputs vertical configuration	16
Input characteristic curve	IEC 61131-2, type 1
Initial data size	2 Byte
Technical data digital outputs	
Number of outputs	16
Cable length, shielded	1000 m
Cable length, unshielded	600 m
Rated load voltage	DC 24 V
Reverse polarity protection of rated load voltage	✓
Current consumption from load voltage L+ (without load)	50 mA
Output current at signal "1", rated value	0.5 A
Output delay of "0" to "1"	6.12 µs
Output delay of "1" to "0"	6.12 µs
Minimum load current	-
Lamp load	5 W
Parallel switching of outputs for redundant control of a load	not possible
Parallel switching of outputs for increased power	not possible
Actuation of digital input	✓
Switching frequency with resistive load	max. 100 kHz
Switching frequency with inductive load	max. 0.5 Hz
Switching frequency on lamp load	max. 10 Hz
Internal limitation of inductive shut-off voltage	L+ (-52 V)
Short-circuit protection of output	yes, electronic

Order no.	323-1BH70
Trigger level	1 A
Number of operating cycle of relay outputs	-
Switching capacity of contacts	-
Output data size	2 Byte
Status information, alarms, diagnostics	
Status display	green LED per channel
Interrupts	no
Process alarm	no
Diagnostic interrupt	no
Diagnostic functions	no
Diagnostics information read-out	none
Supply voltage display	green LED per group
Group error display	red SF LED
Channel error display	none
Isolation	
Between channels	✓
Between channels of groups to	8
Between channels and backplane bus	✓
Insulation tested with	DC 500 V
Datasizes	
Input bytes	2 / 48
Output bytes	2
Parameter bytes	0 / 66
Diagnostic bytes	16
Housing	
Material	PPE
Mounting	DIN rail SPEED-Bus
Mechanical data	
Dimensions (WxHxD)	40 mm x 125 mm x 120 mm
Weight	200 g
Environmental conditions	
Operating temperature	0 °C to 60 °C
Storage temperature	-25 °C to 70 °C
Certifications	

323-1BH70 - DIO 16xDC 24V 0.5A > Technical data

Order no.	323-1BH70
UL certification	yes
KC certification	-