

SGM7J

Model Designations

SGM7J

Sigma-7 Series
Servomotors:
SGM7J

- 02 D F F 6 1
1st + 2nd 3rd 4th 5th 6th 7th digit

1st + 2nd digit - Rated Output	
Code	Specification
02	200 W
04	400 W
08	750 W
15	1.5 kW

3rd digit - Power Supply Voltage	
Code	Specification
D	400 VAC

4th digit - Serial Encoder	
Code	Specification
7	24-bit absolute
F	24-bit incremental

5th digit - Design Revision Order	
Code	Specification
F	Standard Model

6th digit - Shaft End	
Code	Specification
2	Straight without key
6	Straight with key and tap

7th digit - Options	
Code	Specification
1	Without options
C	With holding brake (24 VDC)

Bolded options are considered standard warehouse products.

Specifications and Ratings

Specifications

Voltage		400 V			
Model SGM7J-		02D	04D	08D	15D
Time Rating		Continuous			
Thermal Class		B			
Insulation Resistance		500 VDC, 10 MOhm min.			
Withstand Voltage		1,800 VAC for 1 minute			
Excitation		Permanent magnet			
Mounting		Flange-mounted			
Drive Method		Direct drive			
Rotation Direction		Counterclockwise (CCW) for forward reference when viewed from the load side			
Vibration Class*1		V15			
Environmental Conditions	Surrounding Air Temperature	0 °C to 40 °C (With derating, usage is possible between 40 °C and 60 °C)*4			
	Surrounding Air Humidity	20% to 80% relative humidity (with no condensation)			
	Installation Site	<ul style="list-style-type: none"> • Must be indoors and free of corrosive and explosive gases. • Must be well-ventilated and free of dust and moisture. • Must facilitate inspection and cleaning. • Must have an altitude of 1,000 m or less. (With derating, usage is possible between 1,000 m and 2,000 m.)*5 • Must be free of strong magnetic fields. 			
	Storage Environment	Store the Servomotor in the following environment if you store it with the power cable disconnected. Storage Temperature: -20 °C to 60 °C (with no freezing) Storage Humidity: 20% to 80% relative humidity (with no condensation)			
Shock Resistance*2	Impact Acceleration Rate at Flange	490 m/s ²			
	Number of Impacts	2 times			
Vibration Resistance*3	Vibration Acceleration Rate at Flange	49 m/s ²			
Applicable SERVOPACKS	SGD7S-	1R9D		3R5D	5R4D

*1. A Vibration class of V15 indicates a vibration amplitude of 15 µm maximum on the Servomotor without a load at the rated motor speed.

*2. The shock resistance for shock in the vertical direction when the Servomotor is mounted with the shaft in a horizontal position is given in the above table.

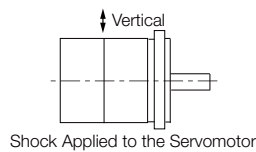

*3. The vertical, side-to-side, and front-to-back vibration resistance for vibration in three directions when the Servomotor is mounted with the shaft in a horizontal position is given in the above table. The strength of the vibration that the Servomotor can withstand depends on the application. Always check the vibration acceleration rate that is applied to the Servomotor with the actual equipment.

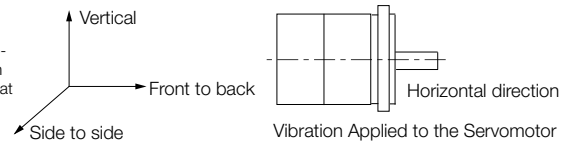

*4. If the surrounding air temperature will exceed 40°C, refer to the section "Applications where the Surrounding Air Temperature of the Servomotor Exceeds 40°C".

*5. If the altitude will exceed 1,000 m, refer to the section "Applications where the Altitude of the Servomotor Exceeds 1000m".

Rotary Servomotors SGM7J

Ratings

Voltage		400 V				
Model SGM7J-		02D	04D	08D	15D	
Rated Output *1	W	200	400	750	1500	
Rated Torque *1, *2	Nm	0.637	1.27	2.39	4.77	
Instantaneous Maximum Torque *1	Nm	2.23	4.46	8.36	14.3	
Rated Current *1	Arms	1.5	1.4	2.2	4.5	
Instantaneous Maximum Current *1	Arms	5.5	5.3	8.2	14.0	
Rated Motor Speed *1	min ⁻¹	3000				
Maximum Motor Speed	min ⁻¹	6000				
Torque Constant	Nm/Arms	0.461	0.965	1.17	1.13	
Motor Moment of Inertia	×10 ⁻⁴ kg m ²	0.263 (0.333)	0.486 (0.556)	1.59 (1.77)	4.02 (4.90)	
Rated Power Rate *1	kW/s	15.4 (12.1)	33.1 (29.0)	35.9 (32.2)	56.6 (46.6)	
Rated Angular Acceleration Rate *1	rad/s ²	24200 (19100)	26100 (22800)	15000 (13500)	11900 (9700)	
Heat Sink Size (aluminium)	mm	250 × 250 × 6			300 × 300 × 12	
Protective Structure *3		Totally enclosed, self-cooled, IP67				
Holding Brake Specifications *4	Rated Voltage	V	24 VDC ± 10%			
	Capacity	W	6	6.5	7.5	
	Holding Torque	Nm	0.637	1.27	2.39	4.77
	Coil Resistance	Ω (at 20 °C)	96 ± 10%		88.6 ± 10%	76.8 ± 10%
	Rated Current	A (at 20 °C)	0.25		0.27	0.31
	Time Required to Release Brake	ms	60		80	
	Time Required to Brake	ms	100			
Allowable Load Moment of Inertia (Motor Moment of Inertia Ratio)	Standard	15 times	10 times	12 times	6 times	
	With External Regenerative Resistor or Dynamic Brake Resistor Connected	25 times		15 times	12 times	
Allowable Shaft Load *5	LF	mm	25		35	
	Allowable Radial Load	N	245		392	490
	Allowable Thrust Load	N	74		147	

Note: The values in parentheses are for Servomotors with holding brakes.

- These values are for operation in combination with a SERVOPACK when the temperature of the armature winding is 100°C. The values for other items are at 20°C. These are typical values.
- The rated torques are the continuous allowable torque values at a surrounding air temperature of 40°C with an aluminium heat sink of the dimensions given in the table.
- This does not apply to the shaft opening. Protective structure specifications apply only when the special cable is used.
- Observe the following precautions if you use a Servomotor with a holding brake.
 - The holding brake cannot be used to stop the Servomotor.
 - The time required to release the brake and the time required to brake depend on which discharge circuit is used. Confirm that the operation delay time is appropriate for the actual equipment.
 - The 24-VDC power supply is not provided by YASKAWA.
- The allowable shaft loads are illustrated in the following figure. Design the mechanical system so that the thrust and radial loads applied to the Servomotor shaft end during operation do not exceed the values given in the table.

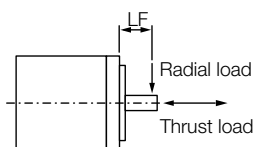

Motor Speed-Torque Characteristics

A : Continuous duty zone

B : Intermittent duty zone

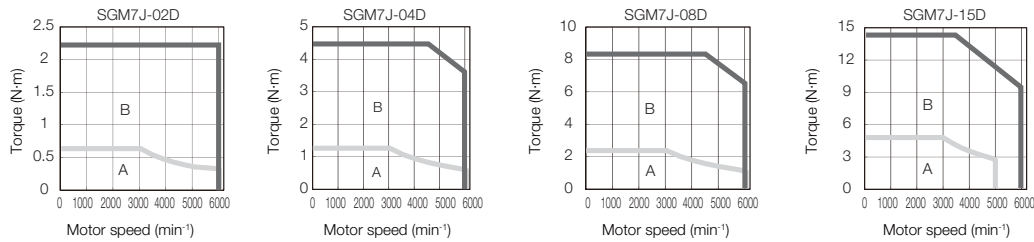

Notes:

- These values are for operation in combination with a SERVOPACK when the temperature of the armature winding is 100°C. These are typical values.
- The characteristics in the intermittent duty zone depend on the power supply voltage. The intermittent duty zones in the graphs show the characteristics when a three-phase, 400-VAC power supply voltage is used.
- If the effective torque is within the allowable range for the rated torque, the Servomotor can be used within the intermittent duty zone.
- If you use a Servomotor Main Circuit Cable that exceeds 20 m, the intermittent duty zone in the torque-motor speed characteristics will become smaller because the voltage drop increases.

Servomotor Overload Protection Characteristics

The overload detection level is set for hot start conditions with a Servomotor surrounding air temperature of 40°C.

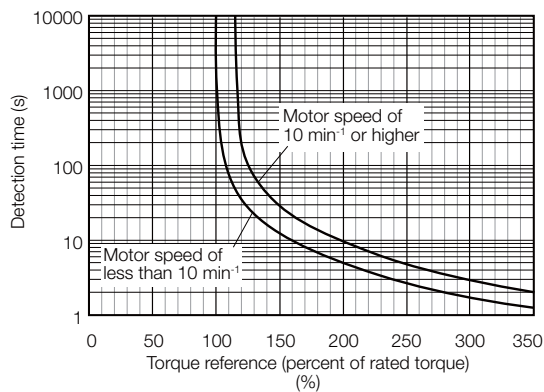

Note:

The above overload protection characteristics do not mean that you can perform continuous duty operation with an output of 100% or higher.

Use the Servomotor so that the effective torque remains within the continuous duty zone given in Motor Speed-Torque Characteristics above.

Load Moment of Inertia

The load moment of inertia indicates the inertia of the load. The larger the load moment of inertia, the worse the response. If the moment of inertia is too large, operation will become unstable.

The allowable size of the load moment of inertia (J_L) for the Servomotor is restricted. Refer to Ratings of Rotary Servomotors SGM7J. This value is provided strictly as a guideline and results depend on Servomotor driving conditions.

An Overvoltage Alarm (A.400) is likely to occur during deceleration if the load moment of inertia exceeds the allowable load moment of inertia. SERVOPACKs with a built-in regenerative resistor may generate a Regenerative Overload Alarm (A.320). Perform one of the following steps if this occurs.

- Reduce the torque limit.
- Reduce the deceleration rate.
- Reduce the maximum motor speed.
- Install an external regenerative resistor if the alarm cannot be cleared using the above steps.

Servomotor Heat Dissipation Conditions

The Servomotor ratings are the continuous allowable values at a surrounding air temperature of 40°C when a heat sink is installed on the Servomotor. If the Servomotor is mounted on a small device component, the Servomotor temperature may rise considerably because the surface for

heat dissipation becomes smaller. Refer to the following graphs for the relation between the heat sink size and derating rate.

Also, change the overload warning and overload alarm detection timing in advance based on the overload detection

level of the motor. Refer to the Servomotor Overload Protection Characteristics.

Note:

The derating rates are applicable only when the average motor speed is less than or equal to the rated motor speed. If the average motor speed exceeds the rated motor speed, consult with your YASKAWA representative.

Important:

The actual temperature rise depends on how the heat sink (i.e., the Servomotor mounting section) is attached to the installation surface, what material is used for the Servomotor mounting section, and the motor speed. Always check the Servomotor temperature with the actual equipment.

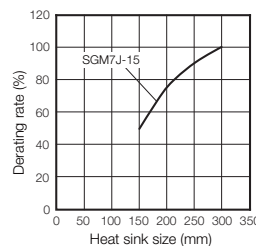
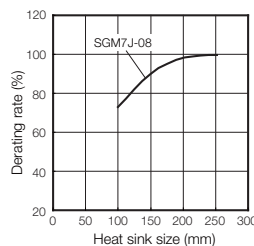
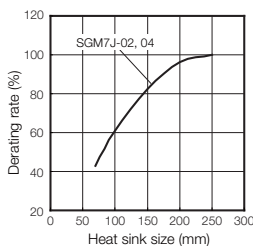

See Servomotor Ratings for more information.

Applications Where the Surrounding Air Temperature of the Servomotor Exceeds 40°C

The Servomotor ratings are the continuous allowable values at a surrounding air temperature of 40°C. If you use a Servomotor at a surrounding air temperature that exceeds 40°C (60°C max.), apply a suitable derating rate from the following graphs.

Also, change the overload warning and overload alarm detection timing in advance based on the overload detection level of the motor. Refer to the Servomotor Overload Protection Characteristics.

Note:

1. Use the combination of the SERVOPACK and Servomotor so that the derating conditions are satisfied for both the SERVOPACK and Servomotor.
2. The derating rates are applicable only when the average motor speed is less than or equal to the rated motor speed. If the average motor speed exceeds the rated motor speed, consult with your YASKAWA representative.

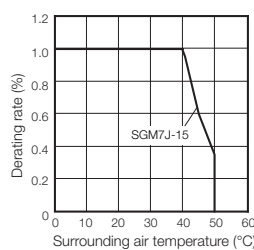
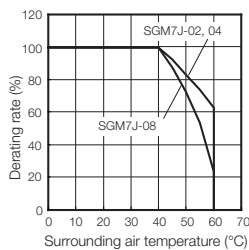

Applications Where the Altitude of the Servomotor Exceeds 1,000 m

The Servomotor ratings are the continuous allowable values at an altitude of 1,000 m or less. If you use a Servomotor at an altitude that exceeds 1,000 m (2,000 m max.), the heat dissipation effect of the air is reduced. Apply the appropriate derating rate from the following graphs.

Also, change the overload warning and overload alarm detection timing in advance based on the overload detection level of the motor. Refer to the Servomotor Overload Protection Characteristics.

Note:

1. Use the combination of the SERVOPACK and Servomotor so that the derating conditions are satisfied for both the SERVOPACK and Servomotor.
2. The derating rates are applicable only when the average motor speed is less than or equal to the rated motor speed. If the average motor speed exceeds the rated motor speed, consult with your YASKAWA representative.

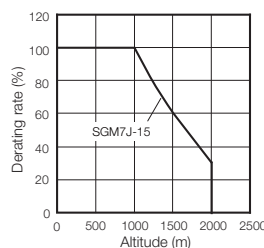
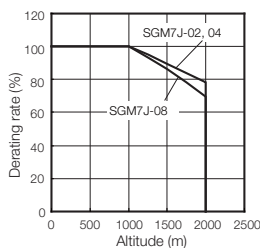

Rotary Servomotors SGM7J

External Dimensions

SGM7J-02 and -04

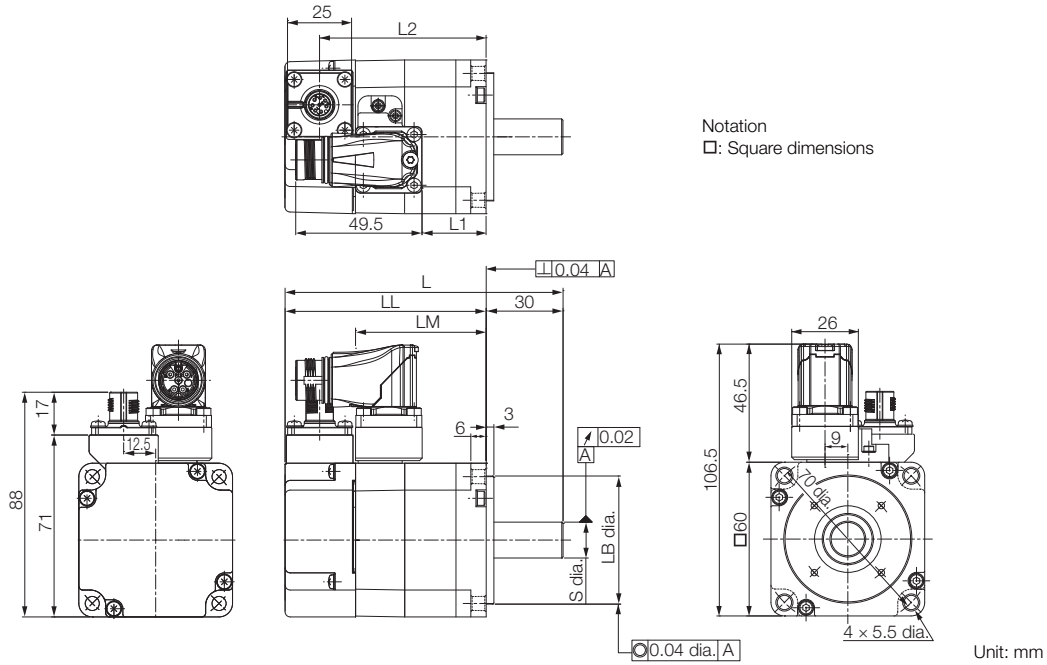

Model SGM7J-	L	LL	LM	LB	S	L1	L2	Approx. Mass [kg]
02D□F2□	108.5 (148.5)	78.5 (118.5)	51.2	50 ⁰ -0.025	14 ⁰ -0.011	25	65 (105)	0.9 (1.5)
04D□F2□	125 (165)	95 (135)	67.2	50 ⁰ -0.025	14 ⁰ -0.011	41.5	81.5 (121.5)	1.2 (1.8)

Note:

1. The values in parentheses are for Servomotors with Holding Brakes.
2. Refer to the section Shaft End Specification.
3. Refer to the section Connectors Specification.

SGM7J-08

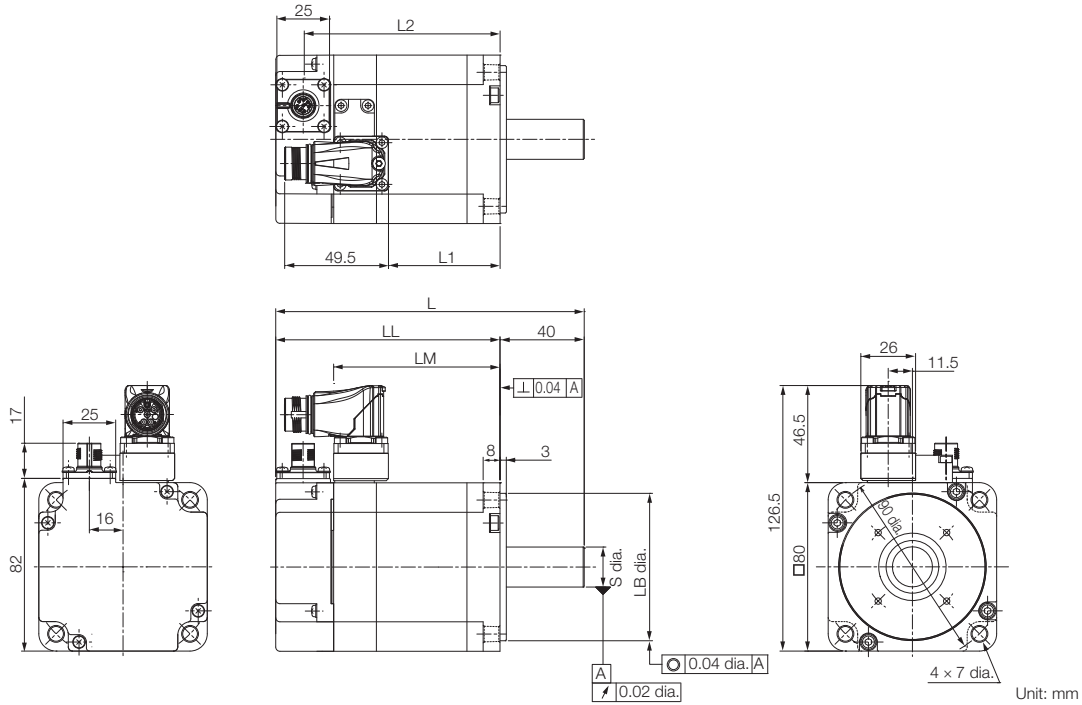

Model SGM7J-	L	LL	LM	LB	S	L1	L2	Approx. Mass [kg]
08D□F□□	146.5 (193.5)	106.5 (153.5)	79	70 ⁰ _{-0.030}	19 ⁰ _{-0.013}	53	93 (121.5)	2.3 (2.9)

Note:

1. The values in parentheses are for Servomotors with Holding Brakes.
2. Refer to the section Shaft End Specification.
3. Refer to the section Connectors Specification.

Rotary Servomotors SGM7J

SGM7J-15

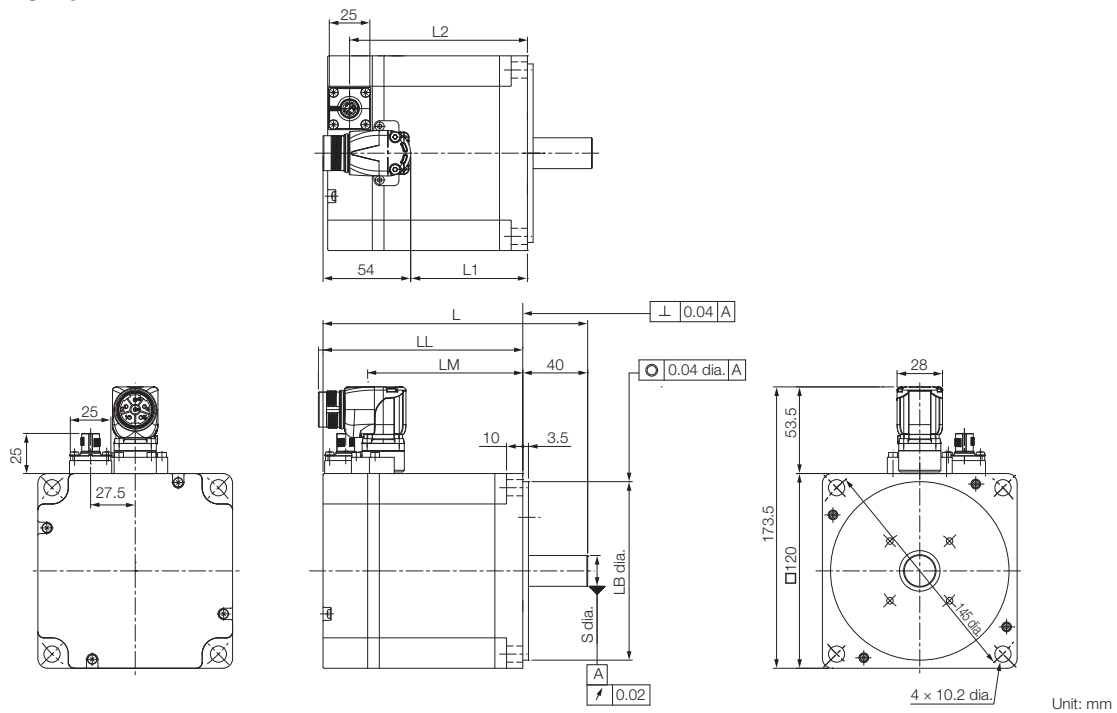

Unit: mm

Model SGM7J-	L	LL	LM	LB	S	L1	L2	Approx. Mass [kg]
15D□F2□	163.5 (196.5)	123.5 (156.5)	95.6	110 ⁰ _{-0.035}	19 ⁰ _{-0.013}	72	110 (143)	6.4 (8.1)

Note:

1. The values in parentheses are for Servomotors with Holding Brakes.
2. Refer to the section Shaft End Specification.
3. Refer to the section Connectors Specification SGM7J-15D.

Shaft End Specifications

SGM7J-□□□□□□□□

Code	Specification
2	Straight without key
6	Straight with key and tap for one location (Key slot is JIS B1301-1996 fastening type.)

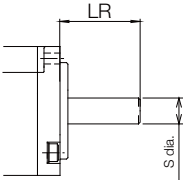
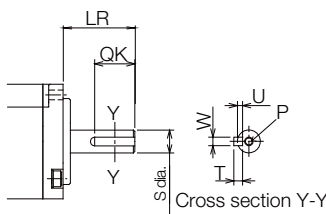
Shaft End Details	Servomotor Model SGM7J-			
	02	04	08	15
Code: 2 (Straight without Key)				
	LR	30	40	
	S	14 ⁰ _{-0.011}	19 ⁰ _{-0.013}	
Code: 6 (Straight with Key and Tap)				
	LR	30	40	
	QK	14	22	
	S	14 ⁰ _{-0.011}	19 ⁰ _{-0.013}	
	W	5	6	
	T	5	6	
	U	3	3.5	
	P	M5 × 8L	M6 × 10L	

Rotary Servomotors SGM7J

Connector Specifications

SGM7J-02 to -15

- Encoder Connector Specifications

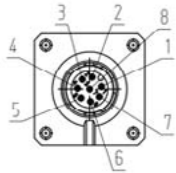

Receptacle
 Size: M12
 Part number: 1419959
 Model: SACC-MSQ-M12MS-25-3,2 SCO
 Manufacturer: Phoenix Contact

1	PG 5V
2	PG 0V
3	FG
4	BAT (+)
5	BAT (-)
6	Data (+)
7	Data (-)
8	Empty
Housing	Shield

SGM7J-02 to -08

- Servomotor Connector Specifications

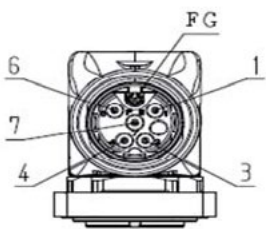

Receptacle
 Size: M17
 Part number: 1620448
 Model: ST-5EP1N8AA500S
 Manufacturer: Phoenix Contact

1	(Brake)
3	U
4	V
5	Empty
6	(Brake)
7	W
FG	FG
Housing	Shield

SGM7J-15

- Servomotor Connector Specifications

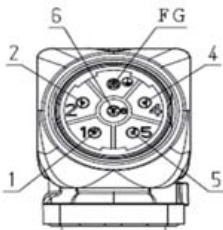

Receptacle
 Size: M23
 Part number: 1617905
 Model: ST-5EP1N8AAD00S
 Manufacturer: Phoenix Contact

1	V
2	(Brake)
4	(Brake)
5	U
6	W
FG	FG
Housing	Shield

Servomotor Connector Rotational Angle

Allowable number of rotations: 10

SGM7G-02 to -15

